

TECHNICAL MANUAL

**ORGANIZATIONAL, DIRECT
SUPPORT AND GENERAL SUPPORT
MAINTENANCE MANUAL**

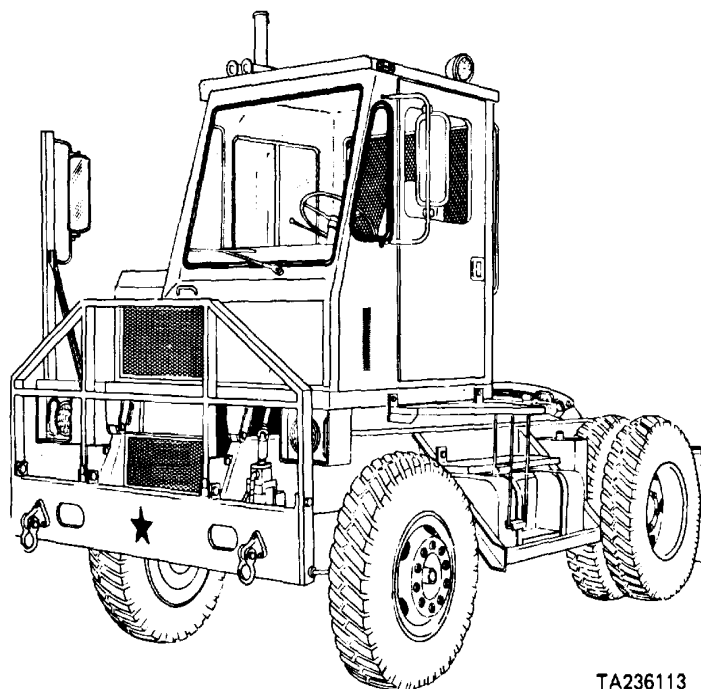

TA236113

**TRUCK TRACTOR, YARD TYPE,
43,500 LB GVW, DED, 4x2,
ARMY MODEL M878A1
(OTTAWA MODEL 50)
(NSN 2320-01-121-2102)**

**HEADQUARTERS, DEPARTMENT OF THE ARMY
OCTOBER 1985**

HOW TO USE THIS MANUAL
PAGE iii

INTRODUCTION
PAGE 1-1

**EQUIPMENT DESCRIPTION
AND DATA**
PAGE 1-3

PRINCIPLES OF OPERATION
PAGE 1-5

**ORGANIZATIONAL
MAINTENANCE
PROCEDURES**
PAGE 2-1

**(ORGANIZATIONAL)
PREVENTIVE MAINTENANCE
CHECKS AND SERVICES
(PMCS)**
PAGE 2-5

TROUBLESHOOTING INDEX
PAGE 2-11

**PREPARATION FOR STORAGE
OR SHIPMENT**
PAGE 2-938

ALPHABETICAL INDEX
INDEX 1

WARNING

Winterization system heaters operate from 110 Vac commercial power source. Disconnect winterization system cable from receptacle at front bumper before removing winterization system heaters. When installing winterization system heaters, be sure you twist together the same color wire ends. Incorrect wire connections, or exposed wire due to frayed insulation, can cause the engine and body of tractor to be energized at 110 Vac. Serious injury or death can result from contact with energized 110 Vac power lines. If you are injured, obtain medical aid immediately.

WARNING

Dry cleaning solvent (P-D-680), used to clean parts is toxic and flammable. Wear protective goggles and gloves and use only in a well ventilated area. Avoid contact with skin, eyes, and clothes and don't breathe vapors. Do not use near open flame or excessive heat and don't smoke when using it. Failure to do so could cause serious injury. If you become dizzy while using cleaning solvent, get fresh air and medical attention immediately. If contact with skin or clothes is made, flush with large amounts of water. If contact with eyes is made, wash eyes with water and obtain medical aid immediately.

WARNING

Battery electrolyte is toxic and corrosive. Wear protective goggles and gloves when removing battery caps and checking electrolyte. Avoid contact with skin, eyes, clothes, and don't breathe vapors. Don't smoke or use an open flame near batteries. Batteries release hydrogen, an explosive gas, during charging. Failure to follow this procedure could cause serious injury or death due to batteries exploding.

WARNING

Allow components to cool before removing. Hot oil, steam, and coolant can cause severe injury. If you are scalded or burned, seek medical aid immediately.

WARNING

Before performing a procedure that requires raising' tractor, be sure that tractor is securely supported by jack stands; if possible, be sure that chain hoist is bearing some of the weight of vehicle as a safety precaution in the event jack stands collapse. Failure to follow this procedure could result in serious injury or death due to tractor falling. If you are injured, seek medical aid immediately.

WARNING

Never crawl under equipment when performing maintenance unless equipment is blocked securely. Keep clear of equipment when it is raised or lowered. Do not place any part of body between movable and fixed elements of the equipment. Don't allow heavy components to swing while suspended by lifting device. Use extreme caution when working near a cable or chain under tension. When using chain hoist to remove or install parts, be sure hoist is securely fastened to the part and that all slack in chain is taken up. Death or severe injury may result if personnel fail to observe these safety precautions. If you are hurt by a falling object or chain or cable under tension, seek medical aid immediately.

WARNING

Be sure chain hoist is securely fastened to heavy tractor components before removing supporting hardware. Do not allow heavy components to fall freely. Failure to follow these precautions could cause serious injury due to parts falling on you. If you are injured by falling equipment, seek medical aid immediately.

WARNING

Battery box lid is heavy. Secure lid in open position to prevent injury from falling lid. If you are injured, obtain medical aid immediately.

WARNING

Stand out from raised cab unless safety bar is supporting full weight of cab. Keep clear of deck when raising or lowering cab. Failure to do so could cause serious injury or death.

WARNING

Personal injury and property damage can result if vehicle is allowed to move during transmission stall test or hydraulic pressure test. Secure tractor frame to an immovable object, chock all wheels, and apply service brakes before you accelerate engine. Do not permit anyone to stand in front of tractor during test.

WARNING

If hydraulic steering system or fuel system connectors or elbows require replacement, discard hose. If hydraulic steering system hose is reused, hydraulic oil leakage could occur causing loss of steering control. This in turn could cause serious injury or loss of life. If fuel system hose is reused, leakage could occur causing a fire hazard.

WARNING

Be sure tire is completely deflated and valve core is removed before dismounting tire. Failure to do so could cause serious injury due to parts flying off wheel and tire. Don't use oil to lubricate tire when mounting. Oil will cause rubber to deteriorate over a period of time with possible personal injury resulting. Place tire and wheel assembly in a safety cage before inflating tire. Don't overinflate tire. If not properly assembled, inflation may cause the wheel and rim to separate with explosive force causing serious injury or death. If you are injured, seek medical help immediately.

WARNING

Use caution when you remove components under pressure from compression spring. Failure to do so could cause serious injury by parts flying up and hitting your eye. If you are injured, obtain medical aid immediately.

WARNING

Brake linings contain asbestos fibers. Do not generate dust when working on brake system. Don't remove dust or dirt with compressed air. Serious bodily harm may result from breathing asbestos dust.

WARNING

Compressed air must not exceed 30 psi. Wear safety glasses when using compressed air. Failure to do so could cause serious injury to eyes and possible blindness. If you hurt your eyes or if a foreign object is blown into your eyes, obtain medical attention immediately.

WARNING

Relieve all pressure from tractor air system before disconnecting air system lines and fittings. Wear safety glasses and stand clear of loosened air line fitting. High pressure air can propel debris at high speed, causing eye injury or blindness. If you are injured, obtain medical aid immediately.

WARNING

When installing air tubing on insert-type fitting, tubing must be installed over insert for secure connection. Installation of fitting without insert will allow air pressure to force tubing from fitting, resulting in dangerous loss of air pressure.

WARNING

Diesel fuel is highly combustible. Do not smoke or allow sparks or open flames near fuel. Death or severe injury may result if you fail to observe this precaution. If you are burned, obtain medical aid immediately.

WARNING

Do not use quick start switch without cranking engine. Overcharge of ether starting fluid can cause explosion of engine air intake system. Ether is highly flammable. Do not puncture ether cylinder or discard in an open fire. Failure to follow this precaution could cause severe injury.

WARNING

Wear protective goggles and heavy gloves when you remove or install glass. Remove and handle broken glass carefully. Failure to do so could cause serious injury due to glass puncturing or cutting your skin or eye. If you are injured by broken glass, obtain medical aid immediately.

WARNING

Wear safety glasses when using hammer or removing rivets. Don't strike hardened steel parts with steel hammer. Failure to do so could cause injury due to metal chips striking your eyes. Obtain medical attention immediately if you get metal chips in your eyes.

WARNING

Be careful not to come in contact with rotating fan, belts, or other moving parts. To do so will cause serious injury. If you are injured, obtain medical aid immediately.

WARNING

Don't bleach or dye tethers or seat belt. To do so may reduce their strength resulting in seat belt or tether breaking under stress, causing serious injury or death if there is an accident involving stress on these parts.

Refer to FM 21-11 for first aid for injured personnel.

TECHNICAL MANUAL
ORGANIZATIONAL, DIRECT
SUPPORT AND GENERAL SUPPORT
MAINTENANCE MANUAL

TRUCK TRACTOR, YARD TYPE
43,500 LB GVW, DED, 4X2,
ARMY MODEL M878A1
(OTTAWA MODEL 50)
NSN 2320-01-121-2102

REPORTING OF ERRORS

You can help improve this manual. If you find any mistakes or if you know of a way to improve the procedures, please let us know. Mail your letter, DA Form 2028 (Recommended Changes to Publications and Blank Forms), or DA Form 2028-2 located in back of this manual direct to: Commander, US Army Tank-Automotive Command, ATTN: DRSTA-MT, Warren, MI 48397-5000. A reply will be furnished to you.

VOLUME 1

		Page
	HOW TO USE THIS MANUAL	iii
CHAPTER 1	INTRODUCTION	1-1
	Chapter Overview	1-1
Section I	General Information	1-1
II	Equipment Description and Data	1-3
III	Principles of Operation	1-5
CHAPTER 2	ORGANIZATIONAL MAINTENANCE PROCEDURES	2-1
	Chapter Overview	2-1
Section I	Service Upon Receipt	2-3
II	Preventive Maintenance Checks and Services (PMCS)	2-5
III	Troubleshooting Symptom Index	2-11
IV	Engine, Fuel, Exhaust, and Cooling Systems Maintenance	2-17
V	Electrical System Maintenance	2-166
VI	Power Train Maintenance	2-419
VII	Brake System Maintenance	2-518
VIII	Wheels and Steering System Maintenance	2-643
IX	Frame and Towing Attachments, Shock Absorbers, and Body and Cab Maintenance	2-672
X	Accessories Maintenance	2-759
XI	Hydraulic Systems Maintenance	2-861
XII	Gages Maintenance	2-906
XIII	Preparation for Storage or Shipment	2-938
	ALPHABETICAL INDEX	Index 1

VOLUME 2

		Page
CHAPTER	3	DIRECT SUPPORT MAINTENANCE PROCEDURES 3-1
		Chapter Overview 3-1
Section	I	Engine and Cooling Systems Maintenance 3-2
	II	Electrical System Maintenance 3-34
	III	Power Train Maintenance 3-89
	IV	Brake System Maintenance 3-153
	V	Steering System Maintenance 3-226
	VI	Frame and Towing Attachments, Springs, and Body and Cab Maintenance 3-294
	VII	Accessories Maintenance 3-399
	VIII	Hydraulic Systems Maintenance 3-407
	IX	Pre-Embarkation Inspection of Material in Units Alerted for Overseas Shipment 3-475
CHAPTER	4	GENERAL SUPPORT MAINTENANCE PROCEDURES 4-1
		Chapter Overview 4-1
Section	I	Engine and Fuel System Maintenance 4-1
	II	Power Train Maintenance 4-2
APPENDIX	A	REFERENCES A-1
	B	MAINTENANCE ALLOCATION CHART B-1
	C	EXPENDABLE SUPPLIES AND MATERIALS LIST C-1
	D	TORQUE LIMITS D-1
	E	ELECTRICAL, HYDRAULIC, AND PNEUMATIC DIAGRAMS E-1
	F	GLOSSARY F-1
	G	ILLUSTRATED LIST OF MANUFACTURED ITEMS G-1
		ALPHABETICAL INDEX Index 1

HOW TO USE THIS MANUAL

This manual is designed to help you maintain the M878A1 tractor. It's divided into volumes, chapters, sections, and appendices. Volume 1 chapters contain general information and organizational maintenance procedures. Volume 2 chapters contain direct support and general support maintenance procedures. The chapters are divided into sections containing maintenance procedures for the various tractor systems.

The appendices contain supplemental information which you require to maintain the M878A1 tractor.

The maintenance procedures contained in this manual tell you several things:

-what tools you need to do the job
-materials or parts required
-what condition the vehicle is to be in before work is started

In addition to text, you'll have either an assembled view or an exploded-view illustration of the associated parts. Sometimes, the illustration will be keyed by an arrow to an overall view of the vehicle to help you determine the approximate location of the parts. The illustration is keyed to the text by numbers and shows you how to take the part off and put it on. The following problem will show you some of the features of this manual.

PROBLEM

An operator brings his M878A1 tractor into the shop with an engine problem: The engine is hard to start. The best way to solve his problem is by using your manual. This is what you do:

1. How do you start?
Look at the cover of this manual.
On the cover you'll find a listing for TROUBLESHOOTING INDEX. It tells you to go to page 2-11. To find page 2-11 fast, open the manual by using the black tab that lines up with the listing on the cover.
2. What kind of problem do you have?
Find it in the symptom index.
The symptom index is a list of problems covered by the section. It tells you that your problem, "engine hard to start or will not start" is covered in paragraph 2-8, Malfunction entry number 1.
3. How do you determine what is causing the problem?
Go to paragraph 2-8, Malfunction entry number 1.
There you'll find the troubleshooting procedures you'll need. The procedure has columns with the headings: MALFUNCTION, TEST OR INSPECTION, and CORRECTIVE ACTION. Starting at step 1, read the procedure. Each step tells you what to do and what to look for. Follow the steps, in order, until you find your problem. When you find the problem, the CORRECTIVE ACTION column will tell you how to fix it.

HOW TO USE THIS MANUAL (CONT)

4. Let's assume you've found that the starter is bad. The replacement procedure is in paragraph 2-25b. The procedure contains all the information you'll need to replace the starter. First check the introductory material. It tells you what you'll need before you start the job. Below the introductory material is an assembled view of the vehicle showing the approximate location of the engine, an assembled view of the engine showing the location of the starter, and an exploded-view illustration which shows you how to take it out and put it back in. The text which follows the illustration tells you how to do the job.
5. If on the other hand, you know what the problem is and its cause, refer to the alphabetical index located at the rear of this manual and find the name of the part to be replaced and the paragraph number in which maintenance procedures will be found. For example, the engine is overheating, on filling the radiator with coolant you see that coolant is pouring out of a radiator hose indicating that the hose requires replacement. Referring to the alphabetical index under the listing "Hoses, Coolant" paragraph 2-15c is referenced. Turn to this paragraph for radiator hose removal and installation procedures.

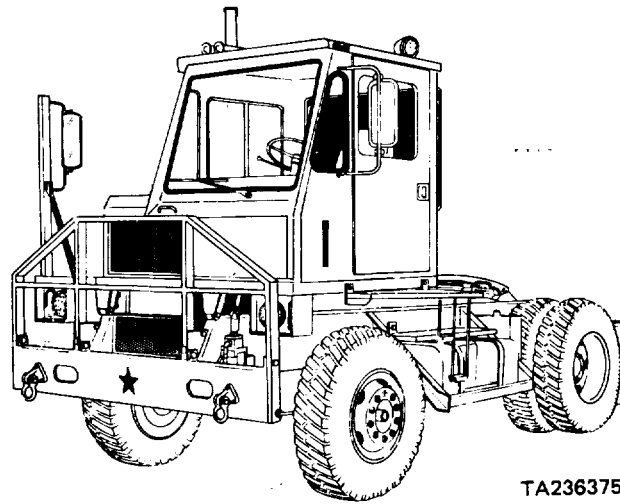

TA236375

LEFT FRONT VIEW

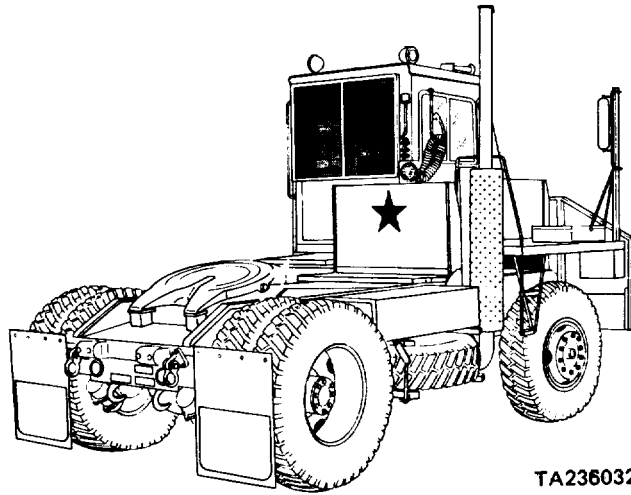

TA236032

RIGHT REAR VIEW

M878A1 Yard Tractor

V(VI Blank)

CHAPTER 1
INTRODUCTION

CHAPTER OVERVIEW

The purpose of this chapter is to give you standard data required in all manuals, to familiarize you with the purpose and capabilities of the vehicle, and to give you a brief description of its different systems and components.

Index

Section	Title	Page
I	General Information	1-1
II	Equipment Description and Data	1-3
III	Principles of Operation.....	1-5

Section I. GENERAL INFORMATION

	Para		Para
Scope	1-1	Reporting Equipment Improvement	
Maintenance, Forms, Record, and Reports.....	1-2	Recommendations (EIR)	1-5
Destruction of Army Materiel to Prevent Enemy Use	1-3	Warranty Information	1-6
Preparation for Storage or Shipment.....	1-4	Orientation.....	1-7
		Common Tools and Equipment	1-8
		Special Tools, TMDE, and Support Equipment.....	1-9
		Repair Parts	1-10

1-1. SCOPE

- a. Type of Manual. Organizational, Direct Support, and General Support Maintenance.
- b. Model Number and Equipment Name. M878A1, 4x2, Diesel Engine Driven, 43,500 Pounds Gross Vehicle Weight, Yard Type Tractor Truck.
- c. Purpose of Equipment. Movement of truck trailers within a terminal yard.

1-2. MAINTENANCE FORMS, RECORDS, AND REPORTS

Department of the Army forms and procedures used for equipment maintenance will be those prescribed by DA Pam 738-750, The Army Maintenance Management System (TAMMS).

1-3. DESTRUCTION OF ARMY MATERIEL TO PREVENT ENEMY USE

For destruction of army materiel to prevent enemy use, refer to TM 750-244-6.

1-4. PREPARATION FOR STORAGE OR SHIPMENT

Refer to paragraphs 2-89 thru 2-92 for preparation for storage or shipment.

1-5. REPORTING EQUIPMENT IMPROVEMENT RECOMMENDATIONS (EIR)

If your M878A1 tractor needs improvement let us know. Send us an EIR. You, the user, are the only one who can tell us what you don't like about your equipment. Let us know why you don't like the design. Put it on an SF 368 (Quality Deficiency Report). Mail it to us at: Commander, US Army Tank-Automotive Command, ATTN: DRSTA-MT, Warren, MI 48090. We'll send you a reply.

1-6. WARRANTY INFORMATION

The M878A1 tractor is warranted by Ottawa Truck Corporation for 15 months or 1500 hours of operation, whichever comes first. Warranty starts on the date found on DA Form 2410 or DA Form 2408-16 in the logbook. Report all defects in material or workmanship to your supervisor who will take appropriate action.

1-7. ORIENTATION

In this manual, right and left hand sides of the tractor are determined from the operator's seat facing toward the front of the tractor.

1-8. COMMON TOOLS AND EQUIPMENT

For authorized common tools and equipment refer to the Modified Table of Organization and Equipment (MTOE) applicable to your unit.

1-9. SPECIAL TOOLS, TMDE, AND SUPPORT EQUIPMENT

No special tools, TMDE, or support equipment is required.

1-10. REPAIR PARTS

Repair parts are listed and illustrated in the repair parts and special tools list (TM 9-2320-285-24P) covering organizational, direct support, and general support maintenance for this equipment.

Section II. EQUIPMENT DESCRIPTION AND DATA

	Para		Para
Equipment Characteristics, Capabilities, and Features.....	1-11	Equipment Data	1-13
Location and Description of Major Components	1-12	Safety, Care, and Handling.....	1-14

1-11. EQUIPMENT CHARACTERISTICS, CAPABILITIES, AND FEATURES

Refer to the separate Operator’s Manual, TM 9-2320-285-10, for equipment characteristics, capabilities, and features.

1-12. LOCATION AND DESCRIPTION OF MAJOR COMPONENTS

- a. Refer to the separate Operator’s Manual, TM 9-2320-285-10, for location and description of vehicle major components.
- b. Refer to para 2-74 for location of identification, instruction, and warranty plates.

1-13. EQUIPMENT DATA

Refer to separate Operator’s Manual, TM 9-2320-285-10, for tabulated equipment data.

1-14. SAFETY, CARE, AND HANDLING

When performing maintenance procedures, observe all warnings and cautions and take all appropriate safety measures. A summary of the warnings contained in this manual is located on the warning and first aid data page immediately following the cover page.

Section III. PRINCIPLES OF OPERATION

Yard Tractor	Para 1-15	Brakes	Para 1-23
Engine	1-16	Wheels	1-24
Fuel System.....	1-17	Steering System.....	1-25
Exhaust System.....	1-18	Frame and Towing Attachments	1-26
Cooling System	1-19	Springs and Shock Absorbers	1-27
Electrical System.....	1-20	Cab and Body.....	1-28
Transmission and Propeller		Accessories.....	1-29
Shaft.....	1-21	Fifth Wheel Hydraulic System.....	1-30
Axles.....	1-22	Cab Tilt Hydraulic System.....	1-31
		Gages.....	1-32

1-15. YARD TRACTOR

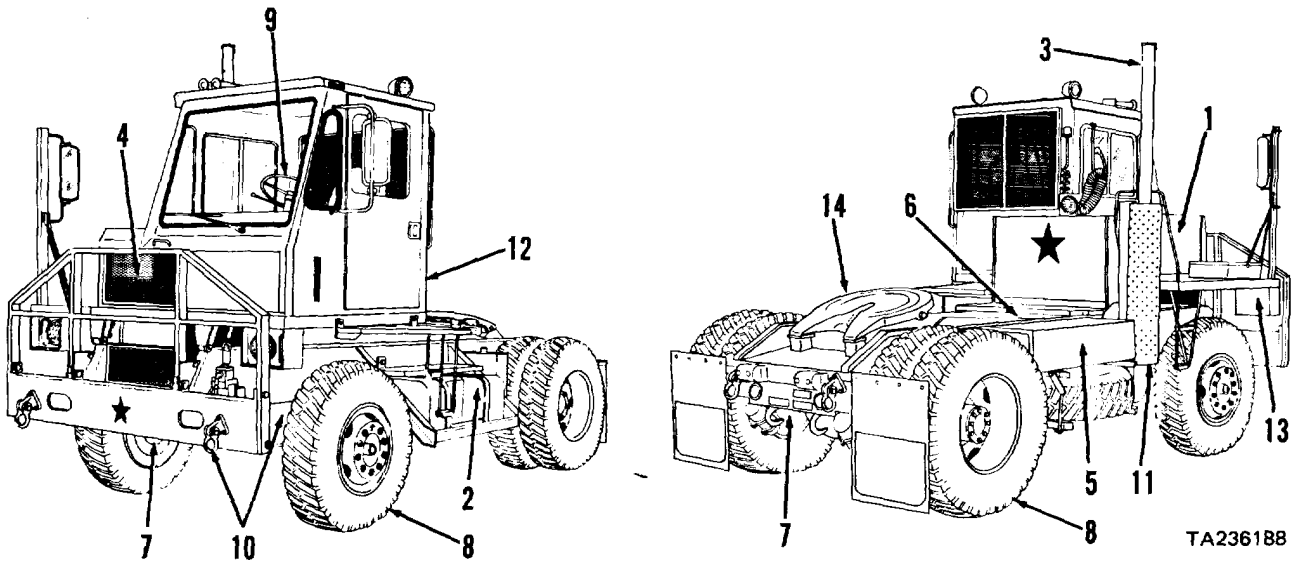

TA236188

1. ENGINE. Diesel engine, internal combustion power unit; engine has no carburetor or electrical ignition system, relies on heat of compressed air alone to ignite fuel; heat of diesel fuel is converted to work in engine cylinders.
2. FUEL SYSTEM. Fuel is pumped from fuel tank into fuel injectors, then sprayed into combustion chamber.
3. EXHAUST SYSTEM. Engine exhaust gases are expelled through muffler and exhaust stack mounted on right side of tractor; muffler aids in quieting engine noise.
4. COOLING SYSTEM. Cools engine by circulating coolant; cooling air is drawn through radiator by belt-driven fan; water pump draws coolant from radiator. Radiator is equipped with coolant recovery system.
5. ELECTRICAL SYSTEM. 12 volt, supplied by four wet-cell batteries in parallel; engine-driven, 90 ampere alternator supplies current. Key switch controls application of power to circuits.
6. POWER TRAIN. Consists of transmission, propeller shaft, differential, and rear axle; transmits motive power from engine to rear wheels.
7. BRAKES. Drum type, operated by air pressure; service brakes controlled by cab brake treadle, independent of parking brake control.

1-15. YARD TRACTOR (CONT)

- 8. WHEELS. Six 12:00 x 20, 16 ply tires plus spare; dual mounted rear tires; all tires and wheels same size.
- 9. STEERING SYSTEM. Includes steering wheel and column, steering gear, and hydraulic system for power assist.
- 10. FRAME AND TOWING ATTACHMENTS. Two flange beams extend the length of tractor; tow shackles and tie down hooks at front and rear of tractor are included.
- 11. SPRINGS AND SHOCK ABSORBERS. Two shock absorbers and two leaf spring assemblies, located at left and right front axle.
- 12. CAB AND BODY. Fully enclosed cab rubber mounted to cab deck; deck attached to frame by two pivot pins at front and two hydraulic latches at rear.
- 13. ACCESSORIES. Includes windshield washer and wiper, rearview mirrors, air horn, cab heater, and winterization system heaters.
- 14. HYDRAULIC SYSTEMS. Three hydraulic systems: fifth wheel hydraulic system to raise and lower fifth wheel boom, cab tilt hydraulic system to tilt and lower cab deck, and steering hydraulic system for power assist.

1-16. ENGINE

318 cubic inch, 6 cylinder, overhead 4-valve, 2 cycle diesel engine; engine-mounted oil filter and external oil filter remove impurities from engine lubrication system. engine oil sampling valve permits sampling of used engine oil for laboratory analysis. Engine provides mounting facilities for fan, air compressor, alternator, and power steering pump.

NOTE

Refer to TM 9-2815-205-34, Diesel Engine Maintenance Manual,, for detailed description of engine system.

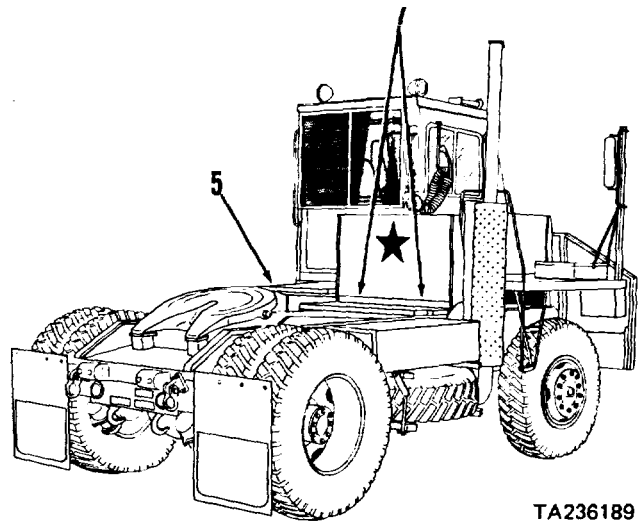
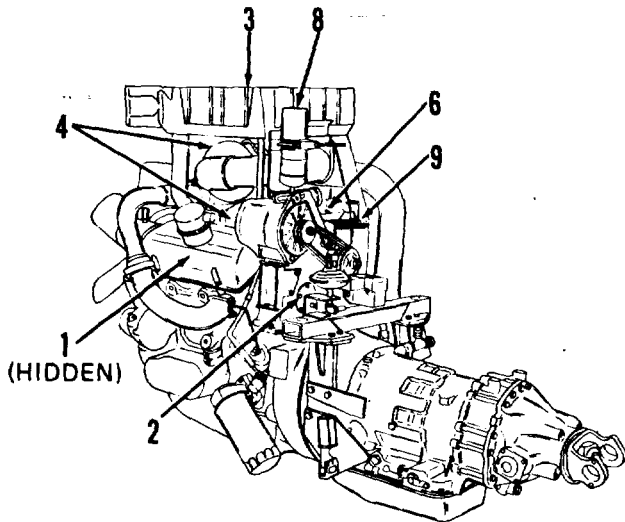

TA236189

- 1. FUEL INJECTORS. Six-injectors spray atomized fuel under pressure into combustion chamber.
- 2. FUEL PUMP. Engine driven, mechanical gear pump draws fuel from supply tank through primary and secondary fuel filters and sends fuel under pressure to fuel injectors.

1-17. FUEL SYSTEM (CONT)

3. AIR CLEANER AND RESTRICTION INDICATOR. Air cleaner traps dust and dirt from air and sends filtered air to turbocharger; restriction indicator, mounted on right instrument panel, monitors resistance to air flow due to trapped particles and displays red band when preset restriction level is reached.
4. TURBOCHARGER AND BLOWER ASSEMBLY. Blower assembly, mounted on top of engine block, uses two double-lobed rotors to deliver fresh air from turbocharger to engine; turbocharger, driven by engine exhaust gases, delivers amount of air that engine requires for combustion, determined by amount of engine exhaust.
5. FUEL TANK. 50 gallon capacity; mounted on left side of frame.
6. GOVERNOR. Mechanical, limiting-speed type governor, mounted on flywheel housing of engine, controls engine-idle speed and limits maximum engine operating speed.
7. FUEL FILTERS. Primary and secondary fuel filters remove impurities from fuel system.
8. ENGINE STARTING AID. Includes quick start switch, ether cylinder, ether solenoid, and tubing; aids engine starting in cold weather. When switch is operated, electrically-operated solenoid valve injects pre-measured shot of highly volatile ether into air intake system. Replaceable cylinder supplies ether.
9. ACCELERATOR AND THROTTLE LINKAGE. Controls engine speed through operation of accelerator pedal transmitted by linkage to engine governor.

1-18. EXHAUST SYSTEM

1. MUFFLER. Muffles engine noise; mounted vertically at right side of vehicle.
2. EXHAUST PIPES. Channel engine exhaust smoke and combustion by-products from engine turbocharger to muffler.

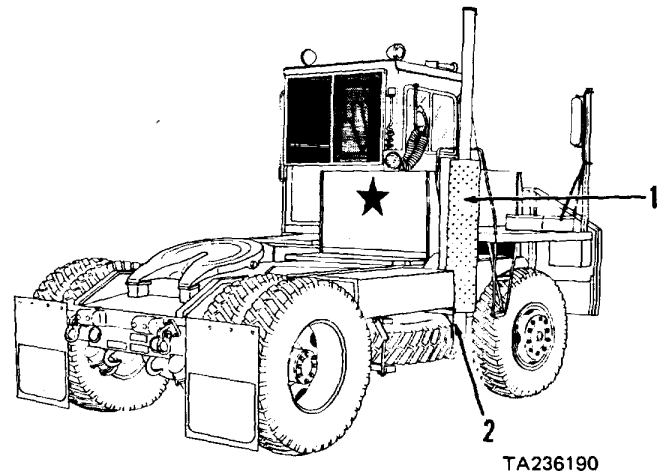

1-19. COOLING SYSTEM

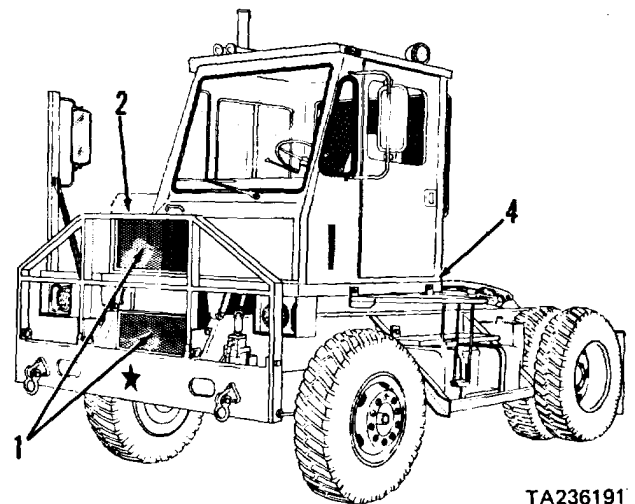
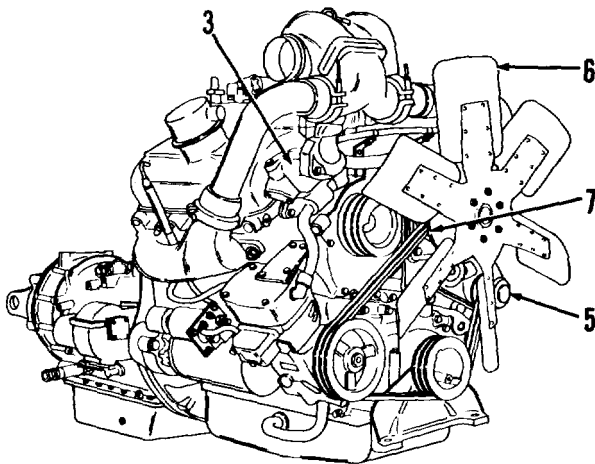

1-19. COOLING SYSTEM (CONT)

1. RADIATOR. Mounted at front of vehicle; cools engine coolant. Includes coolant recovery system. Bottom tank contains transmission cooler which cools transmission fluid.
2. RADIATOR SHROUD. Positioned around radiator; increases radiator cooling efficiency.
3. THERMOSTATS. Thermostats in water manifold aid quick engine warm-up by diverting coolant from radiator until coolant reaches a temperature of 170 degrees F.
4. COOLANT FILTER. Removes impurities from circulating coolant.
5. WATER PUMP. Driven by matched set of V-belts from engine camshaft pulley.
6. FAN. Mounted on fan clutch assembly at front of engine.
7. FAN CLUTCH ASSEMBLY. On-off type pneumatic clutch; controls engine temperature by turning fan on and off; pneumatically connected to solenoid. Solenoid is electrically connected to thermal switch.

1-20. ELECTRICAL SYSTEM

1. ALTERNATOR AND BELT. Engine-driven by matched set of V-belts; 90 ampere alternator charges batteries and supplies current for vehicle electrical circuits.
2. STARTER. Enclosed shift-type-lever starter motor; operated by solenoid mounted on starter.
3. INSTRUMENT PANELS. Refer to para 1-20a and 1-20b below for descriptions of indicators, lights, and switches mounted on instrument panels.
4. SWITCHES, TURN SIGNAL, ENGINE WARNING KIT, AND WATER LEVEL WARNING KIT. Switches include neutral start switch, back-up light switch, and service brakes and trailer hand brake stop light switches. Turn signal control lever operates steering column-mounted turn signal switch. Engine warning kit includes engine-mounted alarmstat sensor and oil pressure warning sensor. Water level warning kit includes engine-mounted

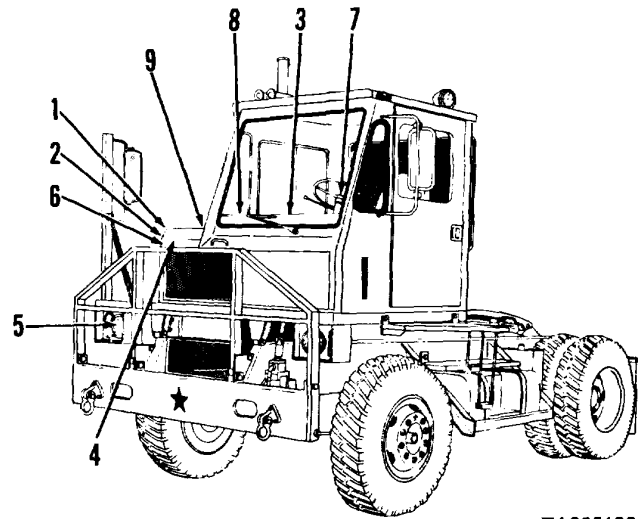

TA236192

5. LIGHTS. Mounted at front of vehicle are two headlights, two front turn indicator lights, and marker lights. Mounted at vehicle rear are two tail and stop lights. Floodlights are mounted at left and right cab roof and on rear cab guard.
6. SENDING UNITS. Includes fuel level sender, water temperature sender, oil pressure sender, and transmission temperature sender.
7. HORN AND SWITCH. Horn switch, operated by steering wheel horn button, sounds electric horn. Horn is mounted at front frame crossmember.
8. BATTERIES. Four 12 Volt wet-cell batteries in parallel supply vehicle operating voltage.
9. WIRING HARNESSSES. Eight wiring harnesses supply current to vehicle electrical components. Fuse block, located at cab interior, right hand side, provides circuit protection.

11-20. ELECTRICAL SYSTEM (CONT)

a. Instrument Panel Indicators.

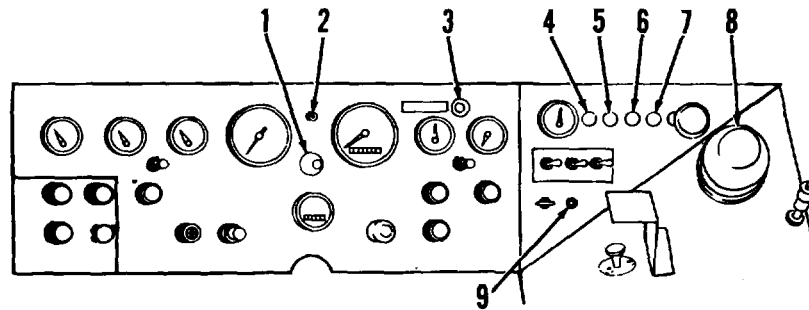

TA236193

1. TRANS/TORQUE CONVERTER LIGHT. Indicates red when transmission fluid temperature is too hot for normal operation; electrically connected to transmission temperature sender located at transmission, right hand side.
2. HIGH BEAM LIGHT. Indicates red when headlights are on high beam.
3. LOW FUEL INDICATOR. Indicates red when fuel level is too low for operation on 30% grades or side slopes of 10%; electrically connected to fuel level sender located in fuel tank and circuit board mounted behind front instrument panel.
4. WATER LEVEL WARNING LIGHT. Indicates red with drop in engine coolant; electrically connected to water level sensor mounted at engine rear.
5. WATER TEMP WARNING LIGHT. Indicates red with overheating of engine coolant; electrically connected to water temperature alarmstat located at front of engine, right hand side.
6. OIL PRESSURE WARNING LIGHT. Indicates red when engine lubricating oil pressure is too low for safe operation; electrically connected to oil pressure sensor located at engine, left hand side.
7. LOW AIR WARNING LIGHT. Indicates red, and buzzer sounds, when air system pressure is too low for safe operation; electrically connected to low air pressure switch, located under right instrument panel.
8. WARNING BELL. Sounds when WATER LEVEL, WATER TEMP, or OIL PRESSURE warning lamps light.
9. 24V INVERTER LIGHT. Indicates red when 24V INVERTER switch is turned to on position.

b. Instrument Panel Switches and Gage Lights.

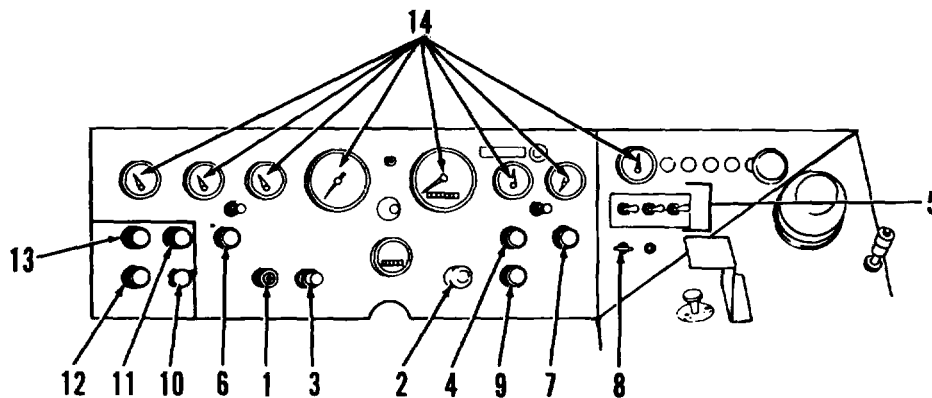

TA236194

1-20. ELECTRICAL SYSTEM (CONT)

b. Instrument Panel Switches and Gage Lights (cont).

1. IGNITION SWITCH. Three position switch applies power to vehicle electrical circuits. Turned to first clockwise detent position, applies power to all circuits except engine starter.
2. QUICK START SWITCH. Aids cold-weather starting; injects ether into air intake system.
3. ENGINE STOP SWITCH. Controls fuel shut-off solenoid on engine governor; stops fuel flow to engine.
4. HEADLIGHT SWITCH. Two position switch controls headlights and dash, gage, side marker, and parking lights; controls brightness of dash and gage lights. With trailer lighting cable connected, also controls trailer parking and side marker lights.
5. FLOOD LIGHT SWITCHES. Three independent switches control vehicle floodlights.
6. BLOWER SWITCH. Controls speed of cab heater fan.
7. TRAILER LIGHT SWITCH. With trailer lighting cable connected to 12 volt trailer, controls trailer interior lights.
8. 24V INVERTER SWITCH. Turns on 24 volt inverter to allow 24 volt trailer lighting cable to power 24 volt trailer.
9. WASHER BUTTON. Applies two streams of washing solvent to windshield.
10. WIPER CONTROL. Operates windshield wiper blade and speed of wiper.
11. TEMPERATURE CONTROL. Regulates amount of hot water flowing to cab heater.
12. DEFROSTER CONTROL. Allows heated air from cab heater to be directed through windshield defroster vents to windshield.
13. FRESH AIR CONTROL. Regulates amount of outside air applied to cab heater.
14. GAGE LIGHTS. Eight socket and bulb assemblies controlled by headlight switch.

1-21. TRANSMISSION AND PROPELLER SHAFT

1. TORQUE CONVERTER. Integral part of transmission; transmits and multiplies engine power.
2. TRANSMISSION. Automatic transmission provides five forward speeds and one reverse speed; includes torque converter, shift lockout cylinder, and control valve. Mechanical lock-out prevents shifting to or from reverse unless brake treadle is depressed.
3. CONTROL VALVE. Directs oil under pressure to the desired directional and speed clutch.
4. PROPELLER SHAFT. Telescoping tube with universal joint at each end; connects transmission and rear axle differential.

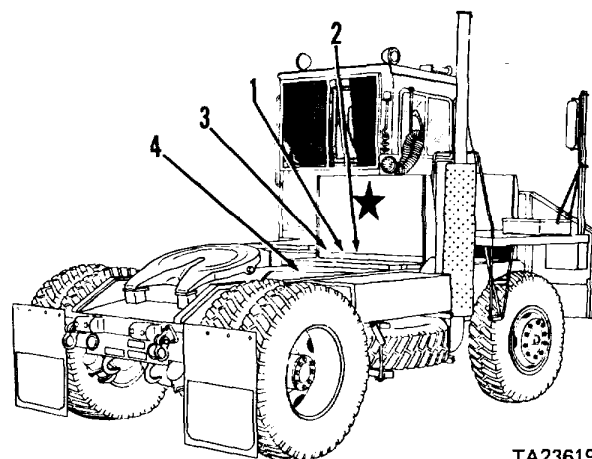

TA236195

1-22. AXLES

1. **FRONT AXLE.** I-beam type steerable axle connected to vehicle by two leaf springs and shock absorbers.
2. **REAR AXLE.** Mounted to vehicle frame through rubber pads; includes double-reduction drive unit and differential.
3. **DIFFERENTIAL.** Gear assembly mounted on rear axle housing; transmits motive power from propeller shaft to rear axle shaft.

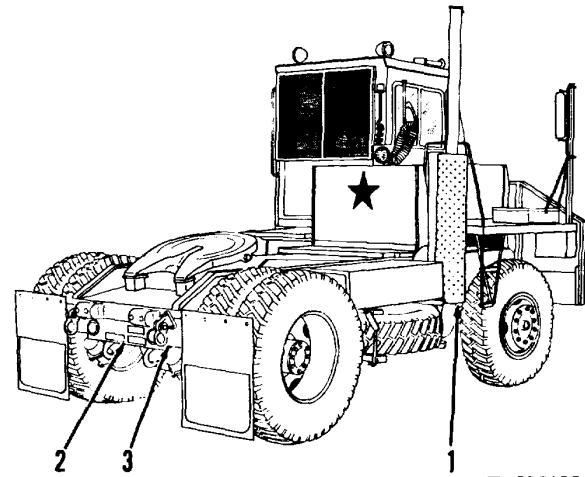

TA236196

1-23. BRAKES

1. **FRONT AXLE BRAKES.** Drum and shoe type, pneumatic brakes controlled by foot operated treadle valve; pressure on treadle valve determines amount of air pressure delivered to brakes.
2. **FRONT AXLE BRAKE AIR CHAMBERS.** Four air chambers; air is delivered to chambers through ratio reducing valve which reduces air pressure under non-emergency conditions. Air chambers deliver air pressure to front brakes.
3. **REAR AXLE BRAKES.** Drum and shoe type, pneumatic brakes controlled by foot operated treadle valve; pressure on treadle valve determines amount of air pressure delivered to brakes.

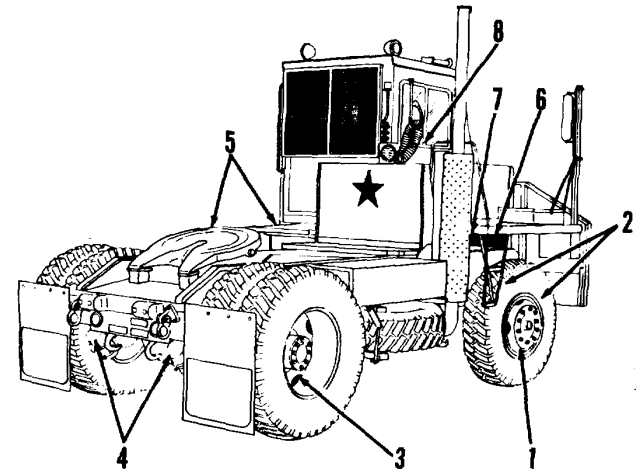

4. **REAR AXLE BRAKE AIR CHAMBERS.** Two air chambers deliver air pressure to rear brakes. Fail-safe spring type air chambers apply parking brake automatically with loss of air pressure.
5. **AIR RESERVOIRS.** Two air reservoirs, connected in series. Air from air compressor enters supply reservoir where it cools and water vapor condenses; dry air is then routed to service reservoir for use by vehicle pneumatic components. Automatic drain valve ejects water from supply reservoir.
6. **AIR COMPRESSOR, ALCOHOL EVAPORATOR, AND AIR STRAINER.** Liquid cooled, single acting, two cylinder in-line type air compressor includes governor, alcohol evaporator, and air strainer. Air strainer, mounted on air compressor intake adapter, filters impurities from air used by compressor. Alcohol evaporator delivers alcohol vapor to air compressor at intake adapter to increase air system efficiency during cold weather operation.
7. **GOVERNOR.** Regulates air compressor operation. When air pressure reaches pre-set maximum, governor halts air compressor operation; when air pressure reaches pre-set minimum, governor resumes air compressor operation.

1-23. BRAKES (CONT)

8. BRAKE CONTROLS. Brake treadle valve controls operation of front and rear service brakes. PARKING BRAKE valve, located at right instrument panel, controls vehicle spring brakes. With service and emergency hoses connected to trailer, brake treadle valve also controls trailer service brakes; and, trailer hand brake control, located at right hand side of steering column, applies trailer brakes without applying tractor brakes.

1-24. WHEELS

1. WHEEL. Provides mount for tire and rim; all same size.
2. TIRE. 12:00 by 20, 16 ply pneumatic type.

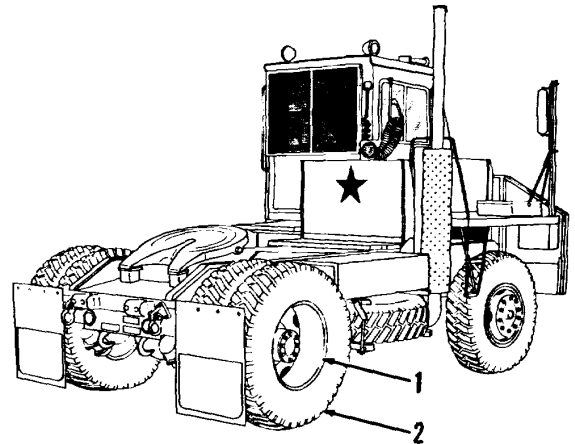

TA236397

1-25. STEERING SYSTEM

1. STEERING COLUMN. Includes steering shaft; provides mount for turn signal lever and light, steering wheel, and horn button; connects steering wheel to steering universal joint.
2. POWER STEERING GEAR. Includes hydraulic control valve; driven by steering universal joint, drives steering linkage using arm.
3. POWER STEERING PUMP. Rotary vane type pump forces hydraulic oil from power steering reservoir to steering gear control valve to provide steering power assist.

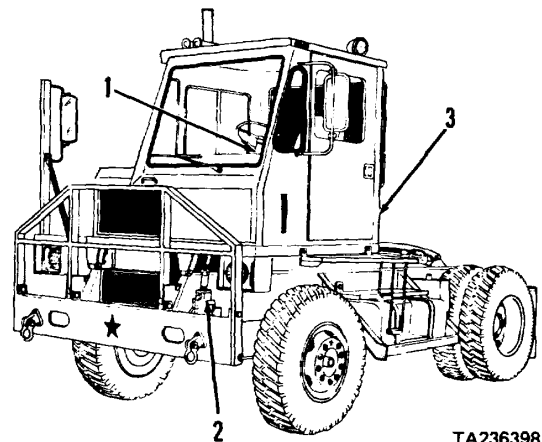

TA236398

1-26. FRAME AND TOWING ATTACHMENTS

1. **FRAME.** Two welded box section steel flange beams extend the length of tractor; provides mounting facilities for engine, transmission, axles, cab deck, and fifth wheel boom.
2. **SPARE TIRE CARRIER.** Located at right hand side of vehicle, under battery box. Pivoting hangers allow carrier to be lowered for spare tire removal.
3. **FIFTH WHEEL.** Mounted on fifth wheel boom, supports towed trailer; includes jaws for securing trailer kingpin; fifth wheel pivots around bushings in brackets welded to fifth wheel boom.

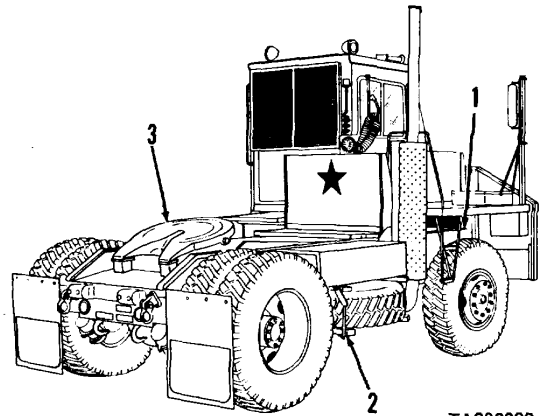

TA236399

1-27. SPRINGS AND SHOCK ABSORBERS

1. **SPRINGS AND SPRING SEATS.** Two semi-elliptical leaf springs attach front axle to frame; springs are attached to front axle through spring pads and attached to frame by shackles.
2. **SHOCK ABSORBERS.** Two, mounted between springs and frame. Shock absorbers, together with springs, frame-mounted rubber blocks, and rubber cab mounts cushion cab from jolts and bumps.

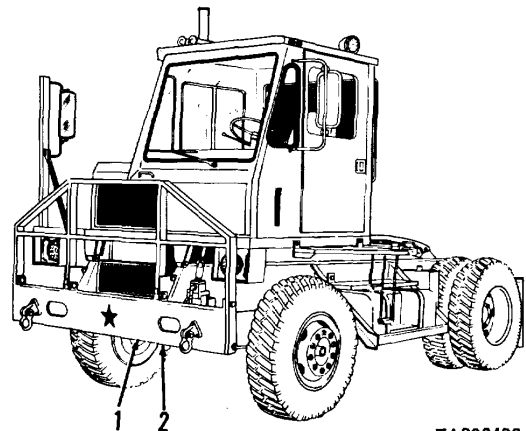

TA236400

1-28. CAB AND BODY

1. **BODY.** Includes cab deck, side step, rear platform, rear cab guard and heat shield, bumper and grille guard, and hood and rear enclosure.
2. **CAB.** Provides enclosure for operator; mounted on cab deck through rubber mounts, includes door with window and arm rest, windshield, right side and rear windows, rear window guard, and operator's seat.

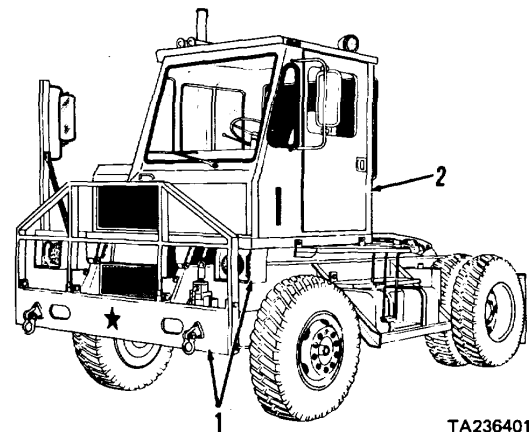

TA236401

1-29. ACCESSORIES

1. **WINDSHIELD WIPER.** Single wiper arm and blade, controlled by WIPER control located at front instrument panel; mounted at center of windshield, driven by pneumatic-operated motor assembly.
2. **WINDSHIELD WASHER.** Applies two streams of washer solvent to windshield; operation of WASHER button, located at front instrument panel, causes washer pump and reservoir, mounted on engine compartment rear grille, to deliver solvent to two washer nozzles located below windshield.

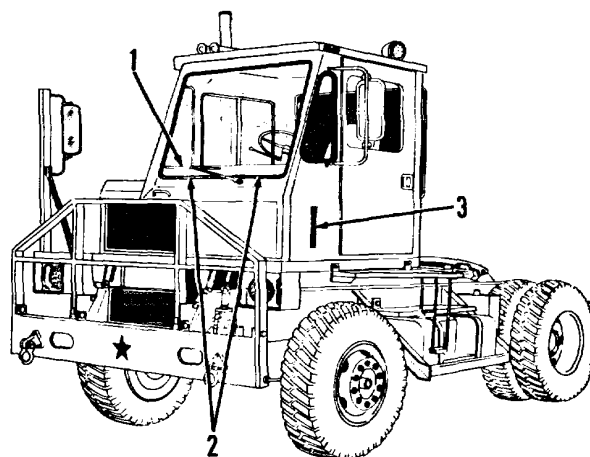

TA236402

3. **CAB HEATER.** Uses hot engine coolant and electric motor-driven blower to heat cab. Operation of defroster control allows cab heater air to be directed through defroster vents to windshield. In warm weather, with temperature control pushed in fully (no heat), operation of fresh air control allows outside air, entering through cab vents, to circulate through cab.

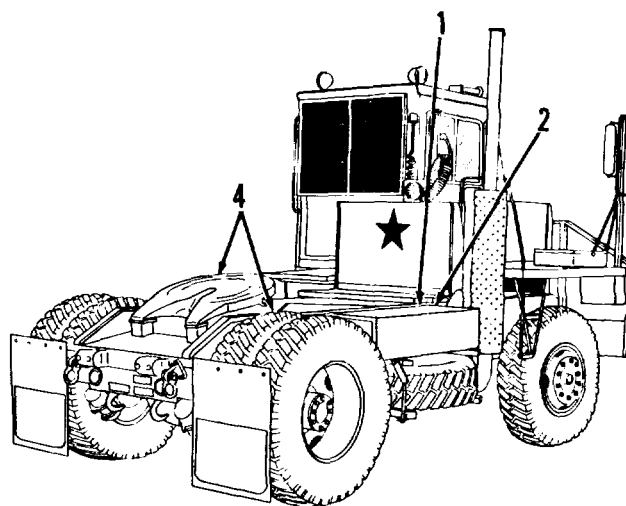
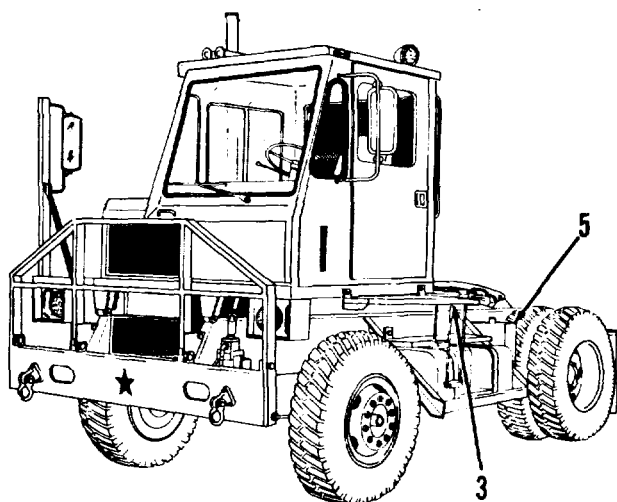
1-30. FIFTH WHEEL HYDRAULIC SYSTEM

TA236403

1. **HYDRAULIC PUMP.** Located at right hand side of transmission, supplies hydraulic oil to fifth wheel control valve.
2. **POWER TAKE-OFF.** Located at right hand side of transmission, drives hydraulic pump; controlled by PTO control, located at right corner instrument panel.
3. **FIFTH WHEEL CONTROL VALVE.** Regulates flow of hydraulic fluid to fifth wheel hydraulic cylinders.
4. **FIFTH WHEEL HYDRAULIC CYLINDERS.** Mounted to rear chassis and fifth wheel boom, raise and lower fifth wheel boom.
5. **HYDRAULIC RESERVOIR.** Mounted on chassis, behind fuel tank at left hand side of vehicle, supplies hydraulic fluid to fifth wheel hydraulic system.

1-31. CAB TILT HYDRAULIC SYSTEM

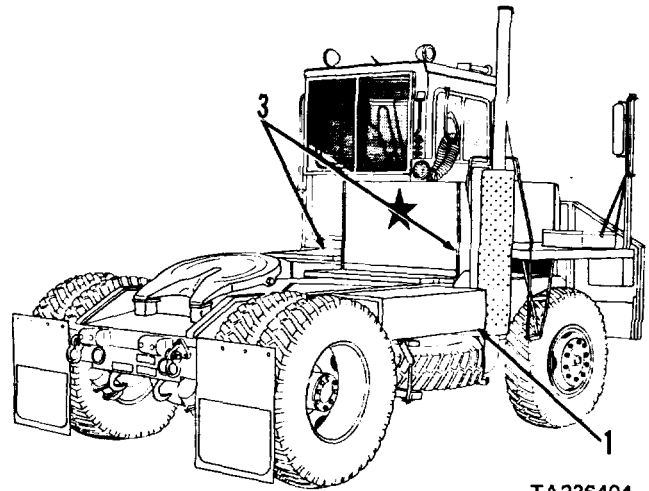
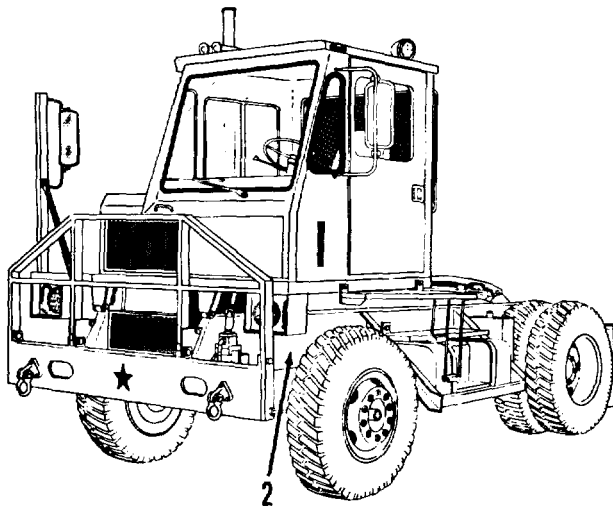

TA236404

1. HYDRAULIC PUMP. Mounted at right hand side of vehicle, supplies and regulates flow of transmission fluid to cab tilt cylinder and hydraulic latches.
2. HYDRAULIC CYLINDER. Mounted to frame and cab deck, raises and lowers cab deck.
3. HYDRAULIC LATCHES. Controlled by cab tilt hydraulic pump; engage hold down brackets mounted on cab deck to secure cab deck at normal operating position, or disengage hold down brackets to allow cab deck to be tilted.

1-32. GAGES

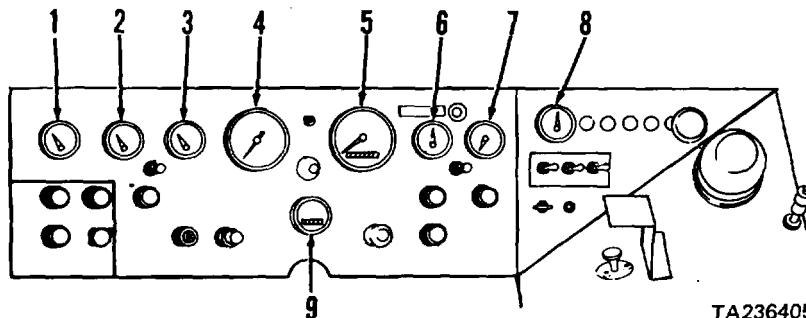

TA236405

1. VOLTMETER. Indicates electrical system voltage.
2. WATER TEMP GAGE. Indicates temperature of engine coolant; electrically connected to water temperature sender.
3. OIL PRESS GAGE. Indicates engine lubricating oil pressure; electrically connected to oil pressure sender.
4. TACHOMETER. Indicates engine speed in rpm; electrically connected to sender unit installed on drive assembly at engine rear.
5. SPEEDOMETER. Indicates vehicle speed and accumulated mileage; connected by cable to transmission-mounted gear assembly.
6. FUEL GAGE. Indicates fuel tank level; electrically connected to fuel level sender.
7. AIR PRESS GAGE. Indicates air system pressure; pneumatically connected to air system tee.
8. AMMETER. Indicates rate of battery charge or discharge.
9. HOURMETER. Indicates accumulated engine operating time; electrically operated, advances when ignition switch is turned to on position.

CHAPTER 2 ORGANIZATIONAL MAINTENANCE PROCEDURES

CHAPTER OVERVIEW

This chapter has some important information that you need to know about the organizational maintenance requirements of the vehicle. This information includes but isn't limited to:

- Servicing the vehicle upon receipt including inspection, unloading, unpacking, checking and deprocessing unpacked equipment, and preliminary servicing of the vehicle prior to turning it over to the operator.
- Preventive maintenance checks and services which should be performed as indicated. It is very important that you perform these checks and services at the interval indicated because only in this manner can you locate and fix a small problem before it results in complete failure of the vehicle.
- A complete troubleshooting index which will help you quickly locate all the troubleshooting data contained in this manual.
- Maintenance of the various systems/subsystems which the vehicle comprises. These systems/subsystems are listed in the chapter index below.

Index

Section	Title	Page
I	Service Upon Receipt.....	2-3
II	Preventive Maintenance Checks and Services (PMCS)	2-5
III	Troubleshooting Symptom Index.....	2-11
IV	Engine, Fuel, Exhaust, and Cooling Systems Maintenance.....	2-17
V	Electrical System Maintenance	2-166
VI	Power Train Maintenance	2-419
VII	Brake System Maintenance	2-518
VIII	Wheels and Steering System Maintenance	2-643
IX	Frame and Towing Attachments, Shock Absorbers, and Body and Cab Maintenance	2-672
X	Accessories Maintenance	2-759
XI	Hydraulic Systems Maintenance	2-861
XII	Gages Maintenance	2-906
XIII	Preparation for Storage or Shipment.....	2-938

2-1/(2-2 blank)

Section I. SERVICE UPON RECEIPT

	Para		Para
Service Upon Receipt of Materiel	2-1	Preliminary Servicing of Equipment	2-2

2-1. SERVICE UPON RECEIPT OF MATERIEL

- a. Preliminary Inspection. Inspect vehicle body and cab for damage to surfaces incurred during shipment. If damage is found, report the damage on DD Form 6, Packaging Improvement Report.
- b. Unloading. Vehicle is shipped unboxed and mobile on carrier with tiedowns at front and rear of frame.
 - (1) Remove blocking from front and rear of vehicle.
 - (2) Perform paragraphs 2-la, 2-lc, and 2-le(3).
 - (3) Remove tiedowns and remove vehicle from carrier.
- c. Unpacking. Remove tape, banding, paper, and other packing materials.
- d. Checking Unpacked Equipment.
 - (1) Inspect the equipment for damage incurred during shipment. If the equipment has been damaged, report the damage on DD Form 6, Packaging Improvement Report.
 - (2) Check the equipment against the packing slip to see if the shipment is complete. Report all discrepancies in accordance with the instructions of TM 38-750.
 - (3) Check to see whether the equipment has been modified.
 - (4) Check gages on instrument panel for broken glass or other damage.
 - (5) Check control levers for bent or broken condition.
 - (6) Check air cleaner for damage.
 - (7) Check engine accessories for loose connections or insecure mounting.
 - (8) Check wiring for loose connections, damaged insulation, or broken conductor.
 - (9) Check fittings, lines, and hoses for cracks, loose connections, and missing or broken parts.
 - (10) Check that all drain plugs are securely tightened.

2-1. SERVICE UPON RECEIPT OF MATERIEL (CONT)

- e. Deprocessing Unpacked Equipment.

WARNING

Dry cleaning solvent (P-D-680), used to clean parts is toxic and flammable. Wear protective goggles and gloves and use only in a well ventilated area. Avoid contact with skin, eyes, and clothes and don't breathe vapors. Do not use near open flame or excessive heat and don't smoke when using it. Failure to do so could cause serious injury. If you become dizzy while using cleaning solvent, get fresh air and medical attention immediately. If contact with skin or clothes is made, flush with large amounts of water. If contact with eyes is made, wash eyes with water and seek medical aid immediately.

(1) Removal of Protective Compounds. Remove preservative compounds from metal surfaces with cleaning solvent P-D-680. Check and ensure that all fill openings are clear.

(2) Cleaning. Clean all dust and dirt from seat, instrument panel, wiring, engine, and radiator.

(3) Lubrication. Lubricate the vehicle in accordance with LO 9-2320-285-12.

2-2. PRELIMINARY SERVICING OF EQUIPMENT

- a. Check engine oil level dipstick. Fill to FULL mark if level is low.
- b. Check that fuel gage indicates sufficient fuel. Add fuel if level is low.
- c. Check that coolant level is approximately 2 to 4 inches below top of coolant reservoir filler neck. Fill as necessary if level is low.
- d. Check that battery electrolyte level is above plates in all batteries. Add distilled water if level is low.
- e. Check transmission fluid level dipstick. Fill to FULL mark if level is low.
- f. Check that hydraulic oil level is at hydraulic reservoir screen. Add hydraulic oil if level is low.
- g. Perform before operation PMCS (refer to separate Operator's Manual, TM 9-2320-285-10).

Section II. PREVENTIVE MAINTENANCE CHECKS AND SERVICES (PMCS)

General	Para	Para
	Preventive Maintenance Checks	
.....	2-3	and Services 2-4

2-3. GENERAL

To ensure that the tractor is ready for operation at all times, it must be inspected within designated intervals so that defects may be discovered and corrected before they result in serious damage or failure. All deficiencies and shortcomings will be recorded as well as the corrective action taken on DA Form 2404 at the earliest possible opportunity.

2-4. PREVENTIVE MAINTENANCE CHECKS AND SERVICES

- a. The item numbers of the table indicate the sequence of the PMCS. Perform at the intervals shown below:
 - (1) Do your (A) PREVENTIVE MAINTENANCE once each year.
 - (2) Do your (H) PREVENTIVE MAINTENANCE at the hour interval listed.
 - (3) Do your (MO) PREVENTIVE MAINTENANCE once each month.
- b. If something doesn't work, troubleshoot it with the instructions in this manual or notify your supervisor.
- c. Always do your preventive maintenance in the same order so it gets to be a habit. Once you've had some practice, you'll spot anything wrong in a hurry.
- d. If anything looks wrong and you can't fix it, write it down on your DA Form 2404. If you find something seriously wrong, report it to direct support maintenance as soon as possible.

NOTE

Use your PMCS table Item no. column to get the number for the TM ITEM NO. column of DA Form 2404 (Equipment Inspection and Maintenance Worksheet) when recording the results of PMCS.

- e. When you do your PREVENTIVE MAINTENANCE, take along the tools you will need to make all the checks. Take along a rag, you'll always need at least one.

2-4. PREVENTIVE MAINTENANCE CHECKS AND SERVICES (CONT)**WARNING**

Dry cleaning solvent (P-D-680), used to clean parts is toxic and flammable. Wear protective goggles and gloves and use only in a well ventilated area. Avoid contact with skin, eyes, and clothes and don't breathe vapors. Do not use near open flame or excessive heat and don't smoke when using it. Failure to do so could cause serious injury. If you become dizzy while using cleaning solvent, get fresh air and medical attention immediately. If contact with skin or clothes is made, flush with large amounts of water. If contact with eyes is made, wash eyes with water and seek medical aid immediately.

Compressed air used for cleaning purposes will not exceed 30 psi. Use only with effective chip guarding and personal protective equipment (goggles/shield, gloves, etc).

(1) Keep it clean: Dirt, grease, oil, and debris only get in the way and may cover up a serious problem. Clean as you work and as needed. Use dry cleaning solvent P-D-680 on all metal surfaces. Use soap and water when you clean rubber or plastic material.

(2) Bolts, nuts, and screws: Check them for obvious looseness, missing, bent or broken condition. You can't try them all with a tool, of course, but look for chipped paint, bare metal, or rust around bolt heads. If you find one you think is loose, tighten it, or report it to direct support maintenance if you cannot tighten it.

(3) Welds: Look for loose or chipped paint, rust or gaps where parts are welded together. If you find a bad weld, report it to direct support maintenance.

(4) Electric wires and connectors: Look for cracked or broken insulation, bare wires, and loose or broken connectors. Tighten loose connectors and make sure the wires are in good shape.

(5) Hoses and fluid lines: Look for wear, damage, and leaks, and make sure clamps and fittings are tight.

Wet spots show leaks, of course. But a stain around a fitting or connector can mean a leak. If a leak comes from a loose fitting or connector, tighten it. If something is broken or worn out, either correct it or report it to direct support maintenance (refer to maintenance allocation chart).

f. It is necessary for you to know how fluid leakage affects the status of your vehicle. The following are definitions of the types/classes of leakage you need to know to be able to determine the status of your vehicle. Learn, then be familiar with them and REMEMBER - WHEN IN DOUBT, NOTIFY YOUR SUPERVISOR!

2-4. PREVENTIVE MAINTENANCE CHECKS AND SERVICES (CONT)

Leakage Definitions for Organizational PMCS

- Class I Seepage of fluid (as indicated by wetness or discoloration) not great enough to form drops.
- Class II Leakage of fluid great enough to form drops but not enough to cause drops to drip from item being checked/inspected.
- Class III Leakage of fluid great enough to form drops that fall from the item being checked/inspected.

CAUTION

EQUIPMENT OPERATION IS ALLOWABLE WITH MINOR LEAKAGES (CLASS I OR II). OF COURSE, CONSIDERATION MUST BE GIVEN TO THE FLUID CAPACITY IN THE ITEM/SYSTEM BEING CHECKED OR INSPECTED. WHEN IN DOUBT, NOTIFY YOUR SUPERVISOR.

WHEN OPERATING WITH CLASS I OR II LEAKS, CONTINUE TO CHECK FLUID LEVELS AS REQUIRED IN YOUR PMCS.

CLASS III LEAKS SHOULD BE REPORTED TO YOUR SUPERVISOR OR DIRECT SUPPORT MAINTENANCE.

2-4. PREVENTIVE MAINTENANCE CHECKS AND SERVICES (CONT)

MO - Monthly

A - Annually

H - Hours

Item no.	Interval			Item to be Inspected PROCEDURE: Check for and repair, fill or adjust as necessary
	MO	A	H	
1				<p>Perform Operator/Crew PMCS prior to or in conjunction with organizational PMCS if:</p> <p>a. There is a delay between the daily operation of the equipment and the Organizational PMCS.</p> <p>b. The regular operator is not assisting/participating.</p>
				<p>ENGINE</p> <p style="text-align: center;"><u>WARNING</u></p> <p>Compressed air used for cleaning or drying parts must not exceed 30 psi. Wear safety glasses when using compressed air. Failure to do so could cause serious injury to eyes and possible blindness. If you hurt your eyes or if a foreign object is blown into your eyes, get medical attention immediately.</p> <p>Do not operate engine for prolonged periods in an unventilated area. Internal combustion engines produce poisonous carbon monoxide gas which is extremely toxic if allowed to accumulate in a closed area.</p>
			100	a. Clean primary air cleaner element (Ref page 2-68).
			100	b. Check safety filter on restriction indicator and clean.
			300	c. Replace every third service interval (Ref page 2-68).
2			600	d. Perform engine tune-up (Ref TM 9-2815-205-34).
			600	e. Check governor with tachometer (Ref TM 9-2815-205-34).
				<p>DRIVE BELTS</p> <p>100 Check tension of belts, adjust as necessary (Ref pages 2-153 and 2-199).</p>
3	•		<p>REAR AXLE</p> <p>Check rear axle oil level (Ref page 2-511).</p>	

2-4. PREVENTIVE MAINTENANCE CHECKS AND SERVICES (CONT)

MO - Monthly

A - Annually

H - Hours

Item no.	Interval			Item to be Inspected PROCEDURE: Check for and repair, fill or adjust as necessary.
	MO	A	H	
4			300	FUEL FILTERS Replace secondary and primary fuel filters (Ref page 2-92).
5	•		300	TRANSMISSION a. Inspect for missing components, loose bolts, leakage, or damage. b. Lubricate transmission control cable (Ref page 2-459).
6			600	EXHAUST SYSTEM Check system for leaks (Ref pages 2-118 and 2-123).
7				HYDRAULIC SYSTEM <u>WARNING</u> Dry cleaning solvent (P-D-680), used to clean parts is toxic and flammable. Wear protective goggles and gloves and use only in a well ventilated area. Avoid contact with skin, eyes, and clothes and don't breathe vapors. Do not use near open flame or excessive heat and don't smoke when using it. Failure to do so could cause serious injury. If you become dizzy while using cleaning solvent, get fresh air and medical attention immediately. If contact with skin or clothes is made, flush with large amounts of water. If contact with eyes is made, wash eyes with water and obtain medical aid immediately.
8	•			Clean hydraulic reservoir breather cap (Ref page 2-897). BRAKES <u>WARNING</u> Do not use compressed air to clean brakes, brake linings contain asbestos. Do not breathe asbestos dust. To do so could cause serious respiratory injury.
		•		Check brake linings for uneven or excessive wear (Ref pages 2-542 and 2-552).

Section III. TROUBLESHOOTING SYMPTOM INDEX

2-5. GENERAL

This section contains a complete index of all troubleshooting data located within this manual. Included in this index is the paragraph/malfunction and page number where the troubleshooting procedure will be found.

NOTE

For troubleshooting of the engine and its components, refer to TM 9-2815-205-34. The engine troubleshooting provided in this manual is limited to those areas where it interfaces with other components of the vehicle.

2-6. TROUBLESHOOTING SYMPTOM INDEX

	Para/Malfunction	Page
ENGINE		
Engine hard to start or will not start	2-8/1	2-18
Engine starts but will not run	2-8/2	2-20
Engine lacks power	2-8/3,3-2/1	2-22,3-3
Engine cranks but does not start when quick start is activated	2-8/4	2-23
Excessive oil consumption	2-8/5	2-25
Low engine oil pressure	2-8/6	2-26
Excessive exhaust smoke	2-8/7	2-27
FUEL SYSTEM		
Low fuel pressure	2-9/1	2-28
Excessive fuel usage	2-9/2	2-29
EXHAUST SYSTEM		
Excessive exhaust noise	2-10/1	2-30
COOLING SYSTEM		
Engine overheats	2-11/1,3-3/1	2-31,3-3
Engine does not reach operating temperature	2-11/2,3-3/1	2-35,3-3
Coolant system not pressurized	2-11/3,3-3/2	2-36,3-4
Coolant not warmed when coolant heater connected to power source	2-11/4	2-36
CHARGING SYSTEM		
Alternator overcharging	2-17/1	2-169
Alternator undercharging	2-17/2	2-169
Alternator not operating properly	3-7/1	3-35
STARTING SYSTEM		
Engine will not start	2-18/1	2-169
Starter cranks continuously	2-18/2	2-171
Starter not operating properly	3-8/1	3-35
INSTRUMENT PANEL		
WATER LEVEL warning light and bell not operating properly	2-19/1	2-172
WATER TEMP warning light or bell not operating properly	2-19/2	2-173

12-6. TROUBLESHOOTING SYMPTOM INDEX (CONT)

TM 9-2320-285-24-1

	Para/Malfunction	Page
INSTRUMENT PANEL (cont)		
OIL PRESSURE warning light or bell not operating properly	2-19/3	2-174
LOW AIR warning light and buzzer not operating properly	2-19/4	2-175
LOW FUEL INDICATOR lamp does not light when fuel tank is empty	2-19/5	2-176
LOW FUEL INDICATOR lamp lights when fuel tank is full	2-19/6	2-177
Voltmeter inoperative	2-19/7	2-177
Ammeter inoperative	2-19/8	2-177
Dash lights and gage lights inoperative	2-19/9	2-178
Engine stop switch doesn't stop engine	2-19/10	2-180
LIGHT SYSTEMS		
Trailer lights inoperative (12-volt trailer)	2-20/1	2-180
Trailer lights inoperative (24-volt trailer)	2-20/2	2-182
Turn signal lights inoperative	2-20/3	2-184
Headlights inoperative	2-20/4	2-185
Marker lights and tail lights inoperative	2-20/5	2-186
SENDING UNITS		
WATER TEMP warning light and bell not operating properly	2-21/1	2-188
OIL PRESSURE warning light and bell not operating properly	2-21/2	2-188
LOW FUEL INDICATOR light and FUEL gage not operating properly	2-21/3	2-189
Vehicle stop lights won't operate	2-21/4	2-189
Trailer stop lights won't operate	2-21/5	2-189
HORN SYSTEM		
Electric horn does not sound	2-22/1	2-190
BATTERY SYSTEM		
Batteries require frequent filling	2-23/1	2-191
Batteries fail to maintain charge	2-23/2	2-192
TRANSMISSION		
Transmission leaking fluid	2-37/1	2-420
Transmission fluid dirty	2-37/2	2-421
Transmission fluid smells burned	2-37/3	2-422
Transmission fluid is foamy	2-37/4	2-422
Transmission overheating	2-37/5,3-14/2	2-423,3-89
No neutral start or vehicle starts in other than neutral	2-37/6	2-424
Linkage movement not definite; difficulty finding correct gear position	2-37/7	2-424
Vehicle creeps in neutral	2-37/8	2-425
Transmission in wrong gear according to position strip	2-37/9	2-425
Transmission fluid is milky	3-14/1	3-90
Low lubrication pressure	3-14/3	3-91
Low main pressure in all ranges	3-14/4	3-91
No response to shift lever movement	2-37/10,3-14/5	2-425,3-92
All automatic shifts occur at too high speed	3-14/6	3-92

2-6. TROUBLESHOOTING SYMPTOM INDEX (CONT)
--

	Para/Malfunction	Page
TRANSMISSION (cont)		
Individual shift (2-3, 3-4, 4-5) occurs at too high speed	3-14/7	3-92
All automatic shifts occur at too low speed	3-14/8	3-93
Individual shift (2-3, 3-4, 4-5) occurs at too low speed	3-14/9	3-93
Slow or erratic shifting	2-37/11,3-14/10	2-425,3-93
Rough shifting	2-37/12,3-14/11	2-426,3-93
Clutch slippage in all forward gears	2-37/13,3-14/12	2-426,3-94
Excessive creep in first and reverse	3-14/13	3-94
Insufficient creep in first and reverse	3-14/14	3-94
Excessive vibration	2-37/14,3-14/15	2-426,3-94
High stall speed	3-14/16	3-94
Low stall speed	3-14/17	3-95
PROPELLER SHAFT		
Excessive noise in propeller shaft	2-38/1	2-427
Excessive vibration in propeller shaft	2-38/2	2-427
FRONT AXLE		
Rapid or uneven tire wear	2-39/1,3-15/1	2-428,3-95
Hard steering	3-15/2	3-95
Cross tube ends wear rapidly	3-15/3	3-96
Steering arm ball stud heavily worn	3-15/4	3-96
Knuckle pins and bushings worn excessively	3-15/5	3-96
Front axle shimmys or vibrates	2-39/2,3-15/6	2-428,3-96
Continuous wheel noise	2-39/3	2-428
Hub leaks oil	2-39/4	2-429
REAR AXLE		
Lubricant leaking from differential breather	2-40/1	2-430
Continuous axle or wheel noise	2-40/2	2-430
Differential carrier assembly overheating	2-40/3	2-430
Axle noise when driving	2-40/4	2-431
Hub leaks oil	2-40/5	2-431
Lubricant leaking from differential carrier assembly	3-16/1	3-97
SERVICE BRAKE SYSTEM		
Front or rear axle brakes release slowly	2-46/1	2-520
Uneven or erratic front axle brakes	2-46/2	2-520
Uneven or erratic rear axle brakes	2-46/3	2-521
Front axle brakes automatic adjustment not operating	2-46/4	2-522
Front axle brakes dragging	2-46/5	2-523
Rear axle brakes dragging	2-46/6	2-524
Front axle brakes grabbing	2-46/7	2-526
Rear axle brakes grabbing	2-46/8	2-526
Front axle brakes linings wear unevenly	2-46/9	2-527
Rear axle brakes linings wear unevenly	2-46/10	2-528
Front axle brakes frozen or locked	2-46/11	2-529
Rear axle brakes frozen or locked	2-46/12	2-529
Insufficient brake force to stop vehicle (front axle brakes)	2-46/13	2-530
(rear axle brakes)	2-46/14	2-531

2-6. TROUBLESHOOTING SYMPTOM INDEX (CONT)

	Para/Malfunction	Page
SERVICE BRAKE SYSTEM (cont)		
Front axle brakes squeak or groan, or scraping noise when applied	2-46/15	2-531
Rear axle brakes squeak or groan, or scraping noise when applied	2-46/16	2-532
AIR BRAKE SYSTEM		
Rapid pressure drop after engine is shut down (brakes released)	2-47/1	2-533
(brakes applied)	2-47/2	2-533
Pressure builds up slowly	2-47/3	2-534
Pressure won't build up to normal	2-47/4	2-534
Parking (spring) brakes won't release	2-47/5	2-535
AIR COMPRESSOR		
Pressure too high, or air compressor won't cut out	2-48/1,3-22/1	2-535,3-161
Pressure builds up slowly	2-48/2,3-21/3	2-535,3-154
Air compressor knocks	2-48/3,3-22/2	2-536,3-161
TRAILER BRAKE LINES AND COUPLINGS		
Trailer brakes do not release	2-49/1	2-536
Trailer service brakes do not function (cab guard)	2-49/2	2-537
(rear of tractor)	2-49/3	2-538
TREADLE VALVE AND BRAKE CONTROLS		
Rapid pressure drop after engine is shut down (brakes released)	3-21/1	3-154
(brakes applied)	3-21/2	3-154
Pressure builds up slowly	3-21/3	3-154
Pressure too high, or compressor won't cut out		3-21/4 3-155
Parking (spring) brakes won't release	3-21/5	3-155
Parking (spring) brake won't apply	3-21/6	3-157
Front and rear service brakes release slowly	3-21/7	3-158
Front service brakes release slowly	3-21/8	3-158
Rear service brakes release slowly	3-21/9	3-158
Trailer brakes do not release	3-21/10	3-159
Trailer service brakes do not function (cab guard)	3-21/11	3-159
(rear of tractor)	3-21/12	3-161
WHEELS AND TIRES		
Tire wearing unevenly	2-55/1	2-644
Noisy or bumping sound while traveling	2-55/2	2-644
STEERING SYSTEM		
Tractor wanders over road	2-56/1,3-27/3	2-646,3-227
No recovery	2-56/2,3-27/4	2-646,3-228
Shimmy	2-56/3,3-27/5	2-646,3-230
High steering effort in both directions	2-56/4,3-27/8	2-647,3-233
Lost motion at steering wheel	2-56/5,3-27/9	2-647,3-234
Power steering pump making noise	2-56/6,3-27/11	2-648,3-236
Steering wheel stops turning before tractor front wheels hit stop blocks	3-27/1	3-226
Too much play in steering wheel	3-27/2	3-227
Oversteering or darting	3-27/6	3-230

2-6. TROUBLESHOOTING SYMPTOM INDEX (CONT)
--

	Para/Malfunction	Page
STEERING SYSTEM (cont)		
High steering effort in one direction	3-27/7	3-231
Power steering pump not delivering oil	3-27/10	3-235
FRAME AND TOWING ATTACHMENTS		
Tire carrier will not lower	2-60/1	2-673
Tow shackles will not pivot	2-60/2	2-673
Boom platform will not latch or unlatch	2-60/3	2-673
SHOCK ABSORBERS		
Vehicle vibrates excessively during bumps	2-61/1	2-673
Harsh bump when vehicle bottoms	2-61/2	2-674
BODY AND CAB		
Seat bottoms or tops out too easily	2-62/1	2-674
Seat wobbles	2-62/2	2-674
Door sticks, or will not open or close	2-62/3	2-675
Hood will not latch or unlatch	2-62/4	2-675
Radiator access panel will not latch or unlatch	2-62/5	2-675
Tool box will not open or close	2-62/6	2-676
Cab grille guard will not tilt forward	2-62/7	2-676
Cab difficult to raise or wobbles when raised	2-62/8	2-677
Seat squeaks or binds in up and down travel	3-32/1	3-297
Seat bounces excessively after a bump, or bottoms or tops out too easily	3-32/2	3-298
Harsh bump when seat bottoms or tops out	3-32/3	3-298
Seat binds, or does not slide smoothly, when adjusted backward or forward	3-32/4	3-298
Weight adjustment handle feels loose, has no tension	3-32/5	3-298
Seat or back cushions are separating from pans	3-32/6	3-299
Seat has collapsed	3-32/7	3-299
Door sticks, or will not open or close	3-32/8	3-299
Door window will not raise or lower, or will not travel smoothly	3-32/9	3-300
Right side or rear window will not close fully	3-32/10	3-300
Right side or rear window will not slide or will not slide smoothly	3-32/11	3-301
Cab drafty	3-32/12	3-301
Cab vibrates excessively	3-32/13	3-301
FIFTH WHEEL		
Fifth wheel jaws don't open	3-30/1	3-295
SPRINGS AND SPRING SEATS		
Vehicle vibrates excessively during bumps	3-31/1	3-297
Springs squeak or groan	3-31/2	3-297
WINDSHIELD WIPER AND WASHER		
No fluid is sprayed on windshield when washer switch is pressed	2-67/1	2-760
Wiper doesn't move	2-67/2	2-761
HEATERS		
Cab drafty	2-68/1	2-762
Fresh air door will not open or close	2-68/2,3-37/2	2-762,3-400
Cab heater doesn't heat cab	2-68/3,3-37/1	2-763,3-399
Windshield will not defrost	2-68/4,3-37/3	2-764,3-400

2-6. TROUBLESHOOTING SYMPTOM INDEX (CONT)
--

	Para/Malfunction	Page
HEATERS (cont)		
Batteries not warmed when battery warmers connected to power source	2-68/5	2-765
Coolant not warmed when coolant heater connected to power source	2-68/6	2-766
Engine oil heater does not operate	2-68/7	2-768
All winterization system heaters not operating	2-68/8	2-769
FIFTH WHEEL HYDRAULIC SYSTEM		
Fifth wheel doesn't lift	2-76/1,3-40/1	2-862,3-408
Fifth wheel lifts slowly	2-76/2,3-40/2	2-863,3-410
Fifth wheel creeps downward	2-76/3,3-40/3	2-864,3-411
Fifth wheel doesn't lower	2-76/4,3-40/4	2-865,3-411
Hydraulic oil foaming	2-76/5,3-40/5	2-865,3-413
Excessive hydraulic pump noise	2-76/6	2-865
Hydraulic oil overheating	2-76/7,3-40/6	2-866,3-413
Hydraulic reservoir overflows	2-76/8	2-866
CAB TILT HYDRAULIC SYSTEM		
Cab won't raise to 45 degrees	2-77/1,3-41/1	2-867,3-414
Cab won't lower or stops part way down	2-77/2,3-41/2	2-867,3-414
Hydraulic latches lock before cab is all the way down	2-77/3	2-867
Hydraulic latches won't lock	2-77/4	2-867
Hydraulic latches or hydraulic cylinder leak fluid	3-41/3	3-414
Hydraulic pump leaks fluid at filler plug or vent	3-41/4	3-414
SPEEDOMETER		
Pointer moves erratically or scraping noise is heard	2-81/1	2-907
TACHOMETER		
Tachometer inoperative or does not indicate correct engine speed	2-82/1	2-908
PRESSURE GAGES		
WATER TEMP, OIL-PRESS, or FUEL gage inoperative	2-83/1	2-908
AIR PRESS gage doesn't indicate correct air pressure	2-83/2	2-909
HOURMETER		
Hourmeter inoperative	2-84/1	2-910

Section IV. ENGINE, FUEL, EXHAUST, AND COOLING SYSTEMS MAINTENANCE

This section contains the information you need to maintain the:

- Engine
- Fuel System
- Exhaust System
- Cooling System

It gives you instructions on how to troubleshoot problems and repair or replace the components that are within the scope of organizational maintenance.

	Para		Para
Troubleshooting Symptom Index.....	2-7	Fuel Filters	2-13c
Engine Troubleshooting	2-8	Quick Start	2-13d
Fuel System Troubleshooting	2-9	Accelerator and Throttle	
Exhaust System Troubleshooting.....	2-10	Linkage	2-13e
Cooling System Troubleshooting.....	2-11	Exhaust System Maintenance	2-14
Engine Maintenance	2-12	Exhaust Pipes	2-14a
Engine Servicing	2-12a	Muffler and Exhaust Stack	2-14b
Draining and Refilling Engine		Cooling System Maintenance	2-15
Crankcase	2-12b	Radiator	2-15a
Engine-Mounted Oil Filter	2-12c	Servicing	2-15a(1)
External Oil Filter and Lines	2-12d	Testing	2-15a(2)
Dipstick and Tube	2-12e	Coolant Filter	2-15b
Engine Oil Sampling Valve	2-12f	Servicing	2-15b(1)
Fuel System Maintenance	2-13	Removal	2-15b(2)
Air Cleaner Assembly and		Hoses	2-15c
Restriction Indicator	2-13a	Fan and Drive Belts	2-15d
Fuel Tank, Lines and Fittings	2-13b	Fan Clutch Control System	2-15e
Fuel Tank	2-13b(1)	Coolant Recovery System	2-15f
Lines and Fittings 2-13b(2)			

NOTE

Notify direct support maintenance (refer to TM 9-2815-205-34) for maintenance and repair of the engine fuel pump assembly, air inlet, thermostats, water manifold, and water pump.

2-7. TROUBLESHOOTING SYMPTOM INDEX

	Para/Malfunction	Page
ENGINE		
Engine hard to start or will not start	2-8/1	2-18
Engine starts but will not run	2-8/2	2-20
Engine lacks power	2-8/3	2-22
Engine cranks but does not start when quick start is activated	2-8/4	2-23
Excessive oil consumption	2-8/5	2-25
Low engine oil pressure	2-8/6	2-26
Excessive exhaust smoke	2-8/7	2-27
FUEL SYSTEM		
Low fuel pressure	2-9/1	2-28
Excessive fuel usage	2-9/2	2-29
EXHAUST SYSTEM		
Excessive exhaust noise	2-10/1	2-30
COOLING SYSTEM		
Engine overheats	2-11/1	2-31
Engine does not reach operating temperature	2-11/2	2-35
Coolant system not pressurized	2-11/3	2-36
Coolant not warmed when coolant heater connected to power source	2-11/4	2-36

2-8. ENGINE TROUBLESHOOTING

MALFUNCTION
 TEST OR INSPECTION
 CORRECTIVE ACTION

1. ENGINE HARD TO START OR WILL NOT START

Step 1. Check ambient temperature.

WARNING

Do not use ether switch without cranking engine. Over-charge of ether starting fluid can cause explosion of engine air intake system.

- a. If ambient temperature is below 40 degrees F, use ether switch to aid engine starting (refer to Operator's Manual, TM 9-2320-285-10).
- b. If ambient temperature is above 40 degrees F and engine will not start, go to step 5 below.
- c. If ambient temperature is above 40 degrees F and engine is hard to start, go to step 2 below.

2-8. ENGINE TROUBLESHOOTING (CONT)

MALFUNCTION

TEST OR INSPECTION

CORRECTIVE ACTION

1. ENGINE HARD TO START OR WILL NOT START (Cont)

Step 2. Check if air cleaner restriction indicator red band is in view.

- a. If red band is in view, go to step 3 below.
- b. If red band is not in view, go to step 5 below.

Step 3. Shut down engine, press reset button on top of restriction indicator, and check that red band disappears from view.

- a. If red band does not disappear from view with engine shut down and reset button depressed, replace air cleaner restriction indicator (para 2-13a).
- b. If red band disappears from view, go to step 4 below.

Step 4. Start engine.

- a. If red band reappears when engine is cranked, service air cleaner (para 2-13a).
- b. If red band does not reappear, go to step 5 below.

Step 5. Check if fuel level is low (LOW FUEL INDICATOR lamp lights and FUEL gage indicates empty (E)).

- a. If fuel level is low, fill tank with proper grade of fuel (para 2-13b(1)).
- b. If fuel level is not low, go to step 6 below.

Step 6. Check for incorrect or contaminated fuel in fuel tank (if contaminated, fuel will have a milky-white coloring).

- a. If fuel is contaminated, drain, clean, and fill fuel tank (para 2-13b(l)) and replace fuel filters (para 2-13c).
- b. If fuel is not contaminated, go to step 7 below.

Step 7. Check fuel filters for clogged condition.

- a. If fuel filters are clogged, replace (para 2-13c).
- b. If fuel filters are not clogged, go to step 8 below.

2-8. ENGINE TROUBLESHOOTING (CONT)

MALFUNCTION
TEST OR INSPECTION
CORRECTIVE ACTION

1. ENGINE HARD TO START OR WILL NOT START (Cont)

Step 8. Disconnect battery ground cable (para 2-34a). Place an ammeter in series with battery positive cable: disconnect battery positive cable from starter terminal (para 2-25b) and connect battery positive cable to ammeter; then run a test cable from ammeter to starter terminal. Reconnect battery ground cable (para 2-34a). Turn key switch to start position while watching ammeter. Ammeter shall indicate 120 to 150 amperes.

- a. If ammeter indicates more than 150 amperes, repair or replace starter (para 2-25b).
- b. If ammeter indicates less than 120 amperes, go to step 9 below.
- c. If ammeter indicates 120 to 150 amperes, go to step 10 below.

Step 9. Check specific gravity of battery electrolyte (para 2-34a).

- a. If specific gravity is low, charge batteries.
- b. If specific gravity of one cell differs excessively from specific gravity of another cell in same battery, replace battery (para 2-34a).
- c. If specific gravity is correct, replace battery cables (para 2-34a).

Step 10. Check engine cranking speed.

- a. If cranking speed seems low, troubleshoot electrical system (para 2-18).
- b. If cranking speed does not seem low, notify direct support maintenance (refer to TM 9-2815-205-34 for detailed troubleshooting of the engine and its components).

2. ENGINE STARTS BUT WILL NOT RUN

Step 1. Check if air cleaner restriction indicator red band is in view.

- a. If red band is in view, go to step 2 below.
- b. If red band is not in view, go to step 4 below.

2-8. ENGINE TROUBLESHOOTING (CONT)

MALFUNCTION

TEST OR INSPECTION

CORRECTIVE ACTION

2. ENGINE STARTS BUT WILL NOT RUN (Cont)

Step 2. Shut down engine, press reset button on top of restriction indicator, and check that red band disappears from view.

- a. If red band does not disappear from view with engine shut down and reset button depressed, replace air cleaner restriction indicator (para 2-13a).
- b. If red band disappears from view, go to step 3 below.

Step 3. Start engine.

- a. If red band reappears when engine is cranked, service air cleaner (para 2-13a).
- b. If red band does not reappear, go to step 4 below.

Step 4. Check if fuel level is low (LOW FUEL INDICATOR lamp lights and FUEL gage indicates empty (E)).

- a. If fuel level is low, fill tank with proper grade of fuel (para 2-13b(1)).
- b. If fuel level is not low, go to step 5 below.

Step 5. Check fuel filters for clogged condition.

- a. If fuel filters are clogged, replace (para 2-13c).
- b. If fuel filters are not clogged, go to step 6 below.

Step 6. Check for incorrect or contaminated fuel in fuel tank (if contaminated, fuel will have a milky-white coloring).

- a. If fuel is contaminated, drain, clean, and fill fuel tank (para 2-13b(1)) and replace fuel filters (para 2-13c).
- b. If fuel is not contaminated, go to step 7 below.

Step 7. Have an assistant depress and release accelerator pedal. Watch for accelerator cable movement at the engine governor.

- a. If accelerator cable does not move, repair or replace accelerator and throttle linkage (para 2-13e).
- b. If accelerator cable moves, notify direct support maintenance.

2-8. ENGINE TROUBLESHOOTING (CONT)

MALFUNCTION
TEST OR INSPECTION
CORRECTIVE ACTION

3. ENGINE LACKS POWER

Step 1. Check if air cleaner restriction indicator red band is in view.

- a. If red band is in view, go to step 2 below.
- b. If red band is not in view, go to step 4 below.

Step 2. Shut down engine, press reset button on top of restriction indicator, and check that red band disappears from view.

- a. If red band does not disappear from view with engine shut down and reset button depressed, replace air cleaner restriction indicator (para 2-13a).
- b. If red band disappears from view, go to step 3 below.

Step 3. Start engine.

- a. If red band reappears when engine is cranked, service air cleaner (para 2-13a).
- b. If red band does not reappear, go to step 4 below.

Step 4. Check exhaust pipes, muffler, and exhaust stack for foreign matter.

- a. If foreign matter is present, remove (para 2-14a and 2-14b).
- b. If foreign matter is not present, go to step 5 below.

Step 5. Shut down engine.

Have an assistant fully depress accelerator pedal; watch throttle arm rotation.

With accelerator pedal fully depressed, try to extend throttle arm rotation manually.

- a. If throttle arm moves farther when rotated manually, adjust or repair throttle linkage (para 2-13e).
- b. If throttle arm does not move farther when rotated manually, go to step 6 below.

Step 6. Check fuel filter for clogged condition.

- a. If fuel filters are clogged, replace (para 2-13c).
- b. If fuel filters are not clogged, go to step 7 below.

2-8. ENGINE TROUBLESHOOTING (CONT)

MALFUNCTION
TEST OR INSPECTION
CORRECTIVE ACTION

3. ENGINE LACKS POWER (Cont)

Step 7. Check for incorrect or contaminated fuel in fuel tank (if contaminated, fuel will have a milky-white coloring).

- If fuel is contaminated, drain, clean, and fill fuel tank (para 2-13b(1)) and replace fuel filters (para 2-13c).
- If fuel is not contaminated, notify direct support maintenance.

4. ENGINE CRANKS BUT DOES NOT START WHEN QUICK START IS ACTIVATED

Step 1. Remove quick start cylinder (para 2-13d). Shake quick start cylinder to check for presence of ether.

WARNING

Cylinder contains ether which is highly flammable and under pressure. Do not puncture cylinder or discard in an open fire. Failure to follow this precaution could cause severe injury.

- If quick start cylinder is empty, replace (para 2-13d).
- If quick start cylinder contains ether, go to step 2 below.

Step 2. Turn key switch to on position.
Have an assistant press quick start switch on instrument panel.
Listen for a click at ether valve.
Turn key switch to off position.

- If you hear a click at ether valve, go to step 3 below.
- If you do not hear a click at ether valve, go to step 4 below.

WARNING

Compressed air must not exceed 30 psi. Wear safety glasses when using compressed air. Failure to do so could cause serious injury to eyes and possible blindness. If you hurt your eyes or if a foreign object is blown into your eyes, seek medical attention immediately.

Step 3. Remove lines and fittings between ether valve and intake manifold (para 2-13d).
Use 10 psig compressed air to check for obstructions.

2-8. ENGINE TROUBLESHOOTING (CONT)

MALFUNCTION
TEST OR INSPECTION
CORRECTIVE ACTION

4. ENGINE CRANKS BUT DOES NOT START WHEN QUICK START IS ACTIVATED (Cont)

Step 3. a. If lines or fittings are obstructed, replace (para 2-13d).

(cont)

b. If lines and fittings are not obstructed, go to step 4 below.

Step 4. Remove atomizer from air inlet housing. Check atomizer for obstructions using 10 psig compressed air.

a. If atomizer is obstructed, replace (para 2-13d).

b. If atomizer is not obstructed, go to step 5 below.

Step 5. With engine water temperature below 70 degrees F, apply 10 psig compressed air to one port of control valve. Check for air at other port of control valve.

a. If air does not escape from other port, replace control valve (para 2-13d).

b. If air escapes from other port, go to step 6 below.

Step 6. Raise instrument panel (para 2-26g(l)).

Connect a voltmeter between chassis ground and one terminal of quick start switch.

Turn key switch to on position.

If voltmeter indicates 12 Vdc, disconnect voltmeter probe from quick start switch terminal and connect to other quick start switch terminal.

Voltmeter shall indicate zero Vdc.

Depress quick start switch; voltmeter shall indicate 12 Vdc.

a. If voltmeter does not indicate 12 Vdc, replace quick start switch (para 2-26a(2)).

b. If voltmeter indicates 12 Vdc, go to step 7 below.

Step 7. Turn key switch to off position.

Check continuity of wiring between quick start switch terminal and ether -valve terminal.

Check continuity of wiring between ether valve terminal and chassis ground connection.

a. If continuity is obtained, replace ether valve (para 2-13d).

b. If continuity is not obtained, replace defective wiring (para 2-13d).

2-8. ENGINE TROUBLESHOOTING (CONT)

MALFUNCTION
TEST OR INSPECTION
CORRECTIVE ACTION

5. EXCESSIVE OIL CONSUMPTION

Step 1. Check for engine oil leaks at engine oil filter.

- a. If oil leaks are observed, tighten or replace filter element (para 2-12c).
- b. If oil leaks are not observed, go to step 2 below.

Step 2. Check for engine oil leaks at external oil filter and lines and fittings.

- a. If oil leaks are observed, tighten fittings, plug, and stud (para 2-12d) and replace gasket (para 2-12d); if hoses are leaking, replace (para 2-12d).
- b. If oil leaks are not observed, go to step 3 below.

Step 3. Check for engine oil leaks at engine oil sampling valve.

- a. If oil leaks are observed, tighten plug or replace engine oil sampling valve (para 2-12f); if hoses are leaking, replace (para 2-12f).
- b. If oil leaks are not observed, go to step 4 below.

Step 4. Check for engine oil leaks at oil pan drain plug.

- a. If oil leaks are observed, tighten or replace drain plug (para 2-12b).
- b. If oil leaks are not observed, go to step 5 below.

Step 5. Check for engine oil leaks at engine oil heater.

- a. If oil leaks are observed, tighten or replace heater (para 2-73d).
- b. If oil leaks are not observed, go to step 6 below.

Step 6. Check for oil leaks at engine oil pressure sensor and sender units.

- a. If oil leaks are observed, tighten or replace unit (para 2-32a).
- b. If oil leaks are not observed, notify direct support maintenance (refer to TM 9-2815-205-34 for troubleshooting of the engine and its components).

2-8. ENGINE TROUBLESHOOTING (CONT)

MALFUNCTION	TEST OR INSPECTION	CORRECTIVE ACTION
-------------	--------------------	-------------------

6. LOW ENGINE OIL PRESSURE

Step 1. Check if OIL PRESSURE warning lamp lights and OIL PRESS gage indicates low oil pressure.

- a. If OIL PRESSURE warning lamp lights, but OIL PRESS gage indicates normal oil pressure, OIL PRESSURE warning lamp may be defective; troubleshoot (para 2-19). If OIL PRESSURE warning lamp is not defective, troubleshoot OIL PRESS gage (para 2-83). Then go to step 2 below.
- b. If OIL PRESS gage indicates low oil pressure, but OIL PRESSURE warning lamp does not light, OIL PRESS gage may be defective; troubleshoot (para 2-83). If OIL PRESS gage is not defective, troubleshoot OIL PRESSURE warning lamp (para 2-19). Then go to step 2 below.
- c. If OIL PRESS gage indicates low oil pressure and OIL PRESSURE warning lamp lights, go to step 3 below.

Step 2. After troubleshooting in steps 1a or 1b above has restored agreement between OIL PRESSURE warning lamp and OIL PRESS gage, check OIL PRESSURE warning lamp and OIL PRESS gage indications.

- a. If OIL PRESSURE warning lamp lights and OIL PRESS gage indicates low oil pressure, go to step 3 below.
- b. If OIL PRESSURE warning lamp does not light and OIL PRESS gage indicates normal pressure, no further action is required.

Step 3. Check engine oil level.

- a. If oil level is too low, add oil to FULL mark on dipstick (para 2-12b).
- b. If oil level is correct, go to step 4 below.

Step 4. Check engine oil for dirty condition.
Remove dipstick, wipe it between thumb and forefinger and check if oil feels gritty and looks dirty.

- a. If oil feels gritty or looks dirty, drain engine oil (para 2-12b), replace engine oil filters (para 2-12c and 2-12d), and refill crankcase with clean oil (para 2-12b).
- b. If engine oil does not feel gritty or look dirty, go to step 5 below.

2-8. ENGINE TROUBLESHOOTING (CONT)

MALFUNCTION	TEST OR INSPECTION	CORRECTIVE ACTION
-------------	--------------------	-------------------

6. LOW ENGINE OIL PRESSURE (Cont)

Step 5. Check if engine oil is too light.

- a. If engine oil is too light, drain engine oil (para 2-12b), replace engine oil filters (para 2-12c and 2-12d), and refill crankcase with correct weight oil (para 2-12b).
- b. If engine oil is not too light, check for engine oil leaks (refer to Malfunction 5 above).

7. EXCESSIVE EXHAUST SMOKE

Step 1. Check if air cleaner restriction indicator red band is in view.

- a. If red band is in view, go to step 2 below.
- b. If red band is not in view, go to step 4 below.

Step 2. Shut down engine, press reset button on top of restriction indicator, and check that red band disappears from view.

- a. If red band does not disappear from view with engine shut down and reset button depressed, replace air cleaner restriction indicator (para 2-13a).
- b. If red band disappears from view, go to step 3 below.

Step 3. Start engine.

- a. If red band reappears when engine is cranked, service air cleaner (para 2-13a).
- b. If red band does not reappear, go to step 4 below.

Step 4. Check for incorrect or contaminated fuel in fuel tank (if contaminated, fuel will have a milky-white coloring).

- a. If fuel is incorrect grade or contaminated, drain, clean, and fill fuel tank (para 2-13b(1)) and replace fuel filters (para 2-13c).
- b. If fuel is not contaminated, go to step 5 below.

2-8. ENGINE TROUBLESHOOTING (CONT)

MALFUNCTION
TEST OR INSPECTION
CORRECTIVE ACTION

7. EXCESSIVE EXHAUST SMOKE (Cont)

Step 5. Examine exhaust system for visible signs of oil leaking from exhaust system, and check maintenance records for possible excessive oil consumption.

If exhaust system leaks oil, or records show high oil consumption, notify direct support maintenance (refer to TM 9-2815-205-34 for troubleshooting of the engine and its components).

2-9. FUEL SYSTEM TROUBLESHOOTING

MALFUNCTION
TEST OR INSPECTION
CORRECTIVE ACTION

1. LOW FUEL PRESSURE

WARNING

Diesel fuel is highly combustible. Do not smoke or allow open flames or sparks into the area. Death or severe injury may result if personnel fail to observe this precaution. If you are burned, obtain medical aid immediately.

Step 1. Check for fuel leaks at lines and fittings between fuel tank, primary fuel filter, and engine.

- a. If leaks are observed, tighten fittings; if hoses are leaking, replace (para 2-13b(l)).
- b. If leaks are not observed, go to step 2 below.

Step 2. Check for fuel leaks at fittings and hoses between fuel filters and engine.

- a. If leaks are observed, tighten fittings; if hoses are leaking, replace (para 2-13b(2)).
- b. If leaks are not observed, go to step 3 below.

2-9. FUEL SYSTEM TROUBLESHOOTING (CONT)
--

MALFUNCTION	TEST OR INSPECTION	CORRECTIVE ACTION
-------------	--------------------	-------------------

1. LOW FUEL PRESSURE (Cont)

Step 3. Replace primary and secondary fuel filters (para 2-13c); be sure to fill fuel filters 2/3 full with clean diesel fuel. Start engine and operate at 1200 rpm for 15 to 20 minutes. Loosen filters one at a time and check if filter is full of fuel.

- a. If filters are not full of fuel, this indicates an air leak between filters and fuel tank; remove and inspect fuel lines and fittings (para 2-13b(2)); replace if damaged (para 2-13b(2)).
- b. If fuel filters are full of fuel, go to step 4 below.

Step 4. Disconnect fuel return hose (para 2-13b(l)) from fuel tank. Place open end of hose in a five gallon container. Start engine and operate at 1200 rpm. Hold end of fuel return hose under fuel in container. Check for air bubbles rising to surface of fuel in container.

- a. If air bubbles are observed, tighten fuel line connections between secondary fuel filter and fuel pump (para 2-13b(2)).
- b. If air bubbles are not observed, notify direct support maintenance (refer to TM 9-2815-205-34 for troubleshooting of the engine and its components).

2. EXCESSIVE FUEL USAGE

WARNING

Diesel fuel is highly combustible. Do not smoke or allow open flames or sparks into the area. Death or severe injury may result if personnel fail to observe this precaution. If you are burned, obtain medical aid immediately.

Step 1. Check fuel lines for leakage or damage.

- a. If fuel lines are leaking or damaged, replace (para 2-13b(2)).
- b. If fuel lines are not leaking or damaged, go to step 2 below.

Step 2. Check fuel tank for leakage or damage.

- a. If fuel tank is leaking or damaged, replace (para 2-13b(l)).
- b. If fuel tank is not leaking or damaged, go to step 3 below.

2-9. FUEL SYSTEM TROUBLESHOOTING (CONT)

MALFUNCTION
TEST OR INSPECTION
CORRECTIVE ACTION

2. EXCESSIVE FUEL USAGE (Cont)

Step 3. Check if air cleaner restriction indicator red band is in view.

- a. If red band is in view, go to step 4 below.
- b. If red band is not in view, notify direct support maintenance (refer to TM 9-2815-205-34 for troubleshooting of the engine and its components).

Step 4. Shut down engine, press reset button on top of restriction indicator, and check that red band disappears from view.

- a. If red band does not disappear from view, with engine shut down and reset button depressed, replace air cleaner restriction indicator (para 2-13a).
- b. If red band disappears from view, go to step 5 below.

Step 5. Start engine.

- a. If red band reappears when engine is cranked, service air cleaner (para 2-13a).
- b. If red band does not reappear, notify direct support maintenance (refer to TM 9-2815-205-34 for troubleshooting of the engine and its components).

2-10. EXHAUST SYSTEM TROUBLESHOOTING

MALFUNCTION
TEST OR INSPECTION
CORRECTIVE ACTION

1. EXCESSIVE EXHAUST NOISE

Check muffler and exhaust pipes for cracks or holes.

- a. If muffler or exhaust pipes are cracked or perforated, replace (para 2-14a and 2-14b).
- b. If muffler and exhaust pipes are not cracked or perforated, notify direct support maintenance (refer to TM 9-2815-205-34 for troubleshooting of the engine and its components).

2-11. COOLING SYSTEM TROUBLESHOOTING

MALFUNCTION
TEST OR INSPECTION
CORRECTIVE ACTION

1. ENGINE OVERHEATS

WARNING

Remove radiator cap slowly to relieve pressure before completely removing when engine is hot. Failure to follow this procedure could cause severe injury. If you are scalded by steam, seek medical aid immediately.

Step 1. Check coolant level of radiator and coolant reservoir.

- a. If coolant level is low, add coolant (para 2-15a(1)).
- b. If coolant level is not low, go to step 2 below.

Step 2. Pressure test radiator cap (para 2-15a(2)).

- a. If radiator cap pressure is not 6 to 9 pounds, or if pressure drops rapidly, replace radiator cap.
- b. If radiator cap pressure is 6 to 9 pounds, and remains steady for at least 30 seconds before dropping, go to step 3 below.

Step 3. Check if radiator fins are clogged.

- a. If radiator fins are clogged, clean (para 2-15a(1)).
- b. If radiator fins are not clogged, go to step 4 below.

Step 4. Check coolant filter and hoses for leaks.
Check at top of filter element between filter head and filter element gasket for leakage.

- a. If leaks are observed, repair or replace defective components (para 2-15b(2)).
- b. If leaks are not observed, go to step 5 below.

Step 5. Check for leaks in coolant heater, coolant heater pump, cab heater, and hoses.

- a. If heaters or hoses are leaking, replace (para 2-15e, 2-73a, or 2-73b).
- b. If leaks are not observed, go to step 6 below.

2-11. COOLING SYSTEM TROUBLESHOOTING (CONT)
--

MALFUNCTION
TEST OR INSPECTION**CORRECTIVE ACTION**

1. ENGINE OVERHEATS (Cont)

Step 6. Check fan belts for proper tension.

Depress fan belts midway between fan pulley and crankshaft pulley.
Fan belts should deflect approximately 1/2 inch.

- a. If fan belts do not deflect approximately 1/2 inch, adjust tension (para 2-15d).
- b. If fan belts deflect approximately 1/2 inch, go to step 7 below.

Step 7. Inspect fan belts for damage or wear.

Check if fan belts are covered in oil or riding deeply in pulley groove.

- a. If any of the above conditions are observed, replace fan belts (para 2-15d).
- b. If none of the above conditions are observed, go to step 8 below.

Step 8. With key switch turned to on position, engine shut down, and at least 100 psi pressure in air system, try to rotate fan manually.

- a. If fan does not rotate, or fan belts slip, go to step 9 below.
- b. If fan rotates, and fan belts do not slip, fan drive assembly is defective; notify direct support maintenance.

Step 9. Check fan blade assembly for damage.

- a. If fan blade assembly is damaged, replace (para 2-15d).
- b. If fan blade assembly is not damaged, go to step 10 below.

WARNING

Remove radiator cap slowly to relieve pressure before completely removing when engine is hot. Failure to follow this procedure could cause severe injury. If you are scalded by steam, seek medical aid immediately.

2-11. COOLING SYSTEM TROUBLESHOOTING (CONT)
--

MALFUNCTION**TEST OR INSPECTION****CORRECTIVE ACTION**

1. ENGINE OVERHEATS (Cont)

- Step 10. Idle engine, remove radiator cap, and observe coolant. Check if coolant moves, indicating water pump is operating.
- If coolant does not move, notify direct support maintenance (refer to TM 9-2815-205-34 for repair or replacement of water pump).
 - If coolant moves, go to step 11 below.
- Step 11. With engine temperature below 180 degrees F, disconnect thermal switch lead at thermal switch (para 2-15e). Turn key switch to on position. Momentarily connect thermal switch lead to thermal switch; an audible click should be heard at solenoid, indicating proper operation.
- If audible click is heard, go to step 13 below.
 - If audible click is not heard, go to step 12 below.
- Step 12. With engine temperature below 180 degrees F, and key switch turned to on position, use a voltmeter to check for 12 Vdc at both terminals of thermal switch.
- If voltage is present at both terminals, go to step 13 below.
 - If voltage is not present at one terminal, go to step 14 below.
 - If voltage is not present at either terminal, notify direct support maintenance.
- Step 13. With key switch turned to off position, check continuity of solenoid using an ohmmeter: disconnect ground wire from alternator (para 2-24) and unplug connector above left hand valve cover (para 2-15e).
- If continuity is not obtained, replace solenoid (para 2-15e).
 - If continuity is obtained, go to step 14 below.

2-11. COOLING SYSTEM TROUBLESHOOTING (CONT)**MALFUNCTION****TEST OR INSPECTION****CORRECTIVE ACTION****1. ENGINE OVERHEATS (Cont)**

Step 14. With engine temperature below 180 degrees F, connect ohmmeter across thermal switch terminals (thermal switch lead remains disconnected at thermal switch.) Ohmmeter should indicate zero ohms with engine cool. Start engine and watch WATER TEMP gage; when gage indicates 195 degrees F, ohmmeter should indicate open circuit (infinity).

- a. If ohmmeter does not indicate zero ohms when engine is cool, or does not indicate open circuit (infinity) when WATER TEMP gage indicates 195 degrees F, replace thermal switch (para 2-15e).
- b. If ohmmeter indicates zero ohms when engine is cool, and indicates open circuit (infinity) when WATER TEMP gage indicates 195 degrees F, disconnect ohmmeter from thermal switch and reconnect thermal switch lead (para 2-15e). Then go to step 15.

WARNING

Wear safety glasses, and stand clear of loosened air line fitting. High pressure air can propel debris at high speed, causing eye injury or blindness.

Step 15. With key switch turned to on position, engine shut down, and at least 100 psi pressure in air system, carefully disconnect air line from outlet side of solenoid.

- a. If air escapes from solenoid, solenoid is defective; replace (para 2-15e).
- b. If air does not escape from solenoid, go to step 16 below.

Step 16. Have assistant momentarily turn key switch to off position. Watch solenoid.

- a. If air does not escape from solenoid, replace solenoid (para 2-15e).
- b. If air escapes from solenoid, notify direct support maintenance (refer to TM 9-2815-205-34 for troubleshooting of the engine and its components).

2-11. COOLING SYSTEM TROUBLESHOOTING (CONT)
--

MALFUNCTION**TEST OR INSPECTION****CORRECTIVE ACTION**

2. ENGINE DOES NOT REACH OPERATING TEMPERATURE

- Step 1. Disconnect thermal switch lead at thermal switch (para 2-15e). Turn key switch to on position. Momentarily connect thermal switch lead to thermal switch; an audible click should be heard at solenoid, indicating proper operation.
- If audible click is heard, go to step 3 below.
 - If audible click is not heard, go to step 2 below.
- Step 2. With key switch turned to on position, use a voltmeter to check for 12 Vdc at both terminals of thermal switch.
- If voltage is present at both terminals, go to step 3 below.
 - If voltage is not present at one terminal, go to step 4 below.
 - If voltage is not present at either terminal, notify direct support maintenance.
- Step 3. With key switch turned to off position, check continuity of solenoid using an ohmmeter: disconnect ground wire from alternator (para 2-24) and unplug connector above left hand valve cover (para 2-15e).
- If continuity is not obtained, replace solenoid (para 2-15e).
 - If continuity is obtained, go to step 5 below.
- Step 4. With engine temperature below 180 degrees F, connect ohmmeter across thermal switch terminals (thermal switch lead remains disconnected at thermal switch.) Ohmmeter should indicate zero ohms with engine cool. Start engine and watch WATER TEMP gage; when gage indicates 195 degrees F, ohmmeter should indicate open circuit (infinity).
- If ohmmeter does not indicate zero ohms when engine is cool, or does not indicate open circuit (infinity) when WATER TEMP gage indicates 195 degrees F, replace thermal switch (para 2-15e).
 - If ohmmeter indicates zero ohms when engine is cool, and indicates open circuit (infinity) when WATER TEMP gage indicates 195 degrees F, disconnect ohmmeter from thermal switch and reconnect thermal switch lead (para 2-15e). Then go to step 7 below.

2-11. COOLING SYSTEM TROUBLESHOOTING (CONT)
--

MALFUNCTION**TEST OR INSPECTION****CORRECTIVE ACTION****2. ENGINE DOES NOT REACH OPERATING TEMPERATURE (Cont)****WARNING**

Wear safety glasses, and stand clear of loosened air line fitting. High pressure air can propel debris at high speed, causing eye injury or blindness.

- Step 5. With key switch turned to on position, engine shut down, and at least 100 psi pressure in air system, carefully disconnect air line from outlet side of solenoid.
- If air escapes from solenoid, solenoid is defective; replace (para 2-15e).
 - If air does not escape from solenoid, go to step 6 below.
- Step 6. Have assistant momentarily turn key switch to off position. Watch solenoid.
- If air escapes from solenoid, go to step 7 below.
 - If air does not escape from solenoid, replace solenoid (para 2-15e).
- Step 7. With key switch turned to on position, engine shut down, and at least 100 psi pressure in air system, try to rotate fan manually.
- If fan does not rotate, notify direct support maintenance.
 - If fan rotates, notify direct support maintenance (refer to TM 9-2815-205-34 for troubleshooting of the engine and its components).

3. COOLANT SYSTEM NOT PRESSURIZED

Pressure test radiator cap (para 2-15a(2)).

- If radiator cap pressure is not 6 to 9 pounds, or if pressure drops rapidly, replace radiator cap.
- If radiator cap pressure is 6 to 9 pounds, and remains steady for at least 30 seconds before dropping, notify direct support maintenance.

4. COOLANT NOT WARMED WHEN COOLANT HEATER CONNECTED TO POWER SOURCE

Refer to para 2-68 to troubleshoot coolant heater and pump.

2-12. ENGINE MAINTENANCE

a. Engine Servicing. This task provides a summary of the tools, materials/parts, personnel required, and procedures that must be performed when servicing the engine.

INITIAL SETUP:

Tools

No. 1 Common Organizational Maintenance
 Tool Kit
 Socket wrench set
 Adjustable open end wrench
 Screwdriver
 Strap type filter wrench

Oil filter FSCM 72582 PN 25010495
 External oil filter pack FSCM 37099 PN 2095
 Cover gasket FSCM 37099 PN 2788
 Primary fuel filter element FSCM 72582 PN 25010778
 Secondary fuel filter element FSCM 72582 PN 2501776

Materials/Parts

Cleaning solvent Item 1, Appendix C
 Clean cloths Item 2, Appendix C
 Engine oil Item 24, Appendix C
 Antifreeze Item 25, Appendix C
 Battery electrolyte Item 36, Appendix C

Air filter FSCM 21585 PN C45800
 Precleaner FSCM 21585 PN L60308

Personnel Required

Wheel Vehicle Mechanic MOS 63B

Task No.	Task	Task Ref.	Troubleshooting Ref. No. (para)
1.	Maintain engine crankcase oil level	2-12b	2-8
2.	Maintain coolant level	2-15a(l)	2-11
3.	Maintain battery electrolyte level	2-34a	2-23
4.	Sample engine oil	2-12f	2-8
5.	Drain and refill crankcase	2-12b	2-8
6.	Replace engine oil filter element	2-12c	2-8
7.	Replace external oil filter pack	2-12d	2-8
8.	Replace fuel filter elements	2-13c	2-9
9.	Replace air cleaner element and precleaner	2-13a	2-8
10.	Adjust drive belts	2-15d 2-24	2-11, 2-48 2-17
11.	Replace coolant filter	2-15b(1)	2-11
12.	Replace ether starting aid cylinder	2-13d	2-8

2-12. ENGINE MAINTENANCE (CONT)

b. Draining and Refilling Engine Crankcase.

This task covers draining and refilling engine crankcase.

INITIAL SETUP:

Tools

No. 1 Common Organizational Maintenance
Tool Kit
Combination wrench set

Materials/Parts

Sixteen quarts
engine oil Item 24, Appendix C

Personnel Required

Wheel Vehicle Mechanic MOS 63B

References

2-12c Engine oil filter change
 detailed procedure
2-12d External oil filter pack change
 detailed procedure

Equipment Condition

Paragraph Condition Description
Vehicle parked on level
surface, engine warm and
turned off, and parking brake
applied.
Cab tilted 45 degrees.

STEP	LOCATION	ITEM	ACTION	REMARKS
DRAINING AND REFILLING				
1	Engine oil pan	Drain plug	a. Remove b. Install	Drain oil into 4-gallon container Tighten securely

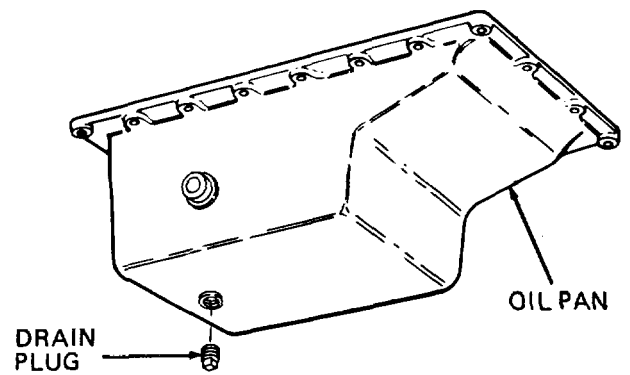

TA236106

2-12. ENGINE MAINTENANCE (CONT)

b. Draining and Refilling Engine Crankcase (cont).

STEP	LOCATION	ITEM	ACTION	REMARKS
DRAINING AND REFILLING (cont)				
2	Engine, right side	a. Engine oil level dipstick	Remove	
		b. Engine oil filler cap	Remove	Unscrew T-handle counter-clockwise; then pull out

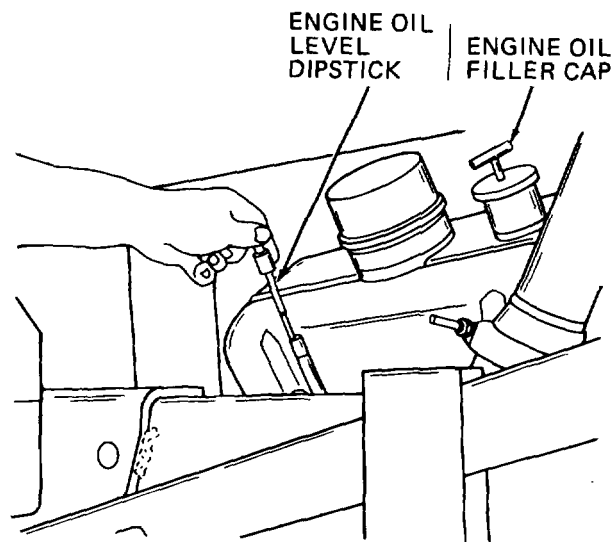

TA236107

NOTE

Do not refill crankcase without changing engine oil filters. Change engine oil filter and external oil filter pack as described in paragraphs 2-12c and 2-12d before proceeding.

c. Engine oil filler	Fill	With engine oil (refer to current lubrication order)
d. Engine oil level dipstick	Install, remove, and check	Oil shall be between add and full marks on dipstick
e. Engine oil filler cap	Install and tighten	Push onto engine oil filler; then turn T-handle clockwise until tight

2-12. ENGINE MAINTENANCE (CONT)
--

b. Draining and Refilling Engine Crankcase (cont).

STEP	LOCATION	ITEM	ACTION	REMARKS
DRAINING AND REFILLING (cont)				
3	Instrument panel	Key switch	a. Turn on b. Turn off	Start engine and run for several minutes to warm oil Press engine stop button to stop engine
4	Engine oil pan	Drain plug	Check	For oil leaks. Tighten as necessary
5	Engine, right side	Engine oil level dipstick	a. Install, remove, and check b. Install	Oil shall be between add and full marks on dipstick

2-12. ENGINE MAINTENANCE (CONT)

c. Engine-Mounted Oil Filter. This task covers oil filter replacement.

INITIAL SETUP:

Tools

No. 1 Common Organizational Maintenance Tool Kit
 Open end wrench, adjustable
 Strap type oil filter wrench

References

LO 9-2320-285-12
 (M878A1 Lubrication Order)

Equipment Condition

Paragraph	Condition Description
	Vehicle parked on level surface, engine warm and turned off, and parking brake applied.
	Cab tilted 45 degrees.
2-12b	Engine crankcase drained.

Materials/Parts

Engine oil Item 24, Appendix C
 Oil filter FSCM 72582 PN 25010495

Personnel Required

Wheel Vehicle Mechanic MOS 63B

STEP	LOCATION	ITEM	ACTION	REMARKS
------	----------	------	--------	---------

REPLACEMENT

1	Engine, rear left side	Oil filter	a. Remove b. Install	Use filter wrench; turn counterclockwise to remove Apply thin coat of clean oil to gasket of new oil filter. Install until gasket contacts base, then turn 1/2 to 3/4 of turn to obtain proper seal
---	------------------------	------------	-------------------------	--

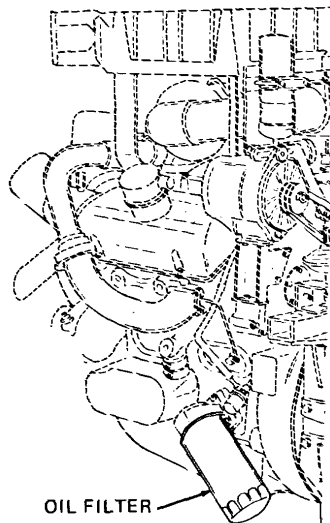

TA236116

2-12. ENGINE MAINTENANCE (CONT)

c. Engine-Mounted Oil Filter (cont).

STEP	LOCATION	ITEM	ACTION	REMARKS
------	----------	------	--------	---------

REPLACEMENT (cont)

2	Engine oil pan	Drain plug	Install	Tighten securely
---	----------------	------------	---------	------------------

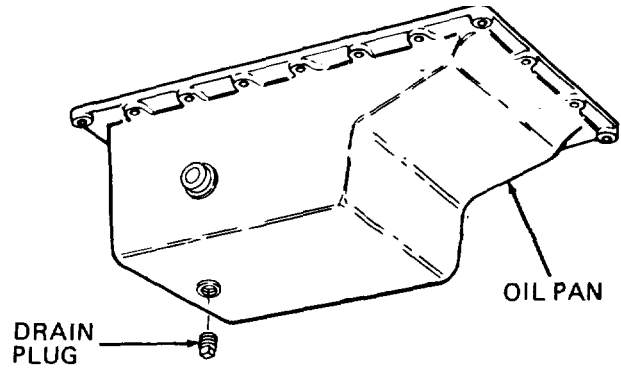

TA236106

3	Engine, right side	a. Engine oil level dipstick	Remove	
---	--------------------	------------------------------	--------	--

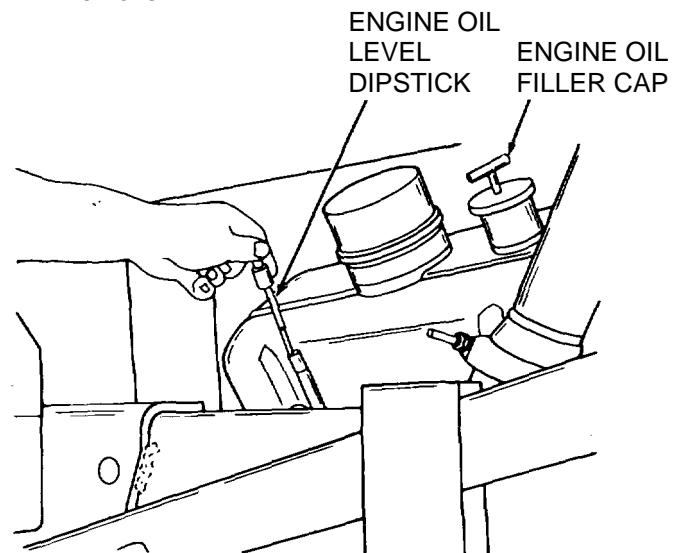

TA236107

b. Engine oil filler cap	Remove	Unscrew T-handle counter-clockwise; then pull out
c. Engine oil filler	Fill	With engine oil (refer to current lubrication order)
d. Engine oil level dipstick	Install, remove, and check	Oil shall be between add and full marks on dipstick

2-12. ENGINE MAINTENANCE (CONT)
--

c. Engine-Mounted Oil Filter (cont).

STEP	LOCATION	ITEM	ACTION	REMARKS
REPLACEMENT (cont)				
3 (cont)		e. Engine oil filler cap	Install and tighten	Push onto engine oil filler; then turn T-handle clock- wise until tight
4	Instrument panel	Key switch	a. Turn on b. Turn off	Start engine and run for several minutes to warm oil Press engine stop button to stop engine
5	Engine, left side, rear	Oil filter	Check	For oil leaks. Tighten as necessary
6	Engine, right side	Engine oil level dipstick	a. Install, remove, and check b. Install	Oil shall be between add and full marks on dipstick

2-12. ENGINE MAINTENANCE (CONT)

d. External Oil Filter and Lines.

- This task covers:**
- | | |
|-----------------------|------------------------|
| a. Servicing | e. Inspection |
| b. Removal | f. Repair |
| c. Disassembly | g. Reassembly |
| d. Cleaning | h. Installation |

INITIAL SETUP:

Tools

- No. 1 Common Organizational Maintenance Tool Kit
- Combination wrench set
- Socket wrench set
- Fine tooth hacksaw
- Machinist's vise
- Scratch wire brush
- Machinist's steel rule
- Mandrel assembly tool FSCM 00624 PN 1582-8

Materials/Parts

- Cleaning solvent Item 1, Appendix C
- Clean cloths Item 2, Appendix C
- Hydraulic oil Item 22, Appendix C
- Sixteen quarts engine oil Item 24, Appendix C
- External oil filter pack FSCM 37099 PN 2095
- Cover gasket FSCM 37099 PN 2788

Personnel Required

Wheel Vehicle Mechanic MOS 63B

Equipment Condition

Paragraph	Condition Description
	Parked on level surface; parking brake applied; engine off.
	Cab tilted 45 degrees.
2-12b	Engine crankcase drained.
2-65c	Rear platform removed.

KEY

- | | | |
|-------------------|----------------------------------|-----------------------|
| 1. Drain cock | 18. Outlet tube | 34. Hose |
| 2. Washer | 19. Outlet tube nut | 35. Adapter |
| 3. Vent plug | 20. Housing | 36. Adapter |
| 4. Washer | 21. Outlet check valve assembly | 37. Elbow |
| 5. Bolts (2) | 22. Washer | 38. Adapter |
| 6. Bolts (2) | 23. Inlet check valve halves (2) | 39. Elbow |
| 7. Clamping ring | 24. Washer | 40. 90 degree adapter |
| 8. Cover | 25. Capscrews (8) | 41. Reducer bushing |
| 9. Gasket | 26. Locknuts (8) | 42. Tee |
| 10. Hold down pin | 27. Brackets (2) | 43. Locknuts (8) |
| 11. Washers (2) | 28. Bracket bands (2) | 44. Washers (8) |
| 12. Spring | 29. Connector | 45. Capscrews (8) |
| 13. Washer | 30. Connector | 46. Clamps (2) |
| 14. Washer | 31. Hose | 47. Lock washers (2) |
| 15. Stud | 32. Connector | 48. Ring |
| 16. Orifice | 33. Elbow | 49. Valve |
| 17. Oil filter | | 50. Spring |
| | | 51. Support plate |

2-12. ENGINE MAINTENANCE (CONT)

d. External Oil Filter and Lines (cont).

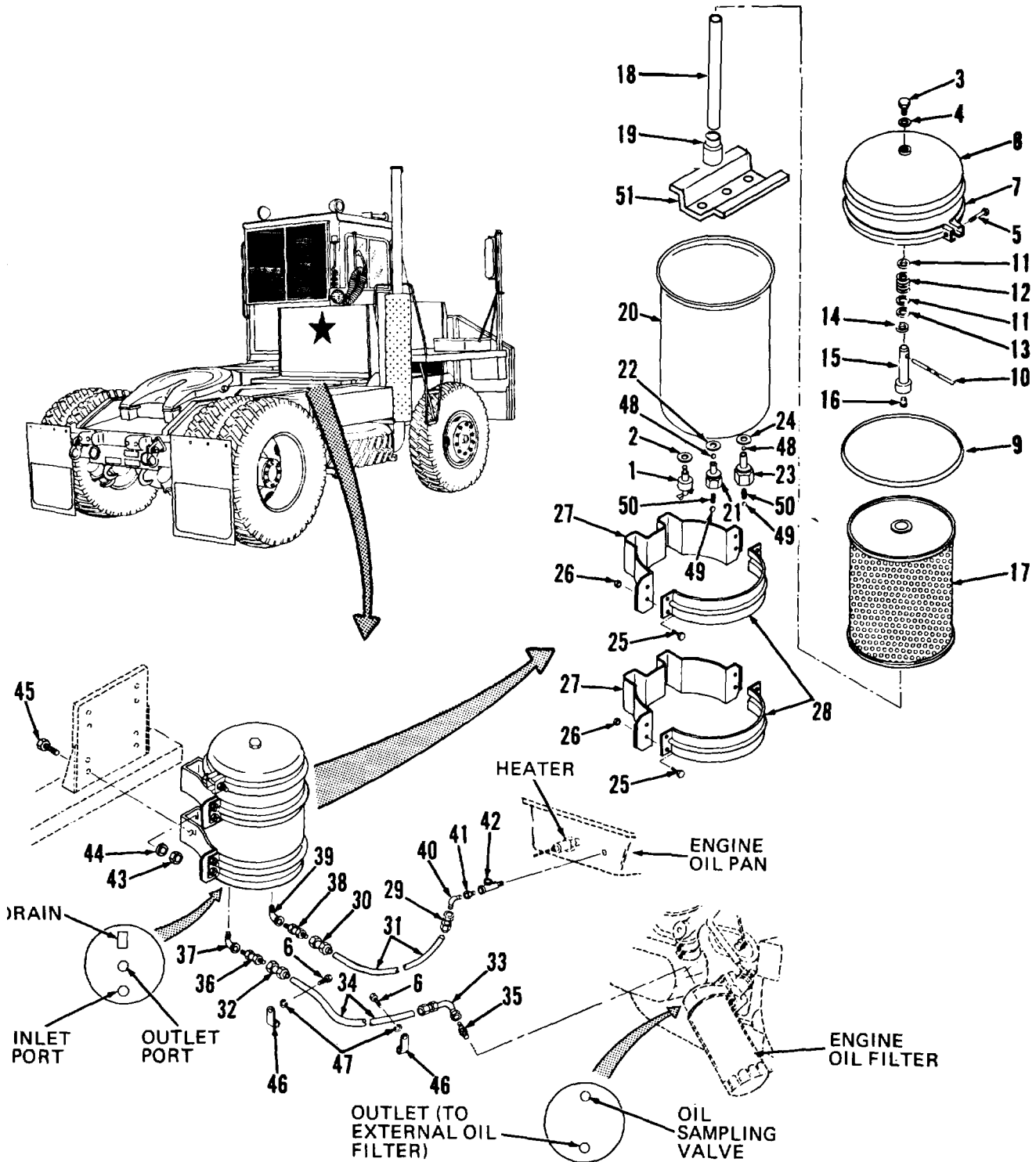

TA236117

2-12. ENGINE MAINTENANCE (CONT)

d. External Oil Filter and Lines (cont).

STEP	LOCATION	ITEM	ACTION	REMARKS
SERVICING				
1	External oil filter	a. Drain cock (1) b. Vent plug (3)	Open Loosen	Drain oil into container
2	Clamping ring (7)	Two bolts (5), clamping ring halves (7), cover (8) and gasket (9)	Remove	Discard gasket (9)
3	External oil filter	a. Stud (15) and assembled parts b. Oil filter (17) c. Housing (20) d. New oil filter (17) e. Stud (15) and assembled parts f. New gasket (9) g. Cover (8) h. Two clamping ring halves (7) and bolts (5) i. Drain cock (1)	Remove Remove Clean Install Install Install Position Install Close	Grasp hold down pin (10) and turn counterclockwise to loosen and remove stud (15) and assembled parts From housing (20); discard Use cleaning solvent P-D-680; dry using clean cloths Press down and turn clockwise until tight Apply thin coat of clean engine oil to gasket (9) Tighten bolts (5) securely Tighten securely
4	Engine oil pan	Drain plug	Install	Tighten securely

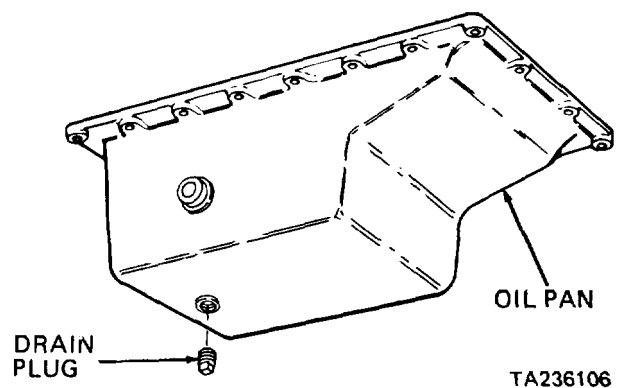

2-12. ENGINE MAINTENANCE (CONT)

d. External Oil Filter and Lines (cont).

STEP	LOCATION	ITEM	ACTION	REMARKS
------	----------	------	--------	---------

SERVICING (cont)

5	Engine, right side	a. Engine oil	Remove level dipstick	
---	--------------------	---------------	-----------------------	--

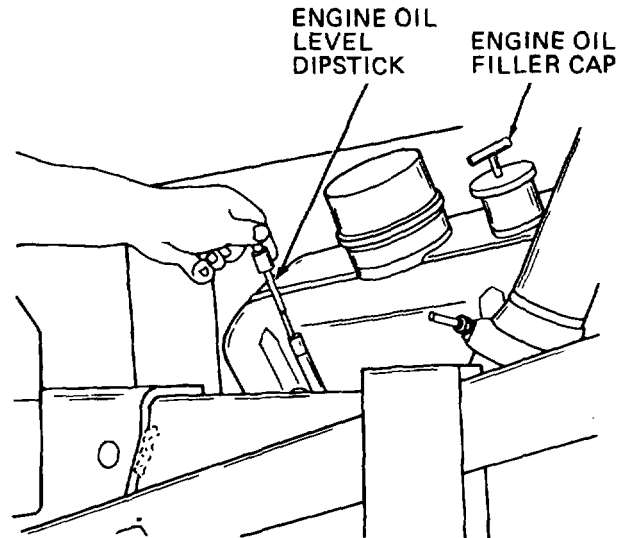

TA236107

		b. Oil filler cap	Remove	Unscrew "T" handle and pull straight out to remove
		c. Engine oil fill	Fill with engine oil (refer to current lubrication order); crankcase takes 16 quarts. Start engine. Loosen plug (3) and allow air to escape. Tighten plug (3) after oil starts to run out. Check for oil leaks at oil pan drain plug and external oil filter cover; tighten parts if necessary	
		d. Engine oil level dipstick	Turn engine off	Install and check oil level; if necessary, add engine oil
		e. Oil filler cap	Install and tighten	

REMOVAL

6	Engine oil pan	Connector (29)	Loosen and disconnect	
---	----------------	----------------	-----------------------	--

2-12. ENGINE MAINTENANCE (CONT)
--

d. External Oil Filter and Lines (cont).

STEP	LOCATION	ITEM	ACTION	REMARKS
REMOVAL (cont)				
7	External oil filter	a. Connector (30)	a. Loosen b. Disconnect c. Remove hose (31) with connectors (29 and 30) attached	
		b. Connector (32)	a. Loosen b. Disconnect	
8	Engine oil Elbow (33) filter		a. Loosen b. Disconnect	
9	Engine bell housing, lower side	a. Two bolts (6) and lock washers (47)	Remove	Support clamps (46), and hose (34) with connector (32) and elbow (33) attached
		b. Two clamps (46)	Remove	From hose (34)
		c. Hose (34) with connector (32) and elbow (33) attached	Remove	
10	External oil filter	a. Eight locknuts (26) and cap-screws (25)	Remove	Support bracket bands (28) and housing (20)
		b. Two bracket bands (28) and housing (20)	Remove	
		c. Eight locknuts (43), cap-screws (45), and washers (44)	Remove	Support brackets (27)
		d. Two brackets (27)	Remove	
DISASSEMBLY				
11	Engine oil pan	a. Compressor oil return line and 45 degree elbow	Remove	Para 2-52e

2-12. ENGINE MAINTENANCE (CONT)
--

d. External Oil Filter and Lines (cont).

STEP	LOCATION	ITEM	ACTION	REMARKS
DISASSEMBLY (cont)				
11 (cont)		b. 90 degree adapter (40), reducer bushing (41), and tee (42)	Remove	
12	Engine oil filter	Adapter (35)	Remove	
13	External oil filter	a. Adapters (36 and 38) and elbows (37 and 39)	Remove	
		b. Two bolts (5)	Remove	
		c. Clamping ring halves (7)	Remove	
		d. Filter cover (8) and gasket (9)	Remove	Discard gasket (9)
		e. Vent plug (3) and washer (4)	Remove	
		f. Stud (15) and assembled parts	Remove remove	Turn counterclockwise to
		g. Oil filter (17)	Remove and discard	
		h. Drain cock (1) and washer (2)	Remove	
		i. Outlet check valve assembly (21) and washer (22)	Remove removing	Hold outlet tube (18) while
		j. Outlet tube (18) and outlet tube nut (19)	Remove remove	Turn counterclockwise to
		k. Inlet check valve assembly (23) and washer (24)	Remove	
		l. Support plate (51)	Remove	

2-12. ENGINE MAINTENANCE (CONT)

d. External Oil Filter and Lines (cont).

STEP	LOCATION	ITEM	ACTION	REMARKS
DISASSEMBLY (cont)				
14	Stud (15) and assembled parts	a. Orifice (16) b. Spring (12) and washer (11) c. Hold down pin (10) d. Spring (12), two washers (11), and washers (13 and 14)	Remove Compress until washer (11) is below hold down pin (10) Remove while compressing spring (12) and washer (11) Release spring then remove parts	Unscrew from stud (15)
15	Inlet check valve assembly (23)	a. Ring (48) b. Valve (49) c. Spring (50)	Remove Remove Remove	Disconnect from valve (49)

NOTE

Perform step 15 above to disassemble outlet check valve assembly (21).

CLEANING

WARNING

Dry cleaning solvent (P-D-680), used to clean parts is toxic and flammable. Wear protective goggles and gloves and use only in a well ventilated area. Avoid contact with skin, eyes, and clothes and don't breathe vapors. Do not use near open flame or excessive heat and don't smoke when using it. Failure to do so could cause serious injury. If you become dizzy while using cleaning solvent, get fresh air and medical attention immediately. If contact with skin or clothes is made, flush with large amounts of water. If contact with eyes is made, wash eyes with water and seek medical aid immediately.

16		a. All parts except hoses b. Hoses (31 and 34)	a. Clean b. Dry a. Clean b. Dry	Use cleaning solvent P-D-680 Use clean cloths Use clean cloth moistened with cleaning solvent P-D-680 Use clean cloths
----	--	---	--	---

2-12. ENGINE MAINTENANCE (CONT)

d. External Oil Filter and Lines (cont).

STEP	LOCATION	ITEM	ACTION	REMARKS
INSPECTION				
17		a. Housing (20)	Inspect for: dents cracks splits damaged ports	Replace if defects observed
		b. Hoses (31 and 34)	Inspect for: cracks splits wear	Replace if defects observed. Refer to steps 18 thru 22 below
		c. Hold down pin (10)	Inspect for: cracks bent condition	Replace if defects observed
		d. Springs (12 and 50)	Inspect for: damage permanent set cracks	Replace if defects observed
		e. Remaining parts	Inspect for: cracks distortion damaged threads	Replace if defects observed. Refer to steps 18 thru 22 below for replacement of connectors (29, 30, and 32) and elbow (33)

REPAIR

CAUTION

If connectors (29, 30, and/or 32) and/or elbow (33) require replacement, discard hose (31 or 34). If hose is reused, oil leakage could occur causing damage to engine.

18	Hose (31)	a. Connector (29 or 30)	Place connector socket in vise as shown
		b. Mandrel assembly tool	Install in connector nipple; tighten nut of connector. Turn tool counterclockwise to remove connector nipple and nut
		c. Hose (31)	Turn hose (31) clockwise out of connector (29 or 30) socket; discard hose

2-12. ENGINE MAINTENANCE (CONT)

d. External Oil Filter and Lines (cont).

STEP	LOCATION	ITEM	ACTION	REMARKS
------	----------	------	--------	---------

REPAIR (cont)

NOTE

Repeat step 18 above to remove remaining connector (29 or 30) from hose.

19	Hose (34)	a. Connector (32)	Place connector socket in vise as shown
		b. Mandrel assembly tool	Install in connector nipple; tighten nut of connector. Turn tool counterclockwise to remove connector nipple and nut
		c. Hose (34)	Turn hose (34) clockwise out of connector (32) socket
		d. Elbow (33)	Place elbow (33) socket in vise. Turn elbow counterclockwise to remove nipple and nut from elbow socket
		e. Hose (34)	Turn hose clockwise out of elbow (33) socket; discard hose

WARNING

Dry cleaning solvent (P-D-680), used to clean parts is toxic and flammable. Wear protective goggles and gloves and use only in a well ventilated area. Avoid contact with skin, eyes, and clothes and don't breathe vapors. Do not use near open flame or excessive heat and don't smoke when using it. Failure to do so could cause serious injury. If you become dizzy while using cleaning solvent, get fresh air and medical attention immediately. If contact with skin or clothes is made, flush with large amounts of water. If contact with eyes is made, wash eyes with water and seek medical aid immediately.

20		Connector (29, 30, and/or 32) or elbow (33)	Clean	Use cleaning solvent P-D-680; allow to air dry. Use wire brush to remove all hose residue from socket and/or nipple of connectors or elbows
----	--	---	-------	---

2-12. ENGINE MAINTENANCE (CONT)

d. External Oil Filter and Lines (cont).

STEP	LOCATION	ITEM	ACTION	REMARKS
REPAIR (cont)				
21	Hose (31)	a. Hose (31)	Cut to proper length	Use new hose; use old hose for determining length required. Cut hose square using fine tooth hacksaw
		b. Connector (29 or 30)	Place connector socket in vise as shown	
		c. Hose (31)	Screw hose counterclockwise into socket until hose bottoms; back hose off 1/4 to 1/2 turn	
		d. Mandrel assembly tool	Oil nipple threads, mandrel assembly tool, and inside of hose liberally using hydraulic oil. Tighten connector nipple and nut on mandrel assembly tool. Apply oil to all parts	
		e. Connector (29 or 30)	Screw nipple clockwise into socket and hose. Allow 1/32 to 1/16 inch clearance between nut and socket so nut will swivel. Remove mandrel assembly tool from connector. Remove connector from vise	

NOTE

Repeat steps 21b thru 21e above to install remaining connector on hose (31).

22	Hose (34)	a. Hose (34)	Cut to proper length	Use new hose; use old hose for determining length required. Cut hose square using fine tooth hacksaw
		b. Connector (32)	Install	Perform steps 21b thru 21e above
		c. Elbow (33)	Place elbow socket in vise	
		d. Hose (34)	Screw hose (34) counterclockwise into socket until hose bottoms; back off hose 1/4 to 1/2 turn	

2-12. ENGINE MAINTENANCE (CONT)

d. External Oil Filter and Lines (cont).

STEP	LOCATION	ITEM	ACTION	REMARKS
------	----------	------	--------	---------

REPAIR (cont)

22 (cont)		e. Elbow (33) nipple and nut	Oil nipple threads and inside of hose liberally using hydraulic oil. Screw nipple clockwise into socket and hose until nut near nipple bottoms on socket. Remove hose from vise	
--------------	--	------------------------------------	---	--

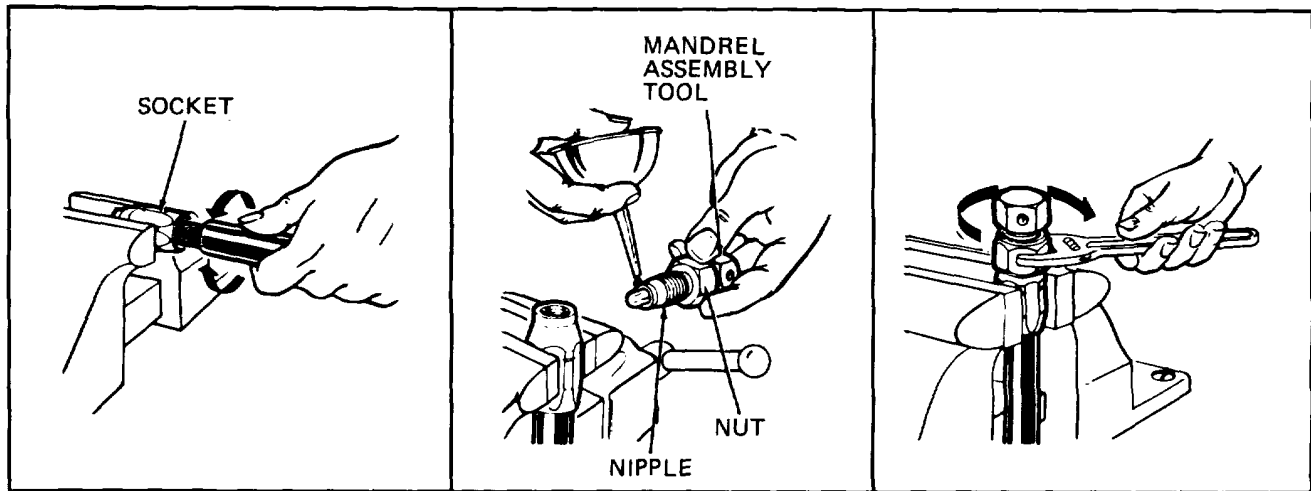

TA236149

REASSEMBLY

23	Inlet check valve assembly (23)	a. Spring (50)	Connect Install	To valve (49) In valve body
		b. Valve (49) and spring (50)		
		c. Ring (48)	Attach	To spring (50) to secure spring and valve (49) in valve body

NOTE

Repeat step 23 above to reassemble outlet check valve assembly (21).

24	Housing (20)	a. Support plate (51)	Position	Inside housing (20)
----	--------------	-----------------------	----------	---------------------

2-12. ENGINE MAINTENANCE (CONT)

d. External Oil Filter and Lines (cont).

STEP	LOCATION	ITEM	ACTION	REMARKS
REASSEMBLY (cont)				
24 (cont)		b. Washer (2), drain cock (1), washer (24), and inlet check valve assembly (23)	Install and tighten	Install through housing (20) and screw into support plate (51)
25	Outlet tube (18)	Outlet tube nut (19)	Install	On outlet tube (18)
26	Housing (20)	a. Outlet tube (18) and outlet tube nut (19)	Position	Inside housing (20)
		b. Washer (22) and outlet check valve assembly (21)	Install and tighten	Hold outlet tube (18) while tightening
(17)		c. New oil filter	Install	
27	Stud (15)	a. Washer (14)	Install	On stud (15)
		b. Washer (13)	Install	On washer (14)
		c. Washer (11)	Install	On washer (13)
		d. Spring (12)	Install	On washer (11)
		e. Washer (11)	Install and compress	Compress spring to enable installation of hold down pin (10)
		f. Hold down pin (10)	Install	Release washer (11) and spring (12)
		g. Orifice (16)	Install	If removed
28	Housing (20)	a. Stud (15) and assembled parts	Install and tighten	Into outlet tube (18); secures oil filter
		b. Gasket (9)	Install	Apply light coat of clean engine oil to gasket (9)
		c. Filter cover (8)	Install	
		d. Two clamping ring halves (7)	Position	On filter cover (8)

2-12. ENGINE MAINTENANCE (CONT)
--

d. External Oil Filter and Lines (cont).

STEP	LOCATION	ITEM	ACTION	REMARKS
REASSEMBLY (cont)				
28 (cont)		e. Two bolts (5)	Install and tighten	Secures clamping ring halvel (7) in turn securing cove] (8)
		f. Washer (4) and vent plug (3)	Install	In filter cover (8); do not tighten
		g. Elbow (39)	Install and tighten	In outlet port
		h. Elbow (37)	Install and tighten	In inlet port
		i. Adapters (36 and 38)	Install and tighten	In elbows (37 and 39)
29	Engine oil filter	Adapter (35)	Install and tighten	
30	Engine oil pan	a. Tee (42), reducer bushing (41), and 90 degree adapter (40)	Install and tighten	
		b. 45 degree elbow and compressor oil return line	Install	Para 2-52e
INSTALLATION				
31	External oil filter mounting plate	a. Two brackets (27)	Position	
		b. Eight capscrews (45), washers (44), and locknuts (43)	Install and tighten	Secures brackets (27)
		c. Housing (20)	Position and support	On brackets (27)
		d. Two bracket bands (28)	Position and support	On housing (20)
		e. Eight capscrews (25) and locknuts (26)	Install and tighten	Secures bracket bands (28) and housing (20)
32	Hose (34)	Two clamps (46)	Position	On hose (34)

2-12. ENGINE MAINTENANCE (CONT)

d. External Oil Filter and Lines (cont).

STEP	LOCATION	ITEM	ACTION	REMARKS
INSTALLATION (cont)				
33	Engine oil filter	a. Hose (34)	Route and connect	Between engine oil filter and external oil filter housing (20)
		b. Elbow (33)	Connect and tighten	To adapter (35)
34	External oil filter	Connector (32)	Connect and tighten	To adapter (36)
35	Engine bell housing, lower side	a. Two clamps (46)	Position	Clamps were installed on hose (34) in step 32 above
		b. Two lock washers (47) and capscrews (6)	Install and tighten	Secures clamps to engine bell housing
36	Engine oil pan	a. Hose (31)	Route and connect	Between engine oil pan and external oil filter housing (20)
		b. Connector (29)	Connect and tighten	To 90 degree adapter (40)
37	External oil filter	a. Connector (30)	Connect and tighten	To adapter (38)
		b. Drain cock (1)	Close tightly	
38	Engine oil pan	Drain plug	Install and tighten	

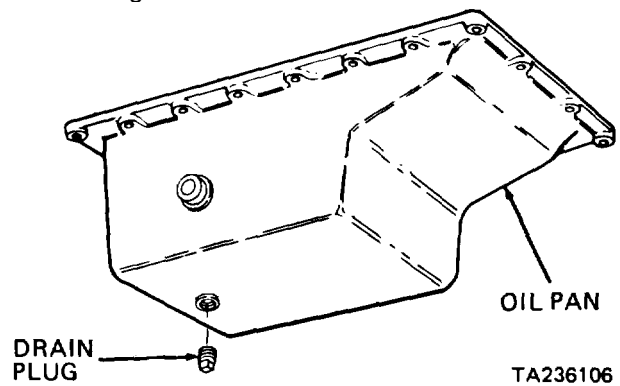

NOTE

Perform step 5 above to fill engine with oil.

39	Vehicle, rear	Rear platform	Install	Para 2-65c
----	---------------	---------------	---------	------------

2-12. ENGINE MAINTENANCE (CONT)

e. Dipstick and Tube.

This task covers:

- a. Removal
- b. Cleaning

- c. Inspection
- d. Installation

INITIAL SETUP:

Tools

No. 1 Common Organizational Maintenance Tool Kit
 Socket wrench set
 Adjustable open end wrench

References

LO 9-2320-285-12
 (M878A1 Lubrication Order)

Equipment Condition

Paragraph	Condition Description
-----------	-----------------------

Materials/Parts

Cleaning solvent	Item 1, Appendix C
Clean cloths	Item 2, Appendix C

Parked on level surface; parking brake applied; engine off.
 Cab tilted 45 degrees.
 70 ampere circuit breaker and starter solenoid removed.
 Starter removed.

Personnel Required

Wheel Vehicle Mechanic MOS 63B	2-25b
	2-25a

STEP	LOCATION	ITEM	ACTION	REMARKS
------	----------	------	--------	---------

REMOVAL

WARNING

Dry cleaning solvent (P-D-680), used to clean parts is toxic and flammable. Wear protective goggles and gloves and use only in a well ventilated area. Avoid contact with skin, eyes, and clothes and don't breathe vapors. Do not use near open flame or excessive heat and don't smoke when using it. Failure to do so could cause serious injury. If you become dizzy while using cleaning solvent, get fresh air and medical attention immediately. If contact with skin or clothes is made, flush with large amounts of water. If contact with eyes is made, wash eyes with water and seek medical aid immediately.

1	Engine, rear right side	a. Area at bottom of tube (6)	Clean	Use cleaning solvent P-D-680. Prevents intrusion of dirt into engine lubrication system
		b. Nut (2), lock washer (3), and capscrew (4)	Remove	
		c. Tube clip (5)	Remove	
		d. Tube (6)	Unscrew	From adapter (7); remove by withdrawing from bottom of engine
		e. Adapter (7)	Remove	

2-12. ENGINE MAINTENANCE (CONT)

e. Dipstick and Tube (cont).

KEY

- 1. Dipstick
- 2. Nut
- 3. Lock washer
- 4. Capscrew
- 5. Tube clip
- 6. Tube
- 7. Adapter

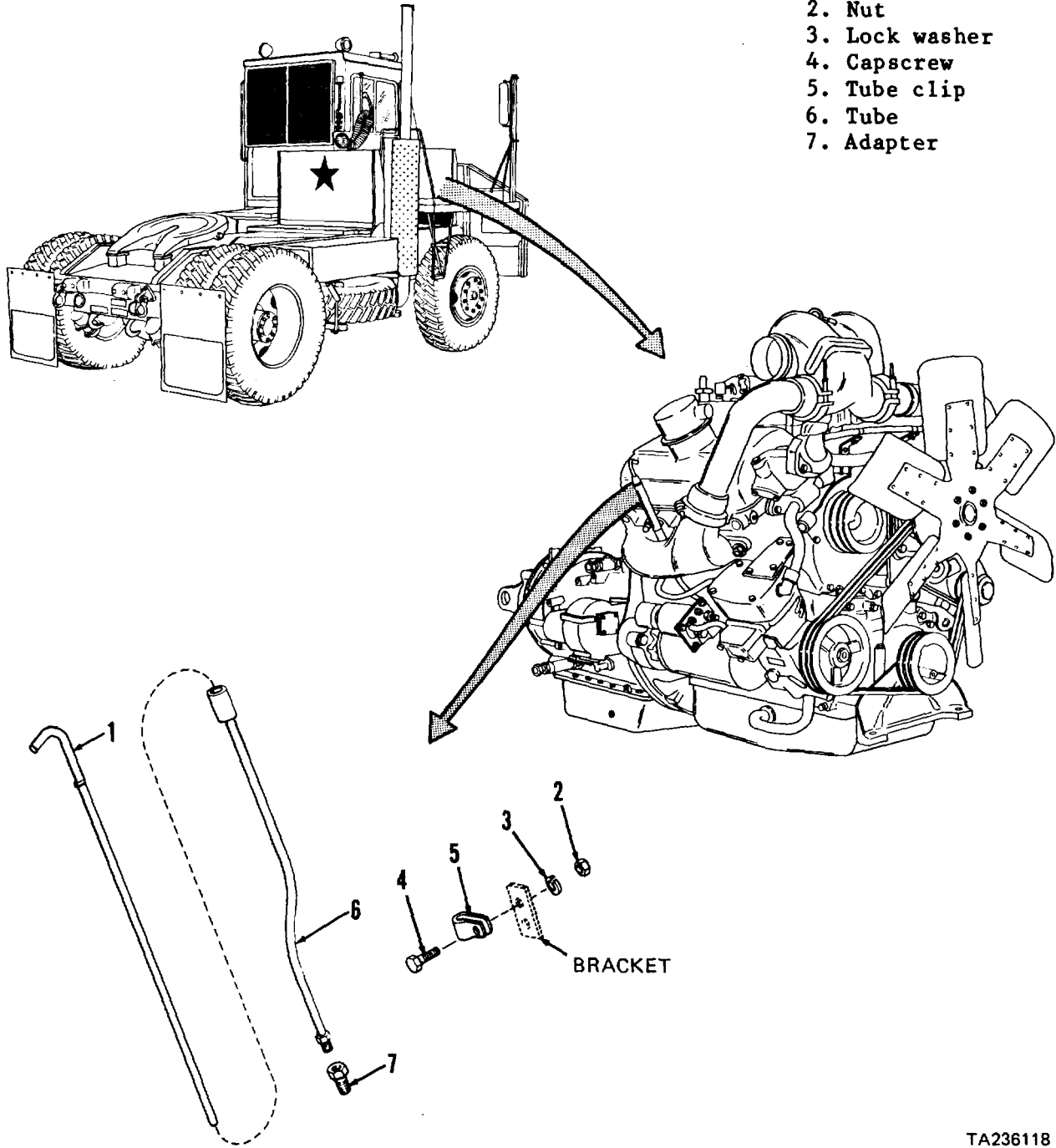

TA236118

2-12. ENGINE MAINTENANCE (CONT)

e. Dipstick and Tube (cont).

STEP	LOCATION	ITEM	ACTION	REMARKS
CLEANING				
<u>WARNING</u>				
Dry cleaning solvent (P-D-680), used to clean parts is toxic and flammable. Wear protective goggles and gloves and use only in a well ventilated area. Avoid contact with skin, eyes, and clothes and don't breathe vapors. Do not use near open flame or excessive heat and don't smoke when using it. Failure to do so could cause serious injury. If you become dizzy while using cleaning solvent, get fresh air and medical attention immediately. If contact with skin or clothes is made, flush with large amounts of water. If contact with eyes is made, wash eyes with water and seek medical aid immediately.				
2		All parts	Clean	Use cleaning solvent P-D-680; dry using clean cloths
INSPECTION				
3		All parts	Inspect for cracks damaged threads bent condition	Replace if defects observed
INSTALLATION				
4	Engine, rear, right side	a. Adapter (7) b. Tube (6) c. Tube clip (5) d. Capscrew (4), lock washer (3) and nut (2) e. Dipstick (1) f. Starter g. 70 ampere circuit breaker and solenoid	Install Install Position Install Install and check oil Install Install	If removed Screw into adapter (7) On tube (6) Secures tube clip (5) to bracket Add oil as necessary (refer to current lubrication order) Para 2-25a Para 2-25b

2-12. ENGINE MAINTENANCE (CONT)

f. Engine Oil Sampling Valve.

This task covers:

- a. Oil sampling
- b. Removal
- c. Cleaning
- d. Inspection
- e. Installation

INITIAL SETUP:

Tools

No. 1 Common Organizational Maintenance Tool Kit
 Safety glasses
 Socket wrench set
 Adjustable open end wrench

Personnel Required

Wheel Vehicle Mechanic MOS 63B

Equipment Condition

Paragraph	Condition Description
	Parked on level surface; parking brake applied; engine off.

Materials/Parts

Cleaning solvent	Item 1, Appendix C
Clean cloths	Item 2, Appendix C
Engine oil	Item 24, Appendix C

STEP	LOCATION	ITEM	ACTION	REMARKS
------	----------	------	--------	---------

OIL SAMPLING

1	Engine, left side	a. Engine	Warm up	Idle engine to obtain normal operating temperature Under hose (5) Open valve (12) and drain one pint of oil into container; then close valve and remove container
		b. Container	Position	
		c. Hose (5)	Flush	

NOTE

Procure clean sample bottle and a copy of DD Form 2026 (Oil Analysis Request) in accordance with local procedure.

d. Clean sample bottle	a. Open	Remove bottle cap and place on clean surface with edges up
	b. Position	Under hose (5)
	c. Fill	Open valve (12) and fill sample bottle to within 1/2 inch of top
	d. Close	Install and tighten cap; wipe oil from exterior
e. Engine	e. Package Shut down	Place bottle in plastic bag

2-12. ENGINE MAINTENANCE (CONT)

f. Engine Oil Sampling Valve (cont).

KEY

- 1. Elbow
- 2. Fitting
- 3. Hose
- 4. Fitting
- 5. Hose
- 6. Fitting
- 7. Capscrews (2)
- 8. Lock washers (2)
- 9. Bracket
- 10. Pipe plug
- 11. Nut
- 12. Sampling valve

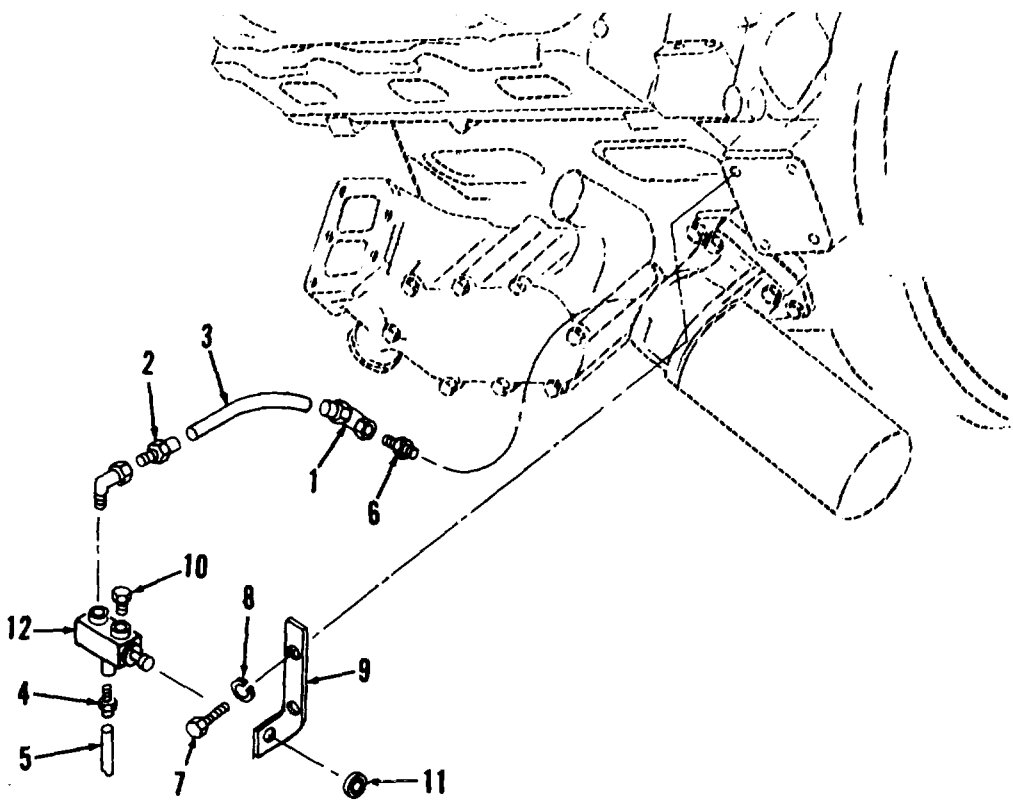
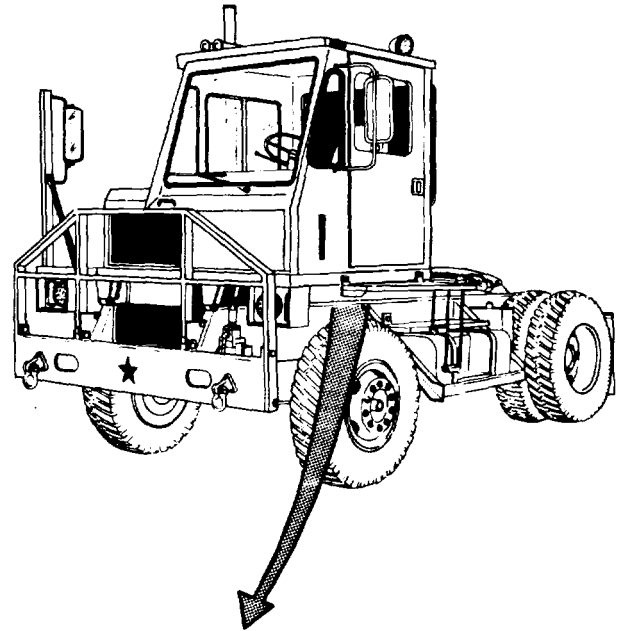

TA236394

2-12. ENGINE MAINTENANCE (CONT)

f. Engine Oil Sampling Valve (cont).

STEP	LOCATION	ITEM	ACTION	REMARKS
OIL SAMPLING (cont)				
2	Office	a. DD Form 2026	Fill out	Place plastic bag with oil sample and completed DD Form 2026 in shipping sack
		b. Oil sample	a. Package	
			b. Ship	On same day sample is taken. Ship according to local procedure

NOTE

Special oil samples will be clearly marked "SPECIAL" and banded with red tape for easy identification at the analysis laboratory.

REMOVAL

3	Engine, left side	a. Elbow (1)	Disconnect	From fitting (6)
		b. Fitting (2)	Disconnect	From sampling valve (12)
		c. Hose (3)	Remove	
		d. Fitting (4)	Disconnect	From sampling valve (12)
		e. Hose (5)	Remove	
		f. Fitting (6)	Remove	From engine oil filter housing
4	Sampling valve (12)	a. Two capscrews (7) and lock washers (8)	Remove	Support bracket (9)
		b. Bracket (9) with sampling valve (12)	Remove	From engine crankcase
		c. Pipe plug (10)	Remove	
		d. Nut (11)	Remove	
		e. Sampling valve (12)	Remove	Pull from bracket (9)

CLEANING

5		a. Hoses (3 and 5)	Clean	Wipe with clean, dry cloth
---	--	--------------------	-------	----------------------------

2-12. ENGINE MAINTENANCE (CONT)

f. Engine Oil Sampling Valve (cont).

STEP	LOCATION	ITEM	ACTION	REMARKS
------	----------	------	--------	---------

CLEANING (cont)

5
(cont)

WARNING

Dry cleaning solvent (P-D-680), used to clean parts is toxic and flammable. Wear protective goggles and gloves and use only in a well ventilated area. Avoid contact with skin, eyes, and clothes and don't breathe vapors. Do not use near open flame or excessive heat and don't smoke when using it. Failure to do so could cause serious injury. If you become dizzy while using cleaning solvent, get fresh air and medical attention immediately. If contact with skin or clothes is made, flush with large amounts of water. If contact with eyes is made, wash eyes with water and seek medical aid immediately.

b. All other parts	Clean	Use cleaning solvent P-D-680; dry with clean cloths
--------------------	-------	---

INSPECTION

6

a. Hoses (3 and 5)	Inspect	Replace if cracked, cut, frayed, deteriorated, or otherwise damaged
b. Sampling valve (12)	Inspect	Replace if cracked, valve inoperative, or evidence of leakage observed
c. All other parts	Inspect	Replace if cracked, broken, or threads damaged

INSTALLATION

7 Sampling valve (12)

a. Sampling valve (12)	Position	In bracket (9)
b. Nut (11)	Install and tighten	Secures valve (12) to bracket (9)
c. Plug (10)	Install and tighten	
d. Bracket (9)	Position	On engine crankcase with sampling valve (12)
e. Two capscrews (7) and lock washers (8)	Install and tighten	Secures bracket (9) to engine

2-12. ENGINE MAINTENANCE (CONT)

f. Engine Oil Sampling Valve (cont).

STEP	LOCATION	ITEM	ACTION	REMARKS
INSTALLATION (cont)				
8	Engine, left side	a. Hose (5) b. Fitting (4) c. Fitting (6) d. Hose (3) e. Fitting (2) f. Elbow (1)	Install Tighten Install and tighten Install Connect and tighten Connect and tighten	In engine oil filter housing To sampling valve (12) To fitting (6)
9	Instrument panel	Key switch	a. Turn on b. Turn off	Start engine and run for several minutes to warm oil Press engine stop button to stop engine
10	Engine, left side	Sampling valve, hoses, and fittings	Check	For oil leaks. Tighten fittings or replace parts as necessary
11	Engine, right side	Engine oil level	Check; fill as necessary	Para 2-12c

2-13. FUEL SYSTEM MAINTENANCE

a. Air Cleaner Assembly and Restriction Indicator.

This task covers: a. Servicing d. Inspection
 b. Disassembly e. Reassembly
 c. Cleaning

INITIAL SETUP

Tools

No. 1 Common Organizational Maintenance
 Tool Kit

- Combination wrench set
- Socket wrench set
- Screwdriver
- Safety glasses

Materials/Parts

Cleaning solvent Item 1, Appendix C
 Clean cloths Item 2, Appendix C 2-13d
 Engine oil Item 24, Appendix C
 Detergent Item 27, Appendix C
 Air cleaner element FSCM 21585 PN C45800

Personnel Required

Wheel Vehicle Mechanic MOS 63B

Equipment Condition

Paragraph	Condition Description
-----------	-----------------------

Vehicle parked on level surface, engine off, and parking brake applied.
 Cab tilted 45 degrees.
 Quick start cylinder removed.

KEY

- | | |
|--------------------------|-------------------------|
| 1 Capscrews (4) | 26 Bracket |
| 2 Nuts (4) | 27 Brackets (2) |
| 3 Clamp straps (2) | 28 Capscrews (5) |
| 4 Air cleaner element | 29 Locknuts (5) |
| 5 Capscrews (2) | 30 Washers (5) |
| 6 Nuts (2) | 31 Plenum |
| 7 Bracket | 32 Capscrew |
| 8 Precleaner | 33 Lock washer |
| 9 Vacuator valve | 34 Left rear bracket |
| 10 Hose | 35 Capscrews (2) |
| 11 Elbow | 36 Lock washers (2) |
| 12 Clamps (4) | 37 Left front bracket |
| 13 Elbow | 38 Capscrews (3) |
| 14 Nuts (2) | 39 Lock washers (3) |
| 15 Washers (2) | 40 Washers (3) |
| 16 U-bolt | 41 Right rear bracket |
| 17 Clamp | 42 Elbow |
| 18 Intake tube | 43 Nut |
| 19 Nut | 44 Lock washer |
| 20 Capscrew | 45 Clamp |
| 21 Bracket | 46 Tie straps (11) |
| 22 Elbow | 47 Indicator body |
| 23 Capscrews (8) | 48 Nut |
| 24 Nuts (8) | 49 Lock washer |
| 25 Bracket | 50 Adapter |

2-13. FUEL SYSTEM MAINTENANCE (CONT)

a. Air Cleaner Assembly and Restriction Indicator.

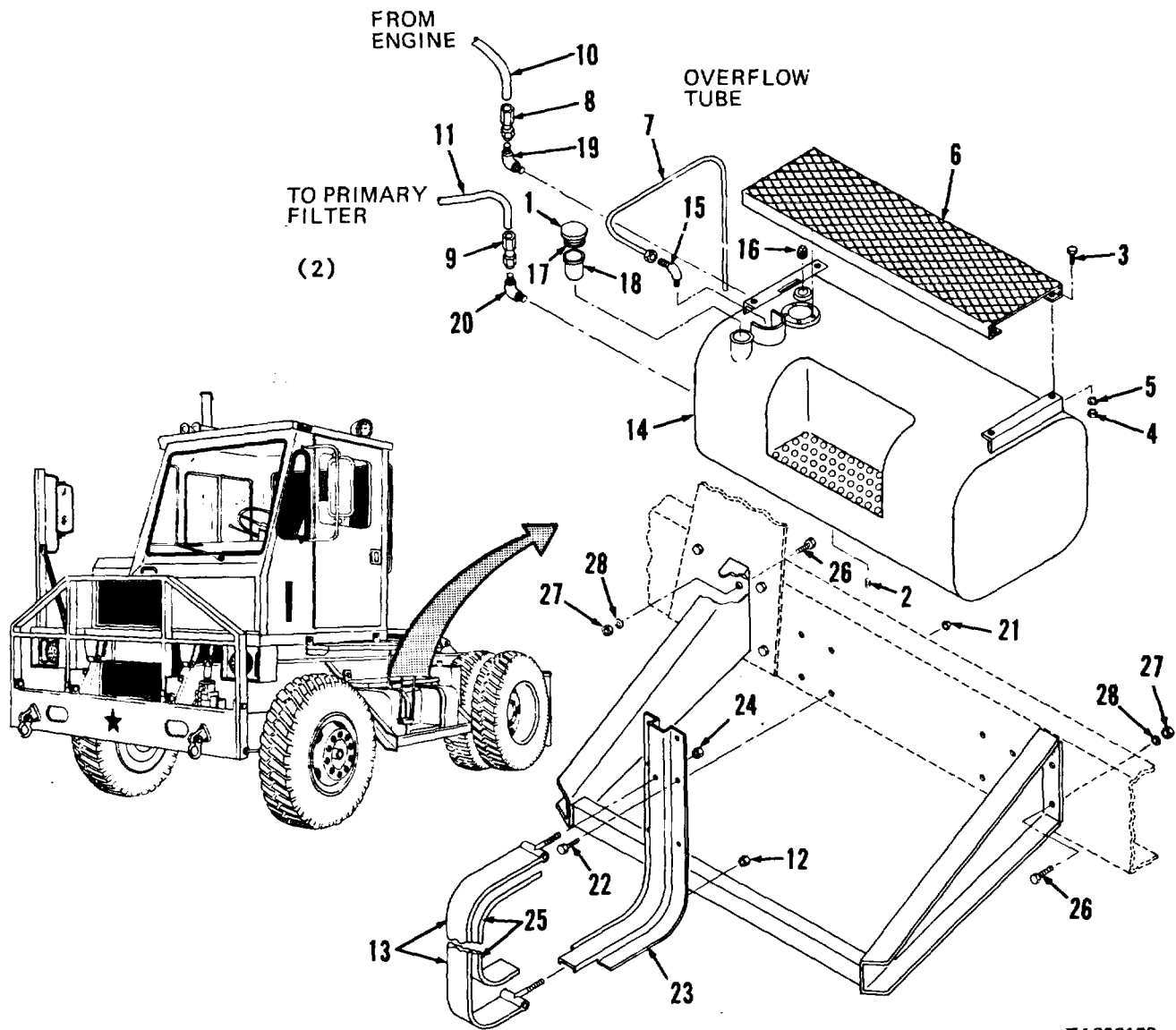

TA236122

2-13. FUEL SYSTEM MAINTENANCE (CONT)

- a. Air Cleaner Assembly and Restriction Indicator.

STEP	LOCATION	ITEM	ACTION	REMARKS
SERVICING				
1	Air cleaner element (4)	a. Four capscrews (1) and nuts (2)	Remove	
		b. Two clamp straps (3)	Remove	
		c. Air cleaner element (4)	Remove and discard	
2	Precleaner (8)	a. Two capscrews (5) and nuts (6)	Remove	Support precleaner (8) and bracket (7)
		b. Bracket (7) and precleaner (8)	Remove and separate	
		c. Vacuator valve (9)	Remove	Pull from precleaner (8)

WARNING

Compressed air must not exceed 30 psi. Wear safety glasses when drying parts with compressed air. Failure to do so could cause serious injury to eyes and possible blindness. If you hurt your eyes or if a foreign object is blown into your eyes, seek medical attention immediately.

3	Air cleaner element (4)	d. Precleaner (8) vacuator valve (9), and element (4)	Clean	Turn vacuator valve inside out and clean with mild solution of detergent and water; dry using compressed air
		a. Air cleaner element (4)	Position	Install new element every third service interval
		b. Two clamp straps (3)	Position	Over air cleaner element (4)
4	Precleaner (8)	c. Four capscrews (1) and nuts (2)	Install and tighten	
		a. Vacuator valve (9)	Install	Push onto precleaner (8); position rubber seal parallel to front of precleaner
		b. Bracket (7)	Position	Over precleaner (8)

2-13. FUEL SYSTEM MAINTENANCE (CONT)**a. Air Cleaner Assembly and Restriction Indicator.**

STEP	LOCATION	ITEM	ACTION	REMARKS
SERVICING (cont)				
4 (cont)		c. Precleaner (8) with bracket (7)	Position	On air cleaner
		d. Two capscrews (5) and nuts (6)	Install and tighten	
DISASSEMBLY				
5	Air cleaner	Air cleaner element (4) and precleaner (8)	Remove	As outlined in steps 1 and 2 above
6	Intake tube (18)	a. Hose (10) b. Elbow (11) c. Four clamps (12) d. Elbow (13) e. Two clamps (12) f. Two nuts (14), washers (15), U-bolt (16), clamp (17), and intake tube (18) g. Nut (19), cap-screw (20), and bracket (21) h. Elbow (22) i. Two clamps (12)	Disconnect Remove Loosen Remove Remove Remove Remove Remove Remove	From elbow (11) From intake tube (18) From turbocharger inlet Slide from elbow (13) Slide from elbow (22)
7	Plenum (31)	a. Eight capscrews (23) and nuts (24) b. Brackets (25 and 27) c. Quick start bracket d. Two capscrews (28), lock-nuts (29), and washers (30)	Remove Remove Remove Remove	Support brackets (25 and 27) Para 2-13d; set aside with associated parts on engine From left front bracket (37) while supporting bracket (26)

2-13. FUEL SYSTEM MAINTENANCE (CONT)

- a. Air Cleaner Assembly and Restriction Indicator.

STEP	LOCATION	ITEM	ACTION	REMARKS
DISASSEMBLY (cont)				
7 (cont)		e. Bracket (26)	Remove	
		f. Three capscrews (28), lock-nuts (29), and washers (30)	Remove	
		g. Plenum (31)	Remove	
8	Brackets (34, 37, and 41)	a. Capscrew (32) and lock washer (33)	Remove	Support left rear bracket (34)
		b. Left rear bracket (34)	Remove	Lift from engine
		c. Fan clutch control solenoid	Remove	Para 2-15e; set aside on engine
		d. Two capscrews (35) and lock washers (36)	Remove	Support left front bracket (37)
		e. Left front bracket (37)	Remove	Lift from engine
9	Radiator and engine	Drain cocks	Open	Drain coolant; para 2-15b(1)
10	Engine, right rear, top	a. Three capscrews (38), lock washers (39), and washers (40)	Remove	Support right rear bracket (41)
		b. Right rear bracket (41)	Remove	
11	Cab, underside and engine, front	a. Hose (10)	Disconnect	From elbow (42)
		b. Elbow (42)	Remove	From adapter (50)
		c. Nut (43), lock washer (44), and clamp (45)	Remove	
		d. 11 tie straps (46)	Cut and remove	Note locations to aid reassembly
		e. Hose (10)	Remove	Remove from tractor
12	Cab tilt pump	Cab	Lower	To normal operating position

2-13. FUEL SYSTEM MAINTENANCE (CONT)

- a. Air Cleaner Assembly and Restriction Indicator.

STEP	LOCATION	ITEM	ACTION	REMARKS
DISASSEMBLY (cont)				
13	Tractor	Engine hood	Open	
14	Right instrument panel	a. Indicator body (47)	Remove	From adapter (50); turn counterclockwise to remove
		b. Nut (48), lock washer (49), and adapter (50)	Remove	
CLEANING				
15		a. Elbows (13 and 22) and hose (10)	Clean	Wipe with clean, dry cloth only

WARNING

Dry cleaning solvent (P-D-680), used to clean parts is toxic and flammable. Wear protective goggles and gloves and use only in a well ventilated area. Avoid contact with skin, eyes, and clothes and don't breathe vapors. Do not use near open flame or excessive heat and don't smoke when using it. Failure to do so could cause serious injury. If you become dizzy while using cleaning solvent, get fresh air and medical attention immediately. If contact with skin or clothes is made, flush with large amounts of water. If contact with eyes is made, wash eyes with water and seek medical aid immediately.

Compressed air must not exceed 30 psi. Wear safety glasses when drying parts with compressed air. Failure to do so could cause serious injury to eyes and possible blindness. If you hurt your eyes or if a foreign object is blown into your eyes, seek medical attention immediately.

- b. All metal parts
 - a. Clean Use cleaning solvent P-D-680; dry using compressed air
 - b. Lubricate Apply thin coat of engine oil after parts are dry

2-13. FUEL SYSTEM MAINTENANCE (CONT)

- a. Air Cleaner Assembly and Restriction Indicator.

STEP	LOCATION	ITEM	ACTION	REMARKS
INSPECTION				
16		a. Hose (10)	Inspect	Apply compressed air at 10 psi, check for blockage. Replace hose if blocked, cracked, or deteriorated
		b. Elbows (13 and 22) and in-take tube (18)	Inspect	Replace if bent, cut, cracked or otherwise damaged
		c. Vacuator valve (9)	Inspect	Lip seals of valve should be open, forming a wedge-shaped cone. If valve lips are inverted, check for blockage at air cleaner inlet. Replace valve if defective or deteriorated
		d. All other parts	Inspect	Replace if cracked, bent, or threads damaged
REASSEMBLY				
17	Cab tilt pump	Cab	Tilt 45 degrees	
18	Brackets (34, 37, and 41)	a. Left front bracket (37)	Position	On engine; align mounting holes
		b. Two capscrews (35) and lock washers (36)	Install and tighten	
		c. Fan clutch control solenoid	Install	Para 2-15e
		d. Right rear bracket (41)	Position	On engine; align mounting holes
		e. Three washers (40), lock washers (39), and capscrews (38)	Install and tighten	
		f. Left rear bracket (34)	Position	On engine; align mounting holes
		g. Lock washer (33) and capscrew (32)	Install and tighten	

2-13. FUEL SYSTEM MAINTENANCE (CONT)

a. Air Cleaner Assembly and Restriction Indicator.

STEP	LOCATION	ITEM	ACTION	REMARKS
REASSEMBLY (cont)				
19	Plenum (31)	a. Plenum (31)	Position	
		b. Three capscrews (28), washers (30), and locknuts (29)	Install and tighten	On rear brackets (34 and 41) only
		c. Bracket (26)	Position	On plenum (31)
		d. Two capscrews (28), washers (30), and locknuts (29)	Install	Through brackets (37 and 26) and plenum (31); do not tighten
		e. Bracket (25)	Position	On plenum (31) rear; align with 5th and 8th holes from right hand side
		f. Two capscrews (23) and nuts (24)	Install and tighten	Secures bracket (25)
		g. Two brackets (27)	Position	On plenum (31) right and left hand sides, align with 2nd and 3rd holes from rear
		h. Four capscrews (23) and nuts (24)	Install and tighten	Secures brackets (27)
		i. Two capscrews (23) and nuts (24)	Install tighten	On bracket (26); do not
20	Intake tube (18)	a. Elbow (22) and clamp (12)	Connect and tighten	To bottom of plenum (31)
		b. Bracket (21)	Position	On plenum (31) rear; align with 7th hole from right hand side
		c. Capscrew (20) and nut (19)	Install and tighten	Secures bracket (21)
		d. Clamp (17), U-bolt (16), two washers (15), and nuts (14)	Install	On bracket (21); do not tighten
		e. Clamp (12)	Position	Slide onto elbow (22); do not tighten
		f. Intake tube (18)	a. Position	Through U-bolt (16)
		g. Clamp (12)	b. Connect Tighten	To elbow (22) Secures tube (18) to elbow (22)

2-13. FUEL SYSTEM MAINTENANCE (CONT)

- a. Air Cleaner Assembly and Restriction Indicator.

STEP	LOCATION	ITEM	ACTION	REMARKS
REASSEMBLY (cont)				
20 (cont)		h. Two nuts (14) i. Elbow (13) and two clamps (12) j. Elbow (11) k. Hose (10) l. 11 new tie straps (46) m. Clamp (45) n. Lock washer (44) and nut (43)	Tighten Install and tighten Install a. Connect b. Route Install Position Install and tighten	On intake tube (18) and turbocharger inlet On intake tube (18) To elbow (11) To right instrument panel At locations noted during disassembly Secures clamp (45)
21	Plenum (31)	Quick start bracket and cylinder	Install	Para 2-13d
22	Air cleaner	a. Air cleaner element (4) b. Bracket (26) c. Two nuts (24), two locknuts (29), and four nuts (2) d. Precleaner (8)	Install Position Tighten Install	As outlined in step 3 above; do not tighten nuts (2) Against rubber seal on air cleaner element (4) Secures air cleaner element (4) to plenum (31) As outlined in step 4 above
23	Radiator and engine	a. Drain cocks b. Radiator	Close Fill	Para 2-15b(1) Para 2-15a(1)
24	Cab tilt pump	Cab	Lower	To normal operating position
25	Right instrument panel	a. Adapter (50) b. Lock washer (49) and nut (48) c. Indicator body (47) d. Elbow (42) e. Hose (10)	Install Install and tighten Install Install Connect	In instrument panel In adapter (50); turn clockwise In adapter (50) To elbow (42)
26	Tractor	Engine hood	Close and secure	

2-13. FUEL SYSTEM MAINTENANCE (CONT)

b. Fuel Tank, Lines and Fittings.

(1) Fuel Tank.

- This task covers:
- | | |
|----------------|----------------------|
| a. Draining | e. Inspection/Repair |
| b. Removal | f. Reassembly |
| c. Disassembly | g. Installation |
| d. Cleaning | h. Filling |

INITIAL SETUP

Tools

No. 1 Common Organizational Maintenance
 Tool Kit
 Adjustable open end wrench
 Socket wrench set

References

LO 9-2320-285-12
 (M878A1 Lubrication Order)

Equipment Condition

Paragraph	Condition Description
-----------	-----------------------

Materials/Parts

Cleaning solvent	Item 1, Appendix C
Clean cloths	Item 2, Appendix C

Personnel Required

Two Wheel Vehicle Mechanics MOS 63B

Parked on level surface;
 parking brake applied; engine
 off.
 Cab tilted 45 degrees.

STEP	LOCATION	ITEM	ACTION	REMARKS
------	----------	------	--------	---------

DRAINING

1	Left side of tractor	Filler cap (1)	Remove	
---	----------------------	----------------	--------	--

WARNING

Diesel fuel is highly combustible. When performing the following step, do not smoke or allow open flames or sparks into the area. Death or severe injury may result if personnel fail to observe this precaution. If you are burned, obtain medical attention immediately.

2	Fuel tank (14) bottom	a. Container b. Drain plug (2)	Position Remove	Under drain plug Drain fuel into 50 gallon container
---	-----------------------	-----------------------------------	--------------------	---

2-13. FUEL SYSTEM MAINTENANCE (CONT)

b. Fuel Tank, Lines and Fittings.

(1) Fuel Tank (cont).

KEY

- 1. Filler cap
- 2. Drain plug
- 3. Capscrews (4)
- 4. Nuts (4)
- 5. Lock washers (4)
- 6. Platform
- 7. Tube
- 8. Swivel connector
- 9. Swivel connector
- 10. Hose assembly
- 11. Hose assembly
- 12. Nuts (2)
- 13. Strap assemblies (2)
- 14. Fuel tank
- 15. Fitting
- 16. Pipe plug

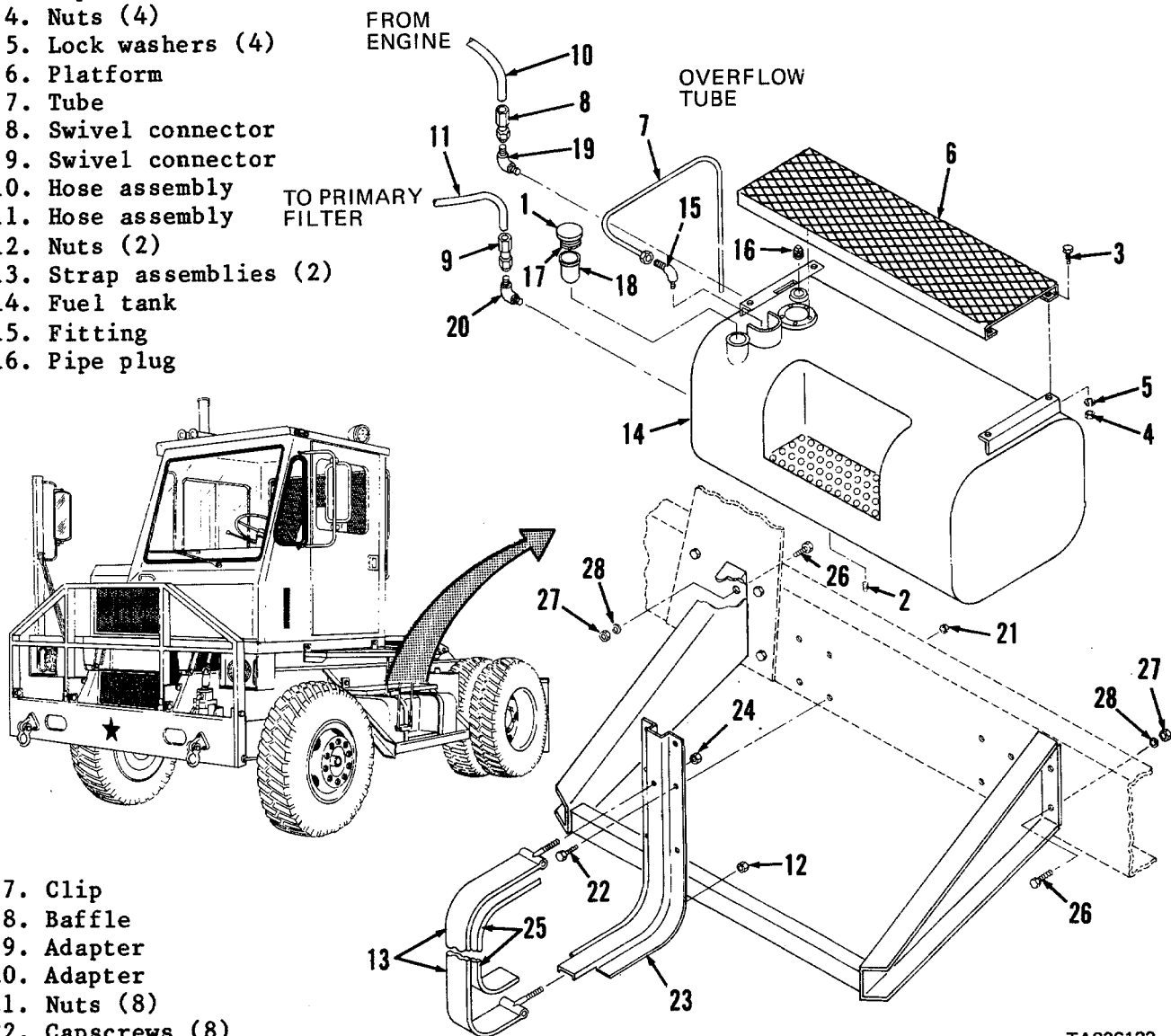

- 17. Clip
- 18. Baffle
- 19. Adapter
- 20. Adapter
- 21. Nuts (8)
- 22. Capscrews (8)
- 23. Fuel tank brackets (2)
- 24. Nuts (2)
- 25. Skid strips (2)
- 26. Capscrews (4)
- 27. Nuts (4)
- 28. Washers (4)
- 29. Fuel tank guard

TA236122

2-13. FUEL SYSTEM MAINTENANCE (CONT)

b. Fuel Tank, Lines and Fittings.

(1) Fuel Tank (cont).

STEP	LOCATION	ITEM	ACTION	REMARKS
REMOVAL				
3	Fuel tank (14), top	a. Four capscrews (3), nuts (4) and lock-washers (5)	Remove	
		b. Platform (6)	Remove	Lift from fuel tank (14)
		c. Fuel sender	Remove	Para 2-32b
		d. Tube (7)	Disconnect and remove	
4	Fuel tank (14), side	a. Swivel connectors (8 and 9)	Tag, loosen, and disconnect	From adapters (19 and 20)
		b. Hose assemblies (10 and 11)	Lay aside	
		c. Two nuts (12)	Remove	
		d. Two strap assemblies (13)	Lift up over fuel tank (14)	
		e. Fuel tank (14)	Remove	From fuel tank brackets (23). Lift fuel tank (14) up and over fuel tank guard (29) with an assistant
DISASSEMBLY				
5	Fuel tank (14)	a. Fitting (15)	Remove	
		b. Pipe plug (16)	Remove	
		c. Clip (17) and baffle (18)	Remove	
		d. Adapters (19 and 20)	Remove	
6	Fuel tank brackets (23)	a. Eight nuts (21) and capscrews (22)	Remove	
		b. Two fuel tank brackets (23)	Remove	From tractor frame rail
		c. Two nuts (24)	Remove	From strap assemblies (13)

2-13. FUEL SYSTEM MAINTENANCE (CONT)

- b. Fuel Tank, Lines and Fittings.
- (1) Fuel Tank (cont).

STEP	LOCATION	ITEM	ACTION	REMARKS
DISASSEMBLY (cont)				
6 (cont)		d. Two strap assemblies (13)	Remove	From fuel tank brackets (23)
		e. Two skid strips (25)	Remove	From strap assemblies (13)
7	Left frame rail	a. Four capscrews (26), nuts (27), and washers (28)	Remove	
		b. Fuel tank guard (29)	Remove	From tractor frame rail

CLEANING

WARNING

Dry cleaning solvent (P-D-680), used to clean parts is toxic and flammable. Wear protective goggles and gloves and use only in a well ventilated area. Avoid contact with skin, eyes, and clothes and don't breathe vapors. Do not use near open flame or excessive heat and don't smoke when using it. Failure to do so could cause serious injury. If you become dizzy while using cleaning solvent, get fresh air and medical attention immediately. If contact with skin or clothes is made, flush with large amounts of water. If contact with eyes is made, wash eyes with water and seek medical aid immediately. Compressed air must not exceed 30 psi. Wear safety glasses when drying parts with compressed air. Failure to do so could cause serious injury to eyes and possible blindness. If you hurt your eyes or if a foreign object is blown into your eyes, seek medical attention immediately.

8	Fuel tank	a. Drain plug (2) (14)	Install and tighten	
		b. Fuel tank (14) interior	Clean	Pour cleaning solvent P-D-680 into tank. Agitate tank

2-13. FUEL SYSTEM MAINTENANCE (CONT)

b. Fuel Tank, Lines and Fittings.

(1) Fuel Tank (cont).

STEP	LOCATION	ITEM	ACTION	REMARKS
CLEANING (cont)				
8 (cont)		c. Drain plug (2)	Remove	Agitate tank while draining cleaning solvent P-D-680 into suitable container. Repeat step until tank interior is clean. Dry with compressed air at 30 psi
		d. All metal parts	Clean	Use cleaning solvent P-D-680; dry with compressed air at 30 psi
		e. Skid strips (25)	Clean	Use mild detergent solution; rinse with clear water
INSPECTION/REPAIR				
9		a. Fuel tank (14)	Inspect	Replace if leaking, cracked, or badly dented
		b. Skid strips (24), strap assemblies (13) and fuel tank brackets (23)	Inspect	Replace if cracked, torn, badly twisted or deteriorated
		c. Fuel tank guard (29) and platform (6)	Inspect for cracks or broken	Repair by welding. Replace a fuel tank guard or platform beyond economical repair welds
		d. Tube (7)	Inspect	Replace if cracked, twisted, dented or otherwise damaged
		e. All other parts	Inspect	Replace if cracked, corroded, or threads damaged
REASSEMBLY				
10	Left frame rail	a. Two skid strips (25)	Install	On strap assemblies (13)
		b. Two strap assemblies (13)	Position	On fuel tank brackets (23)
		c. Two nuts (24)	Install and tighten	On strap assemblies (13)

2-13. FUEL SYSTEM MAINTENANCE (CONT)

b. Fuel Tank, Lines and Fittings.

(1) Fuel Tank (cont).

STEP	LOCATION	ITEM	ACTION	REMARKS
REASSEMBLY (cont)				
10 (cont)		d. Two fuel tank brackets (23)	Position	Against tractor frame rail
		e. Eight capscrews (22) and nuts (21)	Install and tighten	
11	Fuel tank (14)	a. Adapters (19 and 20)	Install and tighten	
		b. Baffle (18) and clip (17)	Install	
		c. Pipe plug (16)	Install and tighten	
		d. Fitting (15)	Install and tighten	
INSTALLATION				
12	Fuel tank brackets (23)	a. Fuel tank (14)	Position	On fuel tank brackets (23)
		b. Two strap assemblies (13)	Pull down over fuel tank (14)	
		c. Two nuts (12)	Install and tighten	
13	Fuel tank (14), side	Swivel connectors (8 and 9) with hose assemblies (10 and 11)	Connect and tighten	To adapters (19 and 20)
14	Fuel tank (14), rear	Tube (7)	Position	
15	Fuel tank (14), top	a. Tube (7)	Connect and tighten	To fitting (15)
		b. Fuel sender	Install	Para 2-32b
		c. Platform (6)	Position	On tractor
		d. Four capscrews (3), lock washers (5), and nuts (4)	Install and tighten	

2-13. FUEL SYSTEM MAINTENANCE (CONT)

- b. Fuel Tank, Lines and Fittings.
 - (1) Fuel Tank (cont).

STEP	LOCATION	ITEM	ACTION	REMARKS
INSTALLATION (cont)				
16	Left frame rail	a. Fuel tank guard (29) b. Four capscrews (26), washers (28), and nuts (27)	Position Install and tighten	On tractor frame rail
17	Fuel tank (14), bottom	Drain plug (2)	Install and tighten	
FILLING				
18	Left side of tractor	a. Fuel tank (14) b. Filler cap (1) c. Fuel tank (14), drain plug (2), and all lines and fittings	Fill Install and tighten Inspect for leaks at drain plug, lines, and fittings. Then stop engine	With fuel (refer to current lubrication order) Start engine, run for several minutes and check for leaks

2-13. FUEL SYSTEM MAINTENANCE (CONT)

b. Fuel Tank, Lines and Fittings.

(2) Lines and Fittings.

This task covers: a. Removal c. Inspection
 b. Cleaning d. Installation

INITIAL SETUP

Tools

No. 1 Common Organizational Maintenance

Tool Kit

Adjustable open end wrench

Safety glasses

Scratch wire brush

Mandrel assembly tool

FSCM 00624 PN 1582-8

Materials/Parts

Cleaning

solvent Item 1, Appendix C

Clean cloths Item 2, Appendix C

Hydraulic oil Item 22, Appendix C

Detergent Item 27, Appendix C

Tie straps FSCM 96906 PN MS3667-1-9

2-13b(1)
2-65c

Personnel Required

Wheel Vehicle Mechanic MOS 63B

References

LO 9-2320-285-12

(M878A1 Lubrication Order)

Equipment Condition

Paragraph	Condition Description
	Vehicle parked on level surface, engine off, and parking brake applied.
	Cab tilted 45 degrees.
	Fuel tank drained.
	Rear platform removed.

KEY

- 1 Swivel connector
- 2 Hose assembly
- 3 Swivel connector
- 4 Hose assembly
- 5 Tie straps (2)
- 6 Swivel connector
- 7 Hose assembly
- 8 Adapter
- 9 Coupling
- 10 Swivel connector
- 11 45 degree connector
- 12 Hose assembly
- 13 Tie straps (4)
- 14 Swivel connector
- 15 Swivel connector
- 16 Hose assembly
- 17 Swivel connector
- 18 Swivel connector
- 19 Hose assembly

- 20 45 degree connector
- 21 Swivel connector
- 22 Tie strap
- 23 Filter head
- 24 Elbows (2)
- 25 Filter head
- 26 Elbows (2)
- 27 Elbows (2)
- 28 Adapter
- 29 Elbow
- 30 Restrictor elbow
- 31 Elbows (2)
- 32 Capscrews and seal washers (3)
- 33 Fuel pump
- 34 Gasket
- 35 Coupling fork
- 36 Elbow
- 37 Connector

2-13. FUEL SYSTEM MAINTENANCE (CONT)

b. Fuel Tank, Lines and Fittings.

(2) Lines and Fittings.

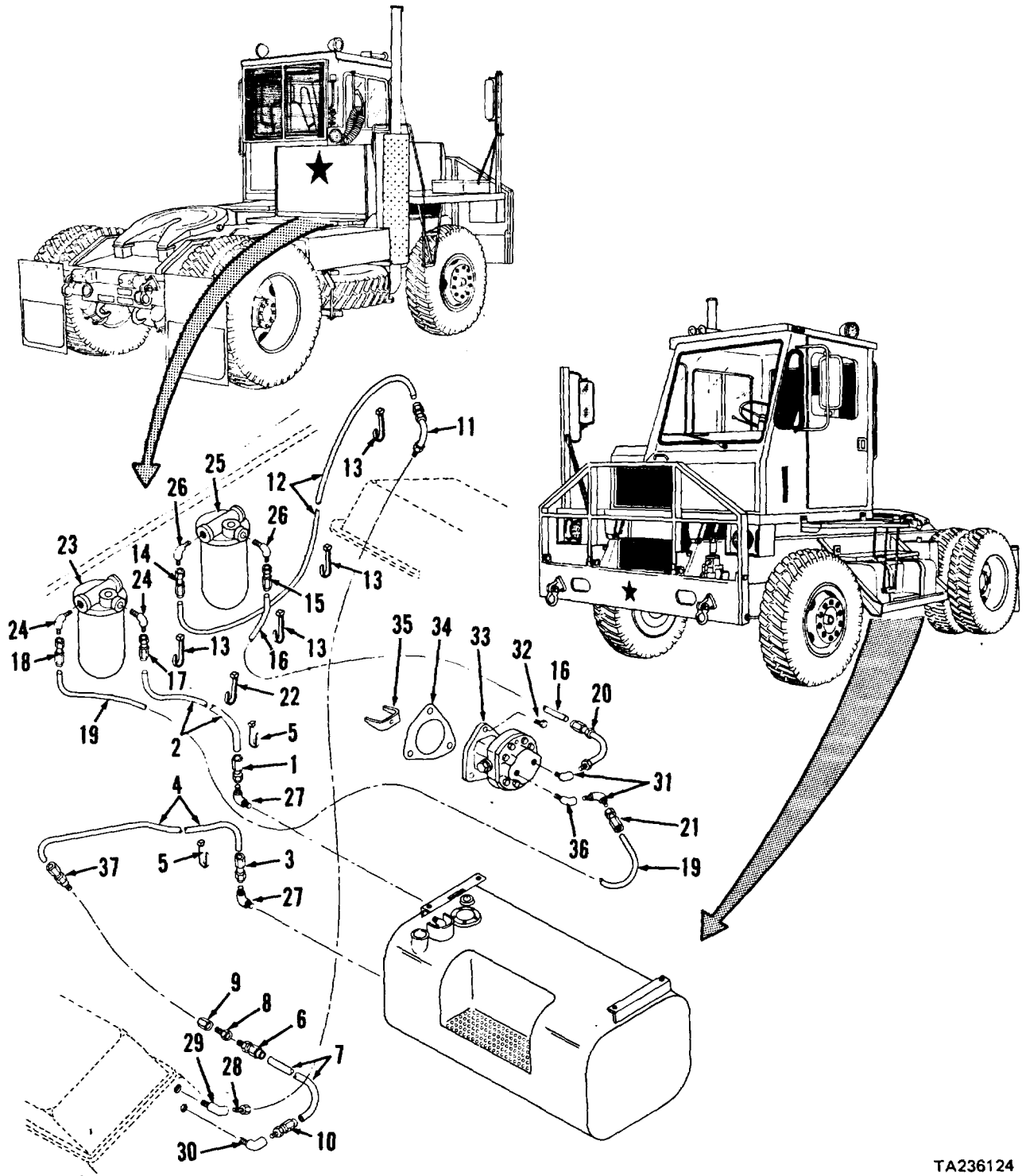

TA236124

2-13. FUEL SYSTEM MAINTENANCE (CONT)

b. Fuel Tank, Lines and Fittings.

(2) Lines and Fittings (cont).

STEP	LOCATION	ITEM	ACTION	REMARKS
------	----------	------	--------	---------

REMOVAL**NOTE**

To aid in installation, tag all hose assemblies before disconnecting and removing from vehicle.

1	Fuel tank, sides	a. Swivel connector (1)	Loosen and disconnect	
		b. Swivel connector (3)	Loosen and disconnect	
2	Left frame rail, bottom	Two tie straps (5)	Cut, remove, and discard	
3	Engine, left side	a. Swivel connector (6)	Loosen and disconnect	
		b. Hose assembly (4), with adapter (8), and coupling (9) installed	Remove	
4	Hose (4)	a. Adapter (8)	Remove	From coupling (9)
		b. Coupling (9)	Remove	From connector (37)
5	Engine, left side, rear	a. Swivel connector (10)	Loosen and disconnect	
		b. Hose assembly (7)	Remove	
		c. 45 degree connector (11)	Loosen and disconnect	
		d. Four tie straps (13)	Cut, remove, and discard	
6	Filter mounting plate; filter head (25)	a. Swivel connector (14)	Loosen and disconnect	
		b. Hose assembly (12)	Remove	
		c. Swivel connector (15)	Loosen and disconnect	
		d. Two elbows (26)	Remove	

2-13. FUEL SYSTEM MAINTENANCE (CONT)

b. Fuel Tank, Lines and Fittings.

(2) Lines and Fittings (cont).

STEP	LOCATION	ITEM	ACTION	REMARKS
REMOVAL (cont)				
7	Filter mounting plate; filter head (23)	a. Swivel connector (17) b. Hose assembly (2) c. Swivel connector (18) d. Two elbows (24)	Loosen and disconnect Remove Loosen and disconnect Remove	
8	Fuel pump (33)	a. 45 degree connector (20) b. Tie strap (22) c. Hose assembly (16) d. Swivel connector (21) e. Hose assembly (19)	Loosen and disconnect Cut, remove and discard Remove Loosen and disconnect Remove	
9	Fuel tank	Two elbows (27)	Remove	
10	Engine, top, rear	a. Adapter (28) b. Elbow (29) c. Restrictor elbow (30) d. Power steering pump	Remove Remove Remove Remove	Para 3-28f (do not disconnect pump lines)
11	Fuel pump (33)	a. Two elbows (31) b. Three capscrews and seal washers (32) c. Fuel pump (33) d. Gasket (34) e. Coupling fork (35) f. Elbow (36)	Remove Remove Remove Remove and discard Remove Remove	Support fuel pump (33) From fuel pump (33)

2-13. FUEL SYSTEM MAINTENANCE (CONT)

- b. Fuel Tank, Lines and Fittings.
- (2) Lines and Fittings (cont).

STEP	LOCATION	ITEM	ACTION	REMARKS
------	----------	------	--------	---------

CLEANING

12		a. Hose assemblies (2, 4, 7, 12, 16, and 19)	Clean	Use clean cloth moistened with detergent; dry using clean cloths
----	--	--	-------	--

WARNING

Dry cleaning solvent (P-D-680), used to clean parts is toxic and flammable. Wear protective goggles and gloves and use only in a well ventilated area. Avoid contact with skin, eyes, and clothes and don't breathe vapors. Do not use near open flame or excessive heat and don't smoke when using it. Failure to do so could cause serious injury. If you become dizzy while using cleaning solvent, get fresh air and medical attention immediately. If contact with skin or clothes is made, flush with large amounts of water. If contact with eyes is made, wash eyes with water and seek medical aid immediately.

		b. Remaining parts	Clean	Use cleaning solvent P-D-680; dry using clean cloths
--	--	--------------------	-------	--

INSPECTION

WARNING

Compressed air must not exceed 30 psi. Wear safety glasses when drying parts with compressed air. Failure to do so could cause serious injury to eyes and possible blindness. If you hurt your eyes or if a foreign object is blown into your eyes, seek medical attention immediately.

13		a. Hose assemblies (2, 4, 7, 12, 16, and 19)	Inspect for cracks chafing splits blockage	Replace if defects observed; remove blockage using compressed air; refer to step 14 below for removal of swivel connectors from hose assemblies
----	--	--	--	---

2-13. FUEL SYSTEM MAINTENANCE (CONT)

b. Fuel Tank, Lines and Fittings.

(2) Lines and Fittings (cont).

STEP	LOCATION	ITEM	ACTION	REMARKS
INSPECTION (cont)				
13 (cont)		b. Swivel connectors (1, 3, 6, 10, 14, 15, 17, 18, 21, and 37) and 45 degree connectors (11 and 20)	Inspect for cracks breaks damaged threads distortion	Replace if defects observed; refer to step 14 below for removal of swivel connectors from hose assembly
		c. Remaining parts	Inspect for cracks breaks distortion damaged threads	Replace if defects observed

REPAIR

WARNING

If swivel connectors (1, 3, 6, 10, 14, 15, 17, 18, 21, or 37) or 45 degree elbows (11 and 20) require replacement, discard hose. If hose is reused, leakage could occur causing a fire hazard.

14	Hose assembly	a. Swivel connector	Place connector socket in vise as shown
		b. Mandrel assembly tool	Install in connector nipple; tighten nut of connector. Turn tool counterclockwise to remove connector nipple and nut
		c. Hose	Turn hose clockwise out of connector socket; discard hose

NOTE

Repeat step 14 above to remove remaining connector from hose.

15	Hose assembly (12 or 16)	a. 45 degree connector (11 or 20)	Place 45 degree connector socket in vise. Turn connector counterclockwise to remove nipple and nut from elbow socket
		b. Hose	Turn hose clockwise out of 45 degree connector socket; discard hose

2-13. FUEL SYSTEM MAINTENANCE (CONT)

- b. Fuel Tank, Lines and Fittings.
- (2) Lines and Fittings (cont).

STEP	LOCATION	ITEM	ACTION	REMARKS
------	----------	------	--------	---------

REPAIR (cont)

WARNING

Dry cleaning solvent (P-D-680), used to clean parts is toxic and flammable. Wear protective goggles and gloves and use only in a well ventilated area. Avoid contact with skin, eyes, and clothes and don't breathe vapors. Do not use near open flame or excessive heat and don't smoke when using it. Failure to do so could cause serious injury. If you become dizzy while using cleaning solvent, get fresh air and medical attention immediately. If contact with skin or clothes is made, flush with large amounts of water. If contact with eyes is made, wash eyes with water and seek medical aid immediately.

16		Swivel connector and/or 45 degree connector	Clean	Use cleaning solvent P-D-680; allow to air dry. Use wire brush to remove all hose residue from socket and/or nipple of connectors
17	Hose	a. Hose	Cut to proper length	Use new hose; use old hose for determining proper length required. Cut hose square using fine tooth hacksaw
		b. Swivel connector	Place connector socket in vise as shown	
		c. Hose	Screw hose counterclockwise into socket until hose bottoms; back hose off 1/4 to 1/2 turn	
		d. Mandrel assembly tool	Oil nipple threads, mandrel assembly tool and inside of hose liberally using hydraulic oil. Tighten connector nipple and nut on mandrel assembly too. Apply oil to all parts	
		e. Swivel connector	Screw nipple clockwise into socket and hose. Allow 1/32 to 1/16 inch clearance between nut and socket so nut will swivel. If connector (37) is being installed, tighten nipple until snug against socket. Remove mandrel assembly tool from connector. Remove connector from vise	

2-13. FUEL SYSTEM MAINTENANCE (CONT)

- b. Fuel Tank, Lines and Fittings.
- (2) Lines and Fittings (cont).

STEP	LOCATION	ITEM	ACTION	REMARKS
------	----------	------	--------	---------

REPAIR (cont)

NOTE

Repeat steps b through e above to install remaining swivel connector on hose; perform step 18 below to install 45 degree connectors (11 or 20) on hose (12 or 16).

18	Hose assembly (12 or 16)	a. 45 degree connector (11 or 20)	Place connector socket in vise
		b. Hose	Screw hose counterclockwise into socket until hose bottoms; back off hose 1/4 to 1/2 turn
		c. 45 degree connector nipple and nut	Oil nipple threads and inside of hose liberally using hydraulic oil. Screw nipple clockwise into socket and hose until nut near nipple bottoms on socket. Remove hose from vise

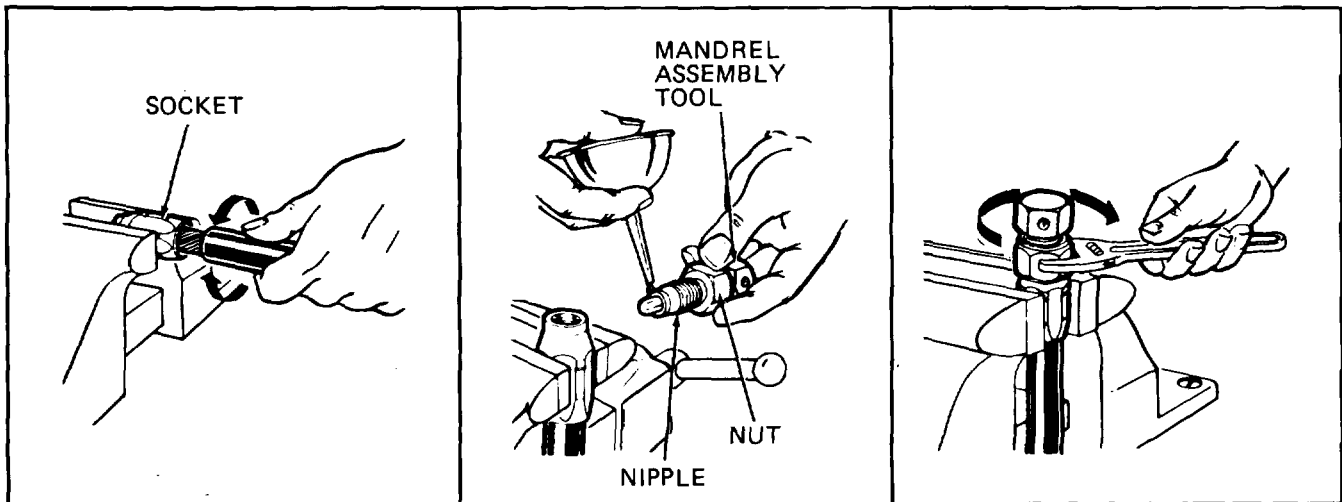

TA236149

INSTALLATION

19	Fuel pump (33)	Elbow (36)	Install
20	Engine, rear	a. Coupling fork (35)	Position
		b. Gasket (34)	Position

2-13. FUEL SYSTEM MAINTENANCE (CONT)

b. Fuel Tank, Lines and Fittings.

(2) Lines and Fittings (cont).

STEP	LOCATION	ITEM	ACTION	REMARKS
INSTALLATION (cont)				
20 (cont)		c. Fuel pump (33)	Position	
		d. Three capscrews and seal washers (32)	Install and tighten	
		e. Power steering pump	Install	Para 3-28f
21	Fuel pump (33)	Two elbows (31)	Install	In fuel pump (33)
22	Engine, left cylinder head, rear	a. Restrictor elbow (30)	Install and tighten	In cylinder head bottom port
		b. Elbow (29)	Install and tighten	In cylinder head top port
		c. Adapter (28)	Install and tighten	In elbow (29)
23	Fuel tank, side	Two elbows (27)	Install and tighten	
24	Filter head (25)	Two elbows (26)	Install and tighten	
25	Filter head (23)	Two elbows (24)	Install and tighten	
26	Fuel pump (33)	a. Hose assembly (16)	Route	Between fuel pump and filter head (25)
		b. 45 degree connector (20)	Connect and tighten	To elbow (31) as shown
		c. Hose assembly (19)	Route	Between fuel pump and filter head (23)
		d. Swivel connector (21)	Connect and tighten	To elbow (31) as shown
27	Filter head (23)	a. Swivel connector (18)	Connect and tighten	To elbow (24) as shown
		b. Hose assembly (2)	Route	Between filter head (23) and fuel tank
		c. Swivel connector (17)	Connect and tighten	To elbow (24) as shown
28	Filter head (25)	a. Swivel connector (15)	Connect and tighten	To elbow (26) as shown

2-13. FUEL SYSTEM MAINTENANCE (CONT)

b. Fuel Tank, Lines and Fittings.

(2) Lines and Fittings (cont).

STEP	LOCATION	ITEM	ACTION	REMARKS
INSTALLATION (cont)				
28 (cont)		b. Hose assembly (12)	Route	Between filter head (25) and engine left cylinder head, rear
		c. Swivel connector (14)	Connect and tighten	To elbow (26) as shown
29	Engine, left side, rear	a. 45 degree connector (11)	Connect and tighten	To adapter (28)
		b. Rose assembly (4)	Route	Between fuel tank and left cylinder head
		c. Coupling (9)	Install	On connector (37)
		d. Adapter (8)	Install	In coupling (9)
		e. Swivel connector (6)	Connect and tighten	To adapter (8) on hose assembly (4)
30	Fuel tank, side	a. Swivel connector (3)	Connect and tighten	To elbow (27) as shown
		b. Swivel connector (1)	Connect and tighten	To elbow (27) as shown
31	Engine, left side, rear	Four new tie straps (13) and tie strap (22)	Install	Secure hose assemblies
32	Left frame rail, bottom	Two new tie straps (5)	Install	Secure hose assemblies
33	Fuel tank	Filler neck	Fill	With fuel (refer to current lubrication order)
34	Rear of vehicle	Rear platform	Install	Para 2-65c
35	Cab tilt pump	Cab	Lower	To normal driving position

NOTE

Start engine and check all connections at filter heads, fuel pump, fuel tank, and cylinder head for fuel leaks; tighten connections as necessary.

2-13. FUEL SYSTEM MAINTENANCE (CONT)

- c. Fuel Filters. This task covers:
- a. Servicing
 - b. Removal
 - c. Cleaning
 - d. Inspection
 - e. Installation

INITIAL SETUP

Tools

- No. 1 Common Organizational Maintenance Tool Kit
 - Open end wrench, adjustable
 - Safety glasses
 - Strap type oil filter wrench

Personnel Required

Wheel Vehicle Mechanic MOS 63B

Equipment Condition

Paragraph	Condition Description
	Vehicle parked on level surface, parking brake applied; engine off.
2-65c	Rear platform removed.

Materials/Parts

- Cleaning solvent Item 1, Appendix C
- Clean cloths Item 2, Appendix C
- Primary fuel
 - filter element FSCM 72582 PN 25010778
- Secondary fuel
 - filter element FSCM 72582 PN 2501776

STEP	LOCATION	ITEM	ACTION	REMARKS
------	----------	------	--------	---------

SERVICING

WARNING

Diesel fuel is highly combustible. When performing the following steps, do not smoke or allow open flames or sparks in the area. Death or severe injury may result if personnel fail to observe this precaution. If you are burned, obtain medical attention immediately.

1	Below cab guard	a. Filter elements (1 and 2)	Remove and discard	Use filter wrench; turn counterclockwise to remove
---	-----------------	------------------------------	--------------------	--

CAUTION

Do not use tools to tighten filter elements. Hand tighten only.

	b. New filter elements (1 and 2)	a. Fill	Fill approximately 2/3 full with clean diesel fuel. Lightly coat each element gasket with diesel fuel
		b. Install	Turn clockwise until gasket contacts base; then tighten an additional 1/2 to 3/4 turn to obtain proper seal

2-13. FUEL SYSTEM MAINTENANCE (CONT)

c. Fuel Filters (cont).

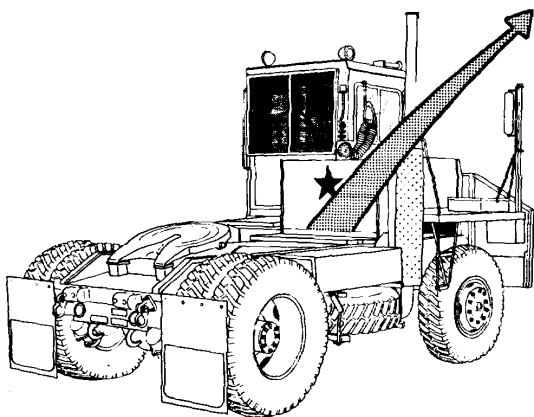
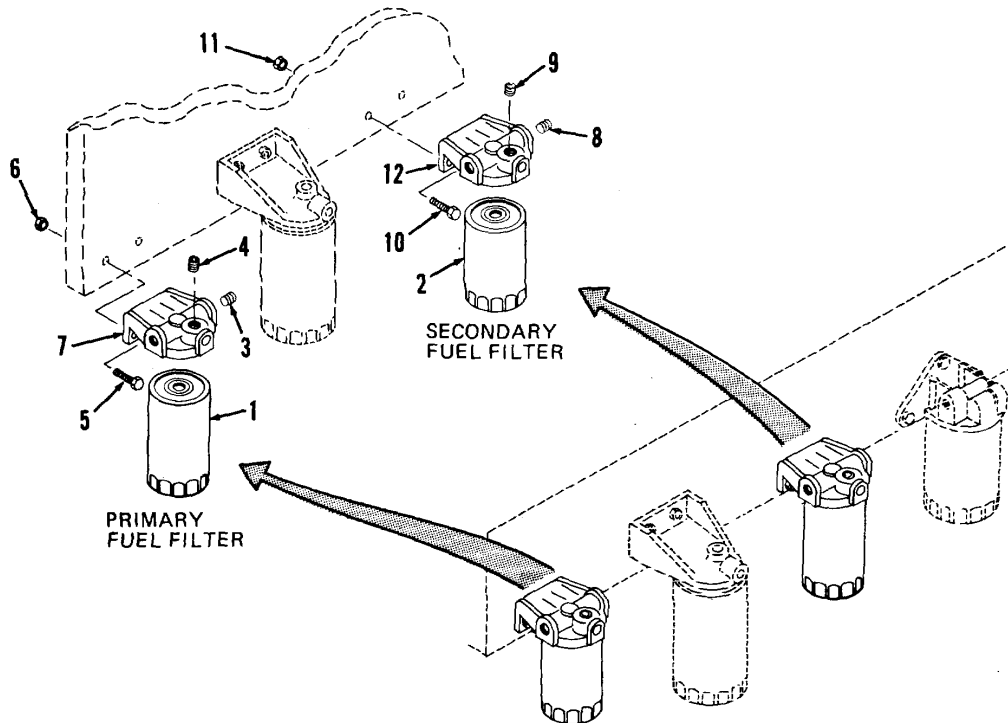

KEY

- 1. Primary filter element
- 2. Secondary filter element
- 3. Plug
- 4. Plug
- 5. Capscrews (2)
- 6. Locknuts (2)
- 7. Primary filter head
- 8. Plug
- 9. Plug
- 10. Capscrews (2)
- 11. Locknuts (2)
- 12. Secondary filter head

2-93

TA236125

2-13. FUEL SYSTEM MAINTENANCE (CONT)

c. Fuel Filters (cont).

STEP	LOCATION	ITEM	ACTION	REMARKS
SERVICING (cont)				
1 (cont)			c. Check	Start engine, run for several minutes, and inspect for leaks at filters. Then stop engine
REMOVAL				
2	Primary filter head (7)	a. Primary filter element (1) b. Filter head (7) lines c. Plugs (3 and 4) d. Two capscrews (5) and locknuts (6) e. Primary filter head (7)	Remove Loosen, disconnect, and remove Remove Remove Remove	Use filter wrench; turn counterclockwise to remove Para 2-13b(2) Support filter head (7)
3	Secondary filter head (12)	a. Secondary filter element (2) b. Filter head (12) lines c. Plugs (8 and 9) d. Two capscrews (10) and locknuts (11) e. Secondary filter head (12)	Remove Loosen, disconnect, and remove Remove Remove Remove	Use filter wrench; turn counterclockwise to remove Para 2-13b(2) Support filter head (12)

CLEANING

WARNING

Dry cleaning solvent (P-D-680), used to clean parts is toxic and flammable. Wear protective goggles and gloves and use only in a well ventilated area. Avoid contact with skin, eyes, and clothes and don't breathe vapors. Do not use near open flame or excessive heat and don't smoke when using it. Failure to do so could cause serious injury. If you become dizzy while using cleaning solvent, get fresh air and medical attention immediately. If contact with skin or clothes is made, flush with large amounts of water. If contact with eyes is made wash eyes with water and seek medical aid immediately.

2-13. FUEL SYSTEM MAINTENANCE (CONT)

c. Fuel Filters (cont).

STEP	LOCATION	ITEM	ACTION	REMARKS
------	----------	------	--------	---------

CLEANING (cont)

WARNING

Compressed air must not exceed 30 psi. Wear safety glasses when drying parts with compressed air. Failure to do so could cause serious injury to eyes and possible blindness. If you hurt your eyes or if a foreign object is blown into your eyes, seek medical attention immediately.

4		Filter heads (7 and 12)	Clean	Use cleaning solvent P-D-680; dry with compressed air
---	--	-------------------------	-------	---

INSPECTION

5		a. Filter heads (7 and 12)	Inspect	Replace if cracked or threads damaged
		b. Capscrews (5 and 10), locknuts (6 and 11), and plugs (3, 4, 8, and 9)	Inspect	Replace if threads damaged

INSTALLATION

6	Secondary filter head (12)	a. Plugs (8 and 9)	Install and tighten	
		b. Secondary filter head (12)	Position	
		c. Two capscrews (10) and locknuts (11)	Install and tighten	
		d. Filter head (12) lines	Connect and tighten	Pars 2-13b(2)
7	Primary filter head (7)	a. Plugs (3 and 4)	Install and tighten	
		b. Primary filter head (7)	Position	
		c. Two capscrews (5) and locknuts (6)	Install and tighten	

2-13. FUEL SYSTEM MAINTENANCE (CONT)

c. Fuel Filters (cont).

STEP	LOCATION	ITEM	ACTION	REMARKS
INSTALLATION (cont)				
7 (cont)		d. Filter head (7) lines	Connect and tighten	Para 2-13b(2)

CAUTION

Do not use tools to tighten filter elements. Hand tighten only.

8	Below cab guard	New filter elements (1 and 2)	a. Fill	Fill approximately 2/3 full with clean diesel fuel. Lightly coat each element gasket with diesel fuel Turn clockwise until gasket contacts base; then tighten an additional 1/2 to 3/4 turn to obtain proper seal Start engine, run for several minutes, and inspect for leaks at filters and lines. Then stop engine
			b. Install	
			c. Check	
9	Behind cab guard	Rear platform	Install	Para 2-65c

2-13. FUEL SYSTEM MAINTENANCE (CONT)

d. Quick Start.

This task covers:

- a. Removal/Disassembly
- b. Cleaning

- c. Inspection
- d. Reassembly/Installation

INITIAL SETUP

Tools

No. 1 Common Organizational Maintenance

Tool Kit

- Adjustable open end wrench
- Socket wrench set
- Safety glasses
- Tool kit, electrical connector
- Crimping tool
- Wire stripper

Personnel Required

Wheel Vehicle Mechanic MOS 63B

Equipment Condition

Paragraph Condition Description

Parked on level surface;
parking brake applied; engine
off.
Cab tilted 45 degrees.

2-15a(l) Coolant drained from radiator.

Materials/Parts

- Cleaning solvent Item 1, Appendix C
- Clean cloths Item 2, Appendix C
- Ether cylinder FSCM 61112 PN LP535
- Crimp connector FSCM 90915 PN 90828080

STEP	LOCATION	ITEM	ACTION	REMARKS
------	----------	------	--------	---------

REMOVAL/DISASSEMBLY

WARNING

Cylinder (4) contains ether which is highly flammable and under pressure. Do not puncture cylinder (4) or discard in an open fire. When performing the following steps, do not smoke or allow open flames or sparks into the area. Death or severe injury may result if personnel fail to observe this precaution. If you are burned, obtain medical attention immediately.

1	Air cleaner, left side, rear	a. Two wing nuts (1), lock washers (2), and bracket (3)	Remove	
		b. Cylinder (4) remove	Unscrew and	From ether valve (22); then gently shake cylinder to estimate quantity of ether remaining. Empty cylinder weight is approximately 17 ounces; full cylinder weight is approximately 37 ounces

2-13. FUEL SYSTEM MAINTENANCE (CONT)

d. Quick Start (cont).

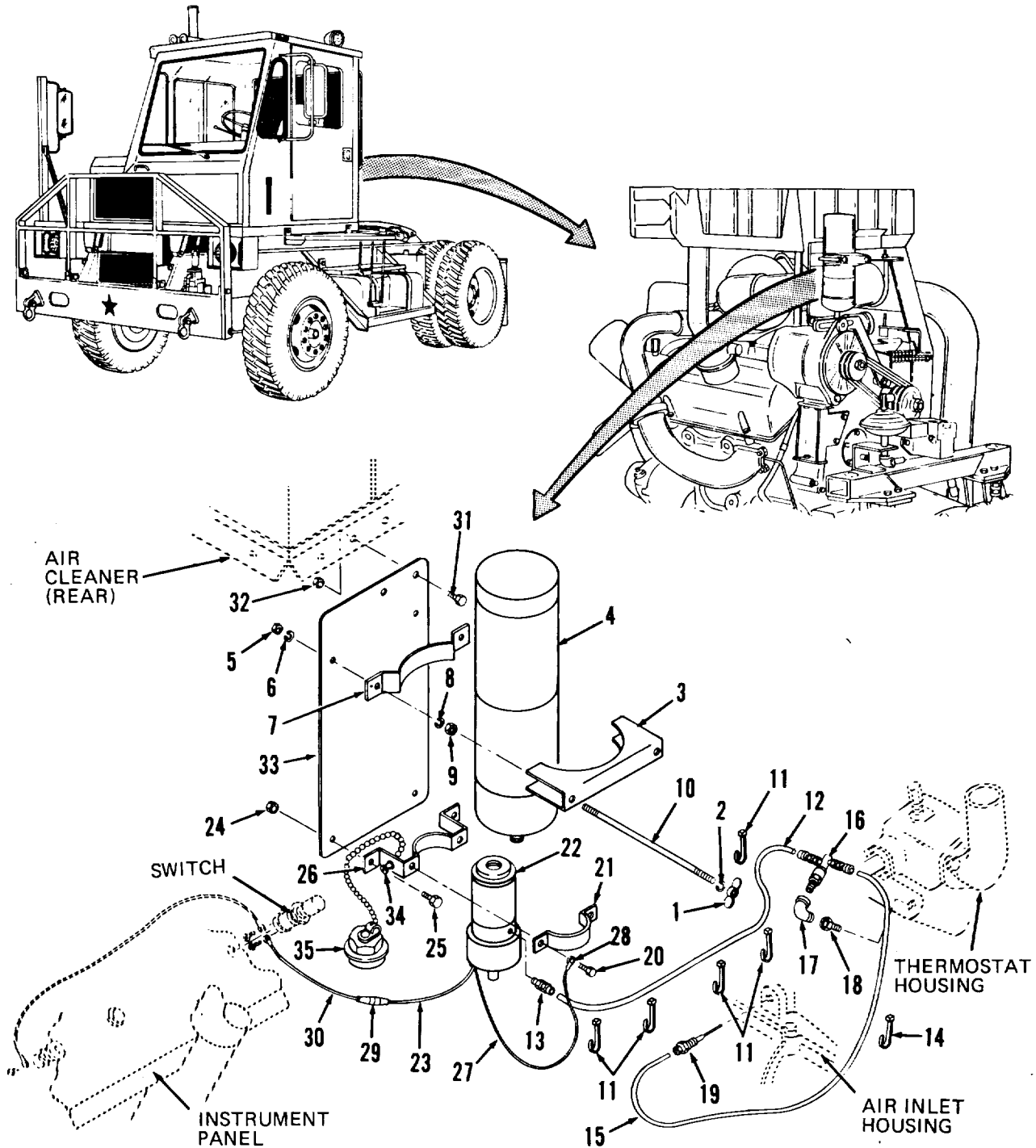

TA236127

2-13. FUEL SYSTEM MAINTENANCE (CONT)

d. Quick Start (cont).

KEY

- | | | |
|---------------------|-------------------|-----------------------|
| 1. Wing nuts (2) | 13. Fitting | 25. Capscrews (2) |
| 2. Lock washers (2) | 14. Tie strap | 26. Bracket |
| 3. Bracket | 15. Tube | 27. Ground wire (BLK) |
| 4. Cylinder | 16. Control valve | 28. Terminal |
| 5. Nuts (2) | 17. Elbow | 29. Crimp connector |
| 6. Lock washers (2) | 18. Bushing | 30. Wire (YEL/BLK) |
| 7. Bracket | 19. Atomizer | 31. Capscrews (2) |
| 8. Lock washers (2) | 20. Capscrews (2) | 32. Locknuts (2) |
| 9. Nuts (2) | 21. Bracket | 33. Bracket |
| 10. Studs (2) | 22. Ether valve | 34. Clip |
| 11. Tie straps (2) | 23. Wire (BLK) | 35. Cap |
| 12. Tube | 24. Locknuts (2) | |

STEP	LOCATION	ITEM	ACTION	REMARKS
REMOVAL/DISASSEMBLY (cont)				
1 (cont)		c. Two nuts (5), lock washers (6), bracket (7), lock washers (8), nuts (9), and studs (10)	Remove	
		d. Tube (12)		Disconnect
		e. Fitting (13)	Remove	From valve (22)

NOTE

Cut, remove, and discard tie straps (11 and 14) as necessary in the following steps. Note locations to aid installation.

2	Thermostat housing, left side	a. Tube (12) and remove	Disconnect	
		b. Tube (15) and remove	Disconnect	
		c. Control valve (16)	Remove	
		d. Elbow (17)	Remove	Disconnect adjacent fuel line for access
		e. Bushing (18)	Remove	

2-13. FUEL SYSTEM MAINTENANCE (CONT)

d. Quick Start (cont).

STEP	LOCATION	ITEM	ACTION	REMARKS
REMOVAL/DISASSEMBLY (cont)				
3	Air inlet housing, right side	a. Tube (15) b. Atomizer (19)	Disconnect and remove Remove	
4	Air cleaner, left side, rear	a. Crimp connector (29) b. Two capscrews (20) and bracket (21) c. Ether valve (22) d. Clip (34) e. Cap (35) f. Two locknuts (24), capscrews (25), and bracket (26) g. Two capscrews (31) and locknuts (32) h. Bracket (33)	Remove and Remove Remove Remove Remove Remove Remove	Cut wires (23 and 30) as discard close as possible to connector (29) From cap (35) chain; route chain through hole in bracket (26) to remove clip (34) Slip cap chain through hole in bracket (26) Support bracket (33)
CLEANING				
5		a. Ether valve (22)	Clean	Wipe with clean, dry cloth

WARNING

Dry cleaning solvent (P-D-680), used to clean parts is toxic and flammable. Wear protective goggles and gloves and use only in a well ventilated area. Avoid contact with skin, eyes, and clothes and don't breathe vapors. Do not use near open flame or excessive heat and don't smoke when using it. Failure to do so could cause serious injury. If you become dizzy while using cleaning solvent, get fresh air and medical attention immediately. If contact with skin or clothes is made, flush with large amounts of water. If contact with eyes is made wash eyes with water and seek medical aid immediately.

2-13. FUEL SYSTEM MAINTENANCE (CONT)

d. Quick Start (cont).

STEP	LOCATION	ITEM	ACTION	REMARKS
------	----------	------	--------	---------

CLEANING (cont)

5

WARNING

(cont)

Compressed air must not exceed 30 psi. Wear safety glasses when drying parts with compressed air. Failure to do so could cause serious injury to eyes and possible blindness. If you hurt your eyes or if a foreign object is blown into your eyes, seek medical attention immediately.

		b. All metal parts except ether valve (22)	Clean	Use cleaning solvent P-D-680; dry with compressed air
		c. Tubes (12 and 15)	Clean	Wipe with clean, dry cloth

INSPECTION

6

		a. Tubes (12 and 15) and atomizer (19)	Inspect	Apply compressed air at 10 psi, check for obstructions. Replace tube if obstructed, cracked, or deteriorated
		b. Wiring	Inspect	Replace if insulation frayed or cracked, or conductor corroded or broken
		c. Ether valve (22)	Inspect	Connect momentarily to 12 volt battery. If clicking sound is not heard, valve solenoid is defective. Replace if defective
		d. All other parts	Inspect	Replace if bent, cracked, dented, or threads damaged

REASSEMBLY/INSTALLATION

7

Air cleaner, left side, rear

		a. Bracket (33)	Position	At first and second hole (from left side) on air cleaner
		b. Two capscrews (31) and locknuts (32)	Install and tighten	

2-13. FUEL SYSTEM MAINTENANCE (CONT)

d. Quick Start (cont).

STEP	LOCATION	ITEM	ACTION	REMARKS
REASSEMBLY/INSTALLATION (cont)				
7 (cont)		c. Bracket (26)		Position On bracket (33)
		d. Two capscrews (25) and locknuts (24)		Install and tighten
		e. Cap (35)	Install	Route cap chain through hole in bracket (26)
		f. Clip (34)	Install	On end of cap (35) chain; secures cap (35) to bracket (36)
		g. Terminal (28)	Install	On wire (27) if new valve (22) is being installed. Strip 1/4 inch insulation from wire (27) and crimp terminal to wire securely
		h. Ether valve (22)	Position	On bracket (26)
		i. Bracket (21)	Position	
		j. Ground wire (27) terminal (28)	Position	On capscrew (20)
		k. Two capscrews (20)	Install and tighten	
	8	Air inlet housing, right side	a. Atomizer (19)	Install
b. Tube (15)			Route between atomizer (19) and control valve (16). Connect to atomizer	
c. Tie strap (14)			Install	Around fuel and air lines to secure tube (15)
9	Thermostat housing, left side	a. Bushing (18)	Install and tighten	
		b. Elbow (17)	Install and tighten	Connect adjacent fuel line
		c. Control valve (16) tighten	Install and	
		d. Two tubes (12 and 15)	Route and connect	
		e. Tie straps (11)	Install	Secures tube (12) to existing lines

2-13. FUEL SYSTEM MAINTENANCE (CONT)

d. Quick Start (cont).

STEP	LOCATION	ITEM	ACTION	REMARKS
REASSEMBLY/INSTALLATION (cont)				
10	Air cleaner, left side, rear	a. Fitting (13) b. Tube (12) c. Bracket (7) d. Two studs (10), lock washers (6), nuts (5), lock washers (8), and nuts (9)	Install and tighten Route and connect Position Install and tighten	In ether valve (22)
11	Ether valve (22)	a. Wire (23) and wire (30) b. Crimp connector (29)	a. Strip 1/4 inch insulation from wire ends b. Install wire ends in crimp connector (29) Crimp securely	To wires (23 and 30)
12	Air cleaner, left side, rear	a. Cylinder (4) b. Mounting bracket (3) c. Two lock washers (2) and wing nuts (1)	Install Install on studs (10) Install and tighten	Screw hand tight into ether valve (22)

NOTE

Fill radiator with coolant (para 2-15a(1)) and lower cab to normal operating position.

2-13. FUEL SYSTEM MAINTENANCE (CONT)

e. Accelerator and Throttle Linkage.

This task covers:

- a. Removal
- b. Cleaning
- c. Inspection
- d. Installation
- e. Adjustments

INITIAL SETUP

Tools

No. 1 Common Organizational Maintenance Tool Kit

- Combination wrench set
- Socket wrench set

Automotive Mechanic's Tool Kit

- File
- Hammer
- Punch
- Pliers

Personnel Required

Wheel Vehicle Mechanic MOS 63B

References

TM 9-2815-205-34 (6V53T Diesel Engine Manual, needed for direct support maintenance required work)

Equipment Condition

Paragraph Condition Description

Materials/Parts

Cleaning solvent Item 1, Appendix C
 Clean cloths Item 2, Appendix C
 Detergent Item 27, Appendix C

Parked on level surface;
 parking brake applied; engine off.
 Cab tilted 45 degrees.

KEY

- | | | |
|-----------------------|------------------------------|----------------------|
| 1. Spring | 24. Spring | 46. Nut |
| 2. Lever | 25. Modulator cable assembly | 47. Lock washer |
| 3. Bracket | 26. Nuts (2) | 48. Capscrew |
| 4. Nut | 27. Lock washers (2) | 49. Clamp |
| 5. Lock washer | 28. Screws (2) | 50. Bracket |
| 6. Ball joint | 29. Clamp | 51. Nuts (2) |
| 7. Bracket | 30. Spacer | 52. Lock washers (2) |
| 8. Nut | 31. Nuts (2) | 53. Locknut |
| 9. Boot | 32. Capscrews (2) | 54. Lock washer |
| 10. Pedal assembly | 33. Lever | 55. Washer |
| 11. Accelerator cable | 34. Throttle arm | 56. Nuts (2) |
| 12. Capscrew | 35. Capscrews (2) | 57. Lock washers (2) |
| 13. Nut | 36. Lock washers (2) | 58. Bearing block |
| 14. Lock washer | 37. Capscrew | 59. Bushings (2) |
| 15. Clamp | 38. Lock washer | 60. Shaft assembly |
| 16. Tie strap | 39. Locknut | 61. Shoulder bolt |
| 17. Tie strap | 40. Lock washer | 62. Nylon roller |
| 18. Bracket | 41. Ball joint | 63. Lock ring |
| 19. Locknut | 42. Accelerator lever | 64. Capscrew |
| 20. Capscrew | 43. Nut | 65. Nut |
| 21. Washer | 44. Boot | 66. Capscrews (2) |
| 22. Nut | 45. Nut | 67. Lock washers (2) |
| 23. Nut | | |

2-13. FUEL SYSTEM MAINTENANCE (CONT)

e. Accelerator and Throttle Linkage (cont).

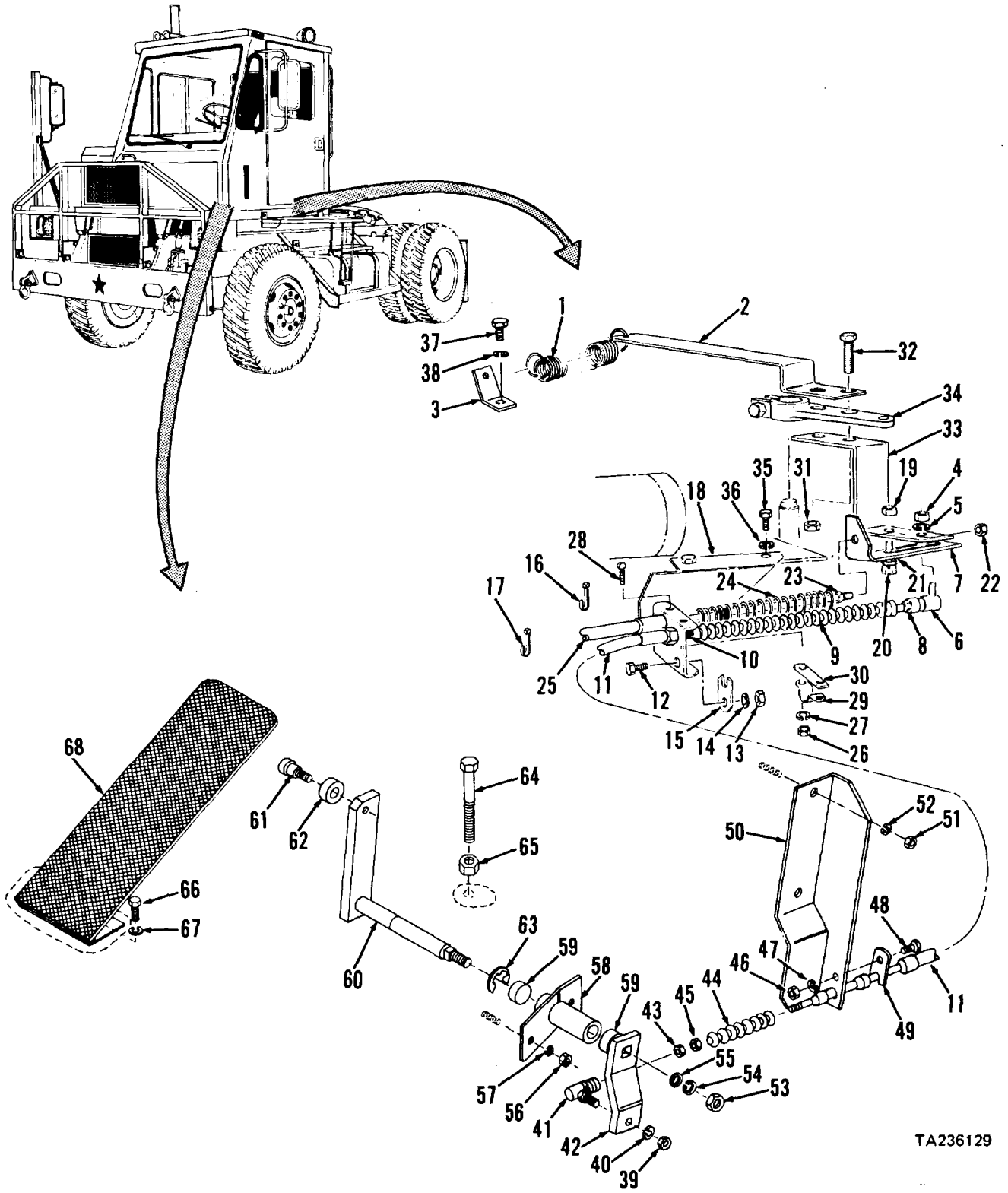

TA236129

2-13. FUEL SYSTEM MAINTENANCE (CONT)

e. Accelerator and Throttle Linkage (cont).

STEP	LOCATION	ITEM	ACTION	REMARKS
REMOVAL				
<u>CAUTION</u>				
Don't attempt to start engine with accelerator/throttle linkage at any stage of removal. To do so could cause serious damage to parts and engine.				
1	Engine, rear	a. Spring (1)	Disconnect	From lever (2) and bracket (3)
		b. Nut (4) and lock washer (5)	Remove	From ball joint (6)
		c. Ball joint (6)	Remove	From lever (33)
		d. Nut (8)	Loosen	
		e. Ball joint (6)	Remove	From cable (11)
		f. Nut (8)	Remove	From cable (11)
		g. Boot (9)	Remove	From cable (11)
		h. Capscrew (12), nut (13), and lock washer (14)	Remove	
		i. Clamp (15)	Remove	
		j. Tie straps (16 and 17)	Cut, remove, and discard	
		k. Cable (11)	Remove	From bracket (18)
		l. Locknut (19), capscrew (20), and washer (21)	Remove	From bracket (7)
		m. Nut (22)	Remove	
		n. Bracket (7)	Remove	From cable (25)
		o. Nut (23) and spring (24)	Remove	From cable (25)
		p. Two nuts (26), lock washers (27), and screws (28)	Remove	
		q. Clamp (29) and spacer (30)	Remove	
		r. Cable (25)	Remove	From bracket (18)
		s. Two nuts (31) and capscrews (32)	Remove	
		t. Levers (2 and 33)	Remove	From throttle arm (34)

2-13. FUEL SYSTEM MAINTENANCE (CONT)

e. Accelerator and Throttle Linkage (cont).

STEP	LOCATION	ITEM	ACTION	REMARKS
REMOVAL (cont)				
1 (cont)		u. Two capscrews (35) and lock washers (36)	Remove	
		v. Bracket (18)	Remove	
		w. Capscrew (37) and lock washer (38)	Remove	
		x. Bracket (3)	Remove	
2	Engine, governor housing	Throttle arm (34) (notify direct support maintenance)	Remove	Refer to TM 9-2815-205-34
3	Cab, side	a. Locknut (39) and lock washer (40)	Remove	
		b. Ball joint (41)	Disconnect	From accelerator lever (42)
		c. Nut (43)	Loosen	
		d. Ball joint (41)	Remove	From cable (11)
		e. Nut (43)	Remove	
		f. Boot (44)	Remove	From cable (11)
		g. Nut (45)	Remove	
		h. Nut (46), lock washer (47), and capscrew (48)	Remove	
		i. Clamp (49)	Remove	
		j. Accelerator cable (11)	Disconnect	From bracket (50)

NOTE

To complete removal of accelerator cable (11), cut, remove, and discard two tie straps securing cable toradiator brace.

k. Two nuts (51), and lock washers (52)	Remove	From studs welded to cab firewall
l. Bracket (50)	Remove	

2-13. FUEL SYSTEM MAINTENANCE (CONT)

e. Accelerator and Throttle Linkage (cont).

STEP	LOCATION	ITEM	ACTION	REMARKS
REMOVAL (cont)				
3 (cont)		m. Locknut (53), lock washer (54), and washer (55)	Remove	
		n. Accelerator lever (42)	Remove	
		o. Two nuts (56) and lock washers (57)	Remove	From studs welded to cab firewall
		p. Assembled bear- ing block (58) and two bush- ings (59)	Remove	
		q. Cab	Lower	To normal position
4	Cab, interior	Shaft assembly (60)	Remove firewall	Remove by pulling from cab

NOTE

Exposed threads of shoulder bolt (61) are staked during assembly to retain bolt. If necessary to remove bolt, chase threads using proper size die or a small file.

5	Shaft assembly (60)	a. Shoulder bolt (61)	Remove	
		b. Nylon roller (62)	Remove	
		c. Lock ring (63)	Remove	
6	Cab, interior	a. Capscrew (64) and nut (65)	Remove	
		b. Two capscrews (66) and lock washers (67)	Remove	
		c. Pedal assembly (10)	Remove	

2-13. FUEL SYSTEM MAINTENANCE (CONT)

e. Accelerator and Throttle Linkage (cont).

STEP	LOCATION	ITEM	ACTION	REMARKS
CLEANING				
7		a. Accelerator cable (11) and modulator cable assembly (25)	Clean	Use clean cloth moistened with detergent; dry using clean cloths

WARNING

Dry cleaning solvent (P-D-680), used to clean parts is toxic and flammable. Wear protective goggles and gloves and use only in a well ventilated area. Avoid contact with skin, eyes, and clothes and don't breathe vapors. Do not use near open flame or excessive heat and don't smoke when using it. Failure to do so could cause serious injury. If you become dizzy while using cleaning solvent, get fresh air and medical attention immediately. If contact with skin or clothes is made, flush with large amounts of water. If contact with eyes is made, wash eyes with water and seek medical aid immediately.

		b. Remaining parts	Clean	Use cleaning solvent P-D-680; dry using clean cloths
--	--	--------------------	-------	--

INSPECTION

8		a. Springs (1 and 24)	Inspect for deformation permanent set	Replace if defects observed
		b. Accelerator cable (11) and modulator cable assembly (25)	Inspect for freedom of movement kinks damage	Replace if defects observed
		c. Nylon roller (62)cracks	Inspect for	Replace if defects observed
		d. Pedal assembly (10)	flat spots Inspect for	Replace if defects observed damaged hinge

2-13. FUEL SYSTEM MAINTENANCE (CONT)

e. Accelerator and Throttle Linkage (cont).

STEP	LOCATION	ITEM	ACTION	REMARKS
INSPECTION (cont)				
8 (cont)		e. Bearing block (58) and bushings (59)	Inspect for cracks breaks	Replace if defects observed. Remove bushings (59) by pressing out of bearing block using proper size sleeve. Install new bushings by pressing into bearing block
		f. Remaining parts	Inspect for cracks breaks deformation wear damaged threads	Replace if defects observed
INSTALLATION				
9	Cab interior	a. Pedal assembly (10)	Position	
		b. Two lock washers (67) and capscrews (66)	Install and tighten	
		c. Nut (65) and capscrew (64)	Install	Don't tighten nut (65)
10	Shaft assembly (60)	a. Nylon roller (62)	Position	On shoulder bolt (61)
		b. Shoulder bolt (61) with nylon roller installed	Install	In shaft assembly (60); use a punch and hammer to stake threads
		c. Lock ring (63)	Install	On shaft assembly (60)
11	Cab interior	a. Shaft assembly (60)	Install	In hole in cab firewall
		b. Cab	Tilt 45 degrees	
12	Cab side	a. Assembled bearing block (58) and two bushings (59)	Install	On shaft assembly (60)

2-13. FUEL SYSTEM MAINTENANCE (CONT)

e. Accelerator and Throttle Linkage (cont).

STEP	LOCATION	ITEM	ACTION	REMARKS
INSTALLATION (cont)				
12 (cont)		b. Two lock washers (57) and nuts (56)	Install and tighten	On studs welded to cab fire-wall
		c. Accelerator lever (42)	Position	On shaft assembly (60)
		d. Washer (55), lock washer (54), and locknut (53)	Install and tighten	
		e. Bracket (50)	Position	
		f. Two lock washers (52) and nuts (51)	Install and tighten	On studs welded to cab fire-wall; secures bracket (50)
		13	Accelerator	a. Nut (45) cable (11)
b. Rubber boot (44)	Install			On accelerator cable (11); connect to cable housing
c. Nut (43)	Install			On accelerator cable (11)
d. Ball joint (41)	Install			On accelerator cable (11) all the way then back off one turn or until ball joint lines up with hole in accelerator lever (42)
14	Cab side	a. Accelerator cable (11)	Install	Slide into bracket (50)
		b. Clamp (49)	Position	On accelerator cable (11) and against bracket (50)
		c. Capscrew (48), lock washer (47), and nut (46)	Install and tighten	
		d. Nut (43)	Tighten	On accelerator cable (11)
		e. Ball joint (41)	Install	On accelerator lever (42)
		f. Lock washer (40) and locknut (39)	Install and tighten	
15	Engine governor housing	a. Throttle arm (34)	Install	Refer to TM 9-2815-205-34 (notify direct support maintenance)
		b. Bracket (18)	Position	

2-13. FUEL SYSTEM MAINTENANCE (CONT)

e. Accelerator and Throttle Linkage (cont).

STEP	LOCATION	ITEM	ACTION	REMARKS
INSTALLATION (cont)				
15 (cont)		c. Two lock washers (36) and capscrews (35)	Install and tighten	
		d. Bracket (3)	Position	
		e. Lock washer (38) and	Install and tighten capscrew (37)	
		f. Accelerator cable (11)	Route and connect	Between pedal assembly (10) and bracket (18); connect to bracket (18)
		g. Modulator cable assembly (25)	Connect	To bracket (18)
		h. Clamp (15)	Position	
		i. Capscrew (12), lock washer (14), and nut (13)	Install and tighten	
		j. Spacer (30) and clamp (29)	Position	
		k. Screws (28), lock washers (27), and nuts (26)	Install and tighten	
16	Throttle arm (34)	a. Lever (2)	Position	On throttle arm (34)
		b. Lever (33)	Position	On throttle arm (34)
		c. Two capscrews (32) and locknuts (31)	Install and tighten	
		d. Spring (1)	Connect	Between lever (2) and bracket (3)
		e. New tie straps (16 and 17)	Install	
17	Accelerator cable (11)	a. Boot (9)	Install	Against bracket (18); connect over cable (11) housing
		b. Nut (8)	Install	Until almost touching boot (9)

2-13. FUEL SYSTEM MAINTENANCE (CONT)

e. Accelerator and Throttle Linkage (cont).

STEP	LOCATION	ITEM	ACTION	REMARKS
INSTALLATION (cont)				
17 (cont)		c. Ball joint (6)	Install	On accelerator cable (11); screw all the way on then back-off one turn or until stud is in correct position to install in lever (33)
		d. Ball joint (6) stud	Connect	To lever (33)
		e. Lock washer (5) and nut (4)	Install and tighten	
18	Modulator cable assembly (25)	a. Nut (23)	Install	Almost to end of threads on modulator cable assembly (25)
		b. Spring (24) and bracket (7)	Position	On cable (25) shaft
		c. Nut (22)	Install and tighten	Secures spring (24) and bracket (7) to cable (25)
19	Lever (33)	a. Bracket (7) b. Washer (21), capscrew (20), and locknut (19)	Position Install and tighten	

NOTE

To complete installation of accelerator cable (11) install two new tie straps and secure accelerator cable to radiator brace.

ADJUSTMENTS

20	Engine governor housing	a. Ball joint (6)	Adjust	Check that ball joint engages cable (11) shaft a minimum of 1/4 inch. If not adjust for minimum 1/4 inch engagement
		b. Throttle arm (34)	Rotate	Clockwise to full open position

2-13. FUEL SYSTEM MAINTENANCE (CONT)

e. Accelerator and Throttle Linkage (cont).

STEP	LOCATION	ITEM	ACTION	REMARKS
ADJUSTMENTS (cont)				
20 (cont)		c. Nut (23)	Adjust	With throttle arm (34) in full open position, adjust so that bracket (7) will move away from capscrew (20) approximately 1/16 inch before it stops
		d. Throttle arm (34)	Release	
21	Cab side	e. Nut (22) a. Ball joint (41)	Tighten Adjust	Against bracket (7) Check that ball joint engages cable (11) shaft a minimum of 1/4 inch. If not adjust for minimum 1/4 inch engagement
22	Cab interior	b. Cab a. Pedal assembly (10)	Lower Depress	To normal operating position Depress until throttle arm (34) is in the full open position
		b. Capscrew (64)	Turn	Counterclockwise until bottom of depressed pedal assembly (10) contacts top of capscrew
		c. Nut (65)	Tighten	Locks adjustment

NOTE

Pedal assembly adjustment is correct when pedal assembly (10) is contacting capscrew (64) with throttle arm (34) in full throttle position.

2-14. EXHAUST SYSTEM MAINTENANCE

a. Exhaust Pipes.

This task covers:

- a. Removal
- b. Cleaning

- c. Inspection
- d. Installation

INITIAL SETUP

Tools

No. 1 Common Organizational Maintenance Tool Kit

- Adjustable open end wrench
- Socket wrench set
- Scratch wire brush
- Safety glasses

Welding shop equipment
Grinder, portable

Personnel Required

Wheel Vehicle Mechanic MOS 63B

Equipment Condition
Paragraph Condition Description

Parked on level surface,
engine off, and parking brake
applied.
Cab tilted 45 degrees.
Muffler removed.

2-14b

Materials/Parts

Cleaning solvent Item 1, Appendix C
Clean cloths Item 2, Appendix C
Penetrating oil Item 44, Appendix C

STEP	LOCATION	ITEM	ACTION	REMARKS
------	----------	------	--------	---------

REMOVAL

1	Engine, right side	a. Clamp (1)	a. Loosen nut	
		b. Two nuts (2) and lock washers (3)	b. Remove	
		c. U-bolt (4) and clamp (5)	Remove	
		d. Two nuts (6) and lock washers (7)	Remove	
		e. U-bolt (8) and clamp (9)	Remove	
		f. Exhaust pipe (10)	Remove	
		g. Two capscrews (11), lock washers (12), and bracket (13)	Remove	Only if bracket (13) is to be replaced or engine is to be removed
2	Tractor, right side	a. Two nuts (14) and lock washers (15)	Remove	

2-14. EXHAUST SYSTEM MAINTENANCE (CONT)

a. Exhaust Pipes (cont).

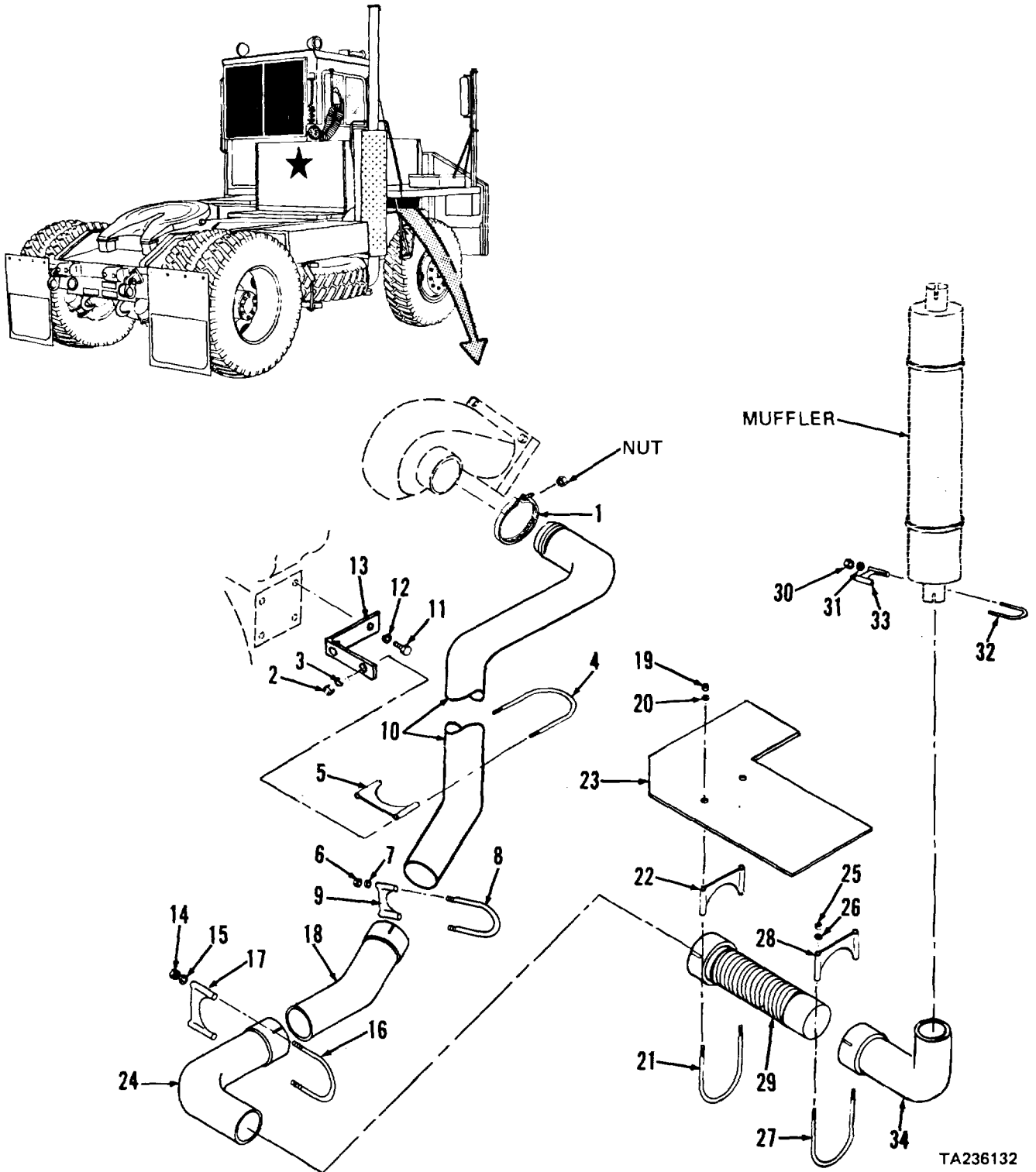

TA236132

2-14. EXHAUST SYSTEM MAINTENANCE (CONT)

a. Exhaust Pipes (cont).

KEY

- | | | |
|----------------------|----------------------|----------------------|
| 1. Clamp | 13. Bracket | 24. Elbow |
| 2. Nuts (2) | 14. Nuts (2) | 25. Nuts (2) |
| 3. Lock washers (2) | 15. Lock washers (2) | 26. Lock washers (2) |
| 4. U-bolt | 16. U-bolt | 27. U-bolt |
| 5. Clamp | 17. Clamp | 28. Clamp |
| 6. Nuts (2) | 18. Elbow | 29. Flex pipe |
| 7. Lock washers (2) | 19. Nuts (2) | 30. Nuts (2) |
| 8. U-bolt | 20. Lock washers (2) | 31. Lock washers (2) |
| 9. Clamp | 21. U-bolt | 32. U-bolt |
| 10. Exhaust pipe | 22. Clamp | 33. Clamp |
| 11. Capscrews (2) | 23. Heat shield | 34. Elbow |
| 12. Lock washers (2) | | |

STEP	LOCATION	ITEM	ACTION	REMARKS
REMOVAL (cont)				
2 (cont)		b. U-bolt (16), clamp (17), and elbow (18)	Remove	
		c. Two nuts (19) and lock washers (20)	Remove	
		d. U-bolt (21), clamp (22), heat shield (23), and elbow (24)	Remove	
		e. Two nuts (25) and lock washers (26)	Remove	
		f. U-bolt (27), clamp (28), and flex pipe (29)	Remove	
		g. Two nuts (30) and lock washers (31)	Remove	
		h. U-bolt (32) and clamp (33)	Remove	
		i. Elbow (34)	a. Remove tack welds b. Remove elbow	Grind tack welds off From bottom of muffler

2-14. EXHAUST SYSTEM MAINTENANCE (CONT)

a. Exhaust Pipes (cont).

STEP	LOCATION	ITEM	ACTION	REMARKS
------	----------	------	--------	---------

CLEANING

WARNING

Dry cleaning solvent (P-D-680), used to clean parts is toxic and flammable. Wear protective goggles and gloves and use only in a well ventilated area. Avoid contact with skin, eyes, and clothes and don't breathe vapors. Do not use near open flame or excessive heat and don't smoke when using it. Failure to do so could cause serious injury. If you become dizzy while using cleaning solvent, get fresh air and medical attention immediately. If contact with skin or clothes is made, flush with large amounts of water. If contact with eyes is made, wash eyes with water and seek medical aid immediately. Compressed air must not exceed 30 psi. Wear safety glasses when drying parts with compressed air. Failure to do so could cause serious injury to eyes and possible blindness. If you hurt your eyes or if a foreign object is blown into your eyes, seek medical attention immediately.

3		All parts	Clean	Use cleaning solvent P-D-680. Dry thoroughly with compressed air at 30 psi. Remove rust with stiff wire brush
---	--	-----------	-------	---

INSPECTION

4		All parts	Inspect	Replace if cracked, damaged, worn, dented or threads damaged
---	--	-----------	---------	--

INSTALLATION

5	Tractor, right side	a. Elbow (34) b. Clamp (33) c. U-bolt (32), lock washers (31), and nuts (30) d. Flex pipe (29)	Install Position Install and tighten	On base of muffler
			Install	In elbow (34)

2-14. EXHAUST SYSTEM MAINTENANCE (CONT)

a. Exhaust Pipes (cont).

STEP	LOCATION	ITEM	ACTION	REMARKS
INSTALLATION (cont)				
5 (cont)		e. Clamp (28)	Position	
		f. U-bolt (27), two lock washers (26), and nuts (25)	Install and tighten	
		g. Elbow (24)	Install	In flex pipe (29)
		h. Heat shield (23) and clamp (22)	Position	
		i. U-bolt (21), two lock washers (20) and nuts (19)	Install and tighten	
		j. Elbow (18)	Install	In elbow (24)
		k. Clamp (17)	Position	
		l. U-bolt (16), two lock washers (15), and nuts (14)	Install and tighten	
		6	Engine, right side	a. Bracket (13)
b. Two lock wash- ers (12) and capscrews (11)	Install and tighten			
c. Exhaust pipe (10)	Install			In elbow (18)
d. Clamp (9)	Position			
e. U-bolt (8), two lock washers (7), and nuts (6)	Install and tighten			
f. Clamp (5)	Position			
g. U-bolt (4), two lock washers (3), and nuts (2)	Install and			tighten
h. Clamp (1)	Install and			
i. Elbow (34)	Tack weld			To muffler in three opposite places

2-14. EXHAUST SYSTEM MAINTENANCE (CONT)

b. Muffler and Exhaust Stack.

This task covers:

- a. Removal
- b. Cleaning

- c. Inspection
- d. Installation

INITIAL SETUP

Tools

- No. 1 Common Organizational Maintenance Tool Kit
- Adjustable open end wrench
- Socket wrench set
- Scratch wire brush
- Safety glasses

Personnel Required

Wheel Vehicle Mechanic MOS 63B

Equipment Condition

Paragraph Condition Description

Parked on level surface, engine off, and parking brake applied.

Materials/Parts

- Cleaning solvent Item 1, Appendix C
- Clean cloths Item 2, Appendix C
- Penetrating oil Item 44, Appendix C

2-14a Clamp and elbow at bottom of muffler removed.

STEP	LOCATION	ITEM	ACTION	REMARKS
------	----------	------	--------	---------

REMOVAL

1	Tractor, right side	a. Two nuts (1), lock washers (2) and cap-screws (3)	Remove	
		b. Tailpipes (4 and 5)	Separate	
		c. Eight locknuts (6), cap-screws (7), and two hinge halves (8)	Remove	
		d. Nut (9), cap-screw (10), and rain cap (11)	Remove	
		e. Six screws (16) and cage (17)	Remove	
		f. Two nuts (12) and lock washers (13)	Remove	
		g. U-bolt (14), clamp (15), and tailpipe (5)	Remove	

2-14. EXHAUST SYSTEM MAINTENANCE (CONT)

b. Muffler and Exhaust Stack (cont).

KEY

- 1 Nuts (2)
- 2 Lock washers (2)
- 3 Capscrews (2)
- 4 Tailpipe
- 5 Tailpipe
- 6 Lock nuts (8),
- 7 Capscrews (8)
- 8 Hinge halves (2)
- 9 Nut
- 10 Capscrew
- 11 Rain cap
- 12 Nuts (2)
- 13 Lock washers (4)
- 14 U-bolt
- 15 Clamp
- 16 Screws (6)
- 17 Cage
- 18 Muffler
- 19 Bracket
- 20 Nuts
- 21 Capscrews (2)
- 22 Clamps (2)
- 23 Capscrews (4)
- 24 Nuts (4)
- 25 Locknuts (4)
- 26 Washers (4)
- 27 Capscrews (4)
- 28 Bracket

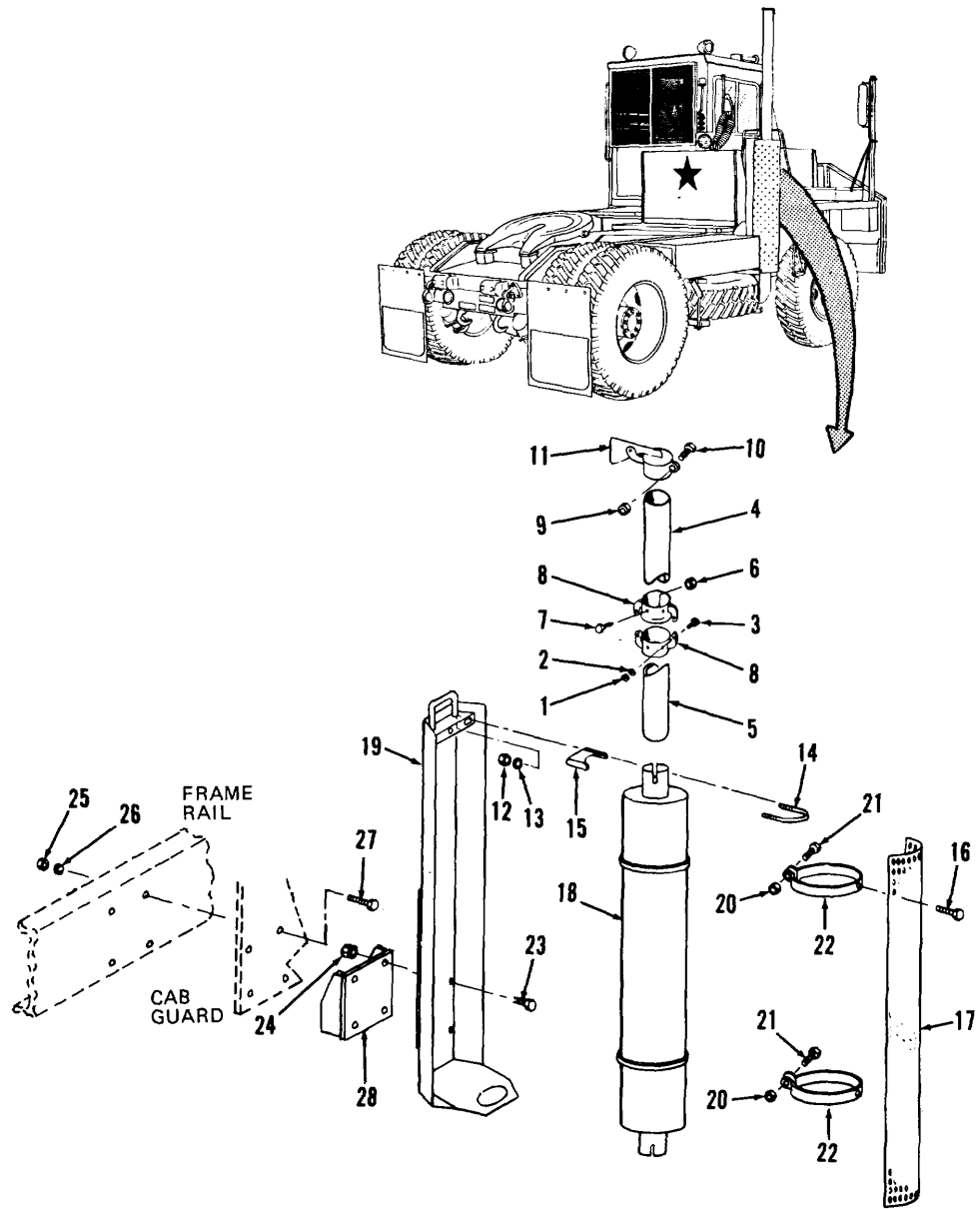

2-14. EXHAUST SYSTEM MAINTENANCE (CONT)

b. Muffler and Exhaust Stack (cont).

STEP	LOCATION	ITEM	ACTION	REMARKS
REMOVAL (cont)				
1 (cont)		h. Muffler (18)	Remove	From bracket (19)
		i. Two nuts (20) and capscrews (21)	Remove	From clamps (22)
		j. Two clamps (22)	Remove	
		k. Four capscrews (23), nuts (24), and bracket (19)	Remove	From bracket (26)
		l. Rear cab guard	Support	On right side
	m. Four locknuts (25), washers (26), and capscrews (27)	Remove	Support bracket (28)	

NOTE

Two shims may fall on ground when capscrews (27) are removed. Retain shims for installation.

CLEANING		n. Bracket (28)	Remove	From rear cab guard
----------	--	-----------------	--------	---------------------

WARNING

Dry cleaning solvent (P-D-680), used to clean parts is toxic and flammable. Wear protective goggles and gloves and use only in a well ventilated area. Avoid contact with skin, eyes, and clothes and don't breathe vapors. Do not use near open flame or excessive heat and don't smoke when using it. Failure to do so could cause serious injury. If you become dizzy while using cleaning solvent, get fresh air and medical attention immediately. If contact with skin or clothes is made, flush with large amounts of water. If contact with eyes is made, wash eyes with water and seek medical aid immediately.

Compressed air must not exceed 30 psi. Wear safety glasses when drying parts with compressed air. Failure to do so could cause serious injury to eyes and possible blindness. If you hurt your eyes or if a foreign object is blown into your eyes, seek medical attention immediately.

2-14. EXHAUST SYSTEM MAINTENANCE (CONT)

b. Muffler and Exhaust Stack (cont).

STEP	LOCATION	ITEM	ACTION	REMARKS
CLEANING (cont)				
2		All parts	Clean	Use cleaning solvent P-D-680. Dry thoroughly with compressed air at 30 psi. Remove rust with stiff wire brush
INSPECTION				
3		All parts	Inspect	Replace if cracked, damaged, worn, dented, or threads damaged
INSTALLATION				
4	Tractor, right side	a. Bracket (28)	Position	Align mounting holes with holes in rear cab guard and frame rail
		b. Two capscrews (27)	Install	In bottom holes
		c. Lower shim	Install	Para 2-65d
		d. Two capscrews (27)	Install	In top holes
		e. Upper shim	Install	Para 2-65d
		f. Four washers (26) and locknuts (25)	Install and tighten	
		g. Rear cab guard support	Remove	From right side
		h. Bracket (19)	Position	On bracket (28)
		i. Four capscrews (23) and nuts (24)	Install and tighten	
		j. two clamps (22)	Position	On muffler (18)
		k. Cage (17)	Position	
		l. Six screws (16)	Install and tighten	
		m. Two capscrews (21) and nuts (20)	Install and tighten	
		n. Muffler (18)	Install	In bracket (19)
		o. Rain cap (11)	Position	On tailpipe (4)
		p. Capscrew (10) and nut (9)	Install and tighten	

2-14. EXHAUST SYSTEM MAINTENANCE (CONT)

b. Muffler and Exhaust Stack (cont).

STEP	LOCATION	ITEM	ACTION	REMARKS
INSTALLATION (cont)				
4 (cont)		q. One hinge half (8)	Position	On tailpipe (4)
		r. Four capscrews (7) and nuts (6)	Install and tighten	
		s. One hinge half (8)	Position	On tailpipe (5)
		t. Four capscrews (7) and nuts (6)	Install and tighten	
		u. Tailpipe (5)	Install	On muffler (18)
		v. Clamp (15)	Position	
		w. U-bolt (14), two washers (13), and nuts (12)	Install and tighten	
		x. Tailpipes (4 and 5)	Connect	
	y. Two capscrews (3), lock washers (2), and nuts (1)	Install and tighten		
	z. Muffler (18)	Connect	To elbow; para 2-14a	

2-15. COOLING SYSTEM MAINTENANCE

a. Radiator.

(1) Servicing. This task covers servicing of the radiator consisting of checking coolant level, draining coolant, flushing, and filling the radiator with coolant.

INITIAL SETUP:

Tools

No. 1 Common Organizational Maintenance Tool Kit

- Socket wrench set
- Adjustable open end wrench
- Safety glasses

Flushing gun

Materials/Parts

- Antifreeze, ethylene glycol Item 25, Appendix C
- Hose, 1-3/4 inch inside diameter
- 15 gallon container

Personnel Required

Wheel Vehicle Mechanic MOS 63B

Equipment Condition

Paragraph Condition Description

Vehicle parked on level surface, engine off, parking brake applied, and hood open.

STEP	LOCATION	ITEM	ACTION	REMARKS
COOLANT LEVEL CHECK				
1	Radiator	Reservoir tank	Check coolant level	If tank is empty, proceed to step 2 below
2	Cab	a. Radiator access panel	Unlatch and raise	

WARNING

Remove radiator cap slowly to relieve pressure before completely removing when engine is hot. Failure to do so could cause severe injury. If you are scalded by steam, obtain medical attention immediately.

- b. Radiator cap
Loosen, then remove
Turn counterclockwise to first detent. Allow pressure to escape before removing

2-15 COOLING SYSTEM MAINTENANCE (CONT)

a. Radiator (cont).

(1) Servicing (cont).

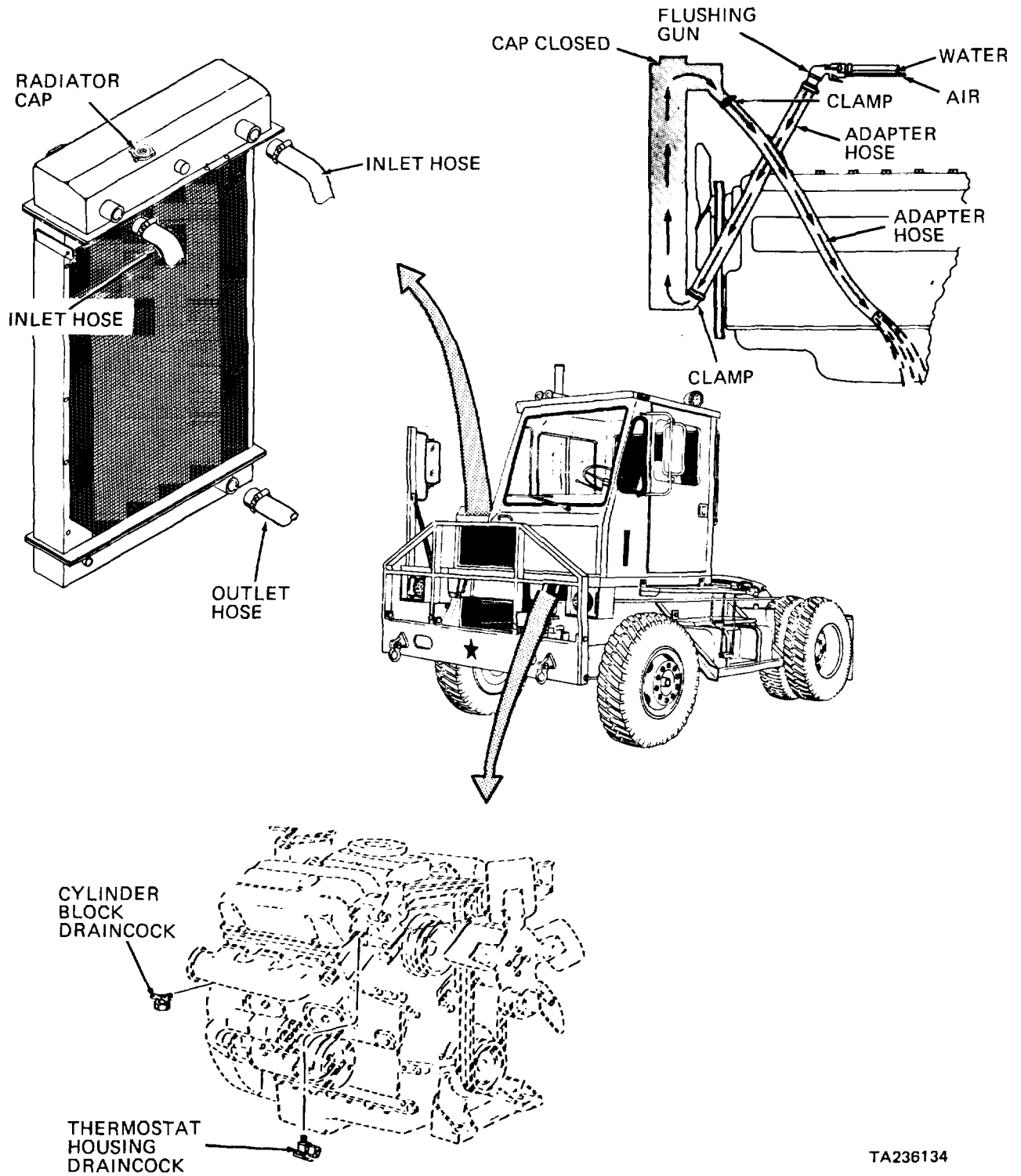

TA236134

2-15. COOLING SYSTEM MAINTENANCE (CONT)

- a. Radiator (cont).
- (1) Servicing (cont).

STEP	LOCATION	ITEM	ACTION	REMARKS
------	----------	------	--------	---------

COOLANT LEVEL CHECK (cont)

2
(cont)

CAUTION

If coolant is hot do not add coolant to radiator unless engine is running. Allow engine to run for several minutes to enable coolant being added to mix and circulate. Failure to observe this precaution may cause engine damage.

		c. Radiator	Fill	Use solution of 50 percent water and 50 percent ethylene glycol. Fill to two inches below level of radiator cap opening Rotate fully clockwise
		d. Radiator cap	Install	
		e. Radiator access panel	Close and latch	
		f. Hood	Close	

DRAINING RADIATOR

WARNING

Allow radiator and cooling system to cool prior to draining coolant. Hot coolant can cause scalding and severe burns. If you are injured, obtain medical aid immediately.

3	Cab	a. Hood	Raise
		b. Radiator access panel	Raise

WARNING

Remove radiator cap slowly to relieve pressure before completely removing when engine is hot. Failure to do so could cause severe injury. If you are scalded by steam, obtain medical attention immediately.

2-15. COOLING SYSTEM MAINTENANCE (CONT)

- a. Radiator (cont).
- (1) Servicing (cont).

STEP	LOCATION	ITEM	ACTION	REMARKS
DRAINING RADIATOR (cont)				
4	Radiator, top	Radiator cap	Loosen, then remove	Turn counterclockwise to first detent. Allow pressure to escape before removing
5	Radiator, bottom	a. 15 gallon container	Position	Under drain cock to drain coolant into
		b. Drain cock	Open	

FLUSHING COOLING SYSTEM

NOTE

Perform steps 3 through 5 above if not already performed.

6	Engine	a. 15 gallon container	Position	Under cylinder block drain cocks Drain coolant into container When all coolant is drained
		b. Cylinder block drain cocks	Open	
		c. Cylinder block drain cocks	Close	
		d. Radiator drain cock	Close	
7	Cab tilt pump	Cab	Tilt 45 degrees	
8	Radiator, top rear and bottom rear	a. Inlet and outlet hoses	Disconnect	To inlet and outlet connections on radiator To adapter hose connected to outlet connection on radiator With water
		b. Long adapter hoses	Connect	
		c. Flushing gun	Connect	
		d. Radiator	Fill	
		e. Radiator cap	Install	

2-15. COOLING SYSTEM MAINTENANCE (CONT)

- a. Radiator (cont).
- (1) Servicing (cont).

STEP	LOCATION	ITEM	ACTION	REMARKS
------	----------	------	--------	---------

FLUSHING COOLING SYSTEM (cont)

8
(cont)

CAUTION

Apply air pressure gradually to prevent damage to radiator. Don't use air pressure greater than 30 psi.

f. Flushing gun			Operate	Shut off water supply and blow water out of radiator with air. Repeat steps 8d through 8f as often as necessary until flushing stream runs clear
g. Flushing gun and adapter hoses			Disconnect	
h. Inlet and outlet hoses			Connect	To inlet and outlet connections on radiator

WARNING

Compressed air must not exceed 30 psi. Wear safety glasses when cleaning parts with compressed air. Failure to do so could cause serious injury to eyes and possible blindness. If you hurt your eyes or if a foreign object is blown into your eyes, seek medical attention immediately.

i. Radiator			Clean	Use compressed air to clean exterior and to remove foreign matter obstructing passage of air through radiator
-------------	--	--	-------	---

FILLING COOLING SYSTEM

9	Radiator, top	Radiator fill	Fill	Use solution of 50 percent water and 50 percent ethylene glycol. Cooling system capacity is 50 quarts. Fill with coolant solution to two inches below level of radiator cap opening
---	---------------	---------------	------	---

2-15. COOLING SYSTEM MAINTENANCE (CONT)

a. Radiator (cont).

(1) Servicing (cont).

STEP	LOCATION	ITEM	ACTION	REMARKS
FILLING COOLING SYSTEM (cont)				
10 position	Vehicle	Cab		Lower To normal driving
11	Cab	Start switch	Start engine	
12	Radiator, top	a. Coolant b. Radiator cap	Watch level Install	Add coolant as necessary Turn clockwise to install
13	Cab	Key switch	Turn engine off	
14	Vehicle, bottom	Containers	Remove	Discard coolant solution
15	Cab	a. Radiator access panel b. Hood	Close and latch Close	

2-15. COOLING SYSTEM MAINTENANCE (CONT)

a. Radiator (cont).

(2) Testing. This task covers pressure testing the radiator.

INITIAL SETUP:

Tools

No. 1 Common Organizational Maintenance Tool Kit
 Socket wrench set
 Adjustable open end wrench
 Pressure tester
 Cap adapter

Personnel Required

Wheel Vehicle Mechanic MOS 63B

Equipment Condition

Paragraph Condition Description

Parked on level surface;
 parking brake applied; engine warm and turned off.
 Cab tilted 45 degrees.

Materials/Parts

Clean cloths Item 2, Appendix C
 Antifreeze Item 25, Appendix C
 Two five gallon containers
 Five C-clamps
 Ten wooden blocks

STEP	LOCATION	ITEM	ACTION	REMARKS
------	----------	------	--------	---------

TESTING

NOTE

With engine at normal operating temperature, run engine at high speed for two minutes, and return to idle speed.

WARNING

Remove radiator cap slowly to relieve pressure before completely removing when engine is hot. Failure to follow this procedure could cause severe injury. If you are scalded by steam, seek medical aid immediately.

1	Radiator, top	Radiator cap	Rotate counter-clockwise	To first detent. A hissing from cap and filler neck indicates that system is pressurized
2	Instrument panel	Engine	Turn off	Allow engine to cool

2-15. COOLING SYSTEM MAINTENANCE (CONT)

- a. Radiator (cont).
- (2) Testing (cont).

STEP	LOCATION	ITEM	ACTION	REMARKS
------	----------	------	--------	---------

TESTING (cont)

3	Radiator, top	a. Radiator cap	a. Remove b. Rinse c. Install	With clear water On cap adapter and pressure tester
---	---------------	-----------------	-------------------------------------	--

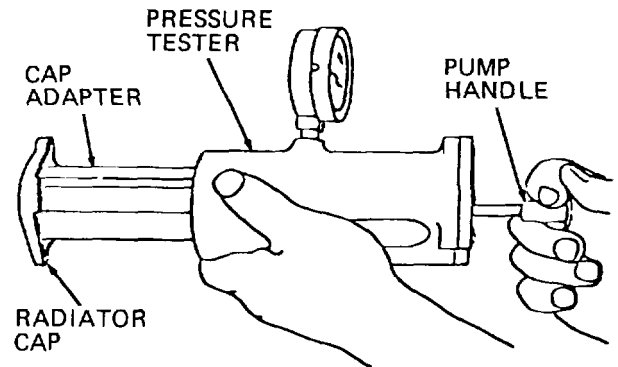

TA126864

NOTE

It may be necessary to reinstall radiator cap several times to ensure tight seal.

		b. Pressure tester pump		Operate and watch meter reading at its highest point. Cap release pressure should be 6 to 9 pounds, and should remain steady for at least 30 seconds. If radiator cap pressure is 6 to 9 pounds, and remains steady for at least 30 seconds before dropping, proceed to step c below. If radiator cap pressure is not 6 to 9 pounds or if pressure drops rapidly, install new radiator cap
		c. Radiator cap and cap adapter	Disconnect	From pressure tester
4	Radiator, bottom	a. Container b. Drain cock	Position Open	Under drain cock

2-15. COOLING SYSTEM MAINTENANCE (CONT)

- a. Radiator (cont).
- (2) Testing (cont).

STEP	LOCATION	ITEM	ACTION	REMARKS
TESTING (cont)				
5	Engine	Coolant hoses	a. Disconnect at engine b. Clamp	Para 2-15c Attach two blocks of wood and one C-clamp to the end of each hose and clamp shut
6	Transmission	a. Container b. Transmission cooling lines	Position Disconnect	Under hoses Para 2-41e
7	Radiator, top	a. Radiator filler neck b. Pressure tester	Fill a. Attach b. Press down c. Operate pump d. Observe meter e. Remove	With coolant To radiator filler neck, with locking ears in line with entrance notches of filler neck On tester, and rotate clockwise until locking ears are stopped by lugs on radiator filler neck Until meter indicates 9 pounds pressure a. If pressure holds steady for 2 or more minutes, radiator is okay b. If pressure drops slowly, radiator has seepage or slight leakage. Repair, or install new radiator (notify direct support maintenance) c. If pressure drops quickly, radiator has serious leakage. Repair, or install new radiator (notify direct support maintenance) Rotate counterclockwise to remove from radiator filler neck

2-15. COOLING SYSTEM MAINTENANCE (CONT)

- a. Radiator (cont).
- (2) Testing (cont).

STEP	LOCATION	ITEM	ACTION	REMARKS
TESTING (cont)				
8	Radiator, bottom	a. Container b. Drain cock	Position Open	Under drain cock
9	Radiator hoses	a. C-clamps b. Radiator hoses c. Transmission cooling lines	Remove Connect Connect	Remove C-clamps one at a time. Connect hoses to engine and transmission as soon as C-clamp for that particular hose is removed; then tighten hose clamp securely Para 2-15c Para 2-41e
10	Radiator, top	Radiator	Fill	Para 2-15a(1)
11	Cab tilt pump	Cab	Lower	To normal operating position
12	Engine compartment	Transmission	Fill	Para 2-41b
13	Cab	Engine	Start and operate	
14	Engine compartment	a. Radiator b. Transmission dipstick	Check coolant level Check level	Para 2-15a(1); add as necessary Para 2-41b; add as necessary
15	Cab	Engine	Turn off	
16	Vehicle, bottom	Containers	Remove	Discard used coolant and oil properly

2-15. COOLING SYSTEM MAINTENANCE (CONT)

b. Coolant Filter.

(1) Servicing. This task covers coolant filter element replacement.

INITIAL SETUP:

Tools

Strap type oil filter wrench

Equipment Condition

Paragraph Condition Description

Materials/Parts

Antifreeze Item 25, Appendix C
 Filter element FSCM 59549 PN PFC-22

2-65c

Parked on level surface;
 parking brake applied; engine
 off.
 Rear platform removed.

Personnel Required

Wheel Vehicle Mechanic MOS 63B

STEP	LOCATION	ITEM	ACTION	REMARKS
------	----------	------	--------	---------

SERVICING

WARNING

Remove radiator cap slowly to relieve pressure before completely removing when engine is hot. Failure to follow this procedure could cause severe injury. If you are scalded by steam, seek medical aid immediately.

1	Radiator, top	Radiator cap	Remove	Rotate counterclockwise
2	Radiator, bottom	Drain cock	Open	Drain radiator
3	Engine	Cylinder block drain cocks	Open	Drain cooling system
4	Rail, behind cab guard	Coolant filter element	a. Remove and discard b. Install new element	Use filter wrench, -turn counterclockwise to remove Install until gasket contacts base; then turn one-half of a turn to obtain proper seal
5	Engine	Cylinder block drain cocks	Close	Tighten securely
6	Radiator, bottom	Drain cock	Close	Tighten securely
7	Radiator, top	Radiator	Fill	Para 2-15a(l)
8	Behind cab guard	Rear platform	Install	Para 2-65c

2-15. COOLING SYSTEM MAINTENANCE (CONT)

- b. Coolant Filter (cont).
- (1) Servicing (cont).

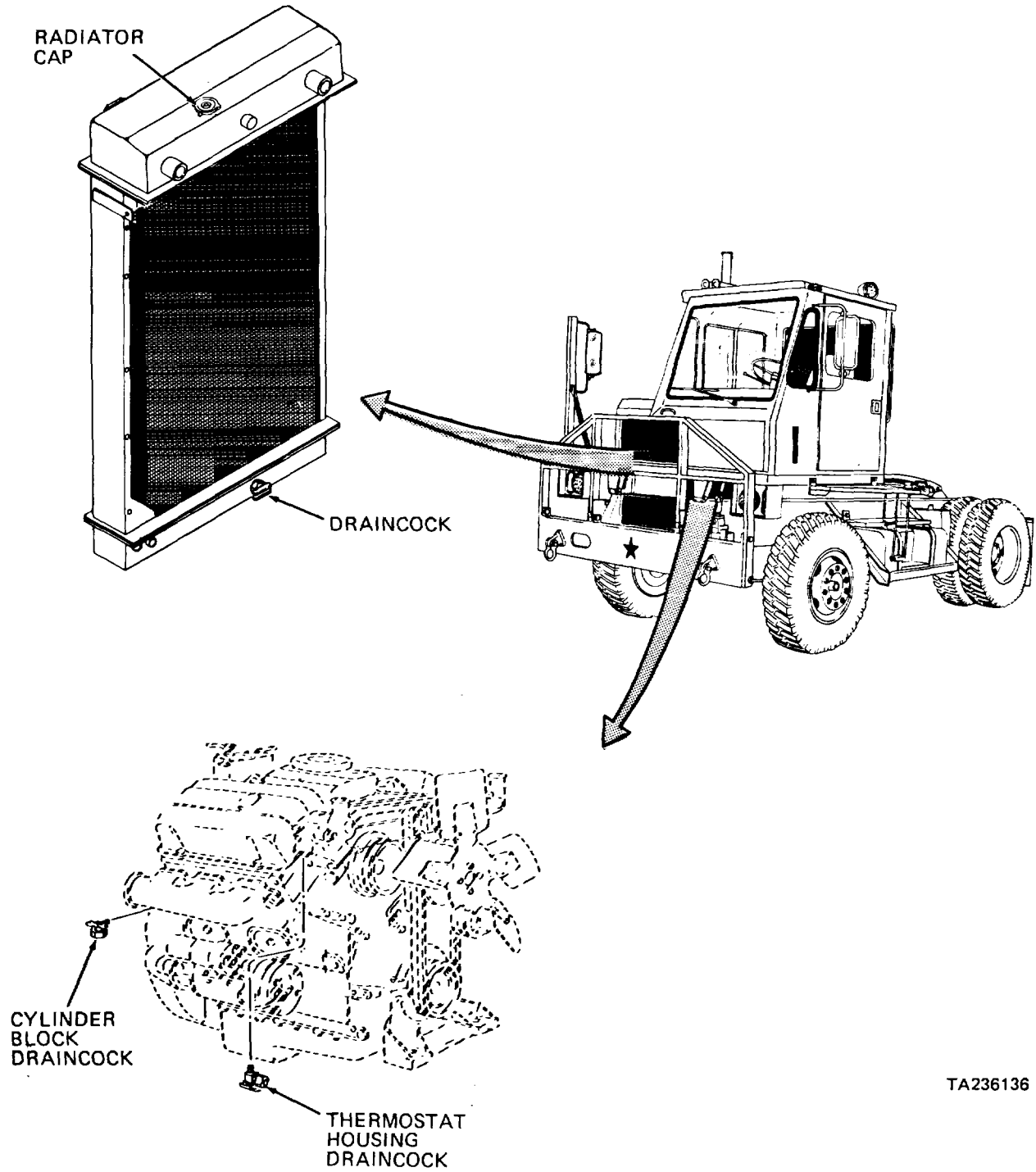

TA236136

2-15. COOLING SYSTEM MAINTENANCE (CONT)

- b. Coolant Filter (cont).
- (1) Servicing (cont).

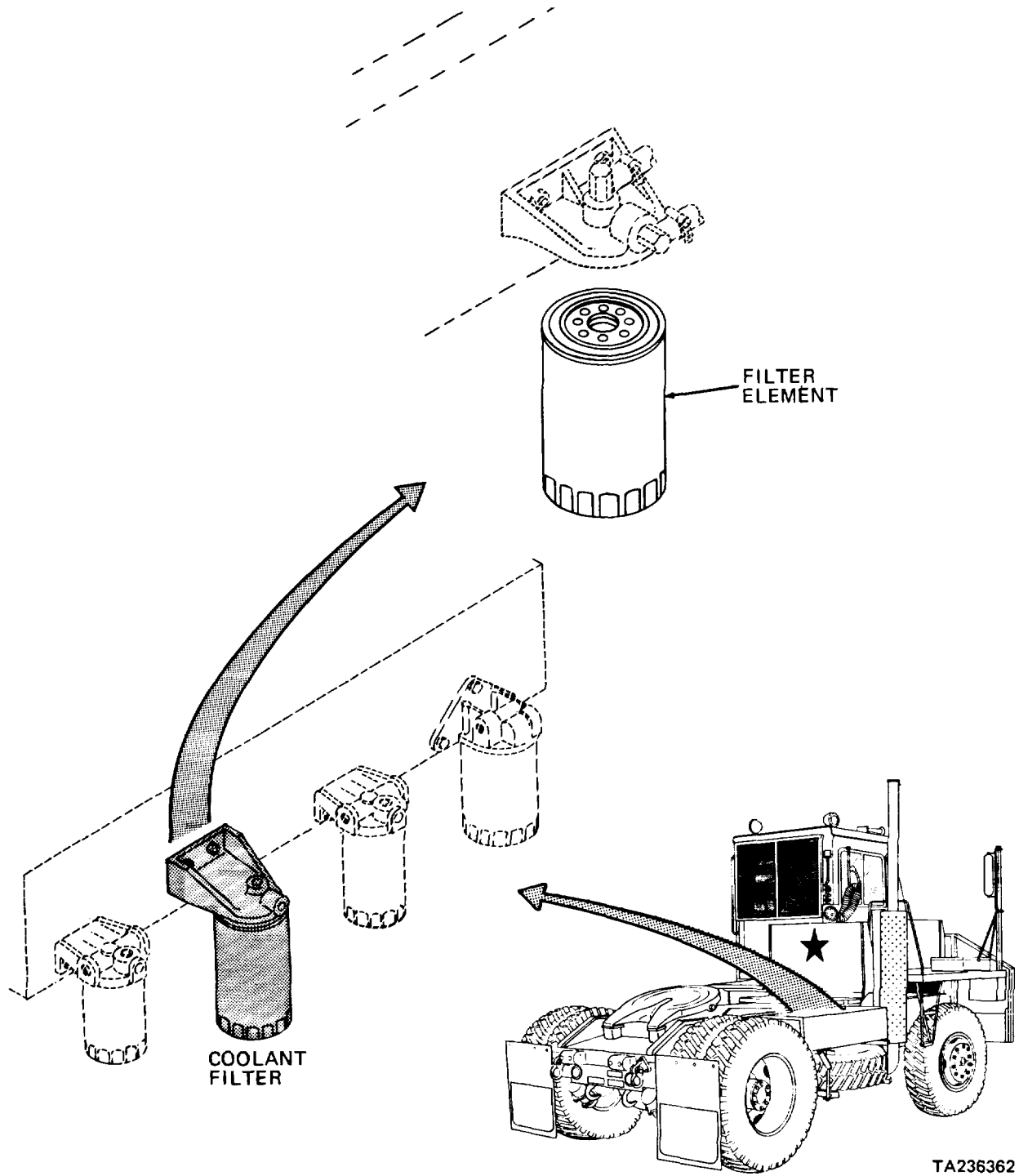

2-15. COOLING SYSTEM MAINTENANCE (CONT)

b. Coolant Filter (cont).

(2) Removal.

This task covers: a. Removal c. Inspection
 b. Cleaning d. Installation

INITIAL SETUP:

Tools

No. 1 Common Organizational Maintenance
 Tool Kit

- Adjustable open end wrench
- Socket wrench set
- Safety glasses

Personnel Required

Wheel Vehicle Mechanic MOS 63B

Equipment Condition

Paragraph Condition Description

Materials/Parts

Cleaning

- solvent Item 1, Appendix C
- Clean cloths Item 2, Appendix C
- Antifreeze Item 25, Appendix C
- Detergent Item 27, Appendix C
- Teflon tape Item 43, Appendix C
- Coolant filter FSCM 59549 PN PFC22
- Four tie straps FSCM 96906 PN MS3667-1-9

Parked on level surface;
 parking brake applied; engine
 off.
 Cab tilted 45 degrees.
 2-65c Rear platform removed.
 2-15b(l) Cooling system drained;
 radiator and engine drain
 cocks open; coolant filter
 element removed.

STEP	LOCATION	ITEM	ACTION	REMARKS
------	----------	------	--------	---------

REMOVAL

1	Engine, right side	a. Clamp (2)	Loosen	
		b. Hose (3)	Remove	Pull from connector (4)
		c. Connector (4)	Remove	
		d. Bushing (5)	Remove	
		e. Clamp (6)	Loosen	
		f. Hose (7)	Remove	Pull from fitting (8)
		g. Fitting (8)	Remove	
		h. Pipe plug (9)	Remove	
		i. Tie strap (1)	Cut, remove and discard	Note location for installa- tion
2	Rail, behind cab guard	a. Clamp (10)	Loosen	
		b. Hose (7)	Remove	Pull from connector (11)
		c. Connector (11)	Remove	
		d. Clamp (12)	Loosen	
		e. Hose (3)	Remove	Pull from connector (13)
		f. Connector (13)	Remove	

2-15. COOLING SYSTEM MAINTENANCE (CONT)

- b. Coolant Filter (cont).
- (2) Removal (cont).

KEY

- 1. Tie strap
- 2. Clamp
- 3. Hose
- 4. Connector
- 5. Bushing
- 6. Clamp
- 7. Hose
- 8. Fitting
- 9. Pipe plug
- 10. Clamp
- 11. Connector
- 12. Clamp
- 13. Connector
- 14. Locknuts (2)
- 15. Capscrews (2)
- 16. Filter head
- 17. Tie straps (2)
- 18. Protective hose
- 19. Tie strap

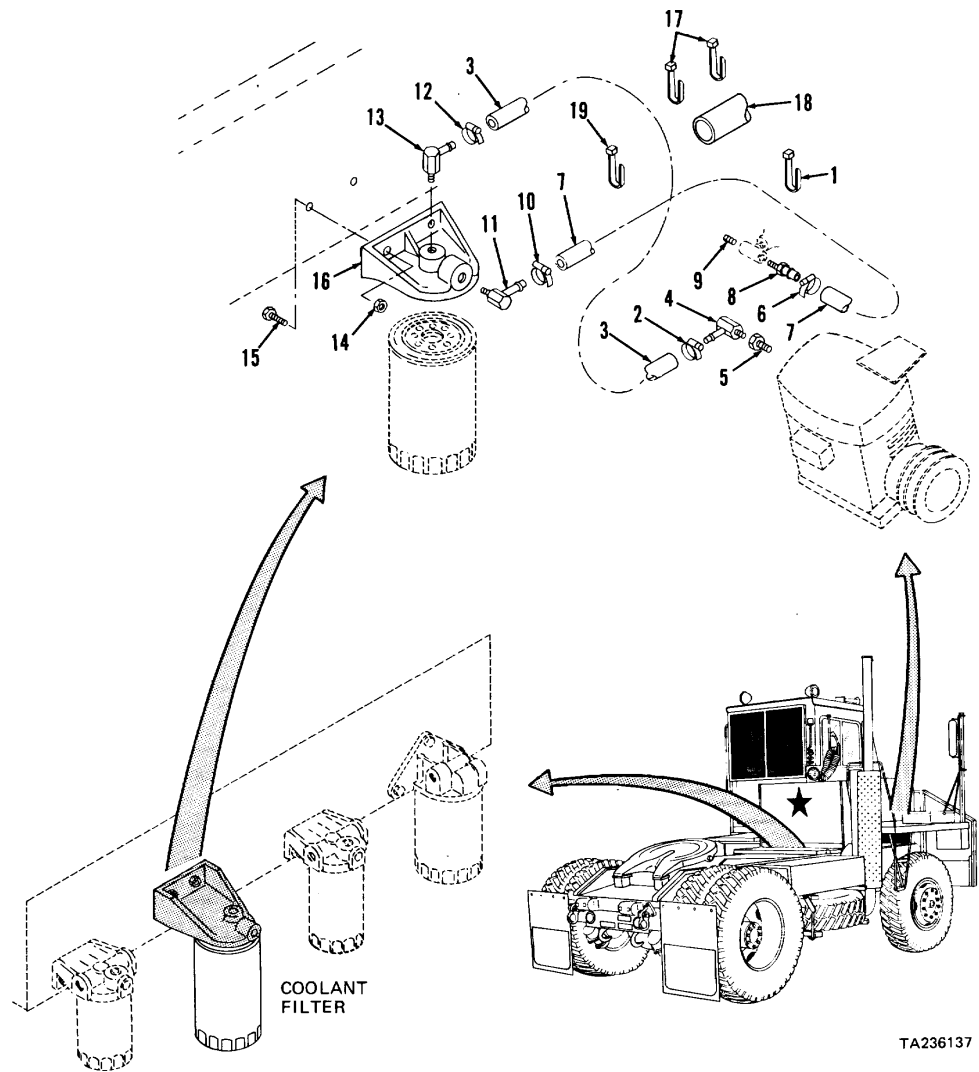

TA236137

2-15. COOLING SYSTEM MAINTENANCE (CONT)

- b. Coolant Filter (cont).
 (2) Removal (cont).

STEP	LOCATION	ITEM	ACTION	REMARKS
REMOVAL (cont)				
2 (cont)		g. Clamps (2, 6, 10, and 12)	Remove from hoses	
		h. Three tie straps (17 and 19)	Cut, remove and discard	Note locations for installation
		i. Protective hose (18)	Remove	From hoses (3 and 7)
		j. Two locknuts (14), cap-screws (15), and filter head (16)	Remove	
		k. Hoses (3 and 7)	Remove	From tractor
CLEANING				
3		a. Hoses (3 and 7)	Clean	Use clean cloth moistened with mild detergent solution

WARNING

Dry cleaning solvent (P-D-680), used to clean parts is toxic and flammable. Wear protective goggles and gloves and use only in a well ventilated area. Avoid contact with skin, eyes, and clothes and don't breathe vapors. Do not use near open flame or excessive heat and don't smoke when using it. Failure to do so could cause serious injury. If you become dizzy while using cleaning solvent, get fresh air and medical attention immediately. If contact with skin or clothes is made, flush with large amounts of water. If contact with eyes is made, wash eyes with water and seek medical aid immediately.

Compressed air must not exceed 30 psi. Wear safety glasses when drying parts with compressed air. Failure to do so could cause serious injury to eyes and possible blindness. If you hurt your eyes or if a foreign object is blown into your eyes, seek medical attention immediately.

2-15. COOLING SYSTEM MAINTENANCE (CONT)

- b. Coolant Filter (cont).
- (2) Removal (cont).

STEP	LOCATION	ITEM	ACTION	REMARKS
CLEANING (cont)				
3 (cont)		b. All other parts	Clean	Use cleaning solvent P-D-680. Dry with compressed air
INSPECTION				
4		a. Hoses and fittings	Inspect	Replace if cracked, split, or holes are apparent. Check inside diameter for blockage; clear blockage or replace part
		b. All other parts	Inspect	Replace if damaged or cracked or if threads are damaged
INSTALLATION				
5	Rail, behind cab guard	a. Filter head (16)	Position	On rail; align mounting holes
		b. Two capscrews (15) and locknuts (14)	Install and tighten	Secures filter head (16)
		c. Hoses (3 and 7)	Route	
		d. Protective hose (18)	Position	Over hoses (3 and 7)
		e. Connector (11)	a. Tape b. Install	Wrap threads with Teflon tape
		f. Clamp (10)	Install	On hose (7)
		g. Hose (7)	Connect	To connector (11); tighten clamp (10)
		h. Connector (13)	a. Tape b. Install	Wrap threads with Teflon tape
		i. Clamp (12)	Install	On hose (3)
		j. Hose (3)	Connect	To connector (13); tighten clamp (12)
		k. New tie strap (19)	Install	Around hoses (3 and 7) at location noted during removal
		l. Two new tie	Install	Around protective hose (18) straps (17) at locations noted during removal

2-15. COOLING SYSTEM MAINTENANCE (CONT)

b. Coolant Filter (cont).

(2) Removal (cont).

STEP	LOCATION	ITEM	ACTION	REMARKS
INSTALLATION (cont)				
6	Engine, right side	a. Pipe plug (9) and fitting (8)	a. Tape b. Install	Wrap threads with Teflon tape
		b. Clamp (6)	Install	On hose (7)
		c. Hose (7)	Connect	To fitting (8); tighten clamp (6)
		d. Bushing (5) and connector (4)	a. Tape b. Install	Wrap threads with Teflon tape
		e. Clamp (2)	Install	On hose (3)
		f. Hose (3)	Connect	To connector (4); tighten clamp (2)
		g. New tie strap (1)	Install	At location noted during removal
7	Filter head (16)	New coolant filter element	Install	Para 2-15b(1)
8	Tractor	Rear platform	Install	Para 2-65c
9	Cab tilt pump	Cab		Lower To normal operating position

2-15. COOLING SYSTEM MAINTENANCE (CONT)

c. Hoses.

This task covers: a. Removal c. Inspection
 b. Cleaning d. Installation

INITIAL SETUP:

Tools

No. 1 Common Organizational Maintenance
 Tool Kit
 Combination wrench set
 Socket wrench set
 Safety glasses

Personnel Required

Wheel Vehicle Mechanic NOS 63B

Equipment Condition

Paragraph Condition Description

Materials/Parts

Cleaning

 solvent Item 1, Appendix C
 Clean cloths Item 2, Appendix C
 Antifreeze Item 25, Appendix C
 Detergent Item 27, Appendix C
 Teflon tape Item 43, Appendix C
 Four tie straps FSCM 96906 PN MS3667-1-9

2-15b(1) Parked on level surface;
 parking brake applied; engine
 off.
 Cab tilted 45 degrees.
 Cooling system drained.

STEP	LOCATION	ITEM	ACTION	REMARKS
------	----------	------	--------	---------

REMOVAL

1	Engine, front, water pump	a. Two clamps (1)	Loosen	
		b. Hose (2)	Remove	
		c. Two clamps (1)	Remove	
		d. Clamp (3)	Loosen	
		e. Elbow (4)	Remove	
		f. Clamp (3)	Remove	
		g. Clamp (5)	Loosen	
		h. Hose (6)	Remove	
		i. Clamp (5)	Remove	
		j. Clamp (7)	Loosen	
		k. Elbow (8)	Remove	
		l. Clamp (7)	Remove	
		m. Clamp (9)	Loosen	
		n. Hose (10)	Remove	
		o. Clamp (9)	Remove	
2	Oil cooler	a. Clamp (11)	Loosen	
		b. Hose (16)	Disconnect	From elbow (12)
		c. Clamp (11)	Remove	
		d. Elbow (12)	Remove	

2-15. COOLING SYSTEM MAINTENANCE (CONT)

c. Hoses (cont).

KEY

- | | |
|--------------------|---------------|
| 1. Clamps (2) | 20. Clamp |
| 2. Hose | 21. Clamp |
| 3. Clamp | 22. Tie strap |
| 4. Elbow | 23. Hose |
| 5. Clamp | 24. Clamp |
| 6. Hose | 25. Hose |
| 7. Clamp | 26. Connector |
| 8. Elbow | 27. Elbow |
| 9. Clamp | 28. Connector |
| 10. Hose | |
| 11. Clamp | |
| 12. Elbow | |
| 13. Clamp | |
| 14. Clamp | |
| 15. Tie straps (3) | |
| 16. Hose | |
| 17. Clamp | |
| 18. Clamp | |
| 19. Hose | |

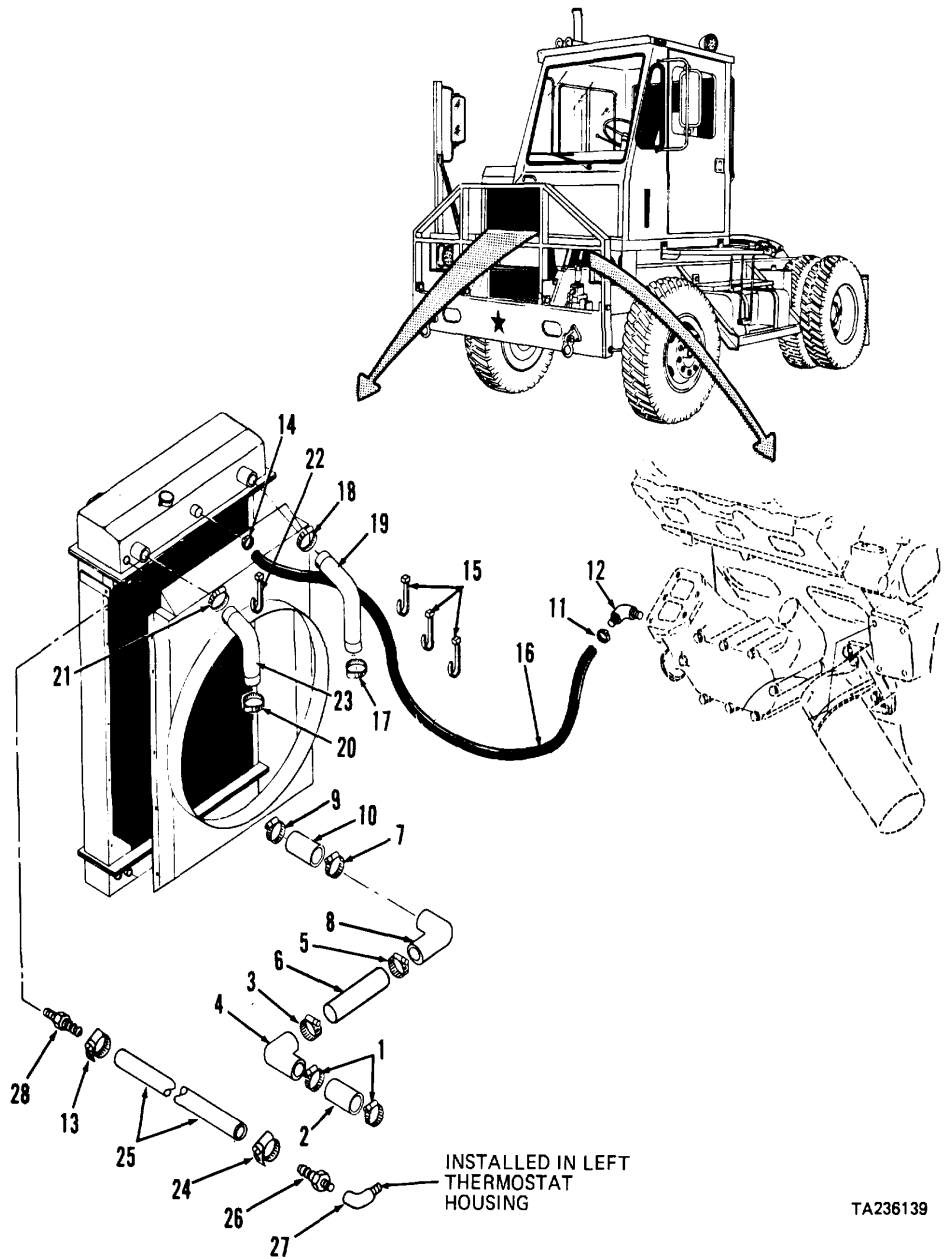

TA236139

2-15. COOLING SYSTEM MAINTENANCE (CONT)

c. Hoses (cont).

STEP	LOCATION	ITEM	ACTION	REMARKS
REMOVAL (cont)				
3	Radiator, top	a. Clamp (14) b. Three tie straps (15) c. Hose (16) d. Clamp (14) e. Clamp (13) f. Hose (25) g. Clamp (13) h. Connector (28)	Loosen Cut, remove, and discard Remove Remove Loosen Disconnect Remove Remove	Note locations for installation
4	Thermostat housing (right side) and radiator, top	a. Clamps (17 and 18) b. Hose (19) c. Clamps (17 and 18)	Loosen Disconnect and remove Remove	
5	Thermostat housing (left side) and radiator, top	a. Clamps (20 and 21) b. Tie strap (22) c. Hose (23) d. Clamps (20 and 21) e. Clamp (24) f. Hose (25) g. Clamp (24) h. Connector (26) i. Elbow (27)	Loosen Cut, remove, and discard Disconnect and remove Remove Loosen Disconnect and remove Remove Remove Remove	Note location for installation
CLEANING				
6		a. All hoses	Clean	Use clean cloth moistened with mild detergent solution

2-15. COOLING SYSTEM MAINTENANCE (CONT)

c. Hoses (cont).

STEP	LOCATION	ITEM	ACTION	REMARKS
------	----------	------	--------	---------

CLEANING (cont)
6
(cont)

WARNING

Dry cleaning solvent (P-D-680), used to clean parts is toxic and flammable. Wear protective goggles and gloves and use only in a well ventilated area. Avoid contact with skin, eyes, and clothes and don't breathe vapors. Do not use near open flame or excessive heat and don't smoke when using it. Failure to do so could cause serious injury. If you become dizzy while using cleaning solvent, get fresh air and medical attention immediately. If contact with skin or clothes is made, flush with large amounts of water. If contact with eyes is made, wash eyes with water and seek medical aid immediately.

Compressed air must not exceed 30 psi. Wear safety glasses when drying parts with compressed air. Failure to do so could cause serious injury to eyes and possible blindness. If you hurt your eyes or if a foreign object is blown into your eyes, seek medical attention immediately.

b. All other parts	Clean	Use cleaning solvent P-D-680; dry with compressed air
--------------------	-------	---

INSPECTION

7	a. Hoses, elbows, and connectors	Inspect	Replace if cracked, split, or holes are apparent. Check inside diameter for blockage; clear blockage or replace parts
	b. All other parts	Inspect	Replace if damaged or cracked or if threads are damaged

INSTALLATION

8	Radiator, bottom and 9) oil cooler	a. Clamps (7 and	Position	On hose (10)
		b. Hose (10)	Connect	To radiator
		c. Clamp (9)	Tighten	
		e. Elbow (8)	Install	

2-15. COOLING SYSTEM MAINTENANCE (CONT)

c. Hoses (cont).

STEP	LOCATION	ITEM	ACTION	REMARKS
INSTALLATION (cont)				
8 (cont)		e. Clamp (7)	Tighten	
		f. Clamps (3 and 5)	Position	On hose (6)
		g. Hose (6)	Position	
		h. Elbow (4)	Install	
		i. Two clamps (1)	Position	On hose (2)
		j. Hose (2)	Install	
		k. Clamps (1, 3, 5, and 7)	Tighten in sequence as listed	
9	Oil cooler	a. Elbow (12)	a. Tape	Wrap threads with Teflon tape
		b. Clamp (11)	b. Install	
		c. Hose (16)	Position	On hose (16)
			Connect to elbow (12) and route to radiator	
		d. Clamp (11)	Tighten	
10	Thermostat housing (right side) and radiator	a. Clamps (17 and 18)	Position	On hose (19)
		b. Hose (19)	Install	
		c. Clamps (17 and 18)	Tighten	
11	Thermostat housing (left side) and radiator	a. Clamp (14)	Position	On hose (16)
		b. Hose (16)	Install	On radiator
		c. Clamp (14)	Tighten	
		d. Clamps (20 and 21)	Position	On hose (23)
		e. Hose (23)	Install	
		f. Clamps (20 and 21)	Tighten	
		g. New tie straps (15 and 22)	Install	In locations noted during removal

NOTE

In steps 11h thru 11j below, wrap male threads of fittings (26 thru 28) with Teflon tape before installation.

2-15. COOLING SYSTEM MAINTENANCE (CONT)

c. Hoses (cont).

STEP	LOCATION	ITEM	ACTION	REMARKS
INSTALLATION (cont)				
11 (cont)		h. Connector (28)	Install	In radiator
		i. Elbow (27)	Install	In thermostat housing
		j. Connector (26)	Install	In elbow (27)
		k. Clamps (13 and 24)	Position	On hose (25)
		l. Hose (25)	Install	
		m. Clamps (13 and 24)	Tighten	
12	Radiator, top	Radiator	Fill	Para 2-15a(1)
13	Cab tilt pump	Cab	Lower	To normal operating position

2-15. COOLING SYSTEM MAINTENANCE (CONT)

d. Fan and Drive Belts.

This task covers: a. Removal c. Inspection
 b. Cleaning d. Installation

INITIAL SETUP:

Tools

No. 1 Common Organizational Maintenance
 Tool Kit
 Safety glasses
 Combination wrench set
 Socket wrench set

Equipment Condition

Paragraph	Condition Description
	Parked on level surface; parking brake applied; engine off. Cab tilted 45 degrees.
2-13a	Engine air precleaner removed.
2-15a(1)	Cooling system drained.
2-15c	Right-hand radiator hose removed from engine thermostat housing.
2-41h(1)	Air pressure relieved.
3-5a	Right-hand radiator brace removed.

Materials/Parts

Cleaning solvent Item 1, Appendix C
 Clean cloths Item 2, Appendix C

Personnel Required

Wheel Vehicle Mechanic MOS 63B

STEP	LOCATION	ITEM	ACTION	REMARKS
------	----------	------	--------	---------

REMOVAL

NOTE

Perform steps e and f below to remove belt set (11) only.

1	Engine, front	a. Six lock nuts (1), washers (2), and fan (3)	Remove	Carefully set fan (3) inside fan shroud
		b. Fitting (4)	Loosen	
		c. Tubing (5)	Remove	From fitting (4)
		d. Four capscrews (6)	Loosen	
		e. Adjusting screw (9)	Loosen	
		f. Belt set (11)	Remove	
		g. Four capscrews (6), lock(12) washers (7), and washers (8)	Remove	Support fan clutch assembly
		h. Fan clutch assembly (12)	Remove	

2-15. COOLING SYSTEM MAINTENANCE (CONT)

d. Fan and Drive Belts (cont).

KEY

- 1. Lock nuts (6)
- 2. Washers (6)
- 3. Fan
- 4. Fitting
- 5. Tubing
- 6. Capscrews (4)
- 7. Lock washers (4)
- 8. Washers (4)
- 9. Adjusting screw
- 10. Washer
- 11. Belt set
- 12. Fan clutch assembly
- 13. Capscrews (2)
- 14. Lock washers (2)
- 15. Bracket
- 16. Capscrews (2)
- 17. Lock washers (2)
- 18. Capscrews (2)
- 19. Lock washers (2)
- 20. Fan drive support

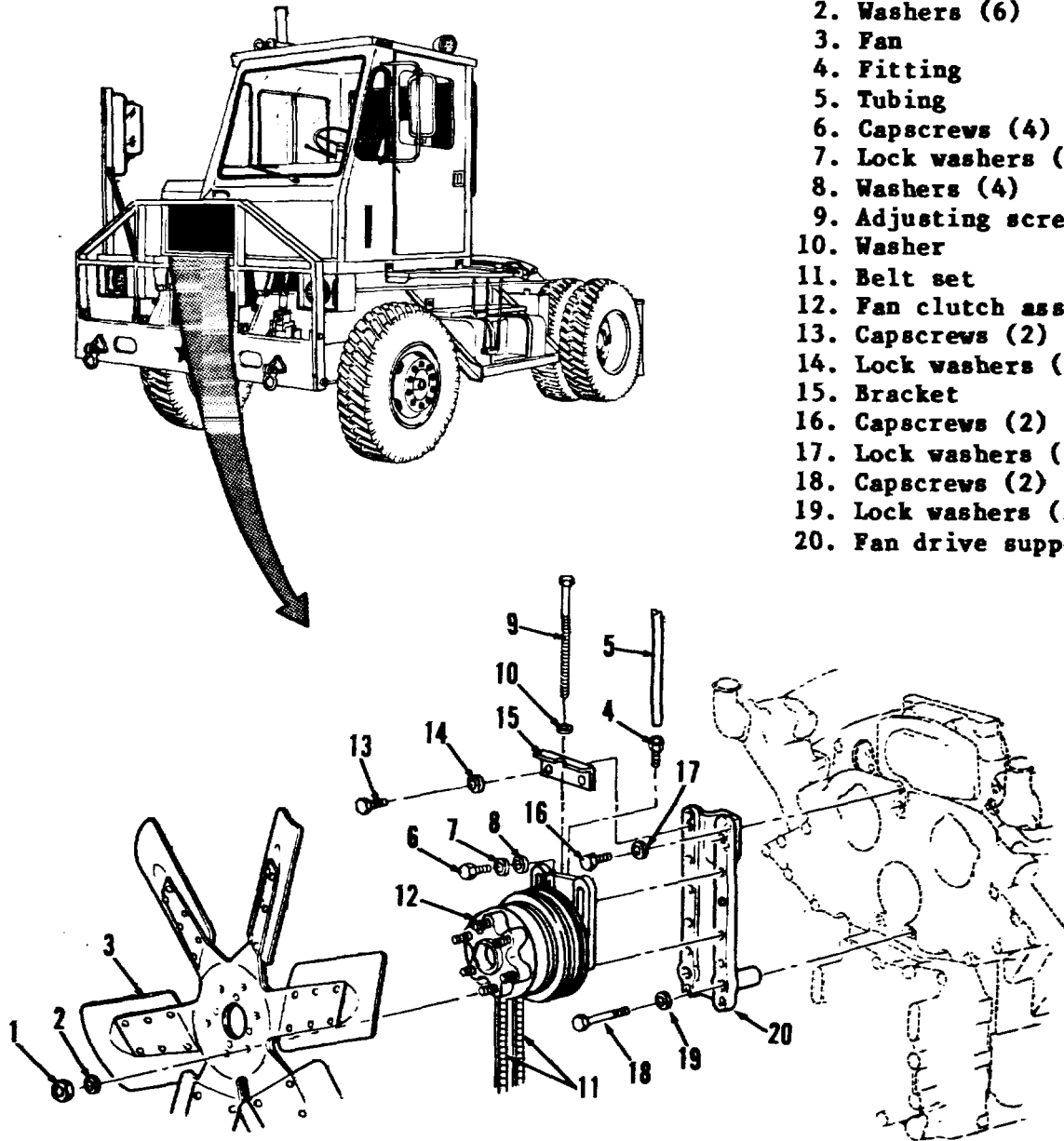

TA236140

2-15 COOLING SYSTEM MAINTENANCE (CONT)

d. Fan and Drive Belts (cont).

STEP	LOCATION	ITEM	ACTION	REMARKS
REMOVAL (cont) 1 (cont)		i. Fan (3)	Remove	Carefully pull from radiator shroud
		j. Adjusting screw (9) and washer (10)	Remove	
		k. Two capscrews (13), lock washers (14) and bracket (15)	Remove	
		l. Capscrews (16 and 18), lock washers (17 and 19), and fan drive support (20)	Remove	
CLEANING 2		a. Tubing (5), belt set (11) and fan clutch assembly (12)	Clean	Wipe with clean, damp cloth

WARNING

Dry cleaning solvent (P-D-680), used to clean parts is toxic and flammable. Wear protective goggles and gloves and use only in a well ventilated area. Avoid contact with skin, eyes, and clothes and don't breathe vapors. Do not use near open flame or excessive heat and don't smoke when using it. Failure to do so could cause serious injury. If you become dizzy while using cleaning solvent, get fresh air and medical attention immediately. If contact with skin or clothes is made, flush with large amounts of water. If contact with eyes is made, wash eyes with water and seek medical aid immediately.

Compressed air must not exceed 30 psi. Wear safety glasses when drying parts with compressed air. Failure to do so could cause serious injury to eyes and possible blindness. If you hurt your eyes or if a foreign object is blown into your eyes, seek medical attention immediately.

2-15. COOLING SYSTEM MAINTENANCE (CONT)

d. Fan and Drive Belts (cont).

STEP	LOCATION	ITEM	ACTION	REMARKS
CLEANING (cont) 2 (cont)		b. All other parts	Clean	Use cleaning solvent P-D-680; dry with compressed air
INSPECTION				
3		a. Belt set (11)	Inspect	Replace as a matched set if either belt is cracked, split, frayed, or worn
		b. Tubing (5)	Inspect	Replace if cracked, split, or holes are visible
		c. Fan (3)	Inspect	Replace if mounting holes are elongated, or if any blade is loose, cracked, bent, or otherwise damaged
		d. All other parts	Inspect	Replace if cracked, damaged, or threads damaged
INSTALLATION				

NOTE

Perform steps h and i below to install belt set (11) only.

4	Engine, front	a. Fan drive support (20)	Position	At front of engine
		b. Capscrews (16 and 18) and lock washers (17 and 19)	Install and tighten	Tighten to 48 pounds foot
		c. Bracket (15) (20)	Position	At top of fan drive support
		d. Two capscrews (13) and lock washers (14)	Install and tighten	Tighten to 33 pounds foot
		e. Fan (3)	Position	Carefully place inside radiator shroud
		f. Fan clutch assembly (12)	Position	On fan drive support (20), with mounting holes aligned
		g. Four capscrews (6), lock washers (7), and washers (8)	Install	Do not tighten at this time loosely

2-15. COOLING SYSTEM MAINTENANCE (CONT)

d. Fan and Drive Belts (cont).

STEP	LOCATION	ITEM	ACTION	REMARKS
INSTALLATION (cont)				
4 (cont)		h. Belt set (11)	Position	In grooves of fan drive and engine crankshaft pulleys
		i. Adjusting screw (9) and washer (10)	Install and tighten	Tighten until thumb pressure at midpoint between pulleys deflects belt set 1/2 inch
		j. Four capscrews (6)	Tighten	Tighten to 48 pounds foot
		k. Tubing (5)	Install	In fitting (4)
		l. Fitting (4)	Tighten	To secure tubing (5)
		m. Fan (3)	Position	Carefully pull from radiator shroud and place on studs of fan clutch assembly (12)
		n. Six washers (2) and lock nuts (1)	Install and tighten	
5	Radiator, right side	Radiator brace	Install	Para 3-5a
6	Engine, right side	Radiator hose	Install	Para 2-15c
7	Engine air cleaner	Precleaner	Install	Para 2-13a
8	Radiator, top	Radiator filler neck	Fill	Para 2-15a(1)
9	Air tank	Drain cock	Close	Para 2-41h(1)

NOTE

Start engine and check for proper operation of air system, cooling system, and fan clutch assembly before releasing vehicle to operating personnel.

2-15. COOLING SYSTEM MAINTENANCE (CONT)

e. Fan Clutch Control System. This task covers:

- a. Servicing
- b. Removal
- c. Cleaning
- d. Inspection
- e. Testing
- f. Installation

INITIAL SETUP:

Tools

No. 1 Common Organizational Maintenance Tool Kit

- Socket wrench set
- Combination wrench set
- Safety glasses
- Multimeter
- Tool kit, electrical connector
- Crimping tool
- Wire stripper

Personnel Required

Wheel Vehicle Mechanic MOS 63B

Equipment Condition

Paragraph	Condition Description
2-41h(1)	Parked on level surface; parking brake applied; engine off. Cab tilted 45 degrees. All air pressure relieved (for removal).

Materials/Parts

Cleaning

- solvent Item 1, Appendix C
- Clean cloths Item 2, Appendix C
- Detergent Item 27, Appendix C
- Teflon tape Item 43, Appendix C
- O-ring FSCM 31875 PN P390
- Tie straps FSCM 96906 PN MS3667-1-9

KEY

- | | |
|-------------------------|-----------------------------|
| 1. Filter drain | 16. Screws (4) |
| 2. Wire assembly | 17. Tie straps (7) |
| 3. Nut | 18. Harness plug |
| 4. Ignition switch lead | 19. Connector terminals (2) |
| 5. Nut | 20. Filter |
| 6. Thermal switch lead | 21. Reducer bushing |
| 7. Thermal switch | 22. Elbow |
| 8. Fitting | 23. Washer |
| 9. Tubing | 24. Plate |
| 10. Fitting | 25. O-ring |
| 11. Tubing | 26. Wire loom |
| 12. Fitting | 27. Crimp connector |
| 13. Elbow | 28. Wire loom |
| 14. Nuts (4) | 29. Solenoid |
| 15. Lock washers (4) | |

2-15. COOLING SYSTEM MAINTENANCE (CONT)

e. Fan Clutch Control System (cont).

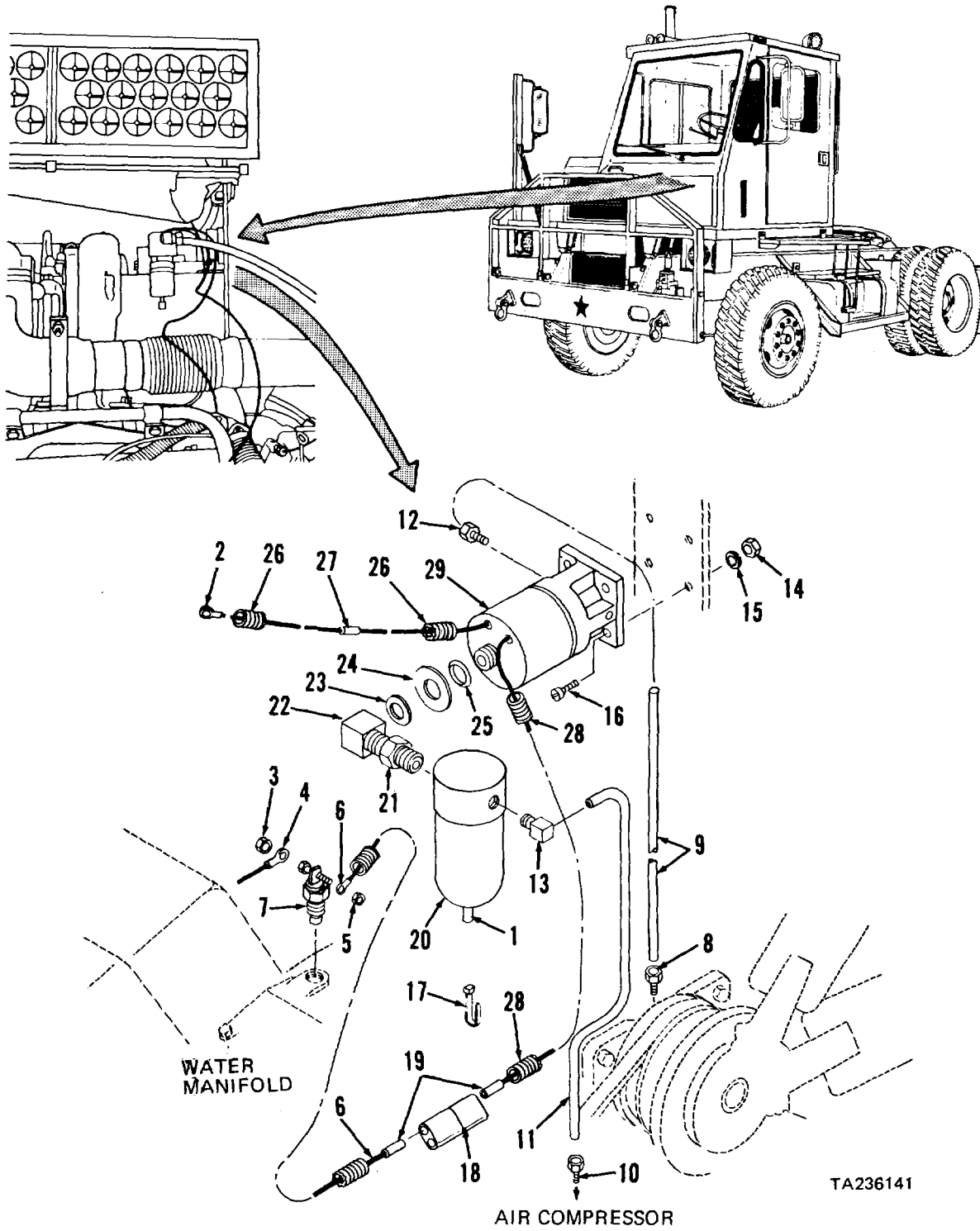

2-15. COOLING SYSTEM MAINTENANCE (CONT)

e. Fan Clutch Control System (cont).

STEP	LOCATION	ITEM	ACTION	REMARKS
------	----------	------	--------	---------

SERVICING

NOTE

Filter must be drained of water weekly.

1 from filter	Air cleaner support, left front	Filter drain (1)	Loosen and drain water	Drain water
------------------	---------------------------------	------------------	------------------------	-------------

REMOVAL

2	Alternator, rear	Wire assembly (2)	Tag and disconnect	Connected to alternator by screw located at eight o'clock position at rear of alternator
3	Radiator and engine	Coolant	Drain	Only if thermal switch (7) is to be removed; para 2-15a(l)
4	Water manifold, right hand side	a. Ignition switch lead (4) b. Nut (3) c. Ignition switch lead (4) d. Thermal switch lead (6) e. Nut (5) f. Thermal switch lead (6) g. Thermal switch (7)	Tag Remove Disconnect Tag Remove Disconnect Remove	From thermal switch (7) From thermal switch (7) From water manifold port
5	Fan clutch	a. Fitting (8) b. Tubing (9) c. Fitting (8)	Loosen nut Disconnect Remove	From fitting (8) From fan clutch
6	Air compressor	a. Fitting (10) b. Tubing (11) c. Fitting (10)	Loosen nut Disconnect Remove	From fitting (10) From air compressor

2-15. COOLING SYSTEM MAINTENANCE (CONT)

e. Fan Clutch Control System (cont).

STEP	LOCATION	ITEM	ACTION	REMARKS
REMOVAL (cont)				
NOTE				
In the following steps, cut and remove seven tie straps (17) as necessary to remove wires and solenoid (29). Note locations for installation.				
7	Air cleaner support, left front	a. Fitting (12) b. Tubing (9) c. Fitting (12) d. Elbow (13) e. Tubing (11) f. Harness plug (18) g. Four nuts (14), lock washers (15), and screws (16) h. Solenoid (29) and filter (20)	Loosen nut Disconnect from fitting (12) and remove Remove Loosen nut Disconnect from elbow (13) and remove Disconnect Remove Remove	From wiring harness receptacle Support solenoid (29) and filter (20)
8	Solenoid (29) and filter (20)	a. Filter (20) b. Reducer bushing (21) c. Elbow (22) d. Washer (23), plate (24), and O-ring (25)	Remove Remove Remove Remove	Unscrew from fitting (21) Replace solenoid (29) assembly if elbow (22) cannot be removed Discard O-ring
NOTE				
Perform step 9 below only if solenoid (29) is to be replaced or if inspection indicates that wire leads or harness plug require replacement.				
9	Solenoid (29)	a. Wire loom (26) b. Crimp connector (27) c. Thermal switch lead (6) d. Wire loom (28)	Remove Remove Disconnect Remove	Cut wires as close to ends of crimp connector as possible From harness plug (18)

2-15. COOLING SYSTEM MAINTENANCE (CONT)

e. Fan Clutch Control System (cont).

STEP	LOCATION	ITEM	ACTION	REMARKS
CLEAINING				
10		a. Tubing (9 and 11)	Clean	Use clean cloth moistened with detergent solution

WARNING

Dry cleaning solvent (P-D-680), used to clean parts is toxic and flammable. Wear protective goggles and gloves and use only in a well ventilated area. Avoid contact with skin, eyes, and clothes and don't breathe vapors. Do not use near open flame or excessive heat and don't smoke when using it. Failure to do so could cause serious injury. If you become dizzy while using cleaning solvent, get fresh air and medical attention immediately. If contact with skin or clothes is made, flush with large amounts of water. If contact with eyes is made, wash eyes with water and seek medical aid immediately.

		b. Solenoid (29) and filter (20)	Clean	Use clean cloth moistened with cleaning solvent P-D-680; dry with clean cloths
		c. Remaining parts	Clean	Use cleaning solvent P-D-680; dry using clean cloths

INSPECTION

11		a. Tubing (9 and 11)	Inspect for cracks splits blockage	Replace if defects observed
		b. Filter (20)	Inspect for cracks dents damage	Replace if defects observed
		c. Thermal switch (7)	Inspect for cracks terminals: loose corroded broken	Replace if defects observed

2-15. COOLING SYSTEM MAINTENANCE (CONT)

e. Fan Clutch Control System (cont).

STEP	LOCATION	ITEM	ACTION	REMARKS
INSPECTION (cont)				
11 (cont)		d. Solenoid (29)	Inspect for cracks lead insu- lation cracked threads damaged	Replace if defects observed
		e. Remaining parts	Inspect for cracks threads damaged distortion	Replace if defects observed
TESTING				
12		a. Solenoid (29)	a. Connect to a source of clean air; with air pressure applied, air should vent from outlet port b. With air source connected to solenoid, connect wire leads to 12 volt battery. Air should not vent from outlet port c. If above indications are not obtained, replace solenoid (29)	
		b. Thermal switch (7)	a. Connect ohmmeter across terminals and check that ohmmeter indicates zero ohms; replace thermal switch if proper indication is not obtained b. Wrap threads of thermal switch with Teflon tape and install in water mani- fold. Fill radiator and engine with coolant; para 2-15a(l) c. Connect ohmmeter across thermal switch terminals and start engine. When engine temperature reaches approximately 190 degrees, ohmmeter should indicate open circuit (infinity). Replace thermal switch if proper indication is not obtained. Turn engine off after completion of test	

2-15. COOLING SYSTEM MAINTENANCE (CONT)

e. Fan Clutch Control System (cont).

INSTALLATION

NOTE

Perform steps 13a, 13b, and 13d thru 13f only if solenoid (29) or wire assembly (2) have been replaced.

13	Solenoid (29)	a. Wire loom (28)	Install	If removed; install on wire lead shown
		b. Connector terminal (19)	Install, crimp, and connect	On wire lead loom (28) was installed on. Connect to harness plug as shown below

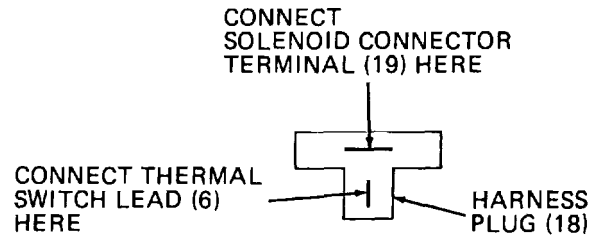

TA236393

		c. Thermal switch lead (6)	Connect	To harness plug (18) as shown above
		d. Wire assembly (2)	Strip	1/4 inch insulation from end of wire
		e. Solenoid (29) red lead	Strip	1/4 inch insulation from end of wire
		f. Crimp connector (27)	Install and crimp	Insert ends of wires stripped in steps d and e above into crimp connector; then crimp
		g. Wire loom (26)	Install	Over wire assembly (2) and solenoid (29) red lead
14	Air cleaner support, left front	a. Solenoid (29) and filter assembly (20)	Position	
		b. Four screws (16), lock washers (15), and nuts (14)	Install and tighten	
		c. Tubing (11)	Connect	To elbow (13)
		d. Elbow (13) nut	Tighten	Secures tubing (11)

2-15. COOLING SYSTEM MAINTENANCE (CONT)

e. Fan Clutch Control System (cont).

STEP	LOCATION	ITEM	ACTION	REMARKS
INSTALLATION (cont)				
14 (cont)		e. Fitting (12) f. Tubing (9) g. Fitting (12) nut	Install Connect Tighten	In solenoid (29) port To fitting (12) Secures tubing (9)
		h. New O-ring (25), plate (24), washer (23), and elbow (22)	Install	
		i. Reducer bushing (21)	Install	
		j. Filter (20)	Install	Position as shown; filter must be vertical
		k. Elbow (13)	Install	In filter (20) port
15	Air com- pressor	a. Fitting (10) b. Tubing (11)	Install Route and connect	To fitting (10)
		c. Fitting (10) nut	Tighten	Secures tubing (11)
16	Fan clutch	a. Fitting (8) b. Tubing (9)	Install Route and connect	To fitting (8)
		c. Fitting (8)	Tighten	Secures tubing (9)
NOTE				
Thermal switch (7) was installed at time of thermal switch testing (step 12b above).				
17	Water mani- fold, right hand side	a. Thermal switch lead (6) b. Nut (5)	Connect Install and tighten	
		c. Ignition switch lead (4)	Connect	
		d. Nut (3)	Install and tighten	
18	Alternator	Wire assembly (2)	Connect	To alternator using screw installed at eight o'clock position

2-15. COOLING SYSTEM MAINTENANCE (CONT)

e. Fan Clutch Control System (cont).

STEP	LOCATION	ITEM	ACTION	REMARKS
INSTALLATION (cont)				
19	Engine left side, top	a. Harness plug (18) b. Seven new tie straps (17)	Connect Install	To wiring harness connector At locations noted during removal; secures tubing (9 and 10) to existing tubes and wires
20 position	Cab tilt pump	Cab		Lower To normal operating
21	Air reservoir	Drain cock	Close	Para 2-41h(1)

2-15. COOLING SYSTEM MAINTENANCE (CONT)

f. Coolant Recovery System.

This task covers: a. Removal c. Inspection
 b. Cleaning d. Installation

INITIAL SETUP:

Tools

No. 1 Common Organizational Maintenance
 Tool Kit
 Socket wrench set

Materials/Parts

Cleaning solvent Item 1, Appendix C
 Clean cloths Item 2, Appendix C
 Detergent Item 27, Appendix C

Personnel Required

Wheel Vehicle Mechanic MOS 63B

Equipment Condition

Paragraph Condition Description

Vehicle parked on level
 surface, engine off, parking
 brake applied, and hood open.

KEY

- 1. Clamp
- 2. Hose
- 3. Capscrew
- 4. Nut
- 5. Recovery tank
- 6. Nuts (2)
- 7. Lock washers (2)
- 8. Bracket

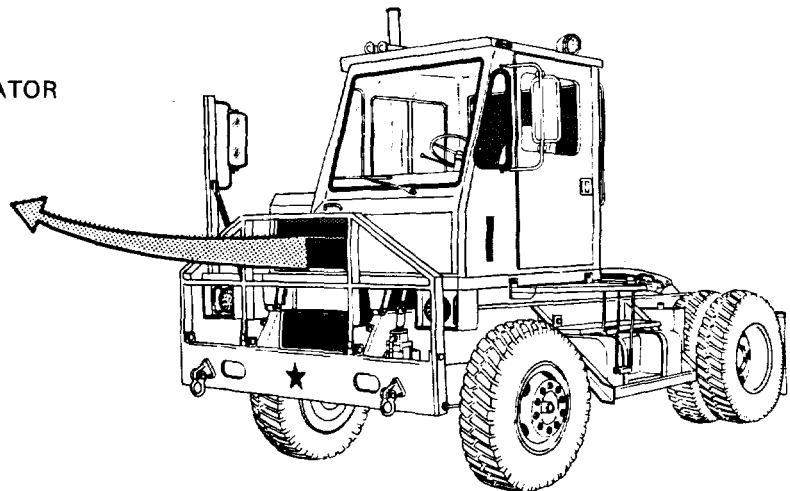
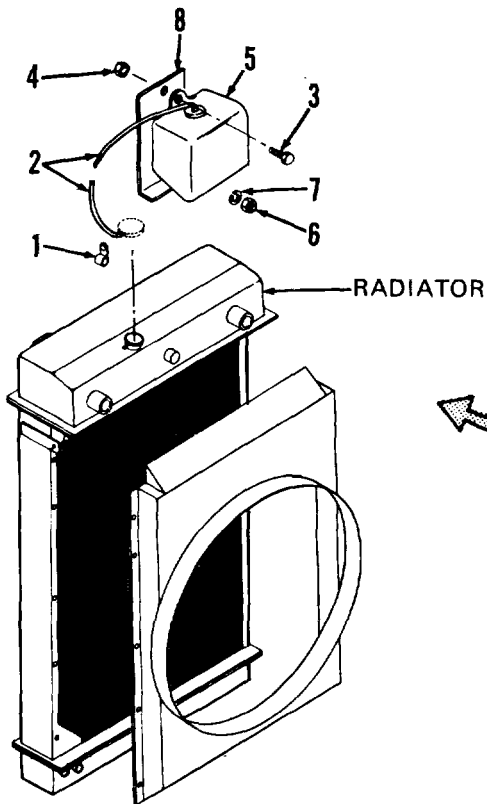

TA236396

2-15. COOLING SYSTEM MAINTENANCE (CONT)

f. Coolant Recovery System (cont).

STEP	LOCATION	ITEM	ACTION	REMARKS
REMOVAL				
1	Radiator	a. Clamp (1)	Slide over hose (2)	
		b. Hose (2)	Disconnect and remove	From radiator and recovery tank
		c. Capscrew (3) and nut (4)	Remove	Support recovery tank
		d. Recovery tank (5)	Remove	
		e. Two nuts (6) and lock washers (7)	Remove	Support bracket (8)
		f. Bracket (8)	Remove	
CLEANING				
2		a. Hose (2) and recovery tank (5)	Clean	Use detergent and clean cloth; dry using clean cloth. Clean interior of tank by allowing detergent to stand in tank overnight then rinse with clear water

WARNING

Dry cleaning solvent (P-D-680), used to clean parts is toxic and flammable. Wear protective goggles and gloves and use only in a well ventilated area. Avoid contact with skin, eyes, and clothes and don't breathe vapors. Do not use near open flame or excessive heat and don't smoke when using it. Failure to do so could cause serious injury. If you become dizzy while using cleaning solvent, get fresh air and medical attention immediately. If contact with skin or clothes is made, flush with large amounts of water. If contact with eyes is made, wash eyes with water and seek medical aid immediately.

b. Remaining parts	Clean	Use cleaning solvent P-D-680; dry using clean cloths
--------------------	-------	--

2-15. COOLING SYSTEM MAINTENANCE (CONT)

f. Coolant Recovery System (cont).

STEP	LOCATION	ITEM	ACTION	REMARKS
INSPECTION				
3		a. Hose (2)	Inspect for cracks breaks deteriora- tion	Replace if defects observed
		b. Recovery tank (5)	Inspect for cracks leakage	Replace if defects observed
		c. Bracket (8) and clamp (1)	Inspect for cracks breaks dents corrosion	Replace if defects observed
		d. Remaining parts	Inspect for cracks breaks damaged threads	Replace if defects observed
INSTALLATION				
4	Radiator	a. Bracket (8) b. Two lock washers (7) and nuts (6)	Position Install and tighten	On radiator
		c. Recovery tank (5)	Position	On bracket (8)
		d. Capscrew (3) and nut (4)	Install	
		e. Clamp (1)	Position	On hose (2)
		f. Hose (2)	Connect	To radiator and recovery tank
		g. Clamp (1)	Position	Secures hose (2) to tank (5)
5	Radiator, side	Recovery tank (5)	Fill	To line with coolant; para 2-15a(1)
6	Vehicle, side	Hood	Close	

Section V. ELECTRICAL SYSTEM MAINTENANCE

This section contains the information you need to maintain the:

- Alternator
- Starter
- Instrument Panel
- Light Systems
- Sending Units
- Horn
- Batteries

It gives you instructions on how to troubleshoot problems and repair or replace the components that are within the scope of organizational maintenance.

	Para		Para
Troubleshooting Symptom Index.....	2-16	WATER LEVEL, WATER TEMP, OIL PRESSURE, and LOW AIR Warning Lights and 24V INVERTER Light.....	2-26b(4)
Charging System Troubleshooting	2-17	Water Level Warning Bell and Low Air Pressure Buzzer.....	2-26c
Starting System Troubleshooting	2-18	Water Level Warning Bell	2-26c(1)
Instrument Panel Trouble- shooting.....	2-19	Low Air Pressure Buzzer.....	2-26c(2)
Light Systems Troubleshooting	2-20	Gage Lights and Dash Lights.....	2-26d
Sending Units Troubleshooting	2-21	Gage Lights.....	2-26d(1)
Horn System Troubleshooting.....	2-22	Dash Lights	2-26d(2)
Battery System Troubleshooting	2-23	Ammeter and 40A Circuit Breaker	2-26e
Alternator Maintenance	2-24	Voltmeter.....	2-26f
Starting System Maintenance.....	2-25	Instrument Panels	2-26g
Solenoid and 70 AMP Circuit Breaker.....	2-25a	Front Panel	2-26g(1)
Starter.....	2-25b	Right Corner Panel	2-26g(2)
Instrument Panel Maintenance.....	2-26	Right Panel.....	2-26g(3)
Switches	2-26a	Turn Signal Control Maintenance.....	2-27
Ignition Switch	2-16a(1)	Engine Warning Kit Maintenance.....	2-28
Quick Start Switch.....	2-26a(2)	Water Level Warning Kit Main- tenance	2-29
Engine Stop Switch	2-26a(3)	24V Inverter Maintenance	2-30
Headlight Switch and 30 Ampere Circuit Breaker ...	2-26a(4)	Light Systems Maintenance.....	2-31
Dimmer Switch	2-26a(5)	Headlights	2-31a
Flood Light Switches	2-26a(6)	Tail and Stop Lights	2-31b
Trailer Light Switch.....	2-26a(7)	Cab Interior Light.....	2-31c
Blower Switch.....	2-26a(8)	Front Turn Indicator Lights.....	2-31d
24V INVERTER Switch	2-26a(9)	Marker Lights	2-31e
Turn Signal Flasher.....	2-26a(10)	Trailer Lighting Cables	2-31f
Indicator Lights	2-26b	Flood Lights.....	2-31g
High Beam Indicator Light....	2-26b(1)		
TRANS/TORQUE CONVERTER Light.....	2-26b(2)		
LOW FUEL INDICATOR Light and Circuit Board.....	2-26b(3)		

	Para
Sending Units and Switches	
Maintenance.....	2-32
Oil Pressure Sender and Oil	
Pressure Sensor.....	2-32a
Fuel Level Sender	2-32b
Water Temperature Sender and	
Alarmstat	2-32c
Transmission Temperature	
Sender.....	2-32d
Neutral Start and Backup	
Light Switches	2-32e
Stop Light Switches.....	2-32f
Service Brakes Stop Light	
Switch.....	2-32f(1)
Trailer Hand Brake Stop	
Light Snitch.....	2-32f(2)
Horn System Maintenance	2-33
Horn and Relay.....	2-33a
Horn Snitch.....	2-33b

	Para
Battery System Maintenance	2-34
Battery Cables and Batteries	2-34a
Battery Box.....	2-34b
Wiring Harness Maintenance	2-35
Cab Harnesses	2-35a
Upper Cab Harness	2-35a(1)
Lower Cab Harness	2-35a(2)
Chassis Harnesses	2-35b
Front Chassis Harness	2-35b(1)
Rear Chassis Harness	2-35b(2)
Instrument Panel Harnesses.....	2-35c
Front Panel Harness	2-35c(1)
Right Corner Panel Harness .	2-35c(2)
Right Panel Harness	2-35c(3)
Engine Harness.....	2-35d
Ground Straps.....	2-35e
Diodes	2-35f
Circuit Breakers and Fuse	2-35g

2-16. TROUBLESHOOTING SYMPTOM INDEX**NOTE**

An electrical system wiring schematic is located at the back of this manual in appendix E.

	Para/Malfunction	Page
CHARGING SYSTEM		
Alternator overcharging	2-17/1	2-169
Alternator undercharging	2-17/2	2-169
STARTING SYSTEM		
Engine will not start	2-18/1	2-169
Starter cranks continuously	2-18/2	2-171
INSTRUMENT PANEL		
WATER LEVEL warning light and bell not operating properly.....	2-19/1	2-172
WATER TEMP warning light or bell not operating properly.....	2-19/2	2-173
OIL PRESSURE warning light or bell not operating properly.....	2-19/3	2-174
LOW AIR warning light and buzzer not operating properly	2-19/4	2-175
LOW FUEL INDICATOR lamp does not light when fuel tank is empty.....	2-19/5	2-176
LOW FUEL INDICATOR lamp lights when fuel tank is full	2-19/6	2-177
Voltmeter inoperative	2-19/7	2-177
Ammeter inoperative	2-19/8	2-177
Dash lights and gage lights inoperative	2-19/9	2-178
Engine stop switch doesn't stop engine	2-19/10	2-180
LIGHT SYSTEMS		
Trailer lights inoperative (12-volt trailer)	2-20/1	2-180
Trailer lights inoperative (24-volt trailer)	2-20/2	2-182
Turn signal lights inoperative	2-20/3	2-184
Headlights inoperative	2-20/4	2-185
Marker lights and tail lights inoperative	2-20/5	2-186
SENDING UNITS		
WATER TEMP warning light and bell not operating properly.....	2-21/1	2-188
OIL PRESSURE warning light and bell not operating properly.....	2-21/2	2-188
LOW FUEL INDICATOR light and FUEL gage not operating properly.....	2-21/3	2-189
Vehicle stop lights won't operate.....	2-21/4	2-189
Trailer stop lights won't operate.....	2-21/5	2-189
HORN SYSTEM		
Electric horn does not sound.....	2-22/1	2-190
BATTERY SYSTEM		
Batteries require frequent filling.....	2-23/1	2-191
Batteries fail to maintain charge	2-23/2	2-192

2-17. CHARGING SYSTEM TROUBLESHOOTING

MALFUNCTION
TEST OR INSPECTION
CORRECTIVE ACTION

1. ALTERNATOR OVERCHARGING

- Step 1. Shut down engine, open engine hood, and check alternator terminals for loose electrical connections.
- a. If electrical leads at alternator terminals are loose, tighten.
 - b. If electrical leads at alternator terminals are not loose, go to step 2 below.
- Step 2. Perform alternator on-vehicle tests for overcharging (para 2-24).
- a. If tests indicate parts are defective, replace (para 2-24).
 - b. If tests do not indicate parts are defective, notify direct support maintenance.

2. ALTERNATOR UNDERCHARGING

- Step 1. Check alternator belt tension (para 2-24).
- a. If alternator belts are loose, tighten (para 2-24).
 - b. If alternator belts are not loose, go to step 2 below.
- Step 2. Perform alternator on-vehicle tests for undercharging (para 2-24).
- a. If tests indicate parts are defective, replace (para 2-24).
 - b. If tests do not indicate parts are defective, notify direct support maintenance.

2-18. STARTING SYSTEM TROUBLESHOOTING

MALFUNCTION
TEST OR INSPECTION
CORRECTIVE ACTION

1. ENGINE WILL NOT START

- Step 1. Check that gear shift lever is in neutral (N) position.
- a. If gear shift lever is in a drive position, place it in neutral (N) position.
 - b. If gear shift lever is in neutral (N), go to step 2 below.

2-18. STARTING SYSTEM TROUBLESHOOTING (CONT)

MALFUNCTION
TEST OR INSPECTION
CORRECTIVE ACTION

1. ENGINE WILL NOT START (Cont)

- Step 2. Hold key switch in start position.
Move gear shift lever slightly to each side of neutral (N) position.
- a. If engine starts, adjust neutral start switch (para 2-32e).
 - b. If engine does not start, go to step 3 below.
- Step 3. Check 70 AMP circuit breaker on starter motor for tripped condition.
- a. If 70 AMP circuit breaker is tripped, go to step 4 below.
 - b. If 70 AMP circuit breaker is not tripped, go to step 5 below.
- Step 4. Firmly press red reset button on 70 AMP circuit breaker.
- a. If 70 AMP circuit breaker trips, check for short in electrical system wiring; repair or replace as necessary (para 2-35a thru 2-35d).
 - b. If 70 AMP circuit breaker does not trip and engine will not start, go to step 5 below.
- Step 5. Check for loose, corroded, or damaged battery cables and terminals.
- a. If battery cables are loose, tighten connections. If cables or terminals are damaged or corroded, replace (para 2-34a).
 - b. If battery cables and terminals are not loose, corroded, or damaged, go to step 6 below.
- Step 6. Using a hydrometer and thermometer, check specific gravity of battery electrolyte in each battery cell (para 2-34a).
- a. If corrected specific gravity reading is less than 1.225, recharge batteries (para 2-34a).
 - b. If specific gravity readings between cells of one battery differs by more than 25 points (0.025), replace battery (para 2-34a).
 - c. If corrected specific gravity reading is more than 1.225, and readings between cells of one battery differ by no more than 25 (0.025), go to step 7 below.

2-18. STARTING SYSTEM TROUBLESHOOTING (CONT)

MALFUNCTION	TEST OR INSPECTION	CORRECTIVE ACTION
--------------------	---------------------------	--------------------------

1. ENGINE WILL NOT START (Cont)

Step 7. Perform solenoid and 70 AMP circuit breaker on-vehicle tests (para 2-25a).

- a. If tests do not indicate parts are defective, go to step 8 below.
- b. If tests indicate parts are defective, repair or replace (para 2-25b).

Step 8. Perform starter on-vehicle tests (para 2-25b).

- a. If tests indicate parts are defective, replace (para 2-25b).
- b. If tests do not indicate parts are defective, notify direct support maintenance.

2. STARTER CRANKS CONTINUOUSLY

Step 1. Connect voltmeter leads to starter solenoid control terminal (tan/green electrical lead) and to ground. Turn key switch to on position.

- a. If voltmeter indicates 12-14 Vdc, go to step 2 below.
- b. If voltmeter indicates zero volts, notify direct support maintenance.

Step 2. Disconnect tan/brown electrical lead from key switch ST terminal. Turn key switch to on position. Check if starter cranks.

- a. If starter cranks, check for short in starting system wiring; repair or replace as necessary (para 2-25a).
- b. If starter does not crank, replace ignition switch (para 2-26a(1)).

2-19. INSTRUMENT PANEL TROUBLESHOOTING

MALFUNCTION	TEST OR INSPECTION	CORRECTIVE ACTION
--------------------	---------------------------	--------------------------

1. WATER LEVEL WARNING LIGHT AND BELL NOT OPERATING PROPERLY

- | | |
|---------|---|
| Step 1. | Disconnect oil pressure sensor electrical lead (para 2-32a).
With engine stopped, turn key switch to on position.
WATER LEVEL warning lamp should light and warning bell should sound. |
| | <ul style="list-style-type: none"> a. If lamp does not light, go to step 2 below. b. If bell does not sound, go to step 3 below. c. If lamp lights, bell sounds, and OIL PRESSURE or WATER TEMP warning lamps light, go to step 4 below. |
| Step 2. | Check for continuity of WATER LEVEL warning light bulb. |
| | <ul style="list-style-type: none"> a. If bulb is defective, replace (para 2-26b(4)). b. If bulb is not defective, repair socket and wiring as required (para 2-26b(4)). |
| Step 3. | Disconnect warning bell electrical leads (para 2-26c(1)).
Connect 12 Vdc power source to bell.
Bell should sound. |
| | <ul style="list-style-type: none"> a. If bell does not sound, replace (para 2-26c(1)). b. If bell sounds, go to step 4 below. |
| Step 4. | Check continuity of diodes (para 2-35f) and brown/red electrical lead connecting diodes and bell. |
| | <ul style="list-style-type: none"> a. If correct continuity is not obtained, replace diodes (para 2-35f) or repair wiring (para 2-35c(2)). b. If correct continuity is obtained, go to step 5 below. |
| Step 5. | With engine stopped, turn key switch to on position.
Disconnect oil pressure sensor electrical lead (para 2-32a).
Use a voltmeter to check for 12 Vdc at water level sensor blue/brown electrical lead. |
| | <ul style="list-style-type: none"> a. If voltmeter indicates 12 Vdc, repair or replace electrical lead (para 2-32a). b. If voltmeter indicates zero, go to step 6 below. |

2-19. INSTRUMENT PANEL TROUBLESHOOTING (CONT)
--

MALFUNCTION	TEST OR INSPECTION	CORRECTIVE ACTION
--------------------	---------------------------	--------------------------

1. WATER LEVEL WARNING LIGHT AND BELL NOT OPERATING PROPERLY (Cont)

- Step 6. Disconnect electrical leads from water level sensor (para 2-29).
With engine stopped, use an ohmmeter to check continuity of water level sensor.
Then check continuity with engine running.
- If continuity is not obtained with engine shut down, or continuity is obtained with engine running, replace water level sensor (para 2-29).
 - If continuity is obtained with engine shut down and continuity is not obtained with engine running, water level sensor is operating correctly.

2. WATER TEMP WARNING LIGHT OR BELL NOT OPERATING PROPERLY

- Step 1. Disconnect oil pressure sensor electrical lead (para 2-32a).
Disconnect water level sensor electrical leads (para 2-29).
Connect jumper lead to water temperature sensor terminal and to ground.
With engine stopped, turn key switch to on position.
WATER TEMP warning lamp should light and warning bell should sound.
- If lamp does not light, go to step 2 below.
 - If bell does not sound, go to step 3 below.
 - If lamp lights, bell sounds, and WATER LEVEL or OIL PRESSURE warning lamps light, go to step 4 below.
- Step 2. Check for continuity of WATER TEMP warning light bulb.
- If bulb is defective, replace (para 2-26b(4)).
 - If bulb is not defective, repair socket and wiring as required (para 2-26b(4)).
- Step 3. Disconnect warning bell electrical leads (para 2-26c(1)).
Connect 12 Vdc power source to bell.
Bell should sound.
- If bell does not sound, replace (para 2-26c(1)).
 - If bell sounds, go to step 4 below.

2-19. INSTRUMENT PANEL TROUBLESHOOTING (CONT)
--

MALFUNCTION
TEST OR INSPECTION
CORRECTIVE ACTION

2. WATER TEMP WARNING LIGHT OR BELL NOT OPERATING PROPERLY (Cont)

- Step 4. Check continuity of diodes (para 2-35f) and brown/red electrical lead connecting diodes and bell.
- If correct continuity is not obtained, replace diodes (para 2-35f) or repair wiring (para 2-35c(2)).
 - If correct continuity is obtained, go to step 5 below.
- Step 5. Check continuity of wiring connecting diodes and water temperature sensor.
- If continuity is not obtained, repair or replace wiring (para 2-32c).
 - If continuity is obtained, troubleshoot water temperature sensor (para 2-21).

3. OIL PRESSURE WARNING LIGHT OR BELL NOT OPERATING PROPERLY

- Step 1. Disconnect water level sensor (para 2-29).
With engine stopped, turn key switch to on position.
OIL PRESSURE warning lamp should light and bell should sound.
- If lamp does not light, go to step 2 below.
 - If bell does not sound, go to step 3 below.
 - If lamp lights, bell sounds, and WATER LEVEL or WATER TEMP warning lamps light, go to step 4 below.
- Step 2. Check for continuity of OIL PRESSURE warning light bulb.
- If bulb is defective, replace (para 2-26b(4)).
 - If bulb is not defective, repair socket and wiring as required (para 2-26b(4)).
- Step 3. Disconnect warning bell electrical leads (para 2-26c(l)).
Connect 12 Vdc power source to bell.
Bell should sound.
- If bell does not sound, replace (para 2-26c(1)).
 - If bell sounds, go to step 4 below.

2-19. INSTRUMENT PANEL TROUBLESHOOTING (CONT)
--

MALFUNCTION	TEST OR INSPECTION	CORRECTIVE ACTION
--------------------	---------------------------	--------------------------

3. OIL PRESSURE WARNING LIGHT OR BELL NOT OPERATING PROPERLY (Cont)

Step 4. Check continuity of diodes (para 2-35f) and brown/red electrical lead connecting diodes and bell.

- a. If continuity is not obtained, replace diodes (para 2-35f) or repair wiring (para 2-35c(2)).
- b. If continuity is obtained, go to step 5 below.

Step 5. Check continuity of wiring connecting diodes and oil pressure sensor.

- a. If continuity is not obtained, repair or replace wiring (para-2-32a).
- b. If continuity is obtained, replace water temperature sensor (para 2-32a).

4. LOW AIR WARNING LIGHT AND BUZZER NOT OPERATING PROPERLY

Step 1. Turn key switch to on position.
Relieve air system of all pressure (para 2-41h(1)).
LOW AIR warning lamp and low air pressure buzzer should be on.

- a. If lamp does not light and buzzer sounds, go to step 3 below.
- b. If lamp lights and buzzer does not sound, go to step 4 below.
- c. If lamp does not light and buzzer does not sound, go to step 5 below.
- d. If lamp lights and buzzer sounds, go to step 2 below.

Step 2. Start engine.
Allow air system pressure to build to 76 psi.
Watch LOW AIR warning light and listen to low air pressure buzzer.
LOW AIR warning lamp should extinguish and buzzer should stop sounding when air system pressure reaches approximately 76 psi.

- a. If lamp does not extinguish and buzzer does not stop sounding at approximately 76 psi, troubleshoot air system (para 2-47 or 2-48).
- b. If lamp does not extinguish and buzzer does not stop sounding when air system pressure is well above 76 psi, go to step 5 below.

2-19. INSTRUMENT PANEL TROUBLESHOOTING (CONT)
--

MALFUNCTION	TEST OR INSPECTION	CORRECTIVE ACTION
--------------------	---------------------------	--------------------------

4. LOW AIR WARNING LIGHT AND BUZZER NOT OPERATING PROPERLY (Cont)

- | | | |
|---------|---|--|
| Step 3. | Check for continuity of LOW AIR warning light bulb. | |
| | a. If bulb is defective, replace (para 2-26b(4)). | |
| | b. If bulb is not defective, repair socket and wiring as required (para 2-26b(4)). | |
| Step 4. | Disconnect leads from low air pressure buzzer (para 2-26c(2)).
Connect buzzer to 12 Vdc power source; buzzer should sound. | |
| | a. If buzzer sounds, repair buzzer wiring (para 2-26c(2)). | |
| | b. If buzzer does not sound, replace buzzer (para 2-26c(2)). | |
| Step 5. | Disconnect low air pressure switch electrical leads (para 2-51c).
Allow air system pressure to build to 100 psi.
Use an ohmmeter to check low air pressure switch for continuity. | |
| | a. If continuity is obtained, with air pressure at 100 psi, replace low air pressure switch (para 2-51c). | |
| | b. If continuity is not obtained, repair or replace low air pressure switch electrical leads. | |

5. LOW FUEL INDICATOR LAMP DOES NOT LIGHT WHEN FUEL TANK IS EMPTY

- | | | |
|---------|---|--|
| Step 1. | Check if FUEL gage indicates empty. | |
| | a. If FUEL gage does not indicate empty, troubleshoot fuel level sender (para 2-21, Malfunction 3). | |
| | b. If FUEL gage indicates empty, go to step 2 below. | |
| Step 2. | Check for continuity of LOW FUEL INDICATOR light bulb. | |
| | a. If bulb is defective, replace (para 2-26b(3)). | |
| | b. If bulb is not defective, go to step 3 below. | |
| Step 3. | Check for loose connections on low fuel warning circuit board. | |
| | a. If electrical connections are loose, tighten. | |
| | b. If electrical connections are not loose, replace low fuel warning circuit board (para 2-26b(3)). | |

2-19. INSTRUMENT PANEL TROUBLESHOOTING (CONT)

MALFUNCTION
TEST OR INSPECTION
CORRECTIVE ACTION

6. LOW FUEL INDICATOR LAMP LIGHTS WHEN FUEL TANK IS FULL

Step 1. Check if FUEL gage indicates full.

- a. If FUEL gage does not indicate full, troubleshoot fuel level sender (para 2-21, Malfunction 3).
- b. If FUEL gage indicates full, go to step 2 below.

Step 2. Check LOW FUEL INDICATOR light and low fuel warning circuit board electrical leads for short in wiring.

- a. If short in wiring is found, repair (para 2-26b(3)).
- b. If short in wiring is not found, replace low fuel warning circuit board (para 2-26b(3)).

7. VOLTMETER INOPERATIVE

Step 1. Check if key switch is turned to off position.

- a. If key switch is off, turn key switch to on position.
- b. If key switch is turned to on position, go to step 2 below.

Step 2. Disconnect voltmeter electrical leads (para 2-26f).
Apply 12 Vdc power source to voltmeter terminals.

- a. If voltmeter indicates 11-13 Vdc, notify direct support maintenance (wiring).
- b. If voltmeter does not indicate 11-13 Vdc, replace voltmeter (para 2-26f).

8. AMMETER INOPERATIVE

Step 1. Check if key switch is turned to off position.

- a. If key switch is off, turn key switch to on position.
- b. If key switch is turned to on position, go to step 2 below.

2-19. INSTRUMENT PANEL TROUBLESHOOTING (CONT)

MALFUNCTION
TEST OR INSPECTION
CORRECTIVE ACTION

8. AMMETER INOPERATIVE (Cont)

- Step 2. Disconnect ammeter electrical leads (para 2-26e).
Apply 15 amperes current through ammeter terminals.
- a. If ammeter doesn't indicate 13-17 amperes, replace (para 2-26e).
 - b. If ammeter indicates 13-17 amperes, go to step 3 below.
- Step 3. Check level of electrolyte in batteries.

WARNING

Battery electrolyte is toxic and corrosive. Use protective goggles and gloves when performing the following. Avoid contact with skin, eyes, clothes, and don't breathe vapors.

- a. If electrolyte level is below plates of any cell, add distilled water to bring level 3/8 inch above plates (para 2-34a).
 - b. If electrolyte level is above plates of all cells, go to step 4.
- Step 4. Check for loose battery cables and broken battery terminals.
- a. If battery cables are loose, tighten (paragraph 2-34a).
 - b. If battery terminals are broken, replace (para 2-34a).
 - c. If battery cables and terminals are okay, go to step 5 below.
- Step 5. Inspect battery tops and terminals for corrosion.
- a. If corrosion is observed, remove.
 - b. If terminals are okay, refer to para 2-17, Malfunction 2.

9. DASH LIGHTS AND GAGE LIGHTS INOPERATIVE

- Step 1. Pull out headlight switch to first detent position.
Watch gage and dash lights.
Rotate headlight switch from full counterclockwise position to full clockwise position.
- a. If all dash and gage lamps are inoperative, go to step 3 below.
 - b. If one or more dash and gage lamps light, go to step 2 below.

2-19. INSTRUMENT PANEL TROUBLESHOOTING (CONT)
--

MALFUNCTION	TEST OR INSPECTION	CORRECTIVE ACTION
--------------------	---------------------------	--------------------------

9. DASH LIGHTS AND GAGE LIGHTS INOPERATIVE (Cont)

Step 2. Check for continuity of inoperative dash and gage light bulbs.

- a. If bulbs are defective, replace (para 2-26d(1) or 2-26d(2)).
- b. If bulbs are not defective, repair sockets and wiring as necessary (para 2-26d(1) or 2-26d(2)).

Step 3. Pull out headlight switch to first detent position and rotate switch clockwise.
Use a voltmeter to check for 12 Vdc at both sides of 4A dash light fuse (para 2-35g).

- a. If voltmeter indicates 12 Vdc at both sides of 4A fuse, repair or replace wiring between 4A fuse and dash and gage lights (para 2-35c(1), 2-35c(2), or 2-35c(3)).
- b. If voltmeter indicates 12 Vdc at only one side of 4A fuse, replace fuse (para 2-35g).
- c. If voltmeter does not indicate 12 Vdc at either side of 4A fuse, go to step 4 below.

Step 4. Pull out headlight switch to first detent position and rotate clockwise.
Use a voltmeter to check for 12 Vdc at headlight switch terminal blue/red electrical lead.

- a. If voltmeter indicates 12 Vdc, repair or replace wiring between headlight switch and 4A fuse (para 2-35c(1)).
- b. If voltmeter indicates zero, go to step 5 below.

Step 5. Use voltmeter to check for 12 Vdc at both terminals of headlight switch 30 ampere circuit breaker.

- a. If voltmeter indicates 12 Vdc at both terminals, replace headlight switch (para 2-26a(4)).
- b. If voltmeter indicates 12 Vdc only at battery side of 30 ampere circuit breaker, replace 30 ampere circuit breaker (para 2-26a(4)).
- c. If voltmeter indicates zero at both terminals of 30 ampere circuit breaker, repair or replace wiring from 30 ampere circuit breaker to ammeter and batteries.

2-19. INSTRUMENT PANEL TROUBLESHOOTING (CONT)

MALFUNCTION
TEST OR INSPECTION
CORRECTIVE ACTION

10. ENGINE STOP SWITCH DOESN'T STOP ENGINE

- Step 1. Have assistant depress engine stop button.
Use voltmeter to check for 12 Vdc at both terminals of engine stop switch.
- a. If voltmeter indicates 12 Vdc at both terminals, go to step 2 below.
 - b. If voltmeter indicates 12 Vdc at only one terminal, replace engine stop switch (para 2-26a(3)).
 - c. If voltmeter indicates zero at both terminals, repair or replace wiring between ignition switch and engine stop switch (para 2-35c(1)).
- Step 2. Have assistant depress engine stop button.
Use a voltmeter to check for 12 Vdc at engine stop solenoid.
- a. If voltmeter indicates zero, repair or replace wiring between engine stop solenoid and engine stop switch (para 2-35d).
 - b. If voltmeter indicates 12 Vdc, go to step 3 below.
- Step 3. Disconnect electrical lead from engine stop solenoid.
Use an ohmmeter to check for continuity of engine stop solenoid.
- a. If continuity is obtained, notify direct support maintenance (refer to TM 9-2815-205-34 for troubleshooting of the engine and its components).
 - b. If continuity is not obtained, replace engine stop solenoid.

2-20. LIGHT SYSTEMS TROUBLESHOOTING

MALFUNCTION
TEST OR INSPECTION
CORRECTIVE ACTION

1. TRAILER LIGHTS INOPERATIVE (12-VOLT TRAILER)

- Step 1. Check if all trailer lights are inoperative.
- a. If all trailer lights are inoperative, go to step 3 below.
 - b. If one or more trailer lights are operative, go to step 2 below.

2-20. LIGHT SYSTEMS TROUBLESHOOTING (CONT)

MALFUNCTION	TEST OR INSPECTION	CORRECTIVE ACTION
--------------------	---------------------------	--------------------------

1. TRAILER LIGHTS INOPERATIVE (12-VOLT TRAILER) (Cont)

- Step 2. Check for continuity of light bulbs in inoperative circuits.
- If trailer light bulb is defective, replace.
 - If trailer light bulb is not defective, go to step 3 below.
- Step 3. Check trailer lighting cable and 12V receptacle pins for open ground circuit (white electrical lead).
- If components are damaged, repair or replace (para 2-31f or 2-30).
 - If components are not damaged, go to step 4 below.
- Step 4. Disconnect electrical leads for inoperative light circuit from 15 ampere circuit breaker (para 2-30). Use an ohmmeter to check 15 ampere circuit breaker for continuity.
- If ohmmeter indicates more than 1 ohm, replace circuit breaker (para 2-30).
 - If ohmmeter indicates less than 1 ohm, go to step 4 below.
- Step 5. Check if turn signal lights operate.
- If turn signal lights do not operate, go to Malfunction 3, step 2.
 - If turn signal lights operate, go to step 5 below.
- Step 6. Disconnect electrical leads from trailer light switch and headlight switch (para 2-26a(4) and 2-26a(7)). Use an ohmmeter to check trailer light switch and headlight switch for continuity.
- If a switch is defective, replace (para 2-26a(4) or 2-26a(7)).
 - If switches are not defective, go to step 6 below.
- Step 7. Use an ohmmeter to check wiring between switches and 15 ampere circuit breakers for open circuit. Repair defective wiring by splicing a new length of the same size (gage) wire.

2-20. LIGHT SYSTEMS TROUBLESHOOTING (CONT)

MALFUNCTION	TEST OR INSPECTION	CORRECTIVE ACTION
--------------------	---------------------------	--------------------------

2. TRAILER LIGHTS INOPERATIVE (24-VOLT TRAILER)

- Step 1. Turn key switch and 24V INVERTER switch to on position.
Watch 24V INVERTER light.
- If 24V INVERTER lamp lights, go to step 5 below.
 - If 24V INVERTER lamp does not light, go to step 2 below.
- Step 2. Use a voltmeter to measure voltage from tractor ground to terminals of 24V INVERTER switch.
- If voltmeter indicates 12-14 Vdc at one terminal, and zero at the other terminal, replace 24V INVERTER switch (para 2-26a(9)).
 - If voltmeter indicates zero at both terminals, go to step 3 below.
 - If voltmeter indicates 12-14 Vdc at both terminals go to step 5.
- Step 3. Push up all FLOOD LIGHT switches and watch flood lights.
- If one or more flood lamps light, push down FLOOD LIGHT switches; then go to step 4 below.
 - If all flood lights are inoperative, replace 25 ampere circuit breaker (para 2-35g).
- Step 4. Check for broken conductor in brown/white electrical lead between 4V INVERTER switch and 25 ampere circuit breaker in fuse block.
- If conductor is broken, repair (para 2-35c(1) or 2-35c(2)).
 - If conductor is not broken, go to step 5 below.
- Step 5. Turn key switch to on position.
Push up 24V INVERTER switch.
Use a voltmeter to measure voltage at both terminals of ammeter 40A circuit breaker.
- If voltmeter indicates zero volts at one terminal and 12-14 Vdc at second terminal, replace 40A circuit breaker (para 2-26e).
 - If voltmeter indicates zero at both terminals, repair or replace wiring between ammeter and 40A circuit breaker (para 2-26e).
 - If voltmeter indicates 12-14 Vdc at both terminals go to step 6.

2-20. LIGHT SYSTEMS TROUBLESHOOTING (CONT)

MALFUNCTION

TEST OR INSPECTION

CORRECTIVE ACTION

2. TRAILER LIGHTS INOPERATIVE (24-VOLT TRAILER) (Cont)

Step 6. Connect voltmeter leads to 24V inverter BAT.+ terminal and tractor ground.

- a. If voltmeter indicates zero volts, repair brown/orange electrical lead between 24V inverter terminal and 40A circuit breaker by splicing a new length of the same size (gage) wire.
- b. If voltmeter indicates 12-14 Vdc, go to step 7 below.

Step 7. Connect voltmeter to IGN terminal of 24V inverter and to ground.

- a. If voltmeter indicates zero volts, repair black/yellow electrical lead between 24V inverter terminal and 24V INVERTER switch by splicing in a new length of the same size (gage) wire.
- b. If voltmeter indicates 12-14 Vdc, go to step 8 below.

Step 8. Remove 20 ampere and 30 ampere fuses from 24V inverter (para 2-30).
Use an ohmmeter to check continuity of fuses.

- a. If continuity is not obtained, replace fuses (para 2-30).
- b. If continuity is obtained, go to step 9 below.

Step 9. Turn key switch to on position.
Push up 24V INVERTER switch.
Pull out headlight switch fully.
Push in hazard warning switch.
Use voltmeter to check for 12 Vdc at terminals 4, 5, and 6 of 24V inverter.

- a. If voltmeter indicates zero at terminal 4, go to Malfunction 5.
- b. If voltmeter indicates zero at terminal 5 or 6, go to Malfunction 3.
- c. If voltmeter indicates 12 Vdc at all three terminals, go to step 10 below.

2-20. LIGHT SYSTEMS TROUBLESHOOTING (CONT)

MALFUNCTION

TEST OR INSPECTION

CORRECTIVE ACTION

2. TRAILER LIGHTS INOPERATIVE (24-VOLT TRAILER) (Cont)

Step 10. Turn key switch to on position.
 Push up 24V INVERTER switch.
 Pull out headlight switch fully.
 Push in hazard warning switch.
 Use voltmeter to check for 24 Vdc at terminals 7, 8, and 9 of 24V inverter.

- a. If voltmeter indicates zero at all three terminals, replace 24V inverter (para 2-30).
- b. If voltmeter indicates 24 Vdc at all three terminals, replace 24V receptacle (para 2-30) or trailer lighting cable (para 2-31f).

3. TURN SIGNAL LIGHTS INOPERATIVE

Step 1. Check if all turn signal lights are inoperative.

- a. If all turn signal lights are inoperative, go to step 2 below.
- b. If one or more turn signal lamps light, replace defective bulbs (para 2-31b or 2-31d).

Step 2. Unplug turn signal flasher from wiring harness connector (para 2-26a(10)).
 Depress brake pedal and have assistant watch stop lights.

- a. If stop lamps light, go to step 3 below.
- b. If stop lamps do not light, replace 20 ampere circuit breaker (para 2-35g).

Step 3. Plug a known good turn signal flasher into wiring harness connector (para 2-26a(10)).
 Check operation of turn signal lights and hazard warning flashers.

- a. If one lamp does not light, repair wiring between steering column connector and affected lamp by splicing a new length of the same size (gage).
- b. If left-turn lamps do not light, repair steering column connector and turn signal switch (para 2-27).
- c. If hazard warning flashers are inoperative, replace hazard warning switch (para 2-27).

2-20. LIGHT SYSTEMS TROUBLESHOOTING (CONT)

MALFUNCTION

TEST OR INSPECTION

CORRECTIVE ACTION

4. HEADLIGHTS INOPERATIVE

- Step 1. Pull out headlight switch fully.
Check if all lights are inoperative.
Press dimmer switch to check operation of low and high beam headlights.
- a. If all lights are inoperative, go to step 7 below.
 - b. If both headlights are inoperative and all other lights function properly, go to step 2 below.
- Step 2. Use an ohmmeter to check for continuity of low and high beam connections at each headlight.
- a. If bulbs are defective, replace (para 2-31a).
 - b. If bulbs are not defective, go to step 3 below.
- Step 3. Pull out headlight switch fully.
Use a voltmeter to check for 12 Vdc at low and high beam terminals at each headlight.
- a. If voltmeter indicates 12 Vdc at both terminals, repair or replace ground lead at headlight plug (para 2-31a).
 - b. If voltmeter indicates zero at all four terminals, go to step 4.
 - c. If voltmeter indicates zero at only one low beam terminal or only one high beam terminal, repair or replace headlight wiring (para 2-31a or 2-35b(1)).
 - d. If voltmeter indicates zero at both low beam or both high beam terminals, go to step 5 below.
- Step 4. Unplug dimmer switch connector (para 2-26a(5)).
Pull out headlight switch fully.
Use voltmeter to check for 12 Vdc at dimmer switch plug blue/orange electrical lead.
- a. If voltmeter indicates 12 Vdc, go to step 5 below.
 - b. If voltmeter indicates zero, go to step 6 below.

2-20. LIGHT SYSTEMS TROUBLESHOOTING (CONT)

MALFUNCTION

TEST OR INSPECTION

CORRECTIVE ACTION

4. HEADLIGHTS INOPERATIVE (Cont)

Step 5. Unplug dimmer switch connector (para 2-26a(5)).
Use an ohmmeter to check dimmer switch for continuity.

- a. If continuity is not obtained between center lug and each side lug, or continuity is obtained between any one lug and the case, replace dimmer switch (para 2-26a(5)).
- b. If correct continuity is obtained, go to step 6 below.

Step 6. Pull out headlight switch fully.
Use a voltmeter to check for 12 Vdc at headlight switch terminal blue/orange electrical lead.

- a. If voltmeter indicates 12 Vdc, repair or replace wiring between headlight switch and dimmer switch (para 2-35a(2) or 2-35c(1)).
- b. If voltmeter indicates zero, go to step 7 below.

Step 7. Use voltmeter to check for 12 Vdc at both terminals of headlight switch 30 ampere circuit breaker.

- a. If voltmeter indicates 12 Vdc at both terminals, replace headlight switch (para 2-26a(4)).
- b. If voltmeter indicates 12 Vdc only at battery side of 30 ampere circuit breaker, replace circuit breaker (para 2-26a(4)).
- c. If voltmeter indicates zero at both sides of 30 ampere circuit breaker, repair or replace wiring from 30 ampere circuit breaker to ammeter and batteries.

5. MARKER LIGHTS AND TAIL LIGHTS INOPERATIVE

Step 1. Pull out headlight switch fully.
Check operation of marker lights and tail lights.

- a. If all lights are inoperative, go to step 3 below.
- b. If one or more lights operate properly, go to step 2 below.

Step 2. Check for continuity of each inoperative light bulb.

- a. If a bulb is defective, replace (para 2-31b or 2-31e).
- b. If bulbs are okay, repair wiring (para 2-31b or 2-31e).

2-20. LIGHT SYSTEMS TROUBLESHOOTING (CONT)

MALFUNCTION

TEST OR INSPECTION

CORRECTIVE ACTION

5. MARKER LIGHTS AND TAIL LIGHTS INOPERATIVE (Cont)

Step 3. Pull out headlight switch fully.

Use voltmeter to check for 12 Vdc at both sides of 20A marker light circuit breaker.

- a. If voltmeter indicates 12 Vdc at both sides of 20A circuit breaker, repair or replace wiring between 20A circuit breaker and marker lights (para 2-35a(1), 2-35b(2), or 2-35c(1)).
- b. If voltmeter indicates 12 Vdc at only one side of 20A circuit breaker, replace 20A circuit breaker (para 2-35g).
- c. If voltmeter indicates zero at both sides of 20A circuit breaker, go to step 4 below.

Step 4. Pull headlight switch out to first detent position.

Use voltmeter to check for 12 Vdc at headlight switch blue electrical lead.

- a. If voltmeter indicates 12 Vdc, repair or replace wiring between headlight switch and 30 ampere circuit breaker (para 2-26a(4)).
- b. If voltmeter indicates zero, go to step 5 below.

Step 5. Use voltmeter to check for 12 Vdc at both terminals of headlight switch 30 ampere circuit breaker.

- a. If voltmeter indicates 12 Vdc at both terminals, replace headlight switch (para 2-26a(4)).
- b. If voltmeter indicates 12 Vdc only at battery side of 30 ampere circuit breaker, replace 30 ampere circuit breaker (para 2-26a(4)).
- c. If voltmeter indicates zero at both sides of 30 ampere circuit breaker, repair or replace wiring from 30 ampere circuit breaker to ammeter and batteries.

2-20. LIGHT SYSTEMS TROUBLESHOOTING (CONT)

MALFUNCTION

TEST OR INSPECTION

CORRECTIVE ACTION

1. WATER TEMP WARNING LIGHT AND BELL NOT OPERATING PROPERLY

Remove alarmstat sensor (para 2-32c).

Connect one lead of an ohmmeter to alarmstat sensor screw terminal and the other lead to alarmstat sensor case. Place alarmstat sensor in pan of water and heat to 210 degrees F.

Ohmmeter should not indicate continuity until water reaches approximately 210 degrees F.

- a. If continuity is not obtained until water temperature reaches approximately 210 degrees F, repair or replace alarmstat sensor electrical leads (para 2-35d).
- b. If continuity is obtained at lower temperatures, or continuity is not obtained at approximately 210 degrees F, replace alarmstat sensor (para 2-32c).

2. OIL PRESSURE WARNING LIGHT AND BELL NOT OPERATING PROPERLY

Step 1. Turn key switch to on position; shut down engine.

Disconnect water level sensor leads (para 2-29).

OIL PRESSURE warning lamp shall light and warning bell shall sound.

- a. If lamp lights and bell sounds, go to step 2 below.
- b. If lamp does not light and bell does not sound, go to step 3 below.

Step 2. Start engine.

Watch OIL PRESS gage and OIL PRESSURE warning light and bell.

Light should extinguish and bell should stop sounding when OIL PRESS gage indicates approximately 8-10 psi pressure.

- a. If light extinguishes and bell stops sounding, no further action required.
- b. If light does not extinguish and bell does not stop sounding, go to step 3 below.

Step 3. With engine stopped, use an ohmmeter to check oil pressure sensor and electrical leads for continuity.

- a. If continuity is not obtained, repair or replace electrical leads (para 2-35d).
- b. If continuity is obtained, replace oil pressure sender (para 2-32a).

2-20. LIGHT SYSTEMS TROUBLESHOOTING (CONT)

MALFUNCTION

TEST OR INSPECTION

CORRECTIVE ACTION

3. LOW FUEL INDICATOR LIGHT AND FUEL GAGE NOT OPERATING PROPERLY

Step 1. Check if fuel level sender is properly adjusted.

- a. If fuel level sender is not properly adjusted, adjust or replace (para 2-32b).
- b. If fuel level sender is properly adjusted, go to step 2 below.

Step 2. Check fuel level sender electrical leads for loose connections.
Use an ohmmeter to check fuel level sender electrical leads for continuity.

- a. If electrical connections are loose, tighten.
- b. If continuity is not obtained, repair or replace electrical leads (para 2-35b(2)).
- c. If continuity is obtained, replace fuel level sender (para 2-32b).

4. VEHICLE STOP LIGHTS WON'T OPERATE

Step 1. Check service brakes stop light switch electrical leads for loose connections (para 2-32f(1)).

- a. If connections are loose, tighten.
- b. If connections are not loose, go to step 2 below.

Step 2. Use an ohmmeter to check service brakes stop light switch electrical leads for continuity.

- a. If continuity is not obtained, repair or replace electrical leads (para 2-35d).
- b. If continuity is obtained, replace service brakes stop light switch (para 2-32f(1)).

5. TRAILER STOP LIGHTS WON'T OPERATE

Step 1. Check trailer hand brake stop light switch electrical leads for loose connections (para 2-32f(2)).

- a. If connections are loose, tighten.
- b. If connections are not loose, go to step 2 below.

2-21. LIGHT SYSTEMS TROUBLESHOOTING (CONT)

MALFUNCTION

TEST OR INSPECTION

CORRECTIVE ACTION

5. TRAILER STOP LIGHTS WON'T OPERATE (Cont)

Step 2. Use an ohmmeter to check trailer hand brake stop light switch electrical leads for continuity.

- a. If continuity is not obtained, repair or replace electrical leads (para 2-35c(1)).
- b. If continuity is obtained, replace trailer hand brake stop light switch (para 2-32f(2)).

2-22. HORN SYSTEM TROUBLESHOOTING

MALFUNCTION

TEST OR INSPECTION

CORRECTIVE ACTION

1. ELECTRIC HORN DOES NOT SOUND

Step 1. Turn key switch to on position.

Use a voltmeter to check for 12 Vdc at horn relay orange/black electrical lead (terminal B).

- a. If voltmeter indicates 12 Vdc, go to step 3 below.
- b. If voltmeter indicates zero, go to step 2 below.

Step 2. Use a voltmeter to check for 12 Vdc at both sides of horn 10A circuit breaker.

- a. If voltmeter indicates 12 Vdc at only one side of 10A circuit breaker, replace 10A circuit breaker (para 2-35g).
- b. If voltmeter indicates 12 Vdc at both sides of 10A circuit breaker, repair orange/black electrical lead (para 2-33a).
- c. If voltmeter indicates zero at both sides of 10A circuit breaker, repair or replace wiring from 10A circuit breaker to batteries.

Step 3. Connect jumper lead from horn relay green/orange electrical lead (terminal S) to ground; check if horn sounds.

- a. If horn sounds, repair horn switch (para 2-33b).
- b. If horn does not sound, go to step 4 below.

2-22. HORN SYSTEM TROUBLESHOOTING

MALFUNCTION
TEST OR INSPECTION
CORRECTIVE ACTION

1. ELECTRIC HORN DOES NOT SOUND (Cont)

Step 4. With terminal S grounded, use a voltmeter to check for 12 Vdc at horn relay blue electrical lead (terminal H).

- a. If voltmeter indicates less than 11 Vdc, replace horn relay (para 2-33a).
- b. If voltmeter indicates at least 11 Vdc, go to step 5 below.

Step 5. Connect jumper lead from horn body to ground.
Press horn button; horn should sound.

- a. If horn sounds, clean corrosion from horn bracket (para 2-33a).
- b. If horn does not sound, go to step 6 below.

Step 6. Have assistant depress horn button.
Use a voltmeter to check for 12 Vdc at horn terminal (blue electrical lead).

- a. If voltmeter indicates 12 Vdc, replace horn (para 2-33a).
- b. If voltmeter indicates zero, repair electrical lead (para 2-33a).

2-23. BATTERY SYSTEM TROUBLESHOOTING

MALFUNCTION
TEST OR INSPECTION
CORRECTIVE ACTION

1. BATTERIES REQUIRE FREQUENT FILLING

Step 1. Run engine at 1200 rpm and watch voltmeter.

- a. If voltmeter pointer is within green arc, go to step 2 below.
- b. If voltmeter pointer is above green arc, shut down engine and refer to para 2-17, Malfunction 1.

Step 2. Inspect battery cases for damage.

- a. If battery cases are damaged, replace batteries (para 2-34a).
- b. If cases are not damaged, refer to para 2-17, Malfunction 1.

2-23. BATTERY SYSTEM TROUBLESHOOTING (CONT)
--

MALFUNCTION

TEST OR INSPECTION

CORRECTIVE ACTION

2. BATTERIES FAIL TO MAINTAIN CHARGE

Step 1. Turn key switch to on position.

Pull out headlight switch to first detent position.

With engine shut down, note voltmeter indication.

Then start engine, run at 1200 rpm, and watch voltmeter.

- a. If voltmeter pointer does not move from lower green arc to upper green arc when engine is run, go to step 3 below.
- b. If voltmeter pointer moves from lower green arc to upper green arc when engine is run, go to step 2 below.

Step 2. Pull out headlight switch to first detent position.

Start engine and run at 1200 rpm; immediately watch ammeter pointer.

- a. If ammeter indicates plus (+) side of zero, go to step 5 below.
- b. If ammeter does not indicate plus (+) side of zero, go to step 3 below.

WARNING

Battery electrolyte is toxic and corrosive. Use protective goggles and gloves when performing the following. Avoid contact with skin, eyes, clothes, and don't breathe vapors.

Step 3. Check level of electrolyte in batteries.

- a. If electrolyte level is below plates of any cell, add distilled water to bring level 3/8 inch above plates (para 2-34a).
- b. If electrolyte level is okay, go to step 4 below.

Step 4. Check for loose battery cables or broken battery terminal lugs.

- a. If battery cables are loose, tighten (paragraph 2-34a).
- b. If battery terminal lugs are broken, replace (para 2-34a).
- c. If battery cables and terminal lugs are okay, go to step 5.

Step 5. Inspect battery posts and terminal lugs for corrosion.

- a. If corrosion is observed, remove (para 2-34a).
- b. If corrosion is not observed, refer to para 2-17, Malfunction 2.

2-24. ALTERNATOR MAINTENANCE

- This task covers:
- a. Testing
 - b. Removal
 - c. Drive disassembly
 - d. Cleaning
 - e. Inspection
 - f. Drive reassembly
 - g. Installation

INITIAL SETUP

Tools

No. 1 Common Organizational Maintenance

Tool Kit

- Socket wrench set
- Safety glasses
- Combination wrench set
- Torque wrench
- Scratch wire brush
- Puller kit

- Soft mallet
- Voltmeter
- Ammeter
- Carbon pile
- Arbor press

2-34a

Personnel Required

Wheel Vehicle Mechanic MOS 63B

Equipment Condition

Paragraph Condition Description

Vehicle parked on level surface, engine off, and parking brake applied. Cab tilted 45 degrees. Battery ground cable disconnected.

Materials/Parts

- Cleaning solvent Item 1, Appendix C
- Clean cloths Item 2, Appendix C
- Detergent Item 27, Appendix C
- Grease Item 34, Appendix C
- Gasket FSCM 72582 PN 5103476

STEP	LOCATION	ITEM	ACTION	REMARKS
------	----------	------	--------	---------

NOTE

Notify direct support maintenance for replacement and repair of drive support assembly (TM 9-2815-205-34).

REMOVAL

- | | | | | |
|---|--------------------------|--|--|--|
| 1 | Alternator, bottom, rear | <ul style="list-style-type: none"> a. Capscrew (5) b. Two ground wires (8 and 10) c. Capscrew (5) | <ul style="list-style-type: none"> Remove Disconnect | Finger tight |
| 2 | Alternator, top, rear | <ul style="list-style-type: none"> a. Boot (19) b. Nut (23) and lock washer (2) | <ul style="list-style-type: none"> Position Remove | Slide up and over terminal and move back on wire (1) |

2-24. ALTERNATOR MAINTENANCE (CONT)

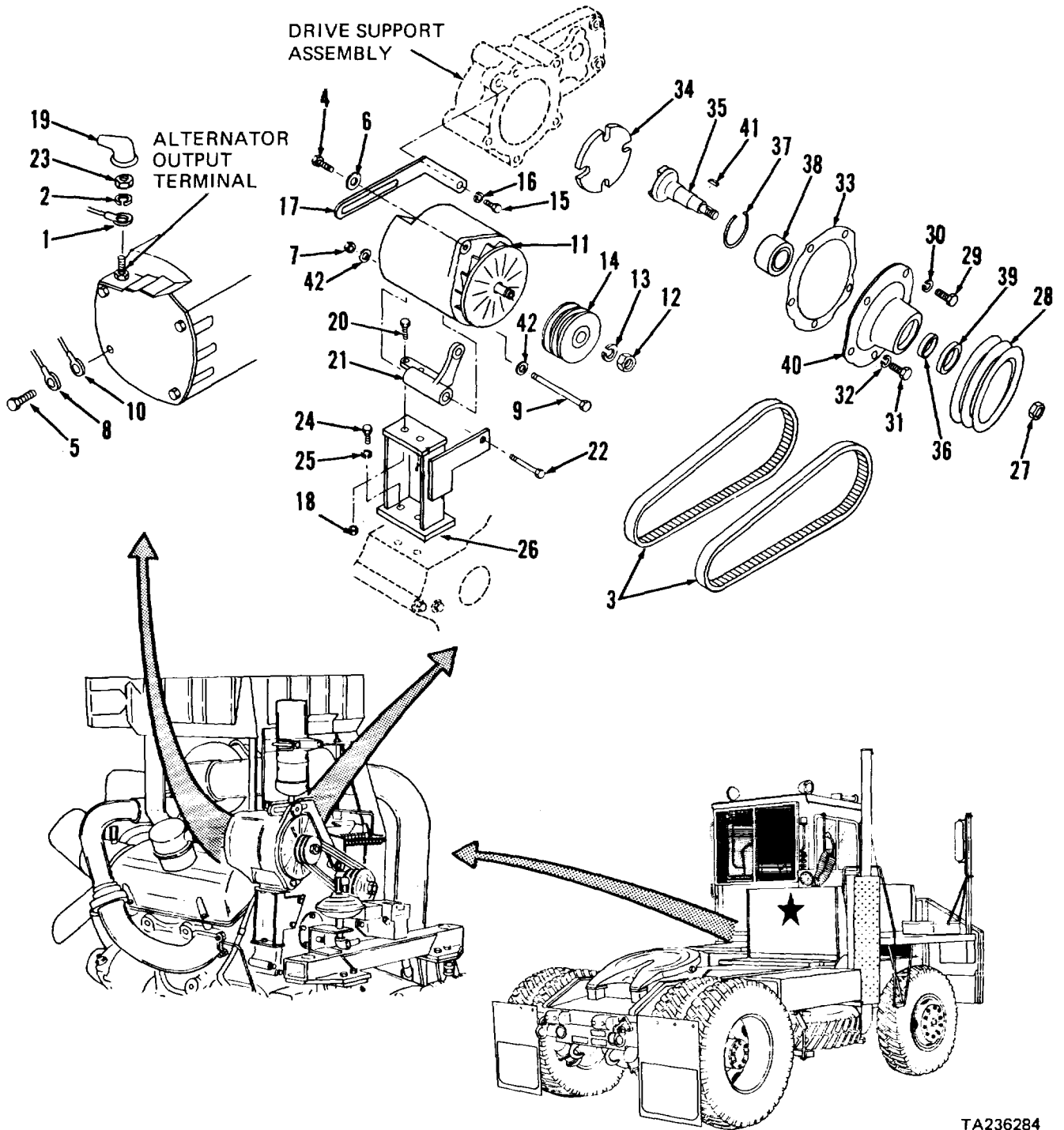

TA236284

2-24. ALTERNATOR MAINTENANCE (CONT)

KEY

- | | | |
|----------------------|------------------------|----------------------|
| 1. Fusible link wire | 15. Capscrew | 29. Capscrew |
| 2. Lock washer | 16. Lock washer | 30. Lock washer |
| 3. Belts (2) | 17. Adjusting strap | 31. Capscrews (4) |
| 4. Capscrew | 18. Nuts (2) | 32. Lock washers (4) |
| 5. Capscrew | 19. Boot | 33. Gasket |
| 6. Washer | 20. Capscrews (2) | 34. Coupling |
| 7. Nut | 21. Alternator bracket | 35. Drive shaft |
| 8. Ground wire | 22. Capscrew | 36. Spacer |
| 9. Capscrew | 23. Nut | 37. Retaining ring |
| 10. Ground wire | 24. Capscrews (2) | 38. Bearing |
| 11. Alternator | 25. Lock washers (2) | 39. Oil seal |
| 12. Nut | 26. Support bracket | 40. Retainer |
| 13. Lock washer | 27. Nut | 41. Key |
| 14. Pulley | 28. Pulley | 42. Washers (2) |

STEP	LOCATION	ITEM	ACTION	REMARKS		
REMOVAL (cont)						
2 (cont)		c. Fusible link wire (1)	Disconnect			
		d. Capscrew (4) and nut (7)	Loosen			
		e. Alternator (11)	Move	Swing toward alternator drive assembly (35 thru 40)		
		f. Two belts (3)	Remove			
		g. Capscrew (4) and washer (6)	Remove			
		h. Capscrew (15)	Loosen			
		i. Adjusting strap (17)	Move up			
		j. Nut (7), two washers (42), and capscrew (9)	Remove	Support alternator (11)		
		k. Alternator (11)	Remove			
		3	Alternator (11)	a. Nut (12) and lock washer (13)	Remove	
				b. Pulley (14)	Remove	Tap with soft mallet to loosen; then use suitable puller
c. Nut (12) and lock washer (13)	Reinstall			Finger tight on alternator		

2-24. ALTERNATOR MAINTENANCE (CONT)

STEP	LOCATION	ITEM	ACTION	REMARKS
REMOVAL (cont)				
4	Engine, left rear side	a. Capscrew (15), lock washer (16), and adjusting strap (17)	Remove	
		b. Two nuts (18) and capscrews (20)	Remove	
		c. Alternator bracket (21)	Remove	
		d. Capscrew (22)	Remove	
		e. Two capscrews (24) and lock washers (25)	Remove	
		f. Support bracket (26)	Remove	
5	Alternator drive as- sembly (35 thru 40)	a. Nut (27)	Remove	Tap with soft mallet to loosen; then use suitable puller
		b. Pulley (28) and key (41)	Remove	
		c. Capscrew (29) and lock washer (30)	Remove	
		d. Four capscrews (31) and lock washers (32)	Remove	
		e. Alternator drive assem- bly (35 thru 40)	Remove	
		f. Coupling (34)	Remove	
		g. Gasket (33)	Remove and discard	
DISASSEMBLY				
6	Alternator drive as-(35) sembly (35 thru 40)	a. Drive shaft	Remove	Place retainer (40) in arbor press and press out shaft
		b. Spacer (36)	Remove	From retainer (40)
		c. Retaining ring (37)	Remove	From retainer (40)
		d. Bearing (38) and oil seal (39)	Remove	

2-24. ALTERNATOR MAINTENANCE (CONT)

STEP	LOCATION	ITEM	ACTION	REMARKS
CLEANING				
7		a. Two belts (3)	Clean	Wipe with clean cloth moistened with detergent
<u>WARNING</u>				
<p>Dry cleaning solvent (P-D-680), used to clean parts is toxic and flammable. Wear protective goggles and gloves and use only in a well ventilated area. Avoid contact with skin, eyes, and clothes and don't breathe vapors. Do not use near open flame or excessive heat and don't smoke when using it. Failure to do so could cause serious injury. If you become dizzy while using cleaning solvent, get fresh air and medical attention immediately. If contact with skin or clothes is made, flush with large amounts of water. If contact with eyes is made, wash eyes with water and seek medical aid immediately.</p> <p>Compressed air must not exceed 30 psi. Wear safety glasses when drying parts with compressed air. Failure to do so could cause serious injury to eyes and possible blindness. If you hurt your eyes or if a foreign object is blown into your eyes, seek medical attention immediately.</p>				
		b. Alternator (11)	Clean	Wipe with clean cloth moistened with cleaning solvent P-D-680; dry with clean cloths
		c. Pulleys (14 and 28)	Clean	Use cleaning solvent P-D-680 and stiff bristled brush; dry with compressed air
		d. All other parts	Clean	Use cleaning solvent P-D-680; dry with compressed air
INSPECTION				
8		a. Two belts (3)	Inspect	Replace as a set if cracked, worn, broken, frayed, or deteriorated
		b. Alternator (11)	Inspect	Inspect for broken terminals, bent shaft, or other external damage. Repair alternator if necessary (notify direct support maintenance)

2-24. ALTERNATOR MAINTENANCE (CONT)

STEP	LOCATION	ITEM	ACTION	REMARKS
INSPECTION (cont)				
8 (cont)		c. Adjusting strap (17), alternator bracket (21), and support bracket (26)	Inspect	Replace if cracked, broken, distorted, or otherwise damaged
		d. Pulleys (14 and 28)	Inspect	Replace if cracked, broken, distorted, or bores or sheaves worn
		e. Coupling (34), bearing (38), oil seal (39) and retainer (40)	Inspect	Replace if cracked, broken, or distorted
		f. All other parts	Inspect	Replace if cracked, broken distorted, or threads damaged
REASSEMBLY				
9	Alternator drive assembly (35 thru 40)(37)	a. Bearing (38)	Install	Press in retainer (40); use arbor press
		b. Retaining ring	Install	
		c. Oil seal (39)	a. Lubricate b. Install	Pack lip of seal with grease Press into retainer (40)
		d. Drive shaft (35)	Install	Use arbor press
		e. Spacer (36)	Install	
INSTALLATION				
10	Alternator drive assembly (35 thru 40)	a. Key (41)	Position	In drive shaft (35) keyway
		b. New gasket (33)	Position	On retainer (40)
		c. Coupling (34) and alternator drive assembly (35 thru 40)	Install	
		d. Four lock washers (32) and capscrews (31)	Install	
		e. Lock washer (30) and cap-screw (29)	Install	

2-24. ALTERNATOR MAINTENANCE (CONT)

STEP	LOCATION	ITEM	ACTION	REMARKS
INSTALLATION (cont)				
10 (cont)		f. Pulley (28)	Install	
		g. Nut (27)	Install	Tighten to 120-140 pounds foot torque
11	Engine, left rear side	a. Support bracket (26)	Position	
		b. Two lock wash- ers (25) and capscrews (24)	Install	
		c. Capscrew (22)	Install	
		d. Alternator bracket (21)	Position	
		e. Two capscrews (20) and nuts (18)	Install	
		f. Adjusting strap (17)	Position	
		g. Lock washer (16) and cap- screw (15)	Install	
		h. Alternator (11)	Position; then support	On support bracket (26)
		i. Capscrew (9), two washers (42), nut (7)	Install and tighten and	
		j. Washer (6) and capscrew (4)	Install	Finger tighten
12 (11)	Alternator	a. Pulley (14)	Install	
		b. Lock washer (13) and nut (12)	Install and tighten	
		c. Two belts (3)a. b.	Position Adjust	In pulley sheaves Adjust tension so that a firm push with thumb midway be- tween pulleys will deflect belts 1/2 to 3/4 inch
		d. Washer (6) and capscrew (4)	Tighten	
		e. Fusible link wire (1)	Connect	To alternator positive terminal
		f. Nut (23) and lock washer (2)	Install and tighten	On positive terminal of alternator

2-24. ALTERNATOR MAINTENANCE (CONT)

STEP	LOCATION	ITEM	ACTION	REMARKS
INSTALLATION (cont)				
12 (cont)		g. Boot (19)	Position	Over positive terminal
		h. Two ground wires (8 and 10)	Connect	To capscrew (5)
		i. Capscrew (5)	Install and tighten	Secures ground wires (8 and 10)

NOTE

The alternator rotor normally retains magnetism to provide voltage build-up (self-excitation) when engine is started. After installation, however, it may be necessary to reestablish magnetism in the rotor as described in the following step.

		j. Jumper lead	Connect momentarily	From battery positive post to alternator relay ("R") terminal to restore magnetism; then remove
TESTING				
13	Engine, left rear side	Ammeter	Connect	In series with wires connected from alternator output terminal
14	Battery box	a. Battery ground cable	Reconnect	Para 2-34a
		b. Carbon pile	Connect	Across batteries
15	Instrument panel	Key switch	Turn on and start engine	Operate engine at moderate speed to give alternator speed of 4000 rpm or more. Turn on all accessories to increase load on batteries
16	Engine, left rear side	Ammeter	Observe	If reading is within 10 amperes of rated output stamped on alternator frame, the integral charging unit is not defective If ampere output is not within in 10 amperes of rated output, remove alternator for repair (notify direct support maintenance)

2-24. ALTERNATOR MAINTENANCE (CONT)

STEP	LOCATION	ITEM	ACTION	REMARKS
TESTING (cont)				
17	Instrument panel	Key switch	Turn off	Turn off accessories
18	Battery box	a. Battery ground cable	Disconnect	Para 2-34a
		b. Carbon pile	Remove	
19	Engine, left rear side	a. Ammeter	Remove	From alternator output terminal to ground
		b. Voltmeter	Connect	
20	Instrument panel	Key switch	Turn on and start engine	Leave all accessories off. Increase engine speed to obtain maximum voltage reading
21	Engine, left rear	Voltmeter	Observe	If reading exceeds 15 volts, remove alternator for repair (notify direct support maintenance)
22	Instrument panel	Key switch	Turn off	
23	Engine, left rear side	Voltmeter	Disconnect	
24	Battery box	Battery ground cable	Connect	Para 2-34a

2-25. STARTING SYSTEM MAINTENANCE

a. Solenoid and 70 AMP Circuit Breaker.

This task covers:

- a. Removal
- b. Cleaning
- c. Inspection
- d. Installation
- e. Testing

INITIAL SETUP

Tools

No. 1 Common Organizational Maintenance
Tool Kit

- Socket wrench set
- Screwdriver
- Safety glasses
- Multimeter
- Torque wrench

Personnel Required

Two Wheel Vehicle Mechanics MOS 63B

Equipment Condition

Paragraph	Condition Description
2-34a	Parked on level surface; parking brake applied; engine off. Battery ground cable disconnected.

Materials/Parts

Cleaning solvent	Item 1,	Appendix C
Clean cloths	Item 2,	Appendix C
Tags	Item 14,	Appendix C
Detergent	Item 27,	Appendix C

KEY

1. Nuts (2)	12. Nut	23. Wire (BLK)	
2. Capscrews (2)	13. Washer	24. Nut	34. Screw
3. Shield	14. Terminal	25. Washer	35. Lock washer
4. Terminal	15. Wire (RED)	26. Terminal	36. Wire (RED)
5. Nut	16. Terminal	27. Bracket	37. Locknuts (2)
6. Lock washer	17. Screw	28. Nut	38. Washers (2)
7. Terminal	18. Lock washer	29. Lock washer	39. Screws (2)
8. Wire (BLK)	19. Terminal	30. Wire (TAN/GRN)	40. Circuit breaker
9. Nut	20. Nut	31. Solenoid	41. Capscrew
10. Terminal	21. Washer	32. Capscrews (2)	42. Lock washer
11. Wire (RED)	22. Terminal	33. Plate	43. Capscrew

STEP	LOCATION	ITEM	ACTION	REMARKS
------	----------	------	--------	---------

REMOVAL

1	Starter	a. Two nuts (1) and capscrews (2)	Remove	Support shield (3)
		b. Shield (3)	Remove	

NOTE

Tag and identify all wires before disconnecting them to aid in reinstallation.

2-25. STARTING SYSTEM MAINTENANCE (CONT)

a. Solenoid and 70 AMP Circuit Breaker (cont).

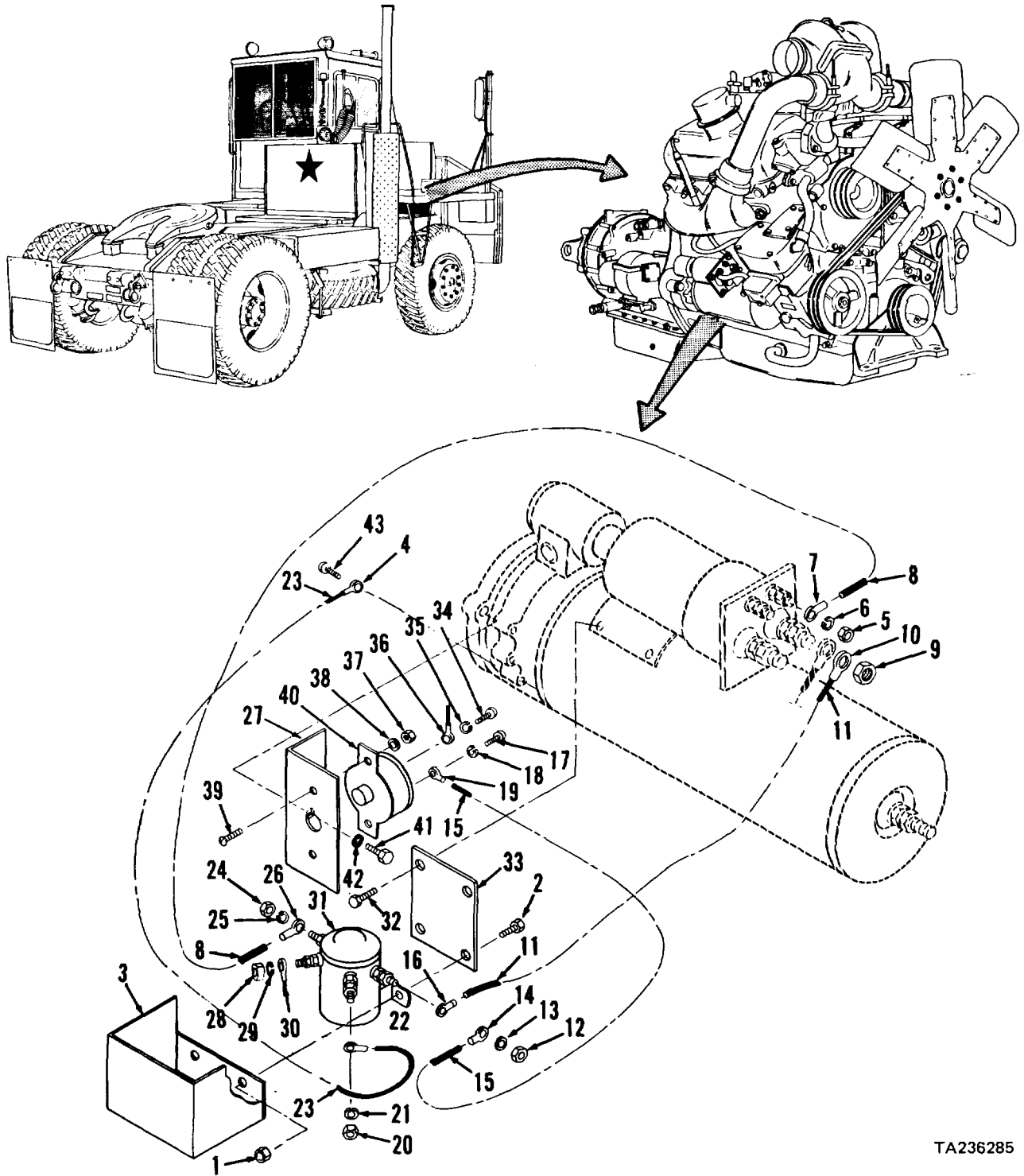

TA236285

2-25. STARTING SYSTEM MAINTENANCE (CONT)

a. Solenoid and 70 AMP Circuit Breaker (cont).

STEP	LOCATION	ITEM	ACTION	REMARKS
REMOVAL (cont)				
1 (cont)		c. Capscrew (43) and terminal (4)	Remove	
		d. Nut (5) and lock washer (6)	Remove	
		e. Terminal (7) and black wire (8)	Disconnect	
		f. Nut (9)	Remove	
		g. Terminal (10) and red wire (11)	Disconnect	
		h. Nut (12) and washer (13)	Remove	
		i. Terminal (14) and red wire (15)	Disconnect	
		j. Terminal (16) and red wire (11)	Disconnect and remove	
		k. Screw (17) and lock washer (18)	Remove	
		l. Terminal (19) and red wire (15)	Disconnect and remove	
		m. Nut (20) and washer (21)	Remove	
		n. Terminal (22) and black wire (23)	Disconnect and remove	
		o. Nut (24) and washer (25)	Remove	
		p. Terminal (26) and black wire (8)	Disconnect and remove	
		q. Nut (28) and lock washer (29)	Remove	
		r. Tan/green wire (30)	Disconnect	
		s. Solenoid (31)	Remove	

2-25. STARTING SYSTEM MAINTENANCE (CONT)

a. Solenoid and 70 AMP Circuit Breaker (cont).

STEP	LOCATION	ITEM	ACTION	REMARKS
REMOVAL (cont)				
1		t. Two capscrews (cont)(32)	Remove	Support plate (33)
		u. Plate (33)	Remove	
		v. Screw (34) and lock washer (35)	Remove	
		w. Red wire (36)	Disconnect	
		x. Two locknuts (37), washers (38), and screws (39)	Remove	
		y. Circuit breaker (40)	Remove	
		z. Capscrew (41), lock washer (42), and bracket (27)	Remove	
CLEANING				
2		a. Wires	Clean	Use clean cloth moistened with detergent; wipe dry using clean cloths

WARNING

Dry cleaning solvent (P-D-680), used to clean parts is toxic and flammable. Wear protective goggles and gloves and use only in a well ventilated area. Avoid contact with skin, eyes, and clothes and don't breathe vapors. Do not use near open flame or excessive heat and don't smoke when using it. Failure to do so could cause serious injury. If you become dizzy while using cleaning solvent, get fresh air and medical attention immediately. If contact with skin or clothes is made, flush with large amounts of water. If contact with eyes is made, wash eyes with water and seek medical aid immediately.

b. Solenoid (31) and circuit breaker (40)	Clean	Use clean cloth moistened with cleaning solvent P-D-680; dry using clean cloths
c. Remaining parts	Clean	Use cleaning solvent P-D-680; dry using clean cloths

2-25. STARTING SYSTEM MAINTENANCE (CONT)

- a. Solenoid and 70 AMP Circuit Breaker (cont).

STEP	LOCATION	ITEM	ACTION	REMARKS
INSPECTION				
3		a. Wires	Inspect for insulation cracked frayed terminals missing	Replace if defects observed
		b. Terminals	Inspect for damage corrosion	Replace if defects observed
		c. Shield (3), plate (33), and bracket (27)	Inspect for cracks breaks bent condition	Replace if defects observed
		d. Solenoid (31) and circuit breaker (40)	Inspect for damaged terminals loose terminals	Replace if defects observed
		e. Remaining parts	Inspect for cracks breaks distortion damaged threads	Replace if defects observed
INSTALLATION				
4	Starter	a. Bracket (27)	Position	On starter
		b. Lock washer (42) and capscrew (41)	Install and tighten	
		c. Red wire (36)	Connect	To circuit breaker (40)
		d. Lock washer (35) and screw (34)	Install and tighten	
		e. Circuit breaker (40)	Position	On bracket (27)
		f. Two screws (39), washers (38), and locknuts (37)	Install and tighten	Secures circuit breaker (40)

2-25. STARTING SYSTEM MAINTENANCE (CONT)

a. Solenoid and 70 AMP Circuit Breaker (cont).

STEP	LOCATION	ITEM	ACTION	REMARKS
INSTALLATION (cont)				
4 (cont)		g. Terminal (19) and red wire (15)	Connect	To circuit breaker (40)
		h. Lock washer (18) and screw (17)	Install and tighten	Secures terminal (19)
		i. Plate (33)	Position	On starter
		j. Two capscrews (32)	Install and tighten	Secures plate (33)
		k. Solenoid (31)	Support	
		l. Terminal (26) and black wire (8)	Connect	To solenoid (31)
		m. Washer (25) and nut (24)	Install and tighten	
		n. Tan/green wire (30)	Connect	To solenoid (31)
		o. Lock washer (29) and nut (28)	Install and tighten	
		p. Terminal (22) and black wire (23)	Connect	To solenoid (31)
		q. Washer (21) and nut (20)	Install and tighten	
		r. Terminal (16) and red wire (11)	Connect	To solenoid (31)
		s. Terminal (14) and red wire (15)	Connect	To solenoid (31)
		t. Washer (13) and nut (12)	Install and tighten	
		u. Terminal (4) and capscrew (43)	Install	Tighten to 13-17 pounds foot
		v. Shield (3)	Position	
		w. Two capscrews (2) and nuts (1)	Install and tighten	Connect terminal (4) of black wire (23) to one capscrew
		x. Terminal (7) and black wire (8)	Connect	To starter solenoid
		y. Lock washer (6) and nut (5)	Install and tighten	

2-25. STARTING SYSTEM MAINTENANCE (CONT)

- a. Solenoid and 70 AMP Circuit Breaker (cont).

STEP	LOCATION	ITEM	ACTION	REMARKS
INSTALLATION (cont)				
4 (cont)		z. Terminal (10) and red wire (11)	Connect	To starter solenoid
		aa. Nut (9)	Install and tighten	
5	Battery box	Battery ground cable	Connect	Para 2-34a
TESTING				
6	Battery box	Battery ground cable	Disconnect	Para 2-34a
7	Starter	a. Two nuts (1) and cap- screws (2)	Remove	
		b. Shield (3)	Remove	
8	Battery box	Battery ground cable	Connect	Para 2-34a

NOTE

In the following steps two technicians are required; one in the cab to operate key switch and the other to watch starter solenoid.

9	Cab	Key switch	Place in START position	
10	Starter	a. Starter solenoid	Observe that starter solenoid pulls in.	
			a. If it does not, check for voltage at solenoid (31) control terminal (tan/green wire) with key switch in START position	
			b. If voltage is 11 volts or more, proceed to step 10b below	
			c. If voltage is less than 11 volts, check battery system voltage (para 2-34a). If battery system voltage is normal, check vehicle wiring. If battery system voltage is not normal, replace batteries (para 2-34a)	
			d. If voltage is zero, check circuit breaker (40) (step 10c below)	

2-25. STARTING SYSTEM MAINTENANCE (CONT)

- a. Solenoid and 70 AMP Circuit Breaker (cont).

STEP	LOCATION	ITEM	ACTION	REMARKS
TESTING (cont) 10 (cont)		b. Ground wire (23)	Check for open ground wire. a. If ground wire (23) is open, replace	
		c.	b. If ground wire is okay, check for voltage at terminal (26) connected to solenoid (31) large terminal If voltage is present when key switch is in START position, check starter (para 2-25b) d. If voltage is not present when key switch is in START position, solenoid (31) is defective and must be replaced c. Circuit Check for voltage at terminal to which red breaker (40) wire (15) is connected. a. If voltage is present, check for voltage at circuit breaker (40) terminal to which red wire (36) is connected. If voltage is not present, press circuit breaker red button and recheck for voltage. If voltage is not present replace circuit breaker (40). If red button pops out, a short circuit exists in the wiring and must be located and repaired b. If voltage is not present, check red wire (15) connected to solenoid (31) for an open condition. If wire (15) is okay, check wire (11) and cable connected to battery; repair as necessary	
11	Battery box	Battery ground cable	Disconnect	Para 2-34a
12	Starter	a. Shield (3) b. Two capscrews (2) and nuts (1)	Position Install and tighten	Over solenoid (31)
13	Battery box	Battery ground cable	Connect	Para 2-34a

2-25. STARTING SYSTEM MAINTENANCE (CONT)

b. Starter.

This task covers:

- a. Removal
- b. Cleaning
- c. Inspection
- d. Installation
- e. Testing

INITIAL SETUP

Tools

No. 1 Common Organizational Maintenance

Tool Kit

- Socket wrench set
- Adjustable open end wrench
- Safety glasses
- Scratch wire brush
- Multimeter

Personnel Required

Two Wheel Vehicle Mechanics MOS 63B

Equipment Condition

Paragraph Condition Description

Materials/Parts

- Cleaning solvent Item 1, Appendix C
- Clean cloths Item 2, Appendix C
- Tags Item 14, Appendix C
- Detergent Item 27, Appendix C
- Gasket FSCM 72582 PN 5130955

- 2-34a Parked on level surface; parking brake applied; engine off. Cab tilted 45 degrees. Battery ground cable disconnected.
- 2-25a Wires and leads disconnected. Solenoid and circuit breaker removed.

STEP	LOCATION	ITEM	ACTION	REMARKS
------	----------	------	--------	---------

REMOVAL

1	Starter (7)	a. Nut (1)	Remove	From starter (7)
		b. Ground strap (2)	Disconnect	
2	Air compressor	a. Capscrew (3) and lock washer (4)	Remove	
		b. Ground strap (2)	Disconnect and remove	
3	Starter (7)	a. Nut (5)	Remove	Support starter (7)
		b. Battery positive cable (6)	Disconnect	
		c. Capscrew (8), capscrew (9) and two lock washers (10)	Remove	
		d. Starter (7)	Remove	
		e. Gasket (11)	Remove and discard	

2-25. STARTING SYSTEM MAINTENANCE (CONT)

b. Starter (cont).

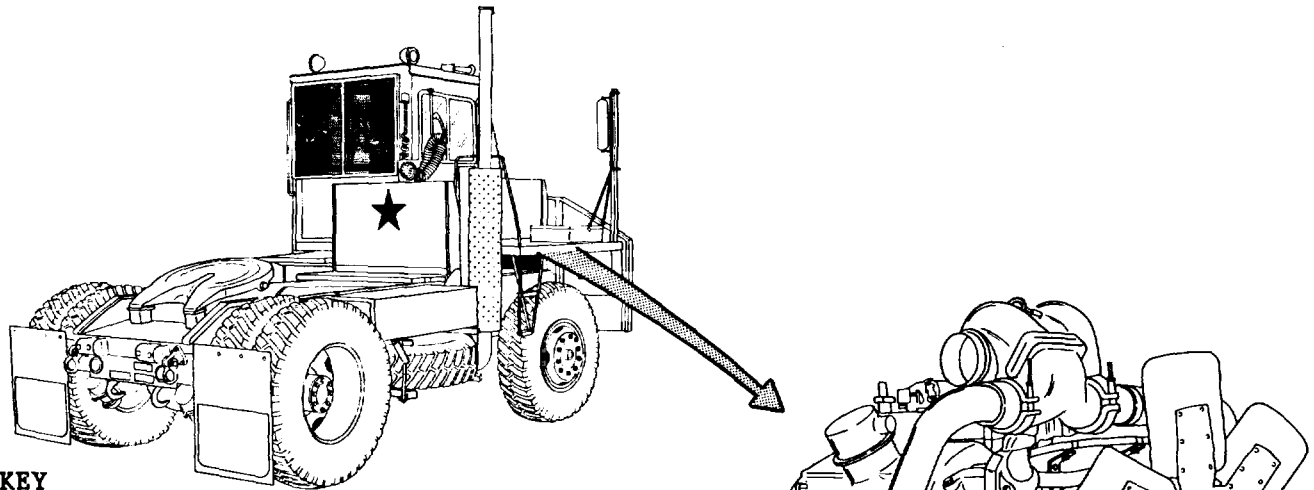

KEY

- 1. Nut
- 2. Ground strap
- 3. Capscrew
- 4. Lock washer
- 5. Nut
- 6. Battery positive cable
- 7. Starter
- 8. Capscrew (12 point)
- 9. Capscrew
- 10. Lock washers (2)
- 11. Gasket

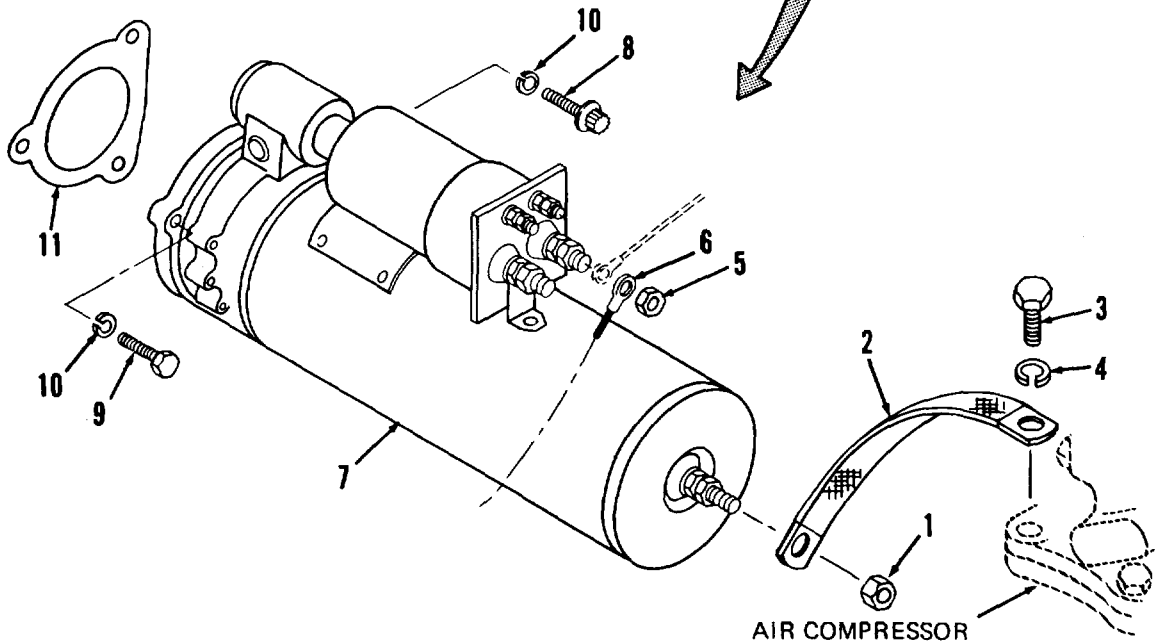

TA236286

2-25. STARTING SYSTEM MAINTENANCE (CONT)

b. Starter (cont).

STEP	LOCATION	ITEM	ACTION	REMARKS
CLEANING				
4		a. Battery positive cable (6)	Clean	Use clean cloth moistened with detergent; dry using clean cloth
<u>WARNING</u>				
Dry cleaning solvent (P-D-680), used to clean parts is toxic and flammable. Wear protective goggles and gloves and use only in a well ventilated area. Avoid contact with skin, eyes, and clothes and don't breathe vapors. Do not use near open flame or excessive heat and don't smoke when using it. Failure to do so could cause serious injury. If you become dizzy while using cleaning solvent, get fresh air and medical attention immediately. If contact with skin or clothes is made, flush with large amounts of water. If contact with eyes is made, wash eyes with water and seek medical aid immediately.				
		b. Starter (7)	Clean	Use clean cloth moistened with cleaning solvent P-D-680; dry using clean cloth
		c. Remaining parts	Clean	Use cleaning solvent P-D-680; dry using clean cloths
INSPECTION				
5		a. Battery positive cable (6)	Inspect for insulation cracked broken frayed terminals missing corroded damaged	Replace if defects observed
		b. Starter (7)	Inspect for cracks proper operation	Replace and repair if defective (notify direct support maintenance)
		c. Ground strap (2)	Inspect for cracks breaks frayed conductors	Replace if defects observed

2-25. STARTING SYSTEM MAINTENANCE (CONT)

b. Starter (cont).

STEP	LOCATION	ITEM	ACTION	REMARKS
INSPECTION (cont)				
5 (cont)		d. Remaining parts	Inspect for cracks breaks damaged threads	Replace if defects observed
INSTALLATION				
6	Engine, right side	a. New gasket (11) b. Starter (7) c. Two lock washers (10), capscrew (8), and cap- d. Ground strap (2) e. Capscrew (3) and lock washer (4) f. Ground strap (2) g. Nut (1) h. Solenoid and 70 ampere circuit breaker i. Battery positive cable (6) j. Nut (5)	Install Position Install and tighten position screw (9) Position Install and tighten Connect Install and tighten Install Position Install and tighten	Install capscrew (8) in hole located at one o'clock Between air compressor mount and starter (7) Secures ground strap (6) to air compressor mount To starter (7) terminal Para 2-25a Between battery and starter (7)
TESTING				
7	Engine, right side	Multimeter	Connect between terminal S of starter (7) solenoid and ground	
8	Cab	Key switch	Momentarily place in start position while an assistant observes multimeter	

2-25. STARTING SYSTEM MAINTENANCE (CONT)

b. Starter (cont).

STEP	LOCATION	ITEM	ACTION	REMARKS
TESTING (cont)				
9	Engine, right side	Multimeter	Watch	Multimeter should indicate more than 7.7 volts. If indication is less than 7.7 volts, use multimeter and check for excessive resistance in starter solenoid control circuit. Check and clean solenoid terminals using a wire brush and repeat this step

NOTE

If voltage exceeds 7.7 volts but starter does not pull in, the starter or solenoid is defective and must be removed and repaired. If the solenoid chatters but does not hold in, the solenoid is defective and must be replaced (notify direct support maintenance). If solenoid pulls in and starter gear engages the flywheel, but engine does not crank, or cranks slowly, first check for high resistance connections in battery circuit. If connections are okay, starter is defective and must be removed and repaired.

2-26. INSTRUMENT PANEL MAINTENANCE (CONT)

a. Switches (cont)

(1) Ignition Switch (cont).

This task covers:

- a. Removal
- b. Cleaning

- c. Inspection
- d. Installation

INITIAL SETUP

Tools

No. 1 Common Organizational Maintenance Tool Kit

- Adjustable open end wrench
- Socket wrench set
- Safety glasses

Equipment Condition

Paragraph	Condition Description
2-26g(1)	Vehicle parked on level surface, engine off, and parking brake applied.
2-34a	Instrument panel raised.
	Battery ground cable disconnected.

Materials/Parts

- | | |
|------------------|---------------------|
| Cleaning solvent | Item 1, Appendix C |
| Clean cloths | Item 2, Appendix C |
| Tags | Item 14, Appendix C |

Personnel Required

Wheel Vehicle Mechanic MOS 63B

KEY

- 1. Nuts (4)
- 2. Lock washers (4)
- 3. Electrical lead (ORG)
- 4. Electrical lead (ORG)
- 5. Electrical lead (TAN/BRN)
- 6. Electrical lead (BRN)
- 7. Electrical lead (BRN/YEL)
- 8. Electrical lead (BRN/WHT)
- 9. Key
- 10. Nut
- 11. Ignition switch
- 12. Nut
- 13. Tumbler

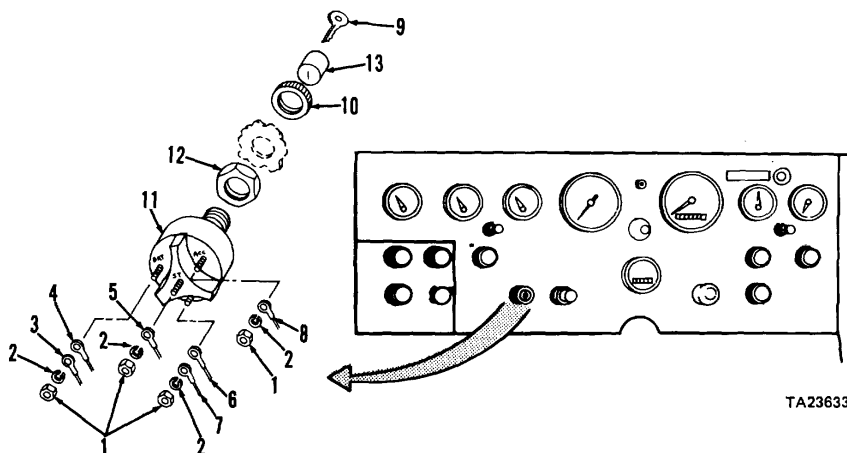

TA236333

2-26. INSTRUMENT PANEL MAINTENANCE (CONT)

a. Switches (cont)

(1) Ignition Switch (cont).

STEP	LOCATION	ITEM	ACTION	REMARKS
------	----------	------	--------	---------

REMOVAL

NOTE

Tag and identify all electrical leads before disconnection and removal.

1	Instrument panel	a. Six electrical leads (3 thru 8)	Tag	
		b. Four nuts (1) and lock washers (2)	Remove	
		c. Six electrical leads (3 thru 8)	Disconnect	
		d. Key (9)	Remove	From switch
		e. Nut (10)	Remove	Support ignition switch (11)
		f. Ignition switch (11)	Remove	From instrument panel
		g. Nut (12)	Remove	

NOTE

Perform step 2 below only if removal of tumbler (13) from ignition switch (11) is required.

2	Ignition switch (11)	a. Key (8)	Install	Rotate counterclockwise fully Insert a small screwdriver into slot of ignition switch (11) base. Depress tumbler (13) lock and pull tumbler out of switch
		b. Tumbler (13)	Remove	

CLEANING

3		a. Six electrical leads (3 thru 8)	Clean	Wipe with clean, dry cloth
---	--	------------------------------------	-------	----------------------------

2-26. INSTRUMENT PANEL MAINTENANCE (CONT)

a. Switches (cont)

(1) Ignition Switch (cont).

STEP	LOCATION	ITEM	ACTION	REMARKS
CLEANING (cont)				
3 (cont)			<u>WARNING</u>	
		<p>Dry cleaning solvent (P-D-680), used to clean parts is toxic and flammable. Wear protective goggles and gloves and use only in a well ventilated area. Avoid contact with skin, eyes, and clothes and don't breathe vapors. Do not use near open flame or excessive heat and don't smoke when using it. Failure to do so could cause serious injury. If you become dizzy while using cleaning solvent, get fresh air and medical attention immediately. If contact with skin or clothes is made, flush with large amounts of water. If contact with eyes is made, wash eyes with water and seek medical aid immediately.</p>		
		b. All other parts	Clean	Wipe with clean cloth moistened with cleaning solvent P-D-680; allow to air dry
INSPECTION				
4		All parts	Inspect	Replace if cracked, broken, insulation frayed, or threads damaged
INSTALLATION				
5	Instrument panel	a. Nut (12)	Install	On ignition switch (11)
		b. Tumbler (13)	Install	If removed. Depress tumbler (13) lock to install
		c. Ignition switch (11)	Position	In instrument panel, with key removed
		d. Nut (10)	Install and tighten	
		e. Electrical leads (3 and 4)	Connect	To BAT terminal of ignition switch (11)
		f. One nut (1) and lock washer (2)	Install and tighten	Secures leads (3 and 4)
		g. Electrical leads (6 and 7)	Connect	To IGN terminal of ignition switch (11)

2-26. INSTRUMENT PANEL MAINTENANCE (CONT)

a. Switches (cont)

(1) Ignition Switch (cont).

STEP	LOCATION	ITEM	ACTION	REMARKS
INSTALLATION (cont)				
5 (cont)		h. One nut (1) and lock washer (2)	Install and tighten	Secures leads (6 and 7)
		i. Electrical lead (8)	Connect	To ACC terminal of ignition switch (11)
		j. One nut (1) and lock washer (2)	Install and tighten	Secures lead (8)
		k. Electrical lead (5)	Connect	To ST terminal of ignition switch (11)
		l. One nut (1) and lock washer (2)	Install and tighten	Secures lead (5)
6	Cab	Instrument panel	Lower and secure	Para 2-26g(1)
7	Battery box	Battery ground cable	Connect	Para 2-34a

2-26. INSTRUMENT PANEL MAINTENANCE (CONT)

a. Switches (cont).

(2) Quick Start Switch.

This task covers:

- a. Removal
- b. Cleaning
- c. Inspection
- d. Installation

INITIAL SETUP

Tools

No. 1 Common Organizational Maintenance

Tool Kit

- Screwdriver
- Adjustable open end wrench
- Socket wrench set
- Screwdriver set
- Safety glasses
- Ohmmeter

Materials/Parts

- Cleaning solvent Item 1, Appendix C
- Clean cloths Item 2, Appendix C
- Tags Item 14, Appendix C

Personnel Required

Wheel Vehicle Mechanic MOS 63B

Equipment Condition

Paragraph Condition Description

Vehicle parked on level surface, engine off, and parking brake applied. Instrument panel raised. Battery ground cable disconnected.

2-26g(1)
2-34a

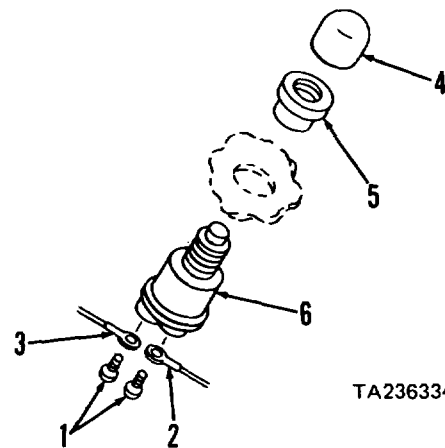
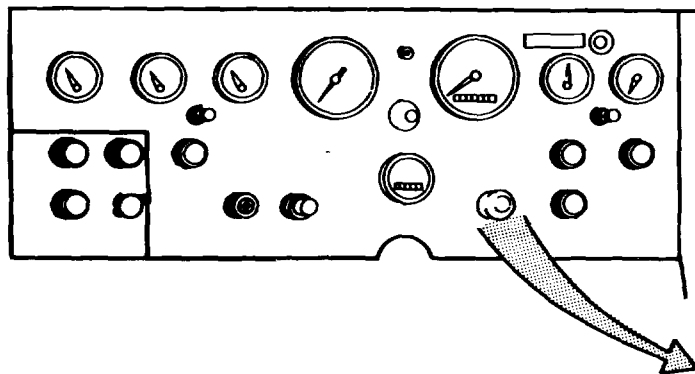

TA236334

KEY

- 1. Screws (2)
- 2. Electrical lead (YEL/BRN)
- 3. Electrical lead (BRN/WHT)
- 4. Rubber boot
- 5. Nut
- 6. Switch

2-26. INSTRUMENT PANEL MAINTENANCE (CONT)

a. Switches (cont).

(2) Quick Start Switch (cont).

STEP	LOCATION	ITEM	ACTION	REMARKS
------	----------	------	--------	---------

REMOVAL

NOTE

Tag and identify all electrical leads before disconnection and removal.

1	Instrument panel	a. Two electrical leads (2 and 3)	Tag	
		b. Two screws (1)	Remove	
		c. Two electrical leads (2 and 3)	Disconnect	
		d. Rubber boot (4)	Remove	From nut (5)
		e. Nut (5)	Remove	Support switch (6)
		f. Switch (6)	Remove	From instrument panel

CLEANING

2		a. Electrical leads (2 and 3), switch (6), and rubber boot (4)	Clean	Wipe with clean, dry cloth
---	--	--	-------	----------------------------

WARNING

Dry cleaning solvent (P-D-680), used to clean parts is toxic and flammable. Wear protective goggles and gloves and use only in a well ventilated area. Avoid contact with skin, eyes, and clothes and don't breathe vapors. Do not use near open flame or excessive heat and don't smoke when using it. Failure to do so could cause serious injury. If you become dizzy while using cleaning solvent, get fresh air and medical attention immediately. If contact with skin or clothes is made, flush with large amounts of water. If contact with eyes is made, wash eyes with water and seek medical aid immediately.

2-26. INSTRUMENT PANEL MAINTENANCE (CONT)

a. Switches (cont).

(2) Quick Start Switch (cont).

STEP	LOCATION	ITEM	ACTION	REMARKS
------	----------	------	--------	---------

CLEANING (cont)

WARNING

Compressed air must not exceed 30 psi. Wear safety glasses when drying parts with compressed air. Failure to do so could cause serious injury to eyes and possible blindness. If you hurt your eyes or if a foreign object is blown into your eyes, seek medical attention immediately.

b. All other parts	Clean	Use cleaning solvent P-D-680; dry thoroughly with compressed air
--------------------	-------	--

INSPECTION

3	a. Electrical leads (2 and 3)	Inspect	Replace if insulation frayed or wire connectors damaged
	b. Switch (6)	Inspect	Replace if cracked or broken. Check continuity with ohm-meter; replace if defective
	c. All other parts	Inspect	Replace if cracked, broken, deteriorated, or threads damaged

INSTALLATION

4	Instrument panel	a. Switch (6)	Position	In instrument panel opening	
		b. Nut (5)	Install and tighten		
		c. Rubber boot (4)	Install		Over nut (5)
		d. Two electrical leads (2 and 3)	Connect		
		e. Two screws (1)	Install and tighten		Secures leads (2 and 3)
5	Cab	Instrument panel	Lower and secure	Para 2-26g(1)	
6	Battery box	Battery ground cable	Connect	Para 2-34a	

2-26. INSTRUMENT PANEL MAINTENANCE (CONT)

a. Switches (cont).

(3) Engine Stop Switch.

This task covers:

- a. Removal
- b. Cleaning

- c. Inspection
- d. Installation

INITIAL SETUP

Tools

No. 1 Common Organizational Maintenance

Tool Kit

- Screwdriver
- Screwdriver set

Materials/Parts

Clean cloths

Tags

Item 2, Appendix C

Item 14, Appendix C

Equipment Condition

Paragraph

Condition Description

Vehicle parked on level surface, engine off, and parking brake applied.

2-26g(1)

Instrument panel raised.

2-34a

Battery ground cable disconnected.

Personnel Required

Wheel Vehicle Mechanic MOS 63B

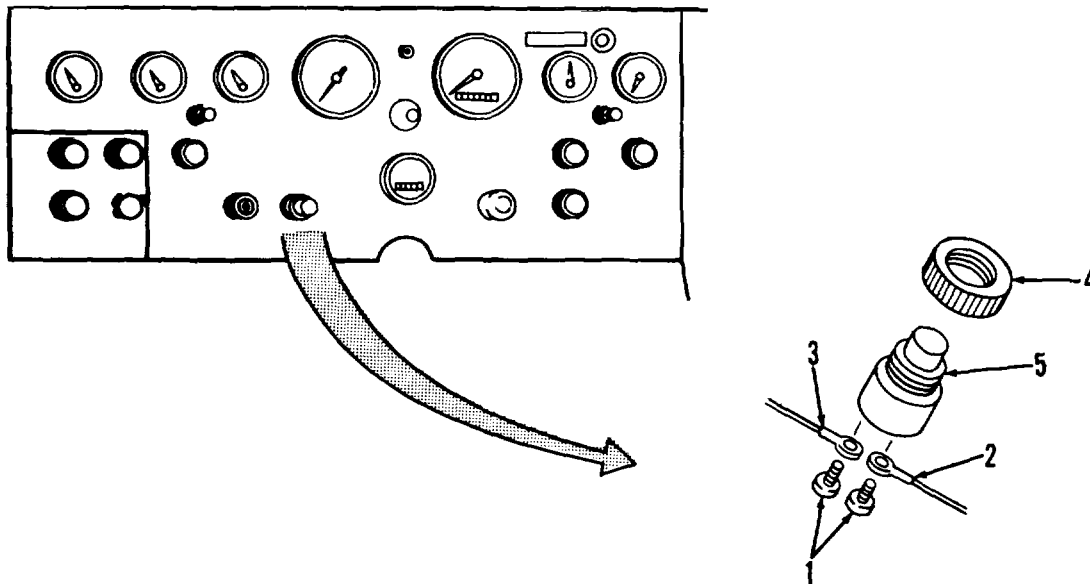

TA236335

KEY

- 1. Screws (2)
- 2. Electrical lead (YEL)
- 3. Electrical lead (ORG)
- 4. Nut
- 5. Engine stop switch

2-26. INSTRUMENT PANEL MAINTENANCE (CONT)

a. Switches (cont).

(3) Engine Stop Switch (cont).

STEP	LOCATION	ITEM	ACTION	REMARKS
REMOVAL				
NOTE				
Tag and identify all electrical leads before disconnection and removal.				
1	Instrument panel	a. Two electrical leads (2 and 3) b. Two screws (1) c. Two electrical leads (2 and 3) d. Nut (4) e. Engine stop switch (5)	Tag Remove Disconnect Remove Remove	 Support engine stop switch (5)
CLEANING				
2		All parts	Clean	Wipe with clean, dry cloth
INSPECTION				
3		All parts	Inspect	Replace if cracked, broken, or threads damaged
INSTALLATION				
4	Instrument panel	a. Engine stop switch (5) b. Nut (4) c. Two electrical leads (2 and 3) d. Two screws (1) e. Instrument panel	Position Install Position Install Lower and secure	In instrument panel Para 2-26g(1)
5	Battery box	Battery ground cable	Connect	Para 2-34a

2-26. INSTRUMENT PANEL MAINTENANCE (CONT)

a. Switches (cont).

(4) Headlight Switch and 30 Ampere Circuit Breaker.

This task covers: a. Removal c. Inspection
 b. Cleaning d. Installation

INITIAL SETUP

Tools

No. 1 Common Organizational Maintenance

Tool Kit

- Screwdriver
- Socket wrench set
- Safety glasses

Materials/Parts

- Cleaning solvent Item 1, Appendix C
- Clean cloths Item 2, Appendix C
- Tags Item 14, Appendix C

Personnel Required

Wheel Vehicle Mechanic MOS 63B

Equipment Condition

Paragraph	Condition Description
2-34a	Vehicle parked on level surface, engine off, and parking brake applied. Battery ground cable disconnected.
2-26g(1)	Instrument panel raised.

KEY

- | | |
|------------------------------|-------------------------------|
| 1. Nut | 9. Electrical lead (BLU/RED) |
| 2. Lock washer | 10. Electrical lead (BLU/ORG) |
| 3. Electrical lead (ORG/BLU) | 11. Electrical lead (BLU) |
| 4. Nut | 12. Setscrew |
| 5. Lock washer | 13. Knob |
| 6. 30A circuit breaker | 14. Nut |
| 7. Screws (3) | 15. Headlight switch |
| 8. Lock washers (3) | |

2-224

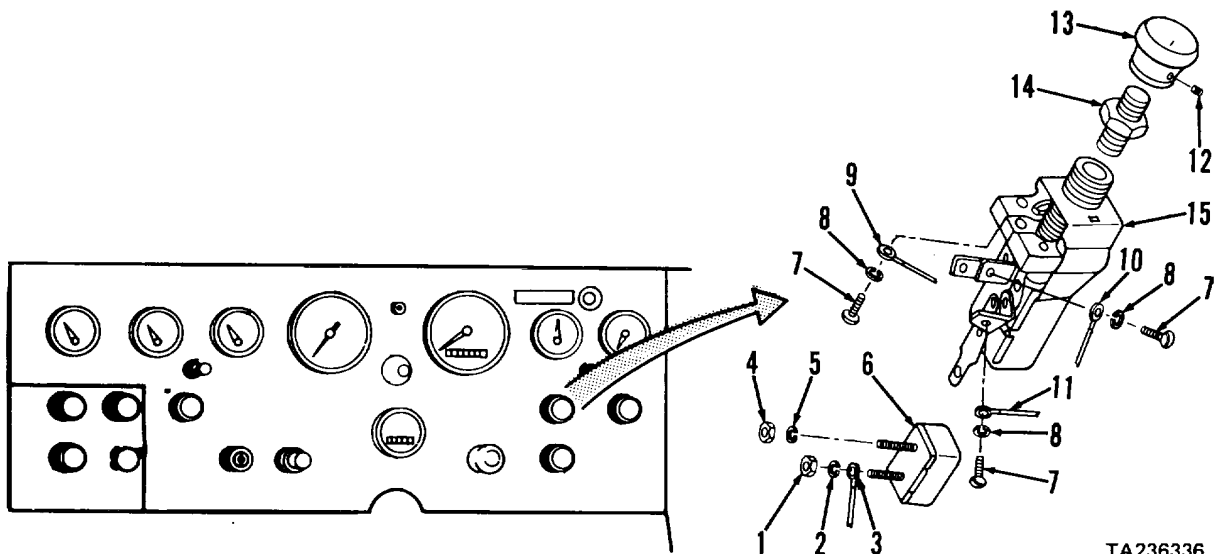

TA236336

2-224

2-26. INSTRUMENT PANEL MAINTENANCE (CONT)

a. Switches (cont).

(4) Headlight Switch and 30 Ampere Circuit Breaker (cont).

STEP	LOCATION	ITEM	ACTION	REMARKS
------	----------	------	--------	---------

REMOVAL

NOTE

Tag and identify all electrical leads before disconnection and removal.

1	Instrument panel, underside	a. Four electrical leads (3, 9, 10, and 11)	Tag	
		b. Nut (1) and lock washer (2)	Remove	From 30A circuit breaker (6)
		c. Electrical lead (3)	Disconnect	From 30A circuit breaker (6)
		d. Nut (4) and lock washer (5)	Remove	From 30A circuit breaker (6)
		e. 30A circuit breaker (6)	Remove	
		f. Three screws (7) and lock washers (8)	Remove	
		g. Three electrical leads (9 thru 11)	Disconnect	
		h. Headlight switch (15)	Support	
		i. Setscrew (12)	Loosen	
		j. Knob (13)	Remove	Rotate counterclockwise
		k. Nut (14)	Remove	
l. Headlight switch (15)	Remove			

CLEANING

2		a. Four electrical leads (3, 9, 10, and 11), 30A circuit breaker (6), knob (13), and headlight switch (15)	Clean	Wipe with clean, dry cloth
---	--	--	-------	----------------------------

2-26. INSTRUMENT PANEL MAINTENANCE (CONT)

a. Switches (cont).

(4) Headlight Switch and 30 Ampere Circuit Breaker (cont).

STEP	LOCATION	ITEM	ACTION	REMARKS
------	----------	------	--------	---------

CLEANING (cont)

WARNING

Dry cleaning solvent (P-D-680), used to clean parts is toxic and flammable. Wear protective goggles and gloves and use only in a well ventilated area. Avoid contact with skin, eyes, and clothes and don't breathe vapors. Do not use near open flame or excessive heat and don't smoke when using it. Failure to do so could cause serious injury. If you become dizzy while using cleaning solvent, get fresh air and medical attention immediately. If contact with skin or clothes is made, flush with large amounts of water. If contact with eyes is made, wash eyes with water and seek medical aid immediately.

Compressed air must not exceed 30 psi. Wear safety glasses when drying parts with compressed air. Failure to do so could cause serious injury to eyes and possible blindness. If you hurt your eyes or if a foreign object is blown into your eyes, seek medical attention immediately.

2
(cont)

b. All other parts
dry with compressed air

Clean

Use cleaning solvent P-D-680;

INSPECTION

3

a. Four electrical
leads (3, 9,
10, and 11)

Inspect

Replace if insulation frayed
or wire connectors damaged

b. 30A circuit
breaker (6)

Inspect

Replace if cracked, broken,
or threads damaged

c. Knob (13) and
headlight
switch (15)

Inspect

Replace if cracked, broken,
or otherwise damaged

d. All other parts

Inspect

Replace if cracked, broken,
distorted, or threads
damaged

2-26. INSTRUMENT PANEL MAINTENANCE (CONT)

a. Switches (cont).

(4) Headlight Switch and 30 Ampere Circuit Breaker (cont).

STEP	LOCATION	ITEM	ACTION	REMARKS
INSTALLATION				
4	Instrument panel	a. Headlight switch (15)	Position	In instrument panel
		b. Nut (14)	Install and tighten	
		c. Knob (13)	Install	Rotate clockwise
		d. Setscrew (12)	Tighten	
		e. Three electrical leads (9 thru 11)	Connect	
		f. Three lock washers (8) and screws (7)	Install	
		g. 30A circuit breaker (6)	Install	Battery terminal of 30A circuit breaker (6) must not be connected to headlight switch (15)
		h. Lock washer (5) and nut (4)	Install	
		i. Electrical lead (3)	Connect	To battery terminal of 30A circuit breaker (6)
		j. Lock washer (2) and nut (1)	Install	
5	Cab	Instrument panel	Lower and secure	Para 2-26g(1)
6	Battery box	Battery ground cable	Connect	Para 2-34a

2-26. INSTRUMENT PANEL MAINTENANCE (CONT)

a. Switches (cont).

(5) Dimmer Switch.

This task covers: a. Removal c. Inspection
 b. Cleaning d. Installation

INITIAL SETUP

Tools

No. 1 Common Organizational Maintenance

Tool Kit

Socket wrench set

Materials/Parts

Clean cloths Item 2, Appendix C

Personnel Required

Wheel Vehicle Mechanic MOS 63B

Equipment Condition

Paragraph Condition Description

Parked on level surface; parking brake applied; engine off.
 Floor mat pulled back from dimmer switch.

KEY

1. Wiring harness
2. Capscrews (2)
3. Lock washers (2)
4. Dimmer switch

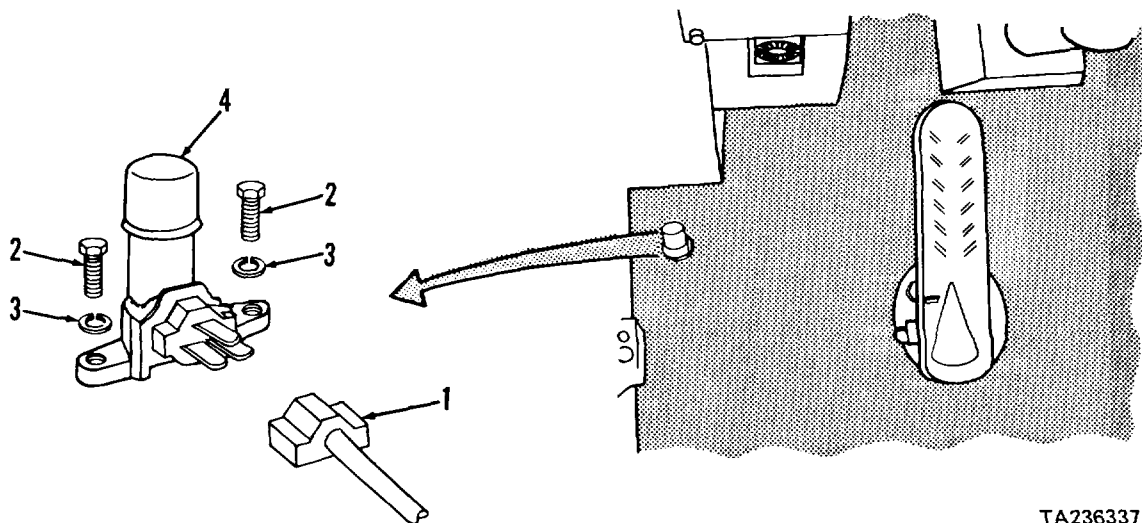

TA236337

2-26. INSTRUMENT PANEL MAINTENANCE (CONT)

a. Switches (cont).

(5) Dimmer Switch (cont).

STEP	LOCATION	ITEM	ACTION	REMARKS
REMOVAL				
1	Cab floor	a. Wiring harness (1)	Unplug	
		b. Two capscrews (2) and lock washers (3)	Remove	
		c. Dimmer switch (4)	Remove	
CLEANING				
2	All parts	Clean	Wipe with clean, dry cloth	
INSPECTION				
3		a. Wiring harness (1)	Inspect	Replace if insulation frayed or connectors damaged
		b. Dimmer switch (4)	Inspect inoperative	Replace if damaged or
		c. All other parts	Inspect	Replace if cracked, broken, distorted, or threads damaged
INSTALLATION				
4	Cab floor	a. Dimmer switch (4)	Position	
		b. Two lock washers (3) and capscrews (2)	Install and tighten	
		c. Wiring harness (1)	Connect	Push onto terminals of dimmer switch (4)
		d. Floor mat	Install	Lower over dimmer switch

2-26. INSTRUMENT PANEL MAINTENANCE (CONT)

a. Switches (cont).

(6) Flood Light Switches.

This task covers: a. Removal c. Inspection
 b. Cleaning d. Installation

INITIAL SETUP

Tools

No. 1 Common Organizational Maintenance
 Tool Kit
 Screwdriver
 Safety glasses
 Pliers, slip joint

Materials/Parts

Cleaning solvent Item 1, Appendix C
 Clean cloths Item 2, Appendix C
 Tags Item 14, Appendix C

Personnel Required

Wheel Vehicle Mechanic MOS 63B

Equipment Condition

Paragraph Condition Description

2-34a Vehicle parked on level surface, engine off, and parking brake applied.
 Battery ground cable disconnected.

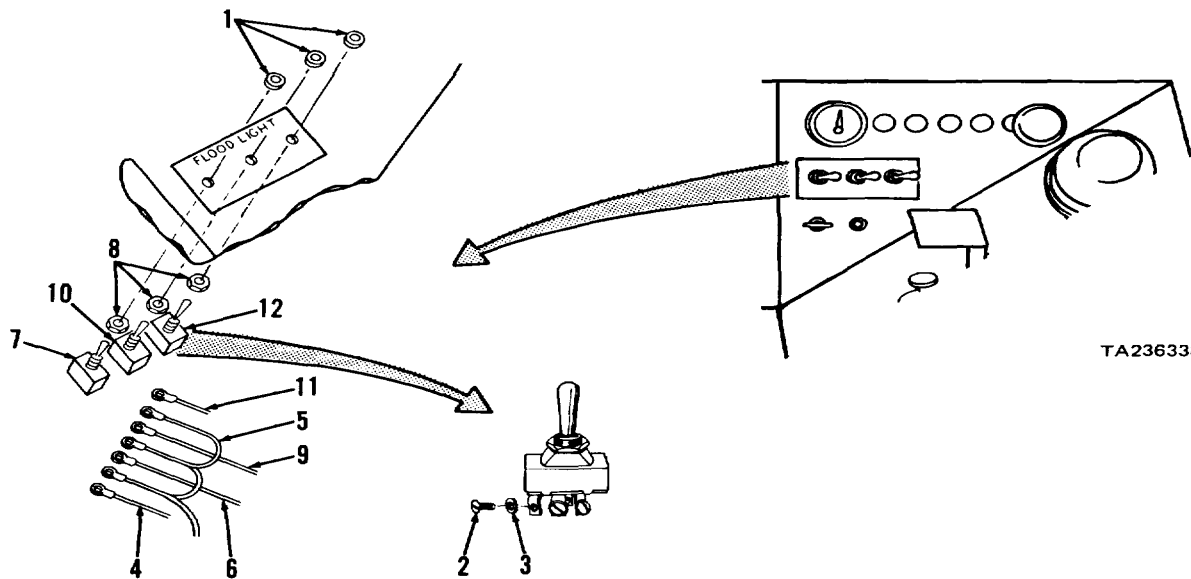

KEY

- 1. Chrome nuts (3)
- 2. Screws (6)
- 3. Washers (6)
- 4. Electrical lead (BRN/WHT)
- 5. Electrical lead (BRN/WHT)
- 6. Electrical lead (YEL/RED)
- 7. Switch
- 8. Nuts (3)
- 9. Electrical lead (GRN/RED)
- 10. Switch
- 11. Electrical lead (YEL/BLU)
- 12. Switch

2-26. INSTRUMENT PANEL MAINTENANCE (CONT)

a. Switches (cont).

(6) Flood Light Switches (cont).

STEP	LOCATION	ITEM	ACTION	REMARKS
REMOVAL				
1	Corner instrument panel	Three nuts (1)	Remove	From three switches (7, 10, and 12)
2	Cab tilt pump	Cab	Tilt 45 degrees	

NOTE

Tag and identify all electrical leads before disconnecting and removing.

3	Cab, underside	a. Five electrical leads (4, 5, 6, 9, and 11)	Tag	
		b. Two screws (2) and washers (3)	Remove	From floodlight switch (7); support switch
		c. Three electrical leads (4 thru 6)	Disconnect	
		d. Switch (7) and nut (8)	Remove and separate	
		e. Two screws (2) and washers (3)	Remove	From floodlight switch (10); support switch
		f. Two electrical leads (5 and 9)	Disconnect common ground	Electrical lead (5) is
		g. Switch (10) and nut (8)	Remove and separate	
		h. Two screws (2) and washers (3)	Remove support switch	From floodlight switch (12);
		i. Two electrical leads (5 and 11)	Disconnect	
		j. Switch (12) and nut (8)	Remove and separate	

2-26. INSTRUMENT PANEL MAINTENANCE (CONT)

a. Switches (cont).

(6) Flood Light Switches (cont).

STEP	LOCATION	ITEM	ACTION	REMARKS
CLEANING				
4		a. Five electrical leads (4, 5, 6, 9, and 11) and three switches (7, 10, and 12)	Clean	Wipe with clean, dry cloth
WARNING				
<p>Dry cleaning solvent (P-D-680), used to clean parts is toxic and flammable. Wear protective goggles and gloves and use only in a well ventilated area. Avoid contact with skin, eyes, and clothes and don't breathe vapors. Do not use near open flame or excessive heat and don't smoke when using it. Failure to do so could cause serious injury. If you become dizzy while using cleaning solvent, get fresh air and medical attention immediately. If contact with skin or clothes is made, flush with large amounts of water. If contact with eyes is made, wash eyes with water and seek medical aid immediately.</p> <p>Compressed air must not exceed 30 psi. Wear safety glasses when drying parts with compressed air. Failure to do so could cause serious injury to eyes and possible blindness. If you hurt your eyes or if a foreign object is blown into your eyes, seek medical attention immediately.</p>				
		b. All other parts	Clean	Use cleaning solvent P-D-680; dry with compressed air

INSPECTION

5		a. Five electrical leads (4, 5, 6, 9, and 11)	Inspect	Replace if insulation frayed or connectors damaged
		b. Three switches (7, 10, and 12)	Inspect	Replace if cracked, distorted, or inoperative

2-26. INSTRUMENT PANEL MAINTENANCE (CONT)

a. Switches (cont).

(6) Flood Light Switches (cont).

STEP	LOCATION	ITEM	ACTION	REMARKS
INSPECTION (cont)				
5 (cont)		c. All other parts	Inspect	Replace if cracked, broken, or threads damaged
INSTALLATION				
6	Switches (7, 10, and 12)	Three nuts (8)	Install	On three switches (7, 10, and 12)
7	Cab, underside	a. Two electrical leads (5 and 11)	Position	BRN/WHT lead (5) on center post of switch (12)
		b. Two screws (2) and washers (3)	Install and tighten	On switch (12)
		c. Two electrical leads (5 and 9)	Position	BRN/WHT lead (5) on center post of switch (10)
		d. Two screws (2) and washers (3)	Install and tighten	On switch (10)
		e. Three electri- cal leads (4 thru 6)	Position	BRN/WHT leads (4 and 5) on center post of switch (7)
		f. Two screws (2) and washers (3)	Install and tighten	On switch (7)
		g. Three switches (7, 10, and 12)	Position panel	In holes in corner instrument
8	Cab tilt pump	Cab	Lower	To normal operating position
9	Corner instrument panel	Three nuts (1)	Install and tighten	Rotate clockwise. Have assistant located under hood to hold switches stationary while nuts (1) are tightened with pliers
10	Battery box	Battery ground	Connect cable	Para 2-34a

2-26. INSTRUMENT PANEL MAINTENANCE (CONT)

a. Switches (cont).

(7) Trailer Light Switch.

This task covers:

- a. Removal
- b. Cleaning

- c. Inspection
- d. Installation

INITIAL SETUP

Tools

No. 1 Common Organizational Maintenance

Tool Kit

- Screwdriver
- Combination wrench set

Equipment Condition

Paragraph Condition Description

Materials/Parts

Clean cloths

Item 2, Appendix C

Tags

Item 14, Appendix C

Vehicle parked on level surface, engine off, and parking brake applied.
 2-26g(1) Instrument panel raised.
 2-34a Battery ground cable disconnected.

Personnel Required

Wheel Vehicle Mechanic MOS 63B

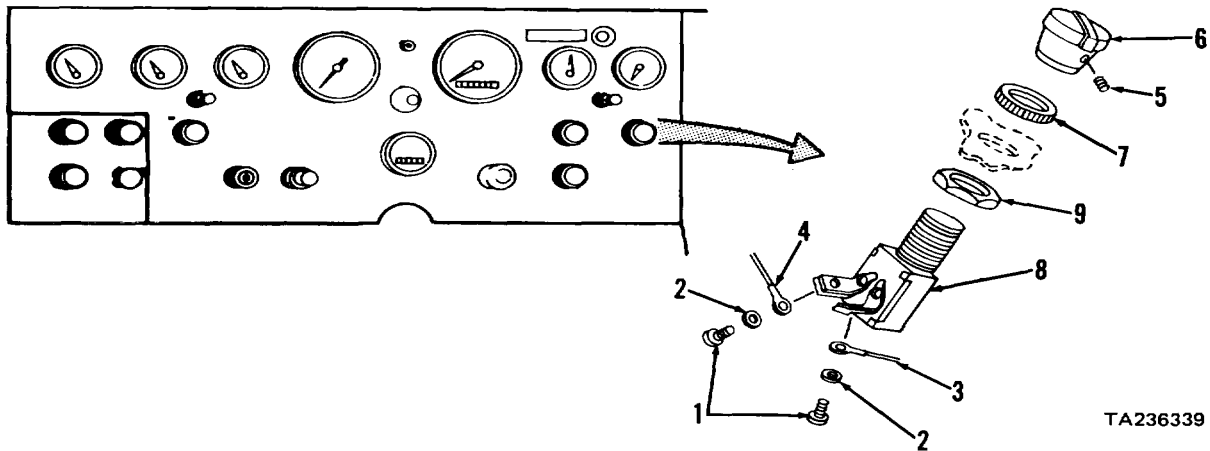

TA236339

KEY

- 1. Screws (2)
- 2. Washers (2)
- 3. Electrical lead (YEL/GRN)
- 4. Electrical lead (BRN/WHT)
- 5. Setscrew
- 6. Knob
- 7. Nut
- 8. Switch
- 9. Nut

2-26. INSTRUMENT PANEL MAINTENANCE (CONT)

a. Switches (cont).

(7) Trailer Light Switch (cont).

STEP	LOCATION	ITEM	ACTION	REMARKS
REMOVAL				
NOTE				
Tag and identify all electrical leads before disconnection and removal.				
1	Instrument panel	a. Two electrical leads (3 and 4)	Tag	
		b. Two screws (1) and washers (2)	Remove	
		c. Two electrical leads (3 and 4)	Disconnect	
		d. Setscrew (5)	Loosen	
		e. Knob (6)	Remove	Rotate counterclockwise
		f. Nut (7)	Remove	Support switch (8)
		g. Switch (8)	Remove	
		h. Nut (9)	Remove	
CLEANING				
2		All parts	Clean	Wipe with clean, dry cloth
INSPECTION				
3		a. Two electrical leads (3 and 4)	Inspect	Replace if insulation frayed or connectors damaged
		b. Knob (6) and switch (8)	Inspect	Replace if cracked or otherwise damaged
		c. All other parts	Inspect	Replace if cracked, broken, distorted, or threads damaged
INSTALLATION				
4	Instrument panel	a. Nut (9)	Install and adjust	On switch (8)
		b. Switch (8)	Position	In instrument panel opening

2-26. INSTRUMENT PANEL MAINTENANCE (CONT)

a. Switches (cont).

(7) Trailer Light Switch (cont).

STEP	LOCATION	ITEM	ACTION	REMARKS
INSTALLATION (cont)				
4 (cont)		c. Nut (7)	Install and tighten	Secures switch (8)
		d. Knob (6)	Install	Rotate clockwise
		e. Setscrew (5)	Tighten	
		f. Two electrical leads (3 and 4)	Position	
		g. Two screws (1) and washers (2)	Install and tighten	Secures leads (3 and 4)
5	Cab	Instrument panel	Lower and secure	Para 2-26g(1)
6	Battery box	Battery ground cable	Connect	Para 2-34a

2-26. INSTRUMENT PANEL MAINTENANCE (CONT)

a. Switches (cont).

(8) Blower Switch.

This task covers:

- a. Removal
- b. Cleaning

- c. Inspection
- d. Installation

INITIAL SETUP

Tools

No. 1 Common Organizational Maintenance Tool Kit
Automotive electrical tool kit

Equipment Condition

Paragraph Condition Description

Parked on level surface, engine off, and parking brake applied.
Instrument panel raised.
Battery ground cable disconnected.

Materials/Parts

Clean cloths Item 2, Appendix C
Tags Item 14, Appendix C

Personnel Required

Wheel Vehicle Mechanic, MOS 63B

KEY

- 1. Screws (3)
- 2. Washers (3)
- 3. Electrical lead (PINK)
- 4. Electrical lead (RED/WHT)
- 5. Electrical lead (RED/BLK)
- 6. Setscrew
- 7. Knob
- 8. Nut
- 9. Switch
- 10. Nut

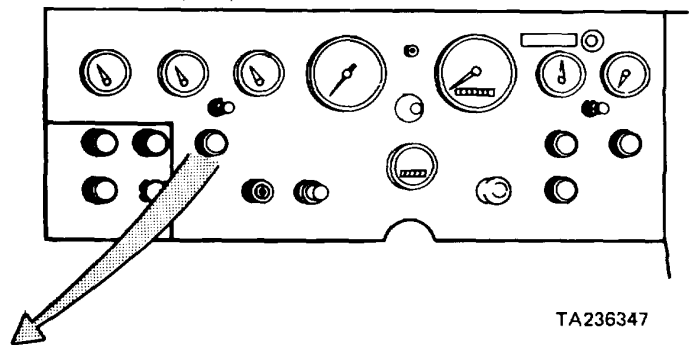
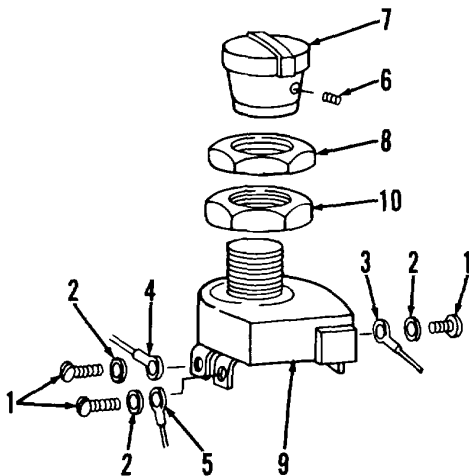

2-26. INSTRUMENT PANEL MAINTENANCE (CONT)

a. Switches (cont).

(8) Blower Switch (cont).

STEP	LOCATION	ITEM	ACTION	REMARKS
REMOVAL				
NOTE				
Tag and identify all electrical leads before disconnection and removal.				
1	Instrument panel, underside	a. Three electrical leads (3, 4, and 5)	Tag	
		b. Three screws (1) and washers (2)	Remove	
		c. Three electrical leads (3, 4, and 5)	Disconnect	
2	Instrument panel, top	a. Setscrew (6)	Loosen	
		b. Knob (7)	Remove	Rotate counterclockwise
		c. Nut (8)	Remove	Support switch (9)
		d. Switch (9) and nut (10)	Remove	
		e. Nut (10)	Separate	From switch (9)
CLEANING				
3		All parts	Clean	Wipe with clean, dry cloth
INSPECTION				
4		a. Three electrical leads (3, 4, and 5)	Inspect	Replace if insulation frayed or connectors damaged
		b. Knob (7) and switch (9)	Inspect	Replace if cracked, broken, or otherwise damaged
		c. All other parts	Inspect	Replace if cracked, broken, distorted, or threads damaged

2-26. INSTRUMENT PANEL MAINTENANCE (CONT)

a. Switches (cont).

(8) Blower Switch (cont).

STEP	LOCATION	ITEM	ACTION	REMARKS
INSTALLATION				
5	Instrument panel, top	a. Switch (9) with nut (10) b. Nut (8) c. Knob (7) d. Setscrew (6)	Position Install Install Tighten	In instrument panel. Adjust nut (10) as required Secures switch (9) Rotate clockwise
6	Instrument panel, underside	a. Three electrical leads (3, 4, and 5) b. Three washers (2) and screws (1)	Connect Install and tighten	As tagged
7	Cab	Instrument panel	Lower and secure	Para 2-26g(l)
8	Battery box	Battery ground cable	Connect	Para 2-34a

2-26. INSTRUMENT PANEL MAINTENANCE (CONT)

a. Switches (cont).

(9) 24V INVERTER Switch.

This task covers:	a. Removal	c. Inspection
	b. Cleaning	d. Installation

INITIAL SETUP

Tools

No. 1 Common Organizational Maintenance
Tool Kit
Combination wrench set

Equipment Condition

Paragraph	Condition Description
-----------	-----------------------

Materials/Parts

Clean cloths	Item 2, Appendix C	2-34a
Tags	Item 14, Appendix C	

Vehicle parked on level surface, engine off, and parking brake applied.
Battery ground cable disconnected.

Personnel Required

Wheel Vehicle Mechanic MOS 63B

KEY

1. Nut
2. Electrical lead (BRN/WHT)
3. Electrical lead (BLK)
4. Electrical lead (BLK/YEL)
5. Screws (2)
6. Washers (2)
7. Switch
8. Nut

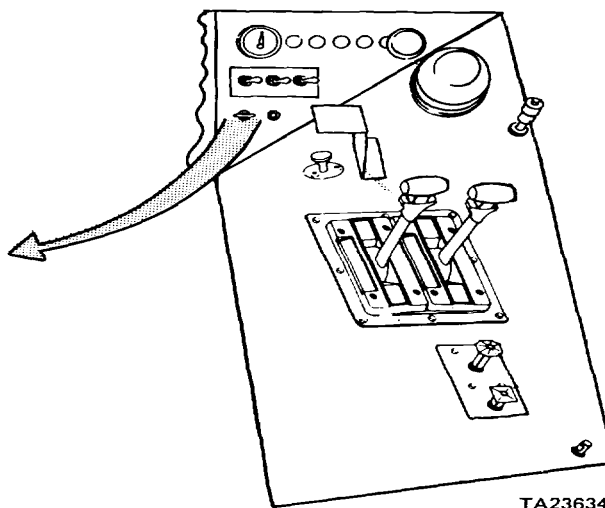
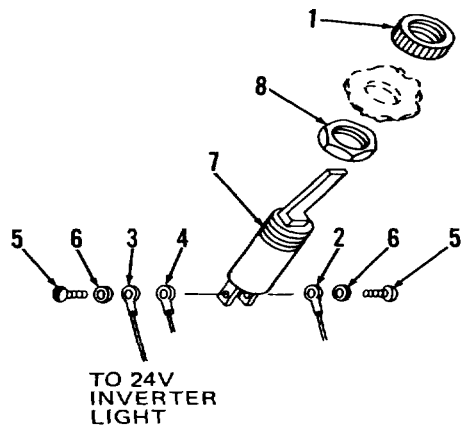

2-26. INSTRUMENT PANEL MAINTENANCE (CONT)

a. Switches (cont).

(9) 24V INVERTER Switch (cont).

STEP	LOCATION	ITEM	ACTION	REMARKS
REMOVAL				
1	Corner instrument panel, top	Nut (1)	Remove	Rotate counterclockwise
2	Cab tilt pump	Cab	Tilt cab 45 degrees	
NOTE				
Tag and identify all electrical leads before disconnecting and removing.				
3	Cab, underside	a. Three electrical leads (2 thru 4)	Tag	
		b. Two screws (5) and washers (6)	Remove	From switch (7); support switch
		c. Three electrical leads (2 thru 4)	Disconnect	
		d. Switch (7) and nut (8)	Remove and separate	
CLEANING				
4		All parts	Clean	Wipe with clean, dry cloth
INSPECTION				
5		a. Three electrical leads (2 thru 4)	Inspect	Replace if insulation frayed or connectors damaged
		b. Switch (7)	Inspect	Replace if cracked, threads damaged, or defective
		c. All other parts	Inspect	Replace if cracked, broken, or threads damaged

2-26. INSTRUMENT PANEL MAINTENANCE (CONT)

a. Switches (cont).

(9) 24V INVERTER Switch (cont).

STEP	LOCATION	ITEM	ACTION	REMARKS
INSTALLATION				
6	Cab, underside	a. Three electrical leads (2 thru 4)	Connect	Connect lead (2) to center terminal post on switch (7); connect leads (3 and 4) to remaining terminal post
		b. Two washers (6) and screws (5)	Install and tighten	
		c. Switch (7) and nut (8)	Position	Insert from underside through hole in corner instrument panel
7	Cab tilt pump	Cab	Lower	To normal operating position
8	Corner instrument panel, top	Nut (1)	Install and tighten	Rotate clockwise while an assistant located under hood holds switch (7) stationary
9	Battery box	Battery ground cable	Connect	Para 2-34a

2-26. INSTRUMENT PANEL MAINTENANCE (CONT)

a. Switches (cont).

(10) Turn Signal Flasher.

This task covers removal and installation of the turn signal flasher.

INITIAL SETUP:

Materials/Parts

Turn signal flasher FSCM 77977 PN 53102101

Equipment Condition

Paragraph

Condition Description

Parked on level surface; parking brake applied; engine off.

Personnel Required

Wheel Vehicle Mechanic MOS 63B

STEP	LOCATION	ITEM	ACTION	REMARKS
REMOVAL				
1	Instrument panel, underside	Turn signal flasher	Remove	Pull from harness connector; discard if defective
INSTALLATION				
2	Instrument panel, underside	Turn signal flasher	Install	Push contact into harness connector

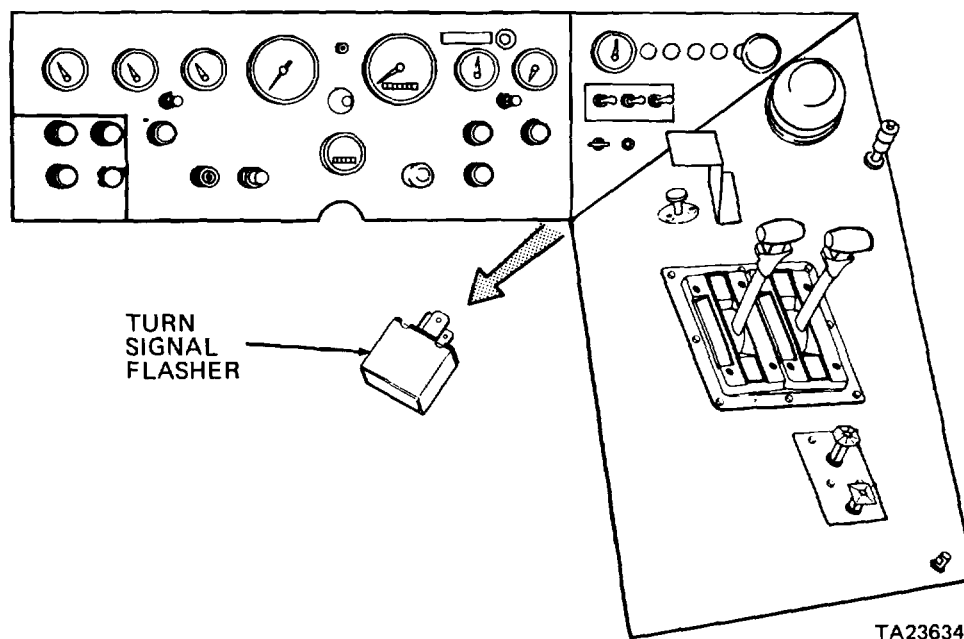

2-26. INSTRUMENT PANEL MAINTENANCE (CONT)

b. Indicator Lights.

(1) High Beam Indicator Light.

This task covers:

- a. Removal
- b. Cleaning
- c. Inspection
- d. Installation

INITIAL SETUP:

Tools

No. 1 Common Organizational Maintenance Tool Kit
 Safety glasses
 Automotive electrical tool kit

Equipment Condition

Paragraph Condition Description

Materials/Parts

Cleaning solvent Item 1, Appendix C
 Clean cloths Item 2, Appendix C

2-26g(1)
 2-34a

Vehicle parked on level surface, engine off, and parking brake applied.
 Instrument panel raised.
 Battery ground cable disconnected.

Personnel Required

Wheel Vehicle Mechanic MOS 63B

KEY

- 1. Socket
- 2. Bulb
- 3. Lens assembly
- 4. Lock washer
- 5. Housing

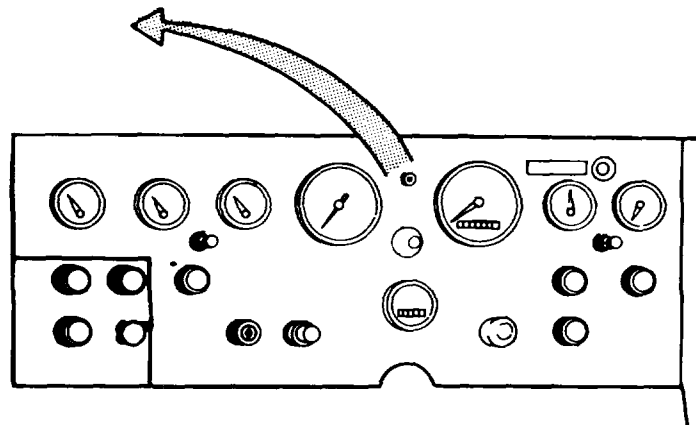
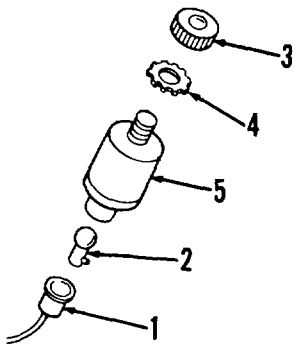

TA236213

2-26. INSTRUMENT PANEL MAINTENANCE (CONT)

b. Indicator Lights (cont).

(1) High Beam Indicator Light (cont).

STEP	LOCATION	ITEM	ACTION	REMARKS
REMOVAL				
1	Instrument panel, underside	a. Socket (1) b. Bulb (2)	Remove Remove	Grasp and pull out From socket (1)
2	Instrument panel, top	Lens assembly (3) and lock washer (4)	Remove	
3	Instrument panel, underside	Housing (5)	Remove	From instrument panel opening

CLEANING

WARNING

Dry cleaning solvent (P-D-680), used to clean parts is toxic and flammable. Wear protective goggles and gloves and use only in a well ventilated area. Avoid contact with skin, eyes, and clothes and don't breathe vapors. Do not use near open flame or excessive heat and don't smoke when using it. Failure to do so could cause serious injury. If you become dizzy while using cleaning solvent, get fresh air and medical attention immediately. If contact with skin or clothes is made, flush with large amounts of water. If contact with eyes is made, wash eyes with water and seek medical aid immediately.

Compressed air must not exceed 30 psi. Wear safety glasses when drying parts with compressed air. Failure to do so could cause serious injury to eyes and possible blindness. If you hurt your eyes or if a foreign object is blown into your eyes, seek medical attention immediately.

4		a. Lock washer (4)	Clean	Use cleaning solvent P-D-680; dry using compressed air or clean cloths
		b. All other parts	Clean	Wipe with clean, dry cloth

2-26. INSTRUMENT PANEL MAINTENANCE (CONT)

b. Indicator Lights (cont).

(1) High Beam Indicator Light (cont).

STEP	LOCATION	ITEM	ACTION	REMARKS
INSPECTION				
5		a. Socket (1)	Inspect	Replace if cracked, broken, distorted, or wire frayed
		b. Bulb (2)	Inspect	Replace if burned out or filament broken
		c. Lens assembly (3) and housing (5)	Inspect	Replace if cracked, broken, or threads damaged
INSTALLATION				
6	Instrument panel, underside	Housing (5)	Position	In instrument panel opening
7	Instrument panel, top	Lock washer (4) and lens assembly (3)	Install and tighten	
8	Instrument panel, underside	a. Bulb (2) b. Socket (1)	Install Install	In socket (1) Push in until it snaps into position
9	Cab	Instrument panel	Lower and secure	Para 2-26g(1)
10	Battery box	Battery ground cable	Connect	Para 2-34a

2-26. INSTRUMENT PANEL MAINTENANCE (CONT)

b. Indicator Lights (cont).

(2) TRANS/TORQUE CONVERTER Light.

This task covers:

- a. Removal
- b. Cleaning
- c. Inspection
- d. Installation

INITIAL SETUP:

Tools

No. 1 Common Organizational Maintenance Tool Kit
 Safety glasses
 Automotive electrical tool kit

Equipment Condition

Paragraph Condition Description

Vehicle parked on level surface, engine off, and parking brake applied.
 Instrument panel raised.
 Battery ground cable disconnected.

Materials/Parts

Cleaning solvent Item 1, Appendix C
 Clean cloths Item 2, Appendix C

2-26g(1)
 2-34a

Personnel Required

Wheel Vehicle Mechanic MOS 63B

KEY

- 1. Socket
- 2. Bulb
- 3. Nut
- 4. Lock washer
- 5. Housing
- 6. Washer

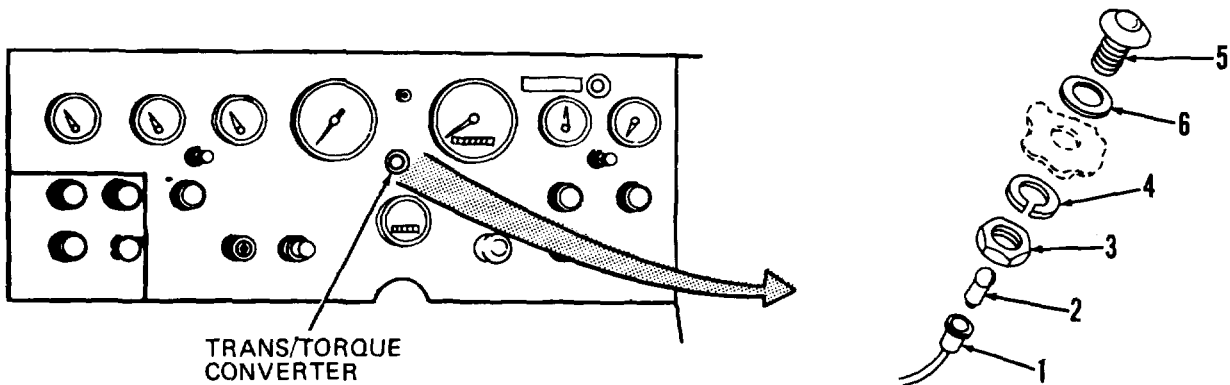

TA236214

2-26. INSTRUMENT PANEL MAINTENANCE (CONT)

b. Indicator Lights (cont).

(2) TRANS/TORQUE CONVERTER Light (cont).

STEP	LOCATION	ITEM	ACTION	REMARKS
REMOVAL				
1	Instrument panel, underside	a. Socket (1) b. Bulb (2) c. Nut (3) and lock washer (4)	Remove Remove Remove	Grasp and pull out From socket (1)
2	Instrument panel, top	Housing (5) and washer (6)	Remove and separate	Lift from instrument panel
CLEANING				
3		a. Socket (1), bulb (2), and housing (5)	Clean	Wipe with clean, dry cloth

WARNING

Dry cleaning solvent (P-D-680), used to clean parts is toxic and flammable. Wear protective goggles and gloves and use only in a well ventilated area. Avoid contact with skin, eyes, and clothes and don't breathe vapors. Do not use near open flame or excessive heat and don't smoke when using it. Failure to do so could cause serious injury. If you become dizzy while using cleaning solvent, get fresh air and medical attention immediately. If contact with skin or clothes is made, flush with large amounts of water. If contact with eyes is made, wash eyes with water and seek medical aid immediately.

Compressed air must not exceed 30 psi. Wear safety glasses when drying parts with compressed air. Failure to do so could cause serious injury to eyes and possible blindness. If you hurt your eyes or if a foreign object is blown into your eyes, seek medical attention immediately.

b. Nut (3) and washers (4 and 6)	Clean	Use cleaning solvent P-D-680; dry using compressed air
----------------------------------	-------	--

2-26. INSTRUMENT PANEL MAINTENANCE (CONT)

b. Indicator Lights (cont).

(2) TRANS/TORQUE CONVERTER Light (cont).

STEP	LOCATION	ITEM	ACTION	REMARKS
INSPECTION				
4		a. Socket (1)	Inspect	Replace if cracked, broken, distorted, or wire frayed
		b. Bulb (2)	Inspect	Replace if burned out or filament broken
		c. Housing (5)	Inspect	Replace if cracked, broken, or threads damaged
INSTALLATION				
5	Instrument panel, top	Washer (6) and housing (5)	Install	In instrument panel opening
6	Instrument panel, underside	a. Lock washer (4) and nut (3)	Install and tighten	
		b. Bulb (2)	Install	In socket (1)
		c. Socket (1)	Install	Push until it snaps into position
7	Cab	Instrument panel	Lower and secure	Para 2-26g(1)
8	Battery box	Battery ground cable	Connect	Para 2-34a

2-26. INSTRUMENT PANEL MAINTENANCE (CONT)

b. Indicator Lights (cont).

(3) LOW FUEL INDICATOR Light and Circuit Board.

This task covers:

- a. Removal
- b. Disassembly
- c. Cleaning
- d. Inspection
- e. Reassembly
- f. Installation

INITIAL SETUP:

Tools

No. 1 Common Organizational Maintenance

Tool Kit

Socket wrench set

Safety glasses

Automotive electrical tool kit

Soldering iron, electric

Personnel Required

Wheel Vehicle Mechanic MOS 63B

Equipment Condition

Paragraph

Condition Description

Materials/Parts

Cleaning solvent

Item 1, Appendix C

2-34a

Clean cloths

Item 2, Appendix C

Electrical tape

Item 37, Appendix C

2-26g(1)

Solder

Item 41, Appendix C

2-26d(1)

Vehicle parked on level surface, engine off, and parking brake applied.

Battery ground cable disconnected.

Instrument panel raised.

Fuel gage light socket and bulb removed.

STEP	LOCATION	ITEM	ACTION	REMARKS
------	----------	------	--------	---------

REMOVAL

NOTE

Tag and identify all electrical leads before disconnecting and removing.

1	Instrument panel, underside	a. Four electrical leads (3 thru 6)	Tag	
		b. Two nuts (1) and lock washers (2)	Remove	From fuel gage terminals
		c. Four electrical leads (3 thru 6)	Disconnect	From fuel gage terminals
		d. Two electrical leads (9 and 10)	Tag	
		e. Nut (7) and lock washer (8)	Remove	From fuel gage mounting stud

2-26. INSTRUMENT PANEL MAINTENANCE (CONT)

b. Indicator Lights (cont).

(3) LOW FUEL INDICATOR Light and Circuit Board (cont).

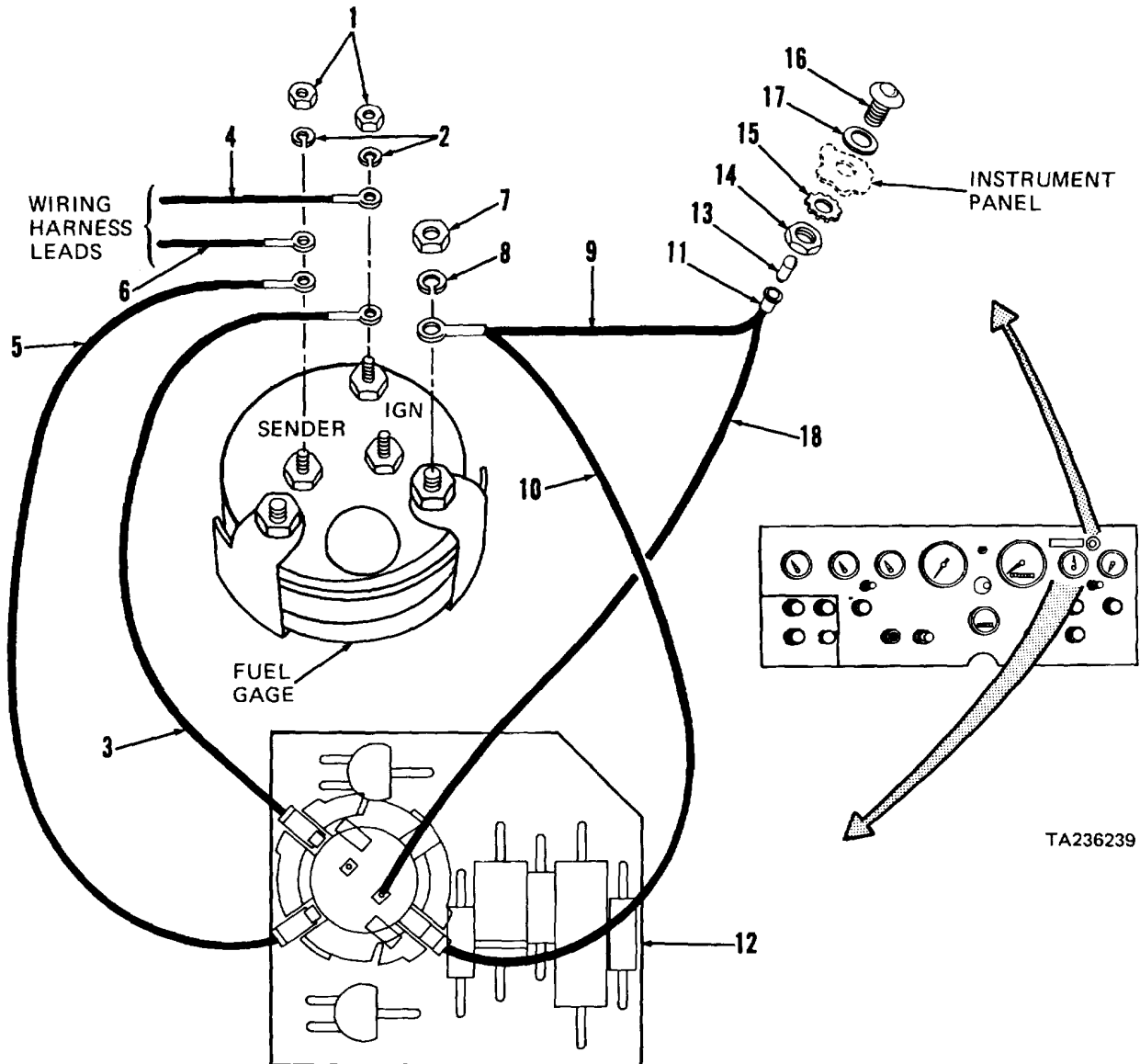

TA236239

KEY

- | | | |
|-----------------------------|---------------------------|---------------------------|
| 1. Nuts (2) | 7. Nut | 13. Bulb |
| 2. Lock washers (2) | 8. Lock washer | 14. Nut |
| 3. Electrical lead(BLK) | 9. Electrical lead (BLK) | 15. Lock washer |
| 4. Electrical lead(BLK) | 10. Electrical lead (WHT) | 16. Housing |
| 5. Electrical lead(YEL/BLK) | 11. Socket | 17. Washer |
| 6. Electrical lead(YELBLK) | 12. Circuit board | 18. Electrical lead (BLK) |

2-26. INSTRUMENT PANEL MAINTENANCE (CONT)

b. Indicator Lights (cont).

(3) LOW FUEL INDICATOR Light and Circuit Board (cont).

STEP	LOCATION	ITEM	ACTION	REMARKS
REMOVAL (cont)				
1 (cont)		f. Two electrical leads (9 and 10)	Disconnect	From fuel gage mounting stud
		g. Electrical tape	Remove	Remove tape securing circuit board (12) to instrument panel; note location for installation
		h. Circuit board (12) with socket (11) and leads	Remove	As an assembly
		i. Nut (14) and lock washer (15)	Remove	
2	Instrument panel, top	Housing (16) and washer (17)	Remove and separate	Lift from instrument panel

DISASSEMBLY

NOTE

Perform step 3 below only if necessary to replace socket (11) or circuit board (12).

3	Circuit board (12)	Two electrical leads (10 and 18)	a. Tag	Unsolder leads from circuit board terminals
			b. Remove	

CLEANING

4		a. Socket (11), circuit board (12), housing (16), and electrical leads (3 thru 6, 9, 10, and 18)	Clean	Wipe with clean, dry cloth
---	--	--	-------	----------------------------

2-26. INSTRUMENT PANEL MAINTENANCE (CONT)

b. Indicator Lights (cont).

(3) LOW FUEL INDICATOR Light and Circuit Board (cont).

STEP	LOCATION	ITEM	ACTION	REMARKS
------	----------	------	--------	---------

CLEANING (cont)

4
(cont)

WARNING

Dry cleaning solvent (P-D-680), used to clean parts is toxic and flammable. Wear protective goggles and gloves and use only in a well ventilated area. Avoid contact with skin, eyes, and clothes and don't breathe vapors. Do not use near open flame or excessive heat and don't smoke when using it. Failure to do so could cause serious injury. If you become dizzy while using cleaning solvent, get fresh air and medical attention immediately. If contact with skin or clothes is made, flush with large amounts of water. If contact with eyes is made, wash eyes with water and seek medical aid immediately.

Compressed air must not exceed 30 psi. Wear safety glasses when drying parts with compressed air. Failure to do so could cause serious injury to eyes and possible blindness. If you hurt your eyes or if a foreign object is blown into your eyes, seek medical attention immediately.

b. All other parts	Clean	Use cleaning solvent P-D-680; dry using compressed air
--------------------	-------	--

INSPECTION

5

a. Circuit board (12)	Inspect	Replace as an assembly if cracked, distorted, leads damaged, or inoperative
b. Housing (16)	Inspect	Replace if cracked, broken, or threads damaged
c. Electrical leads (3 thru 6, 9, 10, and 18)	Inspect	Replace if insulation frayed, cut, or cracked or if conductor corroded or broken
d. All other parts	Inspect	Replace if cracked, broken, or threads damaged

2-26. INSTRUMENT PANEL MAINTENANCE (CONT)

b. Indicator Lights (cont).

(3) LOW FUEL INDICATOR Light and Circuit Board (cont).

STEP	LOCATION	ITEM	ACTION	REMARKS
REASSEMBLY				
6	Circuit board (12)	Two electrical leads (10 and 18)	Connect	To circuit board terminals as tagged. Solder leads to terminals
INSTALLATION				
7	Instrument panel, top	a. Washer (17) b. Housing (16)	Position Install	On housing (16) In instrument panel opening
8	Instrument panel, underside	a. Lock washer (15) and nut (14) b. Circuit board (12) with leads c. Two electrical leads (9 and 10) d. Lock washer (8) and nut (7) e. Two electrical leads (3 and 4) f. Two electrical leads (5 and 6) g. Two lock washers (2) and nuts (1) h. Bulb (13) and socket (11)	Install a. Position b. Secure Position Install and tighten Position Position Install and tighten Install	Tighten nut (14) At instrument panel Tape circuit board to instrument panel as noted during removal On fuel gage mounting stud Secures leads (9 and 10) On fuel gage IGN terminal On fuel gage SENDER terminal Secures leads (3 thru 6) Para 2-26d(1)
9	Cab	Instrument panel	Lower and secure	Para 2-26g(1)
10	Battery box	Battery ground cable	Connect	Para 2-34a

2-26. INSTRUMENT PANEL MAINTENANCE (CONT)

b. Indicator Lights (cont).

(4) WATER LEVEL Warning Light, WATER TEMP Warning Light, OIL PRESSURE Warning Light, LOW AIR Warning Light, and 24V INVERTER Light.

This task covers:

- a. Removal
- b. Cleaning
- d. Inspection
- e. Installation

INITIAL SETUP:

Tools

No. 1 Common Organizational Maintenance Tool Kit
 Safety glasses
 Automotive electrical tool kit

Equipment Condition

Paragraph Condition Description

Materials/Parts

Cleaning solvent Item 1, Appendix C 2-34a
 Clean cloths Item 2, Appendix C

Vehicle parked on level surface, engine off, and parking brake applied. Cab tilted 45 degrees. Battery ground cable disconnected.

Personnel Required

Wheel Vehicle Mechanic MOS 63B

KEY

- 1. Socket
- 2. Bulb
- 3. Nut
- 4. Lock washer
- 5. Housing

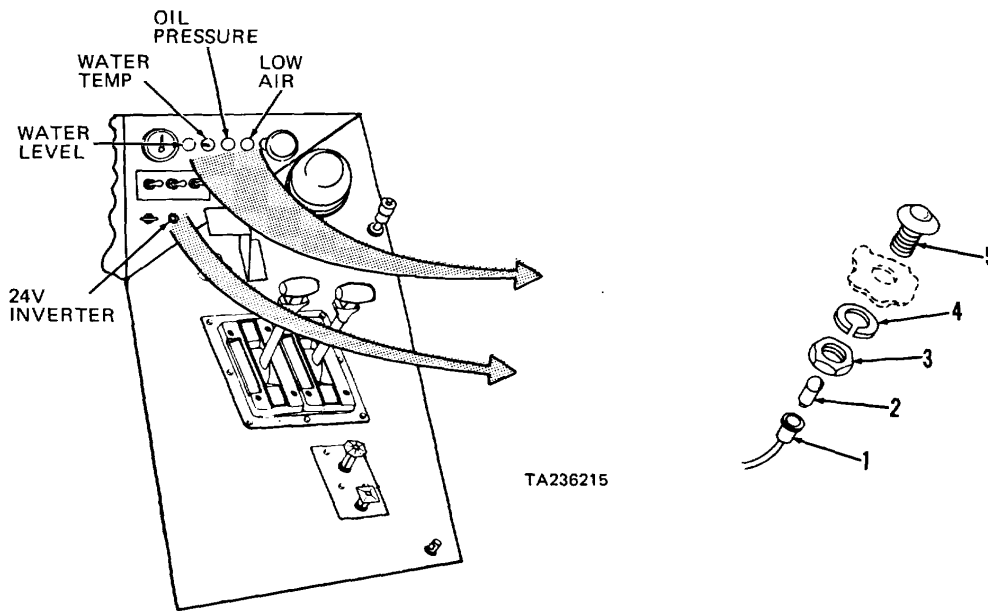

2-26. INSTRUMENT PANEL MAINTENANCE (CONT)

b. Indicator Lights (cont).

(4) WATER LEVEL Warning Light, WATER TEMP Warning Light, OIL PRESSURE Warning Light, LOW AIR Warning Light, and 24V INVERTER Light (cont).

STEP	LOCATION	ITEM	ACTION	REMARKS
REMOVAL				
1	Instrument panel, underside	a. Socket (1) b. Bulb (2) c. Nut (3) and lock washer (4)	Remove Remove Remove	Grasp and pull out From socket (1) While assistant holds housing (5)
2	Instrument panel, top	Housing (5)	Remove	Lift from instrument panel
CLEANING				
3	a.	Socket (1), bulb (2), and housing (5)	Clean	Wipe with clean, dry cloth

WARNING

Dry cleaning solvent (P-D-680), used to clean parts is toxic and flammable. Wear protective goggles and gloves and use only in a well ventilated area. Avoid contact with skin, eyes, and clothes and don't breathe vapors. Do not use near open flame or excessive heat and don't smoke when using it. Failure to do so could cause serious injury. If you become dizzy while using cleaning solvent, get fresh air and medical attention immediately. If contact with skin or clothes is made, flush with large amounts of water. If contact with eyes is made, wash eyes with water and seek medical aid immediately.

Compressed air must not exceed 30 psi. Wear safety glasses when drying parts with compressed air. Failure to do so could cause serious injury to eyes and possible blindness. If you hurt your eyes or if a foreign object is blown into your eyes, seek medical attention immediately.

b.	Nut (3) and lock washer (4)	Clean	Use cleaning solvent P-D-680; dry using compressed air
----	-----------------------------	-------	--

2-26. INSTRUMENT PANEL MAINTENANCE (CONT)

b. Indicator Lights (cont).

(4) WATER LEVEL Warning Light, WATER TEMP Warning Light, OIL PRESSURE Warning Light, LOW AIR Warning Light, and 24V INVERTER Light (cont).

STEP	LOCATION	ITEM	ACTION	REMARKS
INSPECTION				
4		a. Socket (1)	Inspect	Replace if cracked, broken, distorted, or wire frayed
		b. Bulb (2)	Inspect	Replace if burned out or filament broken
		c. Housing (5)	Inspect	Replace if cracked, broken, or threads damaged
INSTALLATION				
5	Instrument panel, top	Housing (5)	Install	In instrument panel opening
6	Instrument panel, underside	a. Lock washer (4) and nut (3)	Install and tighten	While assistant holds housing (5)
		b. Bulb (2)	Install	In socket (1)
		c. Socket (1)	Install	Push in until it snaps into position
7	Cab tilt pump	Cab Lower		To normal operating position
8	Battery box	Battery ground cable	Connect	Para 2-34a

2-26. INSTRUMENT PANEL MAINTENANCE (CONT)

c. Water Level Warning Bell and Low Air Pressure Buzzer.

(1) Water Level Warning Bell.

This task covers:

- a. Removal
- b. Cleaning
- d. Inspection
- e. Installation

INITIAL SETUP:

Tools

No. 1 Common Organizational Maintenance
Tool Kit
Screwdriver
Socket wrench set

Equipment Condition

Paragraph Condition Description

Materials/Parts

Clean cloths Item 2, Appendix C 2-34a
Tags Item 14, Appendix C

Vehicle parked on level surface, engine off, and parking brake applied. Hood raised.
Battery ground cable disconnected.

Personnel Required

Two Wheel Vehicle Mechanics MOS 63B

KEY

- 1. Locknuts (3)
- 2. Lock washers (3)
- 3. Screws (3)
- 4. Warning bell
- 5. Gasket
- 6. Screws (2)
- 7. Electrical lead (BRN/WHT)
- 8. Electrical lead (BRN/RED)

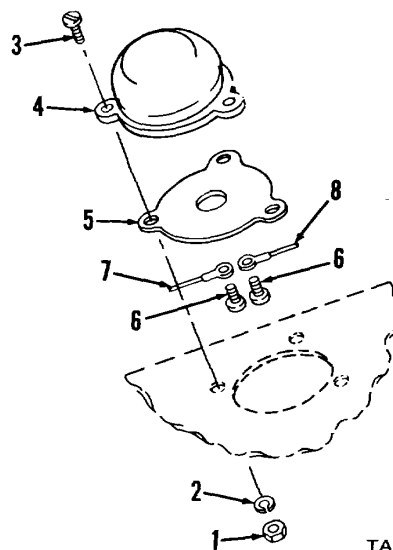
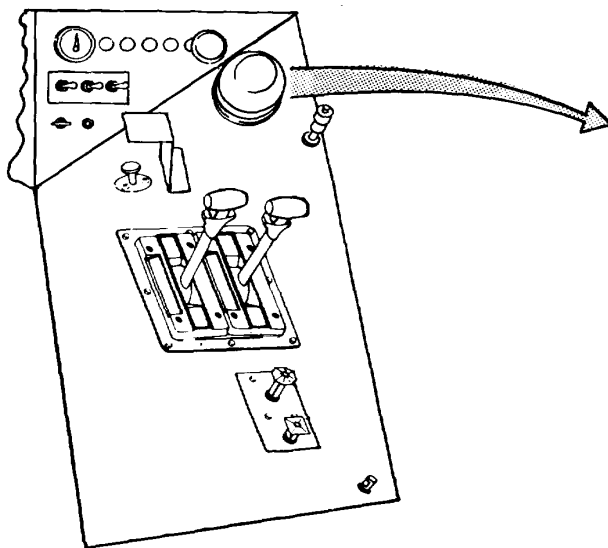

TA236342

2-26. INSTRUMENT PANEL MAINTENANCE (CONT)

c. Water Level Warning Bell and Low Air Pressure Buzzer (cont).

(1) Water Level Warning Bell (cont).

STEP	LOCATION	ITEM	ACTION	REMARKS
------	----------	------	--------	---------

REMOVAL

NOTE

Tag and identify all electrical leads before disconnecting and removing.

1	Right instrument panel	a. Two electrical leads (7 and 8)	Tag	
		b. Three locknuts (1) and lock washers (2)	Remove	While assistant above panel prevents screws (3) from rotating
		c. Three screws (3)	Remove	
		d. Warning bell (4) and gasket (5)	Remove	
		e. Two screws (6)	Remove	
		f. Two electrical leads (7 and 8)	Disconnect	

CLEANING

2		All parts	Clean	Wipe with clean, dry cloth
---	--	-----------	-------	----------------------------

INSPECTION

3	a. Two electrical leads (7 and 8)	Inspect	Replace if insulation frayed or connectors damaged
	b. Warning bell (4)	Inspect	Replace if cracked or broken
	c. All other parts	Inspect	Replace if cracked, broken, distorted, or threads damaged

2-26. INSTRUMENT PANEL MAINTENANCE (CONT)

c. Water Level Warning Bell and Low Air Pressure Buzzer (cont).

(1) Water Level Warning Bell (cont).

STEP	LOCATION	ITEM	ACTION	REMARKS
INSTALLATION				
4	Right instrument panel	a. Two electrical leads (7 and 8)	Connect	
		b. Two screws (6)	Install and tighten	
		c. Gasket (5) and warning bell (4)	Position	
		d. Three screws (3)	Install	
		e. Three lock washers (2) and locknuts (1)	Install and tighten	While assistant above panel prevents screws (3) from rotating
5	Battery box	Battery ground cable	Connect	Para 2-34a

2-26. INSTRUMENT PANEL MAINTENANCE (CONT)

c. Water Level Warning Bell and Low Air Pressure Buzzer (cont).

(2) Low Air Pressure Buzzer.

This task covers:

- a. Removal
- b. Cleaning
- d. Inspection
- e. Installation

INITIAL SETUP:

Tools

No. 1 Common Organizational Maintenance
Tool Kit
Screwdriver
Socket wrench set

Equipment Condition

Paragraph Condition Description

Materials/Parts

Clean cloths Item 2, Appendix C
Tags Item 14, Appendix C

2-34a

Parked on level surface, key switch and engine off, and parking brake applied. Cab tilted 45 degrees. Battery ground cable disconnected.

Personnel Required

Wheel Vehicle Mechanic MOS 63B

KEY

- 1. Screws (2)
- 2. Electrical lead (WHT)
- 3. Electrical lead (DK GRN/BRN)
- 4. Locknut
- 5. Buzzer

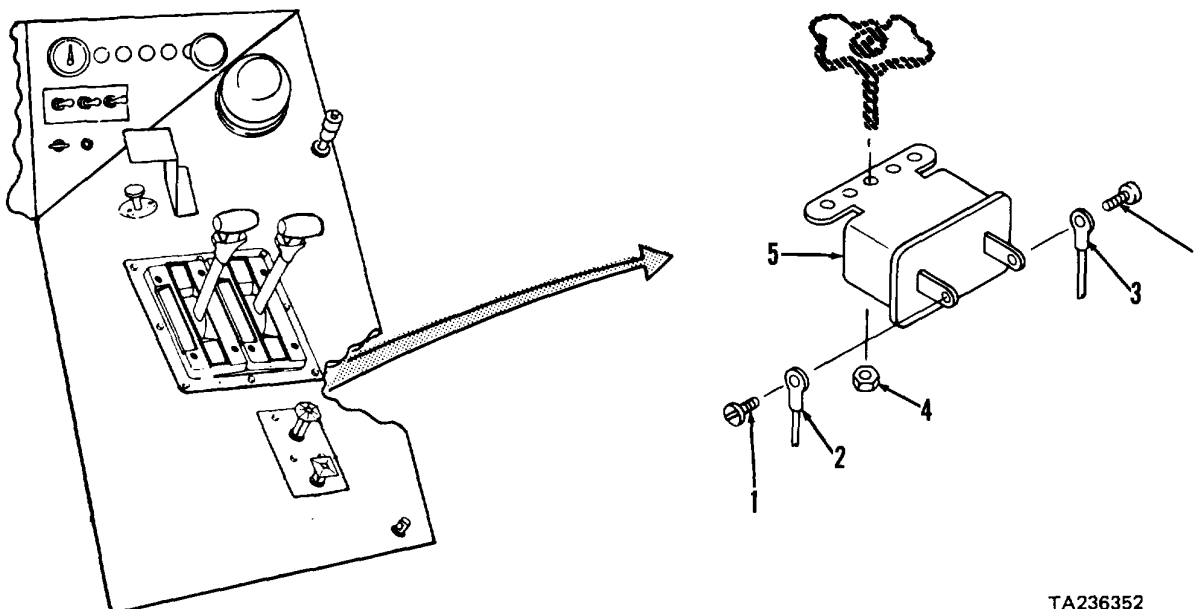

TA236352

2-26. INSTRUMENT PANEL MAINTENANCE (CONT)

- c. Water Level Warning Bell and Low Air Pressure Buzzer (cont).
- (2) Low Air Pressure Buzzer (cont).

STEP	LOCATION	ITEM	ACTION	REMARKS
REMOVAL				
NOTE				
Tag and identify all electrical leads before disconnection and removal.				
1	Instrument panel, right hand side, underside	<ul style="list-style-type: none"> a. Two electrical leads (2 and 3) b. Two screws (1) c. Two electrical leads (2 and 3) d. Locknut (4) e. Buzzer (5) 	<ul style="list-style-type: none"> Tag Remove Disconnect Remove Remove 	Support buzzer (5)
CLEANING				
2		All parts	Clean	Wipe with clean, dry cloth
INSPECTION				
3		<ul style="list-style-type: none"> a. Electrical leads (2 and 3) b. Buzzer (5) c. All other parts 	<ul style="list-style-type: none"> Inspect Inspect Inspect 	<ul style="list-style-type: none"> Replace if insulation frayed or terminals damaged Replace if cracked, broken, or inoperative Replace if cracked, broken, distorted, or threads damaged
INSTALLATION				
4	Instrument panel	<ul style="list-style-type: none"> a. Buzzer (5) b. Locknut (4) c. Two electrical leads (2 and 3) d. Two screws (1) 	<ul style="list-style-type: none"> Position Install and tighten Connect Install and tighten 	As tagged
5	Battery box	Battery ground cable	Connect	Para 2-34a

2-26. INSTRUMENT PANEL MAINTENANCE (CONT)

d. Gage Lights and Dash Lights.

(1) Gage Lights.

This task covers replacement of all instrument panel gage lights.

INITIAL SETUP:

Materials/Parts

Bulb FSCM 08108 PN 53

Personnel Required

Wheel Vehicle Mechanic MOS 63B

Equipment Condition

Paragraph Condition Description

2-26g(1) Vehicle parked on level surface, engine off and parking brake applied.
 2-65f Instrument panel raised.
 Hood open (for ammeter light replacement).
 Cab tilted 45 degrees (for ammeter light replacement).

KEY

- 1. Socket
- 2. Bulb
- 3. Gage (typical)

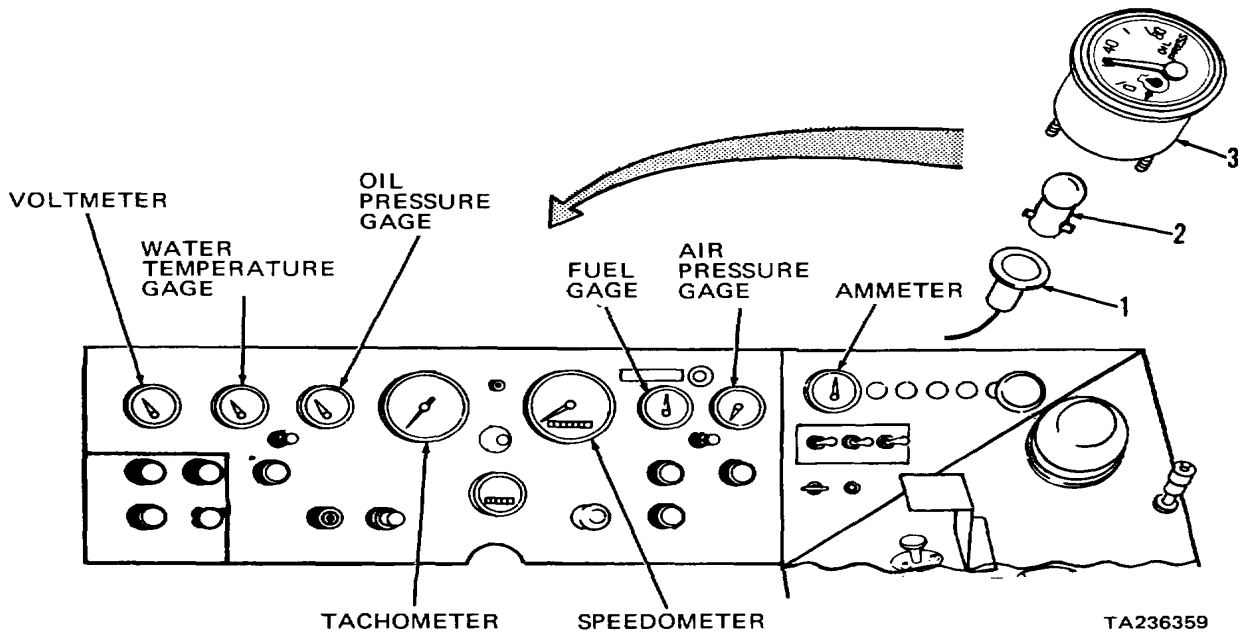

TA236359

2-26. INSTRUMENT PANEL MAINTENANCE (CONT)

d. Gage Lights and Dash Lights (cont).

(1) Gage Lights (cont).

STEP	LOCATION	ITEM	ACTION	REMARKS
REMOVAL				
1	Instrument panel, underside	a. Socket (1) b. Bulb (2)	Remove Remove and discard	Grasp and pull from gage (3) Remove from socket (1)
INSTALLATION				
2	Instrument panel, underside	a. New bulb (2) b. Socket (1)	Install Install	In socket (1) Push in until it snaps into position
3	Cab tilt pump	Cab	Lower, if necessary	To normal operating position
4	Cab, outside	Hood	Close, if necessary	Para 2-65f
5	Cab, inside	Instrument panel	Lower and secure	Para 2-26g(1)

2-26. INSTRUMENT PANEL MAINTENANCE (CONT)

d. Gage Lights and Dash Lights (cont).

(2) Dash Lights.

This task covers:

- a. Removal
- b. Cleaning
- c. Inspection
- d. Installation

INITIAL SETUP:

Tools

No. 1 Common Organizational Maintenance Tool Kit
 Safety glasses
 Automotive electrical tool kit

Personnel Required

Two Wheel Vehicle Mechanics MOS 63B

Equipment Condition

Paragraph	Condition Description
-----------	-----------------------

Materials/Parts

Cleaning solvent	Item 1, Appendix C
Clean cloths	Item 2, Appendix C
Tags	Item 14, Appendix C

2-34a

Vehicle parked on level surface, engine off, and parking brake applied. Battery ground cable disconnected.

KEY

- | | |
|------------------------------|----------------|
| 1. Hood | 5. Nut |
| 2. Bulb | 6. Lock washer |
| 3. Electrical lead (WHT) | 7. Socket |
| 4. Electrical lead (BLU/RED) | |

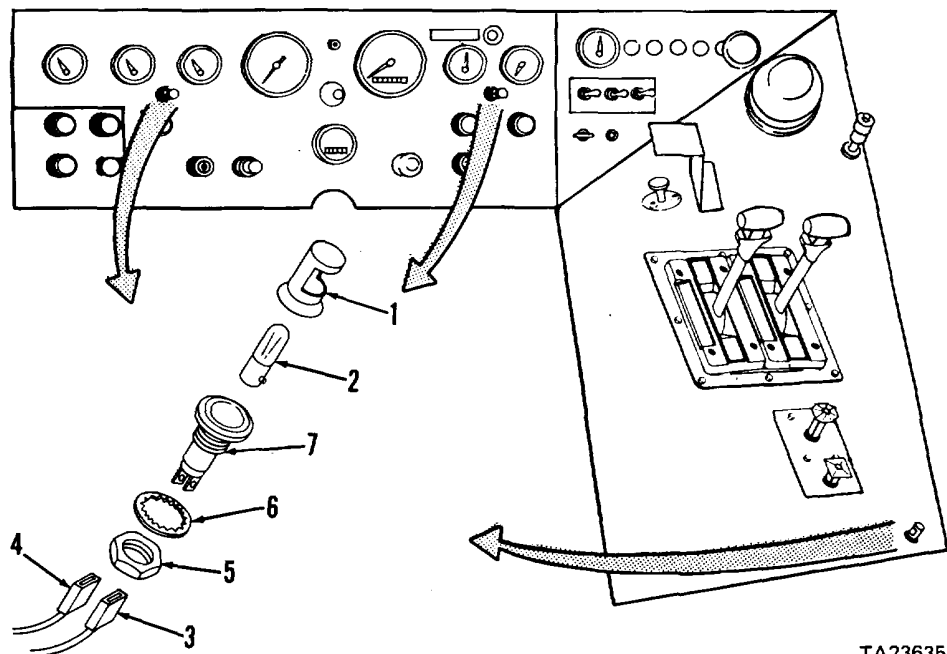

TA236350

2-26. INSTRUMENT PANEL MAINTENANCE (CONT)

d. Gage Lights and Dash Lights (cont).

(2) Dash Lights (cont).

STEP	LOCATION	ITEM	ACTION	REMARKS
------	----------	------	--------	---------

REMOVAL

1	Instrument panel, top	a. Hood (1)	Remove	Unscrew
		b. Bulb (2)	Remove	

NOTE

If right instrument panel dash light is to be removed, proceed to step 2 below. If front instrument panel dash lights are to be removed, proceed to step 3 below.

2	Cab, outside	Engine hood	Raise	Have assistant positioned under hood
---	--------------	-------------	-------	--------------------------------------

NOTE

After performing step 2 above, proceed to step 4 below.

3	Cab, inside	Instrument panel	Raise	Para 2-26g(1)
4	Instrument panel, underside	a. Two electrical leads (3 and 4)	Tag and disconnect	Unplug from socket (7)
		b. Nut (5) and lock washer (6)	Remove	
5	Instrument panel, top	Socket (7)	Remove	

2-26. INSTRUMENT PANEL MAINTENANCE (CONT)

- d. Gage Lights and Dash Lights (cont).
- (2) Dash Lights (cont).

STEP	LOCATION	ITEM	ACTION	REMARKS
------	----------	------	--------	---------

CLEANING

WARNING

Dry cleaning solvent (P-D-680), used to clean parts is toxic and flammable. Wear protective goggles and gloves and use only in a well ventilated area. Avoid contact with skin, eyes, and clothes and don't breathe vapors. Do not use near open flame or excessive heat and don't smoke when using it. Failure to do so could cause serious injury. If you become dizzy while using cleaning solvent, get fresh air and medical attention immediately. If contact with skin or clothes is made, flush with large amounts of water. If contact with eyes is made, wash eyes with water and seek medical aid immediately.

Compressed air must not exceed 30 psi. Wear safety glasses when drying parts with compressed air. Failure to do so could cause serious injury to eyes and possible blindness. If you hurt your eyes or if a foreign object is blown into your eyes, seek medical attention immediately.

6	a.	Nut (5) and lock washer (6)	Clean	Use cleaning solvent P-D-680; dry using compressed air
	b.	All other parts		Wipe with clean, dry cloth

INSPECTION

7	a.	Socket (7)	Inspect	Replace if cracked, broken, or threads damaged
	b.	Bulb (2)	Inspect	Replace if burned out or filament broken
	c.	Electrical leads (3 and 4)	Inspect	Replace if insulation frayed or terminals damaged
	d.	All other parts	Inspect	Replace if cracked, broken, or threads damaged

2-26. INSTRUMENT PANEL MAINTENANCE (CONT)

d. Gage Lights and Dash Lights (cont).

(2) Dash Lights (cont).

STEP	LOCATION	ITEM	ACTION	REMARKS
INSTALLATION				
8	Instrument panel, top	Socket (7)	Position	In instrument panel
9	Instrument panel, underside	a. Lock washer (6) and nut (5)	Install	Do not tighten
		b. Two electrical leads (3 and 4)	Connect	As tagged; plug into socket (7)
10	Instrument panel, top	a. Bulb (2)	Install	Screw on; rotate until hood opening points down (front panel lights) or points toward gear shift lever (right panel light)
		b. Hood (1)	Install and tighten	
		c. Nut (5)	Tighten	
11	Cab, outside	Engine hood	Close	If necessary
12	Cab, inside	Instrument panel	Lower and secure	Para 2-26g(1)
13	Battery box	Battery ground cable	Connect	Para 2-34a

2-26. INSTRUMENT PANEL MAINTENANCE (CONT)

e. Ammeter and 40A Circuit Breaker.

This task covers:

- a. Removal
- b. Cleaning
- c. Inspection
- d. Installation

INITIAL SETUP:

Tools

No. 1 Common Organizational Maintenance Tool Kit
 Socket wrench set
 Safety glasses

Equipment Condition
 Paragraph

Condition Description

Materials/Parts

Cleaning solvent Item 1, Appendix C 2-26d(1)
 Clean cloths Item 2, Appendix C
 Tags Item 14, Appendix C 2-34a

Vehicle parked on level surface, engine off, and parking brake applied. Cab tilted 45 degrees. Light bulb and socket removed from ammeter. Battery ground cable disconnected.

Personnel Required

Wheel Vehicle Mechanic MOS 63B

KEY

- 1. Nuts (2)
- 2. Lock washers (2)
- 3. Electrical lead (RED)
- 4. Electrical lead (BRN/ORG)
- 5. Nut
- 6. Lock washer
- 7. 40A circuit breaker
- 8. Nuts (2)
- 9. Lock washers (2)
- 10. Electrical lead (BRN/ORG)
- 11. Electrical leads (ORG)
- 12. Nuts (2)
- 13. Washers (2)
- 14. Mounting clamp
- 15. Ammeter

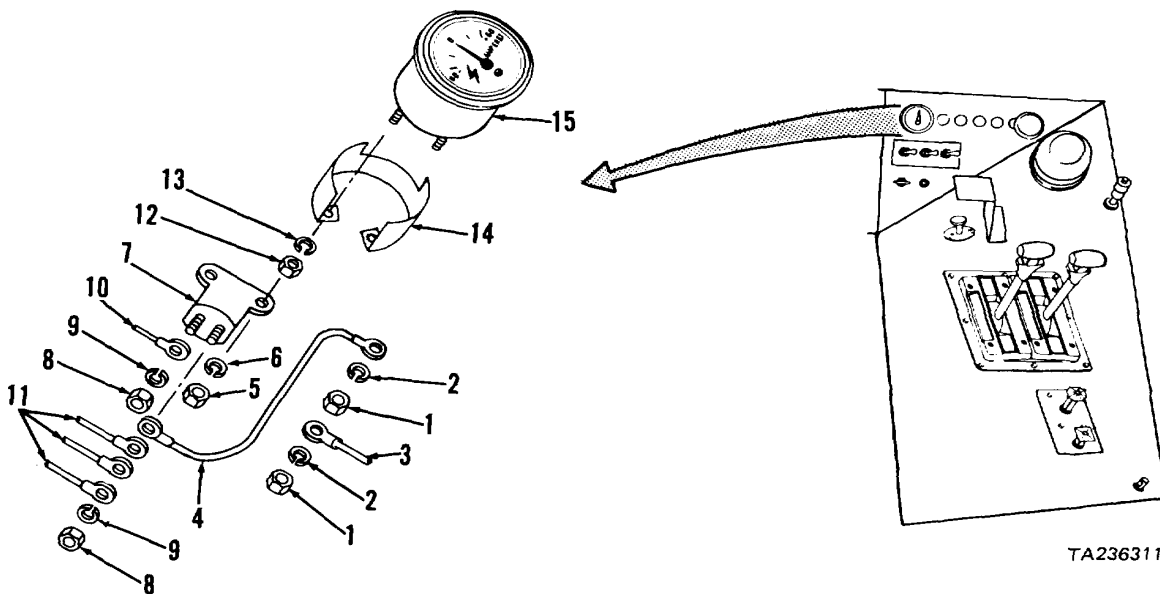

TA236311

2-26. INSTRUMENT PANEL MAINTENANCE (CONT)

e. Ammeter and 40A Circuit Breaker (cont).

STEP	LOCATION	ITEM	ACTION	REMARKS
REMOVAL				
NOTE				
Tag and identify electrical leads before disconnecting and removing.				
1	Instrument panel, underside	a. Two electrical leads (3 and 4)	Tag	
		b. Two nuts (1), lock washers (2), and electrical leads (3 and 4)	Remove	From ammeter (15) terminals
		c. Nut (5) and lock washer (6)	Remove	Support circuit breaker (7)
		d. Circuit breaker (7)	Remove	From ammeter mounting stud
		e. Two nuts (12) and washers (13)	Remove	Support mounting clamp (14)
		f. Mounting clamp (14)	Remove	From ammeter mounting studs
		g. Two nuts (8) and lock washers (9)	Remove	From circuit breaker (7) terminals
		h. Electrical leads (4, 10, and 11)	Disconnect	From circuit breaker (7) terminals
		i. Circuit breaker (7)	Remove	From tractor
2	Cab tilt pump	Cab	Lower	To normal operating position
3	Instrument panel, top	Ammeter (15)	Remove	

2-26. INSTRUMENT PANEL MAINTENANCE (CONT)

e. Ammeter and 40A Circuit Breaker (cont).

STEP	LOCATION	ITEM	ACTION	REMARKS
CLEANING				
4		a. Ammeter (15)	Clean	Wipe with clean, dry cloth

WARNING

Dry cleaning solvent (P-D-680), used to clean parts is toxic and flammable. Wear protective goggles and gloves and use only in a well ventilated area. Avoid contact with skin, eyes, and clothes and don't breathe vapors. Do not use near open flame or excessive heat and don't smoke when using it. Failure to do so could cause serious injury. If you become dizzy while using cleaning solvent, get fresh air and medical attention immediately. If contact with skin or clothes is made, flush with large amounts of water. If contact with eyes is made, wash eyes with water and seek medical aid immediately.

		b. Circuit breaker (7) and electrical leads (3, 4, 10, and 11)	Clean	Wipe with clean cloth moistened with P-D-680; dry with clean cloths
		c. All other parts	Clean	Use cleaning solvent P-D-680; dry with clean cloths

INSPECTION

5		a. Ammeter (15)	Inspect	Replace if cracked, broken, defective, or threads damaged
		b. Circuit breaker (7)	Inspect	Replace if defective, or if terminals damaged
		c. Electrical leads	Inspect	Replace if wires cracked, broken, or frayed, or terminals missing, damaged, or corroded
		d. All other parts	Inspect	Replace if cracked, broken, distorted, or threads damaged

2-26. INSTRUMENT PANEL MAINTENANCE (CONT)

e. Ammeter and 40A Circuit Breaker (cont).

STEP	LOCATION	ITEM	ACTION	REMARKS
INSTALLATION				
6	Instrument panel, top	Ammeter (15)	Install	
7	Cab tilt pump	Cab	Tilt 45 degrees	
8	Instrument panel, underside	a. Mounting clamp (14)	Position	On ammeter mounting studs
		b. Two washers (13) and nuts (12)	Install and tighten	
		c. Three electrical leads (11) and electrical lead (4)	Connect	To circuit breaker (7) battery terminal, as tagged
		d. Electrical lead (10)	Connect	To remaining circuit breaker terminal, as tagged
		e. Two lock washers (9) and nuts (8)	Install and tighten	
		f. Circuit breaker (7)	Position	On ammeter mounting stud
		g. Lock washer (6) and nut (5)	Install and tighten	
		h. Electrical lead (3)	Connect	To ammeter (15) "-" terminal, as tagged
		i. Electrical lead (4)	Connect	To ammeter (15) "+" terminal, as tagged
		j. Two lock washers (2) and nuts (1)	Install and tighten	
		k. Ammeter socket and bulb	Install	Para 2-26d(1)
9	Cab tilt pump	Cab Lower		To normal operating position
10	Battery box	Battery ground cable	Connect	Para 2-34a

2-26.INSTRUMENT PANEL MAINTENANCE (CONT)

f. Voltmeter.

This task covers:

- a. Removal
- b. Cleaning
- c. Inspection
- d. Installation

INITIAL SETUP

Tools

No. 1 Common Organizational Maintenance
Tool Kit
Socket wrench set

Equipment Condition

Paragraph Condition Description

Materials/Parts

Cleaning solvent Item 1, Appendix C
Clean cloths Item 2, Appendix C
Tags Item 14, Appendix C

2-26d(1) Vehicle parked on level surface, engine off and parking brake applied.
2-34a Light socket and bulb removed.
2-26g(1) Battery ground cable disconnected.
 Instrument panel raised.

Personnel Required

Wheel Vehicle Mechanic MOS 63B

KEY

- 1. Nuts (2)
- 2. Lock washers (2)
- 3. Electrical lead (WHT)
- 4. Electrical lead (BLK)
- 5. Nuts (2)
- 6. Lock washers (2)
- 7. Mounting clamp
- 8. Voltmeter

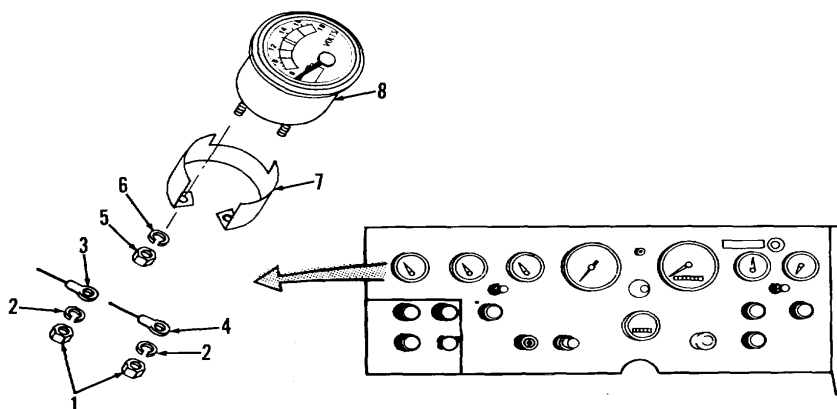

TA236310

2-26.INSTRUMENT PANEL MAINTENANCE (CONT)

f. Voltmeter (cont).

STEP	LOCATION	ITEM	ACTION	REMARKS
REMOVAL				
NOTE				
Tag and identify electrical leads before disconnection and removal.				
1	Instrument panel, underside	a. Two electrical leads (3 and 4)	Tag	
		b. Two nuts (1) and lock washers (2)	Remove	
		c. Two electrical leads (3 and 4)	Disconnect	
		d. Two nuts (5) and lock washers (6)	Remove	
		e. Mounting clamp (7)	Remove	
2	Instrument panel, top left	Voltmeter (8)	Remove	Lift from panel
CLEANING				
3		a. Two electrical leads (3 and 4)	Clean	Wipe with clean, dry cloth

WARNING

Dry cleaning solvent (P-D-680), used to clean parts is toxic and flammable. Wear protective goggles and gloves and use only in a well ventilated area. Avoid contact with skin, eyes, and clothes and don't breathe vapors. Do not use near open flame or excessive heat and don't smoke when using it. Failure to do so could cause serious injury. If you become dizzy while using cleaning solvent, get fresh air and medical attention immediately. If contact with skin or clothes is made, flush with large amounts of water. If contact with eyes is made, wash eyes with water and seek medical aid immediately.

2-26.INSTRUMENT PANEL MAINTENANCE (CONT)

f. Voltmeter (cont).

STEP	LOCATION	ITEM	ACTION	REMARKS
CLEANING (cont)				
3 (cont)		b. All other parts	Clean	Use cleaning solvent P-D-680; dry with clean cloth
INSPECTION				
4		a. Two electrical leads (3 and 4)	Inspect	Replace if cracked, broken, frayed, or wire connectors damaged
		b. Voltmeter (8) or defective	Inspect	Replace if cracked, broken,
		c. All other parts	Inspect	Replace if cracked, broken, distorted, or threads damaged
INSTALLATION				
5	Instrument panel, top	Voltmeter (8)	Install	
6	Instrument panel, underside	a. Mounting clamp (7)	Position	Slide over voltmeter mounting studs
		b. Two lock washers (6) and nuts (5)	Install and tighten	
		c. Two electrical leads (3 and 4)	Connect	White lead (3) to GRD terminal; black lead (4) to IGN terminal
		d. Two lock washers (2) and nuts (1)	Install and tighten	
		e. Socket and bulb	Install	Para 2-26d(1)
7	Instrument panel, top	Instrument panel	Lower and secure	Para 2-26g(1)
8	Battery box	Battery ground cable	Connect	Para 2-34a

2-26. INSTRUMENT PANEL MAINTENANCE (CONT)

g. Instrument Panels.

(1) Front Panel.

This task covers:

- | | |
|------------------|-------------------|
| a. Raising panel | e. Inspection |
| b. Removal | f. Reassembly |
| c. Disassembly | g. Installation |
| d. Cleaning | h. Securing panel |

INITIAL SETUP

Tools

- No. 1 Common Organizational Maintenance Tool Kit
- Screwdriver
- Safety glasses

Equipment Condition

Paragraph	Condition Description
	Parked on level surface, engine off, and parking brake applied.
2-34a	Battery ground cable disconnected.
2-85	Speedometer cable nut and housing removed from speedometer.

Materials/Parts

- Cleaning solvent Item 1, Appendix C
- Clean cloths Item 2, Appendix C

Personnel Required

Two Wheel Vehicle Mechanics MOS 63B

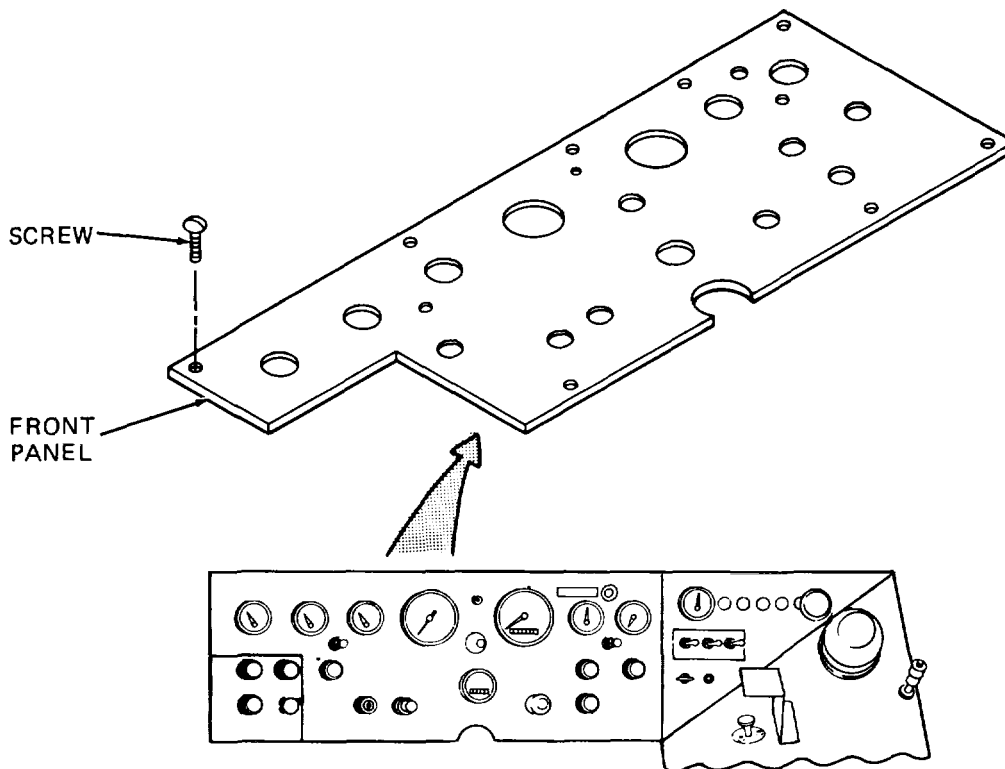

TA236367

2-26. INSTRUMENT PANEL MAINTENANCE (CONT)

g. Instrument Panels (cont).

(1) Front Panel (cont).

STEP	LOCATION	ITEM	ACTION	REMARKS
RAISING PANEL				
1	Cab, inside	a. 10 screws b. Front panel	Remove Raise	Lift front of panel up for access; then lean panel against steering column
REMOVAL				
2	Cab fire-wall, under hood	Chassis harness plug	Tag and disconnect	Para 2-35d
3	Cab, inside	a. Front instrument panel harness b. Air pressure gage air line c. Front panel with wiring harness	Tag and disconnect Disconnect Remove	Para 2-35c(1) Para 2-87b From tractor; place face down on flat work surface
DISASSEMBLY				
4	Front panel, underside	a. Voltmeter b. WATER TEMP gage c. OIL PRESS gage d. Tachometer e. TRANS/TORQUE CONVERTER light f. High beam light g. Speedometer h. FUEL gage i. LOW FUEL INDICATOR light and circuit board j. AIR PRESS gage k. Trailer light switch l. Dash lights m. WASHER switch	Remove Remove Remove Remove Remove Remove Remove Remove Remove Remove Remove Remove Remove Remove Remove Remove Remove Remove	Para 2-26f Para 2-87d Para 2-87a Para 2-86 Para 2-26b(2) Para 2-26b(1) Para 2-85 Para 2-87c Para 2-26b(3) Para 2-87b Para 2-26a(7) Para 2-26d(2) Para 2-69c

2-26. INSTRUMENT PANEL MAINTENANCE (CONT)

g. Instrument Panels (cont).

(1) Front Panel (cont).

STEP	LOCATION	ITEM	ACTION	REMARKS
DISASSEMBLY (cont)				
4 (cont)		n. Headlight switch	Remove	Para 2-26a(4)
		o. Quick start switch	Remove	Para 2-26a(2)
		p. Hourmeter	Remove	Para 2-88
		q. Engine stop switch	Remove	Para 2-26a(3)
		r. Ignition switch	Remove	Para 2-26a(1)
		s. Blower switch	Remove	Para 2-26a(8)
		t. Windshield wiper switch	Remove	Para 2-69b(1)

CLEANING

WARNING

Dry cleaning solvent (P-D-680), used to clean parts is toxic and flammable. Wear protective goggles and gloves and use only in a well ventilated area. Avoid contact with skin, eyes, and clothes and don't breathe vapors. Do not use near open flame or excessive heat and don't smoke when using it. Failure to do so could cause serious injury. If you become dizzy while using cleaning solvent, get fresh air and medical attention immediately. If contact with skin or clothes is made, flush with large amounts of water. If contact with eyes is made, wash eyes with water and seek medical aid immediately.

5		Screws and front panel	Clean	Use cleaning solvent P-D-680;
---	--	------------------------	-------	-------------------------------

INSPECTION

6		a. Front panel	Inspect	Replace if cracked
		b. Screws	Inspect	Replace if cracked or threads damaged

REASSEMBLY

7	Front panel, underside	a. Voltmeter	Install	Para 2-26f
		b. WATER TEMP gage	Install	Pars 2-87d
		c. OIL PRESS gage	Install	Pars 2-87a
		d. Tachometer	Install	Pars 2-86

2-26. INSTRUMENT PANEL MAINTENANCE (CONT)

g. Instrument Panels (cont).

(1) Front Panel (cont).

STEP	LOCATION	ITEM	ACTION	REMARKS
REASSEMBLY (cont)				
7 (cont)		e. TRANS/TORQUE CONVERTER light	Install	Para 2-26b(2)
		f. High beam light	Install	Para 2-26b(1)
		g. Speedometer	Install	Para 2-85
		h. FUEL gage	Install	Para 2-87c
		i. LOW FUEL INDICATOR light and circuit board	Install	Para 2-26b(3)
		j. AIR PRESS gage	Install	Para 2-87b
		k. Trailer light switch	Install	Para 2-26a(7)
		l. Dash lights	Install	Para 2-26d(2)
		m. WASHER switch	Install	Para 2-69c
		n. Headlight switch	Install	Para 2-26a(4)
		o. Quick start switch	Install	Para 2-26a(2)
		p. Hourmeter	Install	Para 2-88
		q. Engine stop switch	Install	Para 2-26a(3)
		r. Ignition switch	Install	Para 2-26a(1)
		s. Blower switch	Install	Para 2-26a(8)
		t. Windshield wiper switch	Install	Para 2-69b(1)

NOTE

Install decals on front panel as necessary (see para2-74).

INSTALLATION

8	Cab, inside	a. Front panel with wiring harness	Position	Place in raised position; against steering column
		b. Air pressure gage air line	Connect	Para 2-87b
		c. Front instrument panel harness	Connect	As tagged; para 2-35c(1)

2-26. INSTRUMENT PANEL MAINTENANCE (CONT)

g. Instrument Panels (cont).

(1) Front Panel (cont).

STEP	LOCATION	ITEM	ACTION	REMARKS
INSTALLATION (cont)				
9	Cab fire-wall, under hood	Chassis harness plug	Connect and tighten capscrew	As tagged; para 2-35d
SECURING PANEL				
10	Cab, inside	a. Front panel b. 10 screws c. Speedometer cable nut and housing	Lower Install and tighten Install	Para 2-85
11	Battery box	Battery ground cable	Connect	Para 2-34a

2-26. INSTRUMENT PANEL MAINTENANCE (CONT)

g. Instrument Panels (cont).

(2) Right Corner Panel.

This task covers replacement of the right corner instrument panel.

INITIAL SETUP

Tools

No. 1 Common Organizational Maintenance
Tool Kit
Screwdriver
Safety glasses

Materials/Parts

Cleaning solvent Item 1, Appendix C
Clean cloths Item 2, Appendix C

Personnel Required

Wheel Vehicle Mechanic MOS 63B

Equipment Condition

Paragraph	Condition Description
	Parked on level surface, engine off, and parking brake applied.
2-65h	Front grille removed.
2-34a	Battery ground cable disconnected.
2-26e	Ammeter removed.
2-26b(4)	Warning lights and 24V INVERTER light removed.
2-26a(6)	Flood light switches removed.
2-26a(9)	24V INVERTER switch removed.
3-42b	PTO cable disconnected and PTO control knob removed.

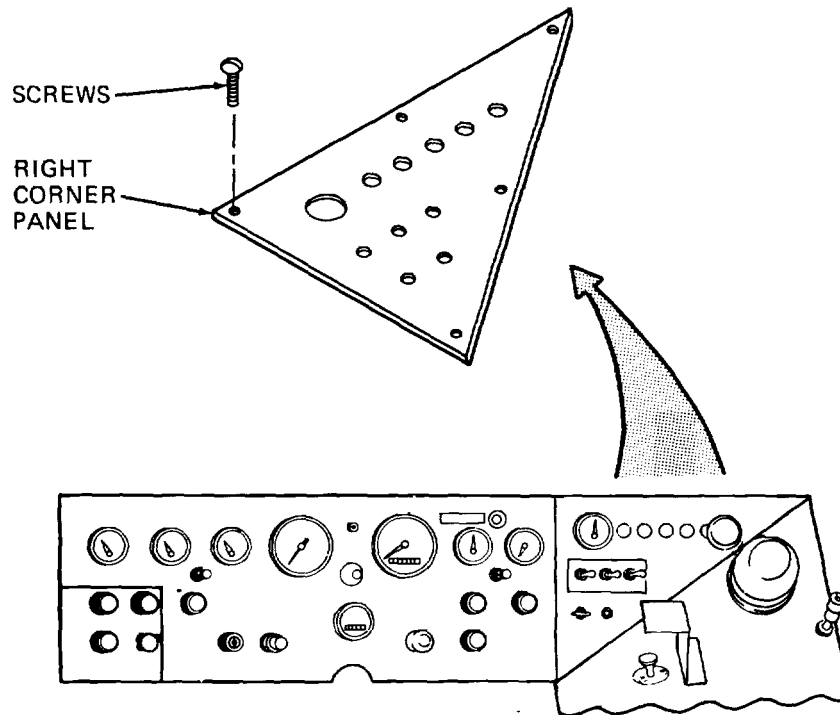

TA236368

2-26. INSTRUMENT PANEL MAINTENANCE (CONT)J

g. Instrument Panels (cont).

(2) Right Corner Panel (cont).

STEP	LOCATION	ITEM	ACTION	REMARKS
REMOVAL				
1	Cab, inside	a. Five screws b. Right corner panel	Remove Remove	Lift from cab
CLEANING				
<u>WARNING</u>				
Dry cleaning solvent (P-D-680), used to clean parts is toxic and flammable. Wear protective goggles and gloves and use only in a well ventilated area. Avoid contact with skin, eyes, and clothes and don't breathe vapors. Do not use near open flame or excessive heat and don't smoke when using it. Failure to do so could cause serious injury. If you become dizzy while using cleaning solvent, get fresh air and medical attention immediately. If contact with skin or clothes is made, flush with large amounts of water. If contact with eyes is made, wash eyes with water and seek medical aid immediately.				
2		Screws and right corner panel	Clean	Use cleaning solvent P-D-680; dry with clean cloths
INSPECTION				
3		a. Right corner panel b. Screws	Inspect Inspect	Replace if cracked Replace if cracked or threads damaged
INSTALLATION				
4	Cab, inside	a. Right corner panel b. Five screws	Position Install and tighten	Align mounting holes

2-26. INSTRUMENT PANEL MAINTENANCE (CONT)

g. Instrument Panels (cont).

(2) Right Corner Panel (cont).

STEP	LOCATION	ITEM	ACTION	REMARKS
INSTALLATION (cont)				
5	Right corner panel, underside	a. PTO control knob and cable	Install	Para 3-42b
		b. 24V INVERTER switch	Install	Para 2-26a(9)
		c. Flood light switches	Install	Para 2-26a(6)
		d. Warning lights and 24V INVERTER light	Install	Para 2-26b(4)
		e. Ammeter	Install	Para 2-26e
6	Cab front	Front grille	Install	Para 2-65h
7	Battery box	Battery ground cable	Connect	Para 2-34a

NOTE

Install decals on right corner panel as necessary (see para 2-74).

2-26. INSTRUMENT PANEL MAINTENANCE (CONT)

g. Instrument Panels (cont).

(3) Right Panel. This task covers replacement of the right instrument panel.

INITIAL SETUP

Tools

No. 1 Common Organizational Maintenance
 Tool Kit
 Screwdriver
 Safety glasses

Equipment Condition

Paragraph Condition Description

Materials/Parts

Cleaning solvent Item 1, Appendix C
 Clean cloths Item 2, Appendix C

2-34a	Battery ground cable disconnected.
2-41h(l)	All air pressure relieved.
2-26d(2)	Dash light removed.
2-41g(2)	Fifth wheel and gear shift control mounting plate removed.
3-33b	Fifth wheel unlatch valve removed.
3-24a	Brake air control valve removed.
3-12d	Right instrument panel wiring harness removed.

Personnel Required

Wheel Vehicle Mechanic MOS 63B

2-26. INSTRUMENT PANEL MAINTENANCE (CONT)

g. Instrument Panels (cont).

(3) Right Panel (cont).

STEP	LOCATION	ITEM	ACTION	REMARKS
REMOVAL				
1	Cab, inside	a. 10 screws b. Right panel	Remove Remove	Lift from cab

CLEANING

WARNING

Dry cleaning solvent (P-D-680), used to clean parts is toxic and flammable. Wear protective goggles and gloves and use only in a well ventilated area. Avoid contact with skin, eyes, and clothes and don't breathe vapors. Do not use near open flame or excessive heat and don't smoke when using it. Failure to do so could cause serious injury. If you become dizzy while using cleaning solvent, get fresh air and medical attention immediately. If contact with skin or clothes is made, flush with large amounts of water. If contact with eyes is made, wash eyes with water and seek medical aid immediately.

2		Screws and right panel	Clean	Use cleaning solvent P-D-680; dry with clean cloths
---	--	------------------------	-------	---

INSPECTION

3		a. Right panel b. Screws	Inspect Inspect	Replace if cracked Replace if cracked or threads damaged
---	--	-----------------------------	--------------------	---

INSTALLATION

4	Cab, inside	a. Right panel b. 10 screws c. Fifth wheel and gear shift control mounting plate	Position Install and tighten Install	Align mounting holes Para 2-41g(2)
---	----------------	--	--	---

2-285

TM 9-2320-285-24-1

2-26. INSTRUMENT PANEL MAINTENANCE (CONT)

g. Instrument Panels (cont).

(3) Right Panel (cont).

STEP	LOCATION	ITEM	ACTION	REMARKS
INSTALLATION (cont)				
5	Cab, under hood	a. Right instrument panel wiring	Install	Para 3-12d

		harness		
		b. Gear shift control lever and cable	Install	Para 2-41g(l)
		c. Fifth wheel control lever and cable	Install	Para 2-78a
		d. Fifth wheel unlatch valve	Install	Para 3-33b
		e. Brake air control valve	Install	Para 3-24a
		f. Dash light	Install	Para 2-26d(2)
6	Right panel, top	Unlatch control caution decal	Install, if necessary	Para 2-74
7	Battery box	Battery ground cable	Connect	Para 2-34a
8	Tractor	Air pressure	Restore	Para 2-41h(l)

2-27. TURN SIGNAL CONTROL MAINTENANCE

This task covers:

- a. Removal
- b. Cleaning
- c. Inspection
- d. Installation

INITIAL SETUP

Tools

No. 1 Common Organizational Maintenance
 Tool Kit
 Needle nose pliers
 Screwdriver set
 Safety glasses

Personnel Required

Wheel Vehicle Mechanic MOS 63B

Equipment Condition

Paragraph Condition Description

Vehicle parked on level surface, engine off, and parking brake applied.

2-58a Steering wheel removed.

2-33b Horn button electrical contact removed.

Materials/Parts

Cleaning solvent Item 1, Appendix C
 Clean cloths Item 2, Appendix C
 Tags Item 14, Appendix C
 Denatured alcohol Item 30, Appendix C

STEP	LOCATION	ITEM	ACTION	REMARKS
------	----------	------	--------	---------

REMOVAL

1	Steering column	a. Turn signal lever (1)	Remove	Rotate counterclockwise
		b. Indicator cover (2)	Remove	Rotate counterclockwise
		c. Bulb (3)	Remove	From socket (14)
		d. Two screws (4)	Remove	From light housing (5)
		e. Light housing (5) and O-ring (6)	Remove	
		f. Two screws (7)	Remove	From hazard warning switch (12)

NOTE

Tag and identify electrical leads (15) before removing connector pins (8) from connector housing (9).

g. Eight connector pins (8)	Disconnect	Squeeze with needle nose pliers and push from connector housing (9)
h. Two screws (10)	Remove	From turn signal switch (11)

2-27. TURN SIGNAL CONTROL MAINTENANCE (CONT)

KEY

- | | |
|-----------------------|---------------------------|
| 1. Turn signal lever | 9. Connector housing |
| 2. Indicator cover | 10. Screws (2) |
| 3. Bulb | 11. Turn Signal switch |
| 4. Screws (2) | 12. Hazard warning switch |
| 5. Light housing | 13. Horn contact |
| 6. O-ring | 14. Socket |
| 7. Screws (2) | 15. Electrical leads (8) |
| 8. Connector pins (8) | |

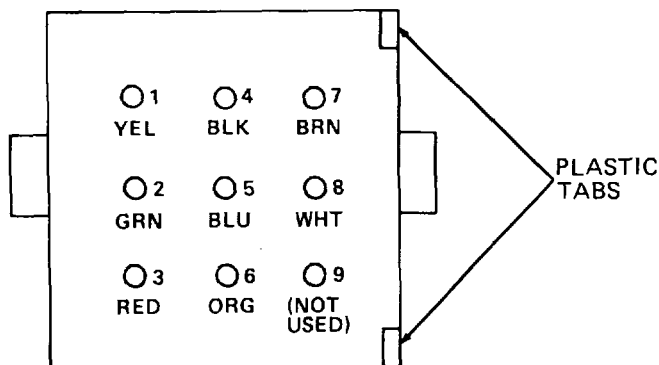
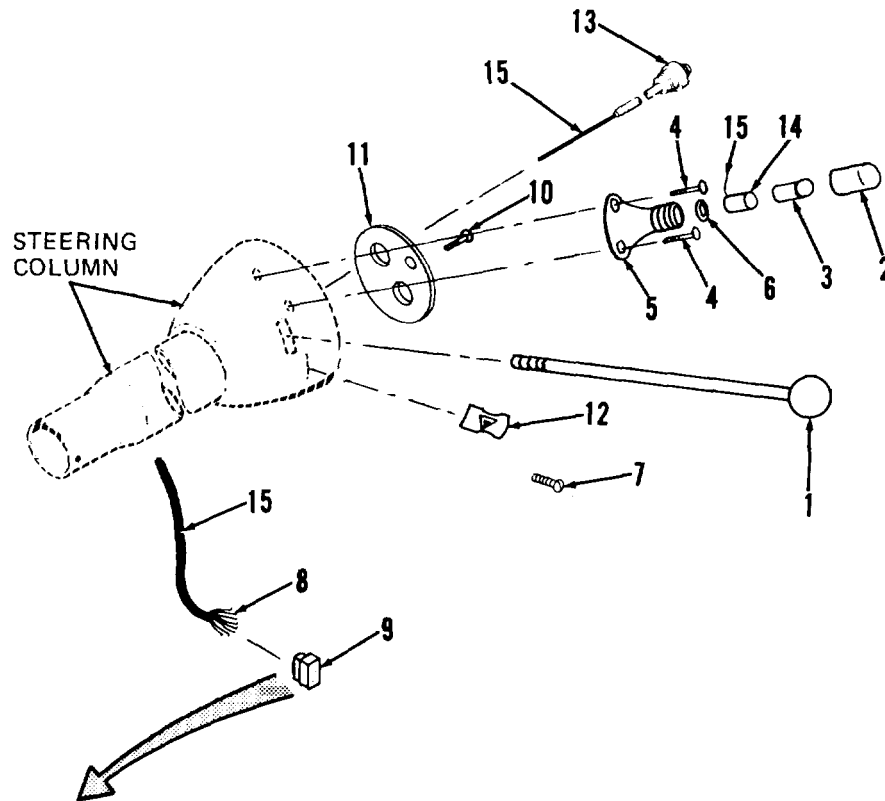

TA236353

2-27. TURN SIGNAL CONTROL MAINTENANCE (CONT)

STEP	LOCATION	ITEM	ACTION	REMARKS
REMOVAL (cont)				
1 (cont)		i. Turn signal switch (11), hazard warning switch (12), horn contact (13), socket (14), and eight electrical leads (15)	Remove	As an assembly. Carefully pull assembly up and out of steering column
CLEANING				
2		a. Switch assembly (11 thru 15)	Clean	Wipe with clean, dry, lint-free cloth
		b. Horn contact (13)	Clean	Wipe with clean cloth moistened with denatured alcohol

WARNING

Dry cleaning solvent (P-D-680), used to clean parts is toxic and flammable. Wear protective goggles and gloves and use only in a well ventilated area. Avoid contact with skin, eyes, and clothes and don't breathe vapors. Do not use near open flame or excessive heat and don't smoke when using it. Failure to do so could cause serious injury. If you become dizzy while using cleaning solvent, get fresh air and medical attention immediately. If contact with skin or clothes is made, flush with large amounts of water. If contact with eyes is made, wash eyes with water and seek medical aid immediately.

Compressed air must not exceed 30 psi. Wear safety glasses when drying parts with compressed air. Failure to do so could cause serious injury to eyes and possible blindness. If you hurt your eyes or if a foreign object is blown into your eyes, seek medical attention immediately.

c. All other metal parts	Clean	Use cleaning solvent P-D-680; dry with compressed air
--------------------------	-------	---

2-27. TURN SIGNAL CONTROL MAINTENANCE (CONT)

STEP	LOCATION	ITEM	ACTION	REMARKS
INSPECTION				
3		a. Electrical leads (15), connector pins (8), and connector housing (9)	Inspect	Replace if cracked, broken, connector pins broken or missing, or otherwise damaged
		b. All other parts	Inspect	Replace if cracked, broken, distorted, or threads damaged
INSTALLATION				
4	Steering column	a. Turn signal switch (11), hazard warning switch (12), horn contact (13), socket (14), and eight electrical leads (15)	Install	As an assembly
		b. Two screws (10)	Install	Secures turn signal switch (11)
		c. Two screws (7)	Install	Secures hazard warning switch (12)
		d. O-ring (6) and light housing (5)	Position	
		e. Two screws (4)	Install	Secures light housing (5)
		f. Bulb (3)	Install	In socket (14)
		g. Indicator cover (2)	Install	Rotate clockwise
		h. Turn signal lever (1)	Install	Rotate clockwise
		i. Eight connector pins (8)	Install	In connector housing (9), as tagged
		j. Horn button electrical contact	Install	Para 2-33b
		k. Steering wheel	Install	Para 2-58a
5	Tractor	a. Turn signals	Test operation	
		b. Hazard warning signal	Test operation	

2-28. ENGINE WARNING KIT MAINTENANCE

This task covers:

- a. Testing
- b. Removal
- c. Cleaning
- d. Repair
- e. Inspection
- f. Installation

INITIAL SETUP

Tools

No. 1 Common Organizational Maintenance Tool Kit

- Socket wrench set
- Screwdriver
- Fine tooth hacksaw
- Scratch wire brush
- Safety glasses

Automotive Mechanic's Tool Kit

Combination wrench set Paragraph

Mandrel assembly tool

FSCM 00624 PN 1582-8

Hydraulic oil Item 22, Appendix C
 Thread sealant Item 29, Appendix C
 Jumper wire

Personnel Required

Two Wheel Vehicle Mechanics MOS 63B

Equipment Condition

Condition Description

Vehicle parked on level surface, engine off, and parking brake applied. Right corner instrument panel raised (for testing).

Materials/Parts

Cleaning solvent Item 1, Appendix C
 Clean cloths Item 2, Appendix C

2-26g(2)

STEP	LOCATION	ITEM	ACTION	REMARKS
------	----------	------	--------	---------

ON-VEHICLE TESTING

NOTE

For the following tests, engine should be below normal operating temperature (less than 180 degrees), and air tanks should be charged to at least 80 psi.

1	Tractor cab	Key switch	Place in ON position	Alarm bell should sound, and OIL PRESSURE and WATER LEVEL warning lights should be on. If bell or lights do not operate, check all wires and connections. If wires and connections are okay, check bell (para 2-26c(1)) and warning light bulbs (para 2-26b(4)). If alarm bell and bulbs are okay, replace pressure sender (step 7 below) and water level sensor (para 2-29). If WATER TEMP light is also on, check diodes (para 2-35f)
---	-------------	------------	----------------------	---

2-28. ENGINE WARNING KIT MAINTENANCE (CONT)

KEY

- 1. Alarmstat sensor
- 2. Oil pressure warning sender
- 3. Oil pressure sender
- 4. Elbow
- 5. Fitting
- 6. Fitting
- 7. Hose

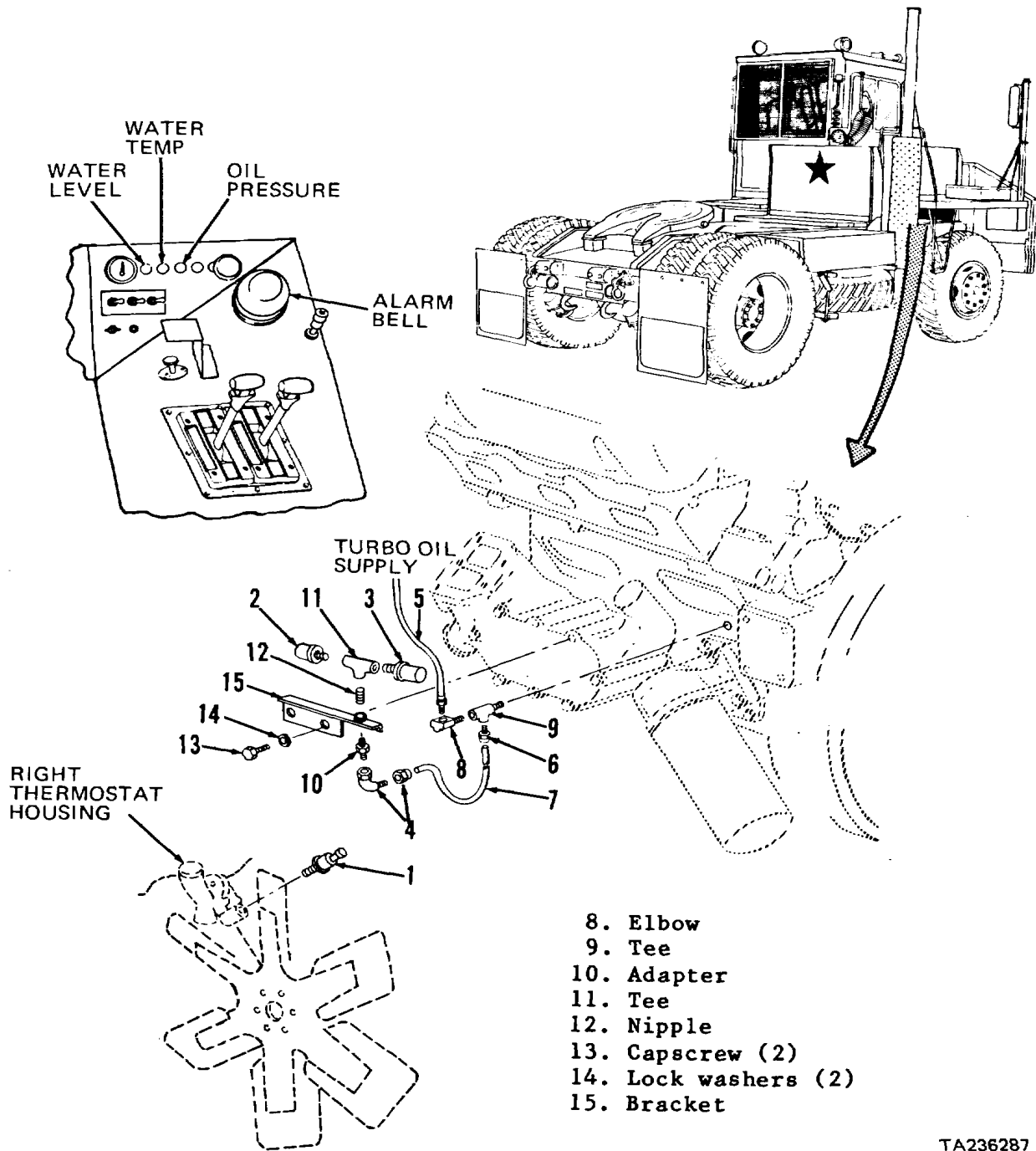

2-28. ENGINE WARNING KIT MAINTENANCE (CONT)

STEP	LOCATION	ITEM	ACTION	REMARKS
ON-VEHICLE TESTING (cont)				
2	Engine, front, right side	Jumper wire	Connect	Between alarmstat sensor (1) lead and ground
3	Tractor cab	a. Key switch	Place in ON position	Start engine. Alarm bell should sound and WATER TEMP warning light should be lit. If alarm bell and light do not operate, check all wires and connections. If wires and connections are okay, replace alarmstat sensor (step 6 below). If OIL PRESSURE warning light and/or WATER LEVEL warning lights are lit, check diodes (para 2-35f). Turn engine off and disconnect jumper wire Para 2-26g(2)
		b. Right corner instrument panel	Lower and secure	
REMOVAL				
4	Cab tilt pump	Cab	Tilt 45 degrees	
5	Engine compartment	Radiator and engine	Drain coolant	Para 2-15a(1)
6	Right thermostat housing	Alarmstat sensor (1)	Remove	Para 2-32c
7	Engine, left side	a. Oil pressure warning sender (2)	Remove	Para 2-32a
		b. Oil pressure sender (3)	Remove	Para 2-32a
		c. Elbow (4)	Loosen and disconnect	From adapter (10)
		d. Fitting (5)	Loosen and disconnect	From elbow (8)
		e. Fitting (6)	Loosen and disconnect	From tee (9)

2-28. ENGINE WARNING KIT MAINTENANCE (CONT)
--

STEP	LOCATION	ITEM	ACTION	REMARKS
REMOVAL (cont)				
7 (cont)		f. Hose (7)	Remove	
		g. Elbow (8)	Remove	
		h. Tee (9)	Remove	
		i. Adapter (10)	Remove	
		j. Tee (11)	Remove	
		k. Nipple (12)	Remove	
8	Engine, front bottom left	a. Lower radiator hose	Disconnect	Para 2-15c
		b. Radiator make- up line and heater pump	Disconnect	Para 2-73e
		c. Water pump	Remove	Refer to TM 9-2815-205-34
		d. Oil cooler	Remove	Refer to TM 9-2815-205-34
9	Oil cooler	a. Two capscrews (13) and lock washers (14)	Remove	
		b. Bracket (15)	Remove	
CLEANING				
10		a. Alarmstat sensor (1), oil pressure warning send- er (2), and oil pressure sender (3)	Clean	Wipe with clean dry cloth
		b. Hose (7)	Clean	Use mild detergent and clean cloth

WARNING

Dry cleaning solvent (P-D-680), used to clean parts is toxic and flammable. Wear protective goggles and gloves and use only in a well ventilated area. Avoid contact with skin, eyes, and clothes and don't breathe vapors. Do not use near open flame or excessive heat and don't smoke when using it. Failure to do so could cause serious injury. If you become dizzy while using cleaning solvent, get fresh air and medical attention immediately. If contact with skin or clothes is made, flush with large amounts of water. If contact with eyes is made, wash eyes with water and seek medical aid immediately.

2-28. ENGINE WARNING KIT MAINTENANCE (CONT)

STEP	LOCATION	ITEM	ACTION	REMARKS
CLEANING (cont)				
10 (cont)		c. Remaining parts	Clean	Use cleaning solvent P-D-680; dry using clean cloths
INSPECTION				
11		a. Alarmstat sensor (1), oil pressure warning sender (2), and oil pressure sender (3)	Inspect for cracks corrosion breaks loose terminals damaged threads	Replace if defects observed
		b. Hose (7)	Inspect for cracks breaks cuts deterioration	Replace if defects observed; refer to step 12 below for repair procedure
		c. Fitting (6) and elbow (4)	Inspect for cracks breaks damaged threads	Replace if defects observed; refer to step 12 below for repair procedure
		d. Remaining parts	Inspect for cracks breaks deformation damaged threads	Replace if defects observed
REPAIR				

CAUTION

If fitting (6) and/or elbow (4) require replacement, discard hose (7). If hose is reused, oil leakage could occur causing damage to engine.

12	Hose (7)	a. Fitting (6) b. Fitting nipple c. Hose (7)	Place fitting socket in vise as shown Use open end wrench and unscrew nipple counterclockwise out of fitting socket Turn hose (7) clockwise out of fitting socket
----	----------	--	---

2-28. ENGINE WARNING KIT MAINTENANCE (CONT)

STEP	LOCATION	ITEM	ACTION	REMARKS
REPAIR (cont)				
12 (cont)		d. Elbow (4)		Place elbow (4) socket in vise. Turn elbow counterclockwise to remove nipple and nut from elbow socket
		e. Hose (7)		Turn hose clockwise out of elbow (4) socket; discard hose

WARNING

Dry cleaning solvent (P-D-680), used to clean parts is toxic and flammable. Wear protective goggles and gloves and use only in a well ventilated area. Avoid contact with skin, eyes, and clothes and don't breathe vapors. Do not use near open flame or excessive heat and don't smoke when using it. Failure to do so could cause serious injury. If you become dizzy while using cleaning solvent, get fresh air and medical attention immediately. If contact with skin or clothes is made, flush with large amounts of water. If contact with eyes is made, wash eyes with water and seek medical aid immediately.

13	Fittings	Fitting (6) and elbow (4)	Clean	Use cleaning solvent P-D-680; allow to air dry. Use wire brush to remove all hose residue from socket and nipple of fitting or elbow
14	Hose (7)	a. Hose (7)	Cut to proper length	Use new hose; use old hose for determining proper length required. Cut hose square using fine tooth hacksaw
		b. Fitting (6)		Place fitting socket in vise as shown
		c. Hose (7)		Screw hose counterclockwise into socket until hose bottoms; back hose off 1/4 turn
		d. Fitting nipple		Oil nipple threads and inside of hose liberally using hydraulic oil
		e. Fitting socket		Screw nipple clockwise into socket and hose. Tighten nipple until snug against socket
		f. Elbow (4)		Place elbow socket in vise
		g. Hose (7)		Screw hose (7) counterclockwise into socket until hose bottoms; back off hose 1/4 turn

2-28. ENGINE WARNING KIT MAINTENANCE (CONT)

STEP	LOCATION	ITEM	ACTION	REMARKS
REPAIR (cont)				
14 (cont)		h. Elbow (4) nipple and nut		Oil nipple threads and inside of hose liberally using hydraulic oil. Screw nipple clockwise into socket and hose until nut near nipple bottoms on socket. Remove hose from vise

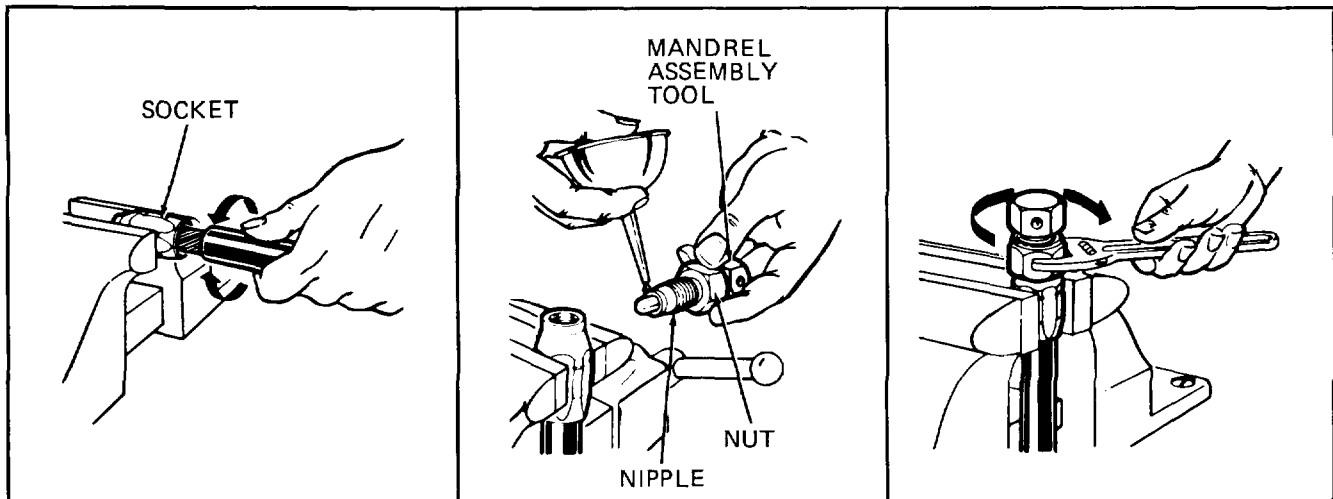

TA236149

INSTALLATION

NOTE

Apply thread sealant to all pipe threads to prevent oil leakage.

15	Oil cooler	a. Bracket (15) b. Two lock washers (14) and capscrews (13)	Position Install and tighten	On oil cooler
16	Engine, front bottom left	a. Oil cooler b. Water pump c. Radiator make-up line and heater pump line d. Lower radiator hose	Install Install Install Install	Refer to TM 9-2815-205-34 Refer to TM 9-2815-205-34 Para 2-73e Para 2-15c

2-28. ENGINE WARNING KIT MAINTENANCE (CONT)
--

STEP	LOCATION	ITEM	ACTION	REMARKS
INSTALLATION (cont)				
17	Engine, front left side	a. Nipple (12) b. Tee (11) c. Adapter (10) d. Tee (9) e. Elbow (8) f. Fitting (5) g. Hose (7) h. Fitting (6) i. Elbow (4)	Install Install Install Install Install Connect and tighten Route Connect and tighten Connect and tighten	On bracket (15) On nipple (12) On engine In tee (9) To tee (12) Between adapter (10) and tee (9) To tee (9) To adapter (10)
18	Engine, left side	a. Oil pressure sender (3) b. Oil pressure warning sender (2)	Install Install	Para 2-32a Para 2-32a
19	Right thermostat housing	Alarmstat sensor (1)	Install	Para 2-32c
20	Cab tilt pump	Cab	Lower	To normal operating position

2-29. WATER LEVEL WARNING KIT MAINTENANCE

This task covers:

- a. Testing
- b. Removal
- c. Cleaning
- d. Inspection
- e. Installation

INITIAL SETUP

Tools

No. 1 Common Organizational Maintenance Tool Kit
 Socket wrench set connectors
 Screwdriver
 Safety glasses
 Multimeter
 Automotive Mechanic's Tool Kit
 Combination wrench set
 No. 2 Common Organizational Maintenance Tool Kit
 C-clamp
 Tool kit, electrical connector (M878A1 Operator's Manual)
 Crimping tool
 Wire stripper

Electrical tape Item 37, Appendix C
 Two crimp
 FSCM 90915 PN 90828080
 Two wood blocks
 Jumper wire

Personnel Required

Two Wheel Vehicle Mechanics MOS 63B

References

TM 9-2320-285-10

Equipment Condition

Paragraph Condition Description

Materials/Parts

Cleaning solvent Item 1, Appendix C
 Clean cloths Item 2, Appendix C
 Detergent Item 27, Appendix C
 Thread sealant Item 29, Appendix C

Vehicle parked on level surface, engine off, and parking brake applied.

STEP	LOCATION	ITEM	ACTION	REMARKS
------	----------	------	--------	---------

ON-VEHICLE TESTING

1	Engine compartment	Radiator and overflow reservoir	Check coolant level	Refer to Operator's manual
2	Tractor cab	a. Key switch	Place in on position	Do not start engine. WATER LEVEL warning light and OIL PRESSURE warning light should be lit and alarm bell should sound. If WATER TEMP light is lit, check diodes (para 2-35f) WATER LEVEL warning light and OIL PRESSURE warning light should go out and alarm bell should stop sounding. Operate engine at idle speed until warm
		b. Engine	Start	

2-29. WATER LEVEL WARNING KIT MAINTENANCE (CONT)

Key

- 1. Crimp connector
- 2. Crimp connector
- 3. Clamp
- 4. Clamp
- 5. Hose
- 6. Hose

- 7. Capscrews (2)
- 8. Nuts (2)
- 9. Bracket
- 10. Water level sensor
- 11. Connector
- 12. Elbow
- 13. Connector
- 14. Capscrews (2)
- 15. Lock washers (2)
- 16. Clamps (2)
- 17. Clamp
- 18. Clamp
- 19. Clamps (4)
- 20. Tees (2)

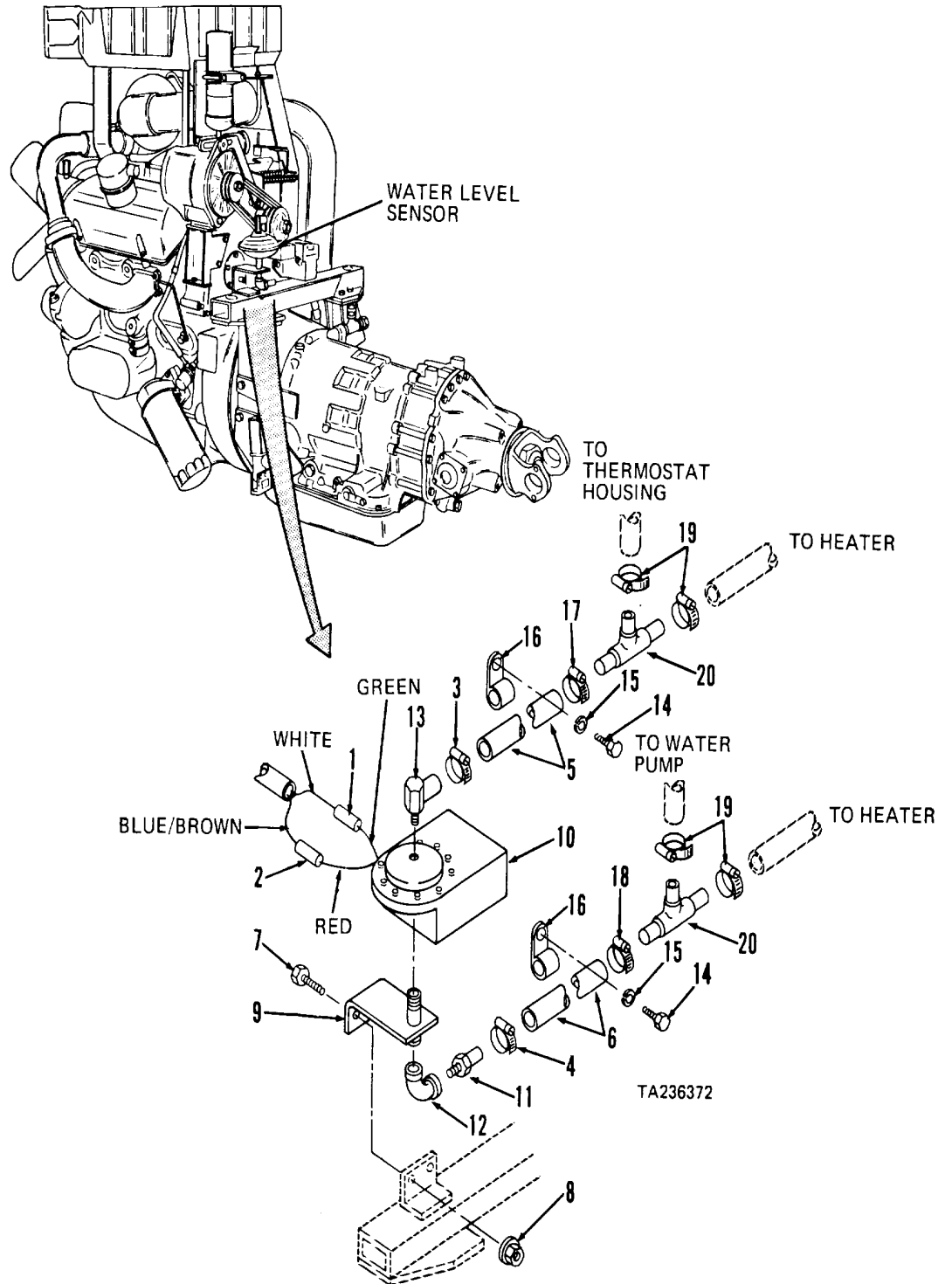

2-29. WATER LEVEL WARNING KIT MAINTENANCE (CONT)

STEP	LOCATION	ITEM	ACTION	REMARKS
ON-VEHICLE TESTING (cont)				
<u>WARNING</u>				
Be careful when performing the following step not to come in contact with rotating fan. To do so will cause serious injury. If you are injured by rotating fan, obtain medical aid immediately.				
3	Engine, left side	Hose (5)	a. Clamp	Use two wooden blocks and C-clamp to block flow of water to water level sensor (10). WATER LEVEL warning light should be lit and alarm bell should sound
			b. Unclamp	Remove C-clamp and wooden blocks; WATER LEVEL warning light should go out and alarm bell should stop sounding
4	Tractor cab	Key switch	Place in off position	Turns engine off
5	Cab tilt pump	Cab	Tilt 45 degrees	
6	Engine, rear, water level sensor	a. Blue/brown wire lead b. White wire lead c. Multimeter	Disconnect and tape Disconnect a. Connect b. Observe	Cut wire as close to crimp connector (2) as possible Cut wire as close to crimp connector (1) as possible Across water level sensor green and red wire leads Multimeter should indicate zero ohms. If multimeter indicates infinity, water level sensor is defective and must be replaced (step 13 below).
7	Cab tilt pump	Cab	Lower	To normal operating position
8	Tractor cab	Key switch	Place in on position	Start engine and operate at idle speed

2-29. WATER LEVEL WARNING KIT MAINTENANCE (CONT)

STEP	LOCATION	ITEM	ACTION	REMARKS
ON-VEHICLE TESTING (cont)				
9	Water level sensor	Multimeter	Observe	Multimeter should indicate infinity with engine operating. If multimeter indicates zero ohms, replace water level sensor (step 13 below)
10	Cab tilt pump	Cab	Tilt 45 degrees	
11	Water level sensor	a. Multimeter	Disconnect	To water level sensor red wire lead using crimp connector
		b. Blue/brown wire lead	Connect	
11	Water level sensor	c. White wire lead	Connect	To water level sensor green wire lead using crimp connector
12	Cab tilt pump	Cab	Lower	To normal operating position
REMOVAL				
13	Cab tilt pump	Cab	Tilt 45 degrees	
14	Engine compartment	Radiator	Drain	Para 2-15a(l)
NOTE				
Tag wire leads before disconnecting them to aid in installation.				
15	Water level sensor (10)	a. Crimp connectors (1 and 2)	Remove	Cut wires as close to connector as possible
		b. Clamps (3 and 4)	Loosen	
		c. Hoses (5 and 6)	Disconnect Remove	Don't remove clamps (3 and 4)
		d. Two capscrews (7) and nuts (8)		
		e. Bracket (9) and water level sensor (10)	Remove	From vehicle

2-29. WATER LEVEL WARNING KIT MAINTENANCE (CONT)

STEP	LOCATION	ITEM	ACTION	REMARKS
REMOVAL (cont)				
16	Bracket (9) and water level sensor (10)	a. Connector (11)	Remove	From elbow (12)
		b. Elbow (12)	Remove	From bracket (9)
		c. Connector (13)	Remove	From water level sensor (10)
		d. Bracket (9)	Remove	From water level sensor (10) by unscrewing it

NOTE

Perform the following steps only if hoses (5 and 6) and/or tees (20) require replacement.

17	Frame rail, left side	a. Two capscrews (14) and lock washers (15)	Remove	
		b. Two clamps (16)	Remove	
		c. Clamps (3 and 4)	Remove	
		d. Clamps (17 and 18)	Loosen	
		e. Hoses (5 and 6)	Remove	Remove clamps (17 and 18) from hoses
		f. Four clamps (19) Loosen		
		g. Two tees (20)	Remove	

CLEANING

18		a. Hoses (5 and 6)	Clean	Use clean cloth moistened with mild detergent; dry using clean cloths
----	--	--------------------	-------	---

WARNING

Dry cleaning solvent (P-D-680), used to clean parts is toxic and flammable. Wear protective goggles and gloves and use only in a well ventilated area. Avoid contact with skin, eyes, and clothes and don't breathe vapors. Do not use near open flame or excessive heat and don't smoke when using it. Failure to do so could cause serious injury. If you become dizzy while using cleaning solvent, get fresh air and medical attention immediately. If contact with skin or clothes is made, flush with large amounts of water. If contact with eyes is made, wash eyes with water and seek medical aid immediately.

		b. Remaining parts	Clean	Use cleaning solvent P-D-680; dry using clean cloths
--	--	--------------------	-------	--

2-29. WATER LEVEL WARNING KIT MAINTENANCE (CONT)

STEP	LOCATION	ITEM	ACTION	REMARKS
INSPECTION				
19		a. Clamps (3, 4, 17, 18, and 19)	Inspect for: wear damage	Replace if defects observed
		b. Hoses (5 and 6)	Inspect for: cracks deterioration	Replace if defects observed
		c. Two tees (20)	Inspect for: cracks damage	Replace if defects observed
		d. Remaining parts	Inspect for: cracks wear damaged threads	Replace as necessary

INSTALLATION

NOTE

When reinstalling parts use pipe thread compound on all fitting/elbow threads to prevent leakage.

20	Frame rail, left side	a. Four clamps (19)	Position	On end of hoses routed to heater, thermostat housing and water pump
		b. Two tees (20)	Install	In hose ends
		c. Clamps (17 and 18)	Install	On end of hoses (5 and 6)
		d. Hoses (5 and 6)	Install	On end of tees (20)
		e. Clamps (17 and 18)	Position and tighten	On end of hoses (5 and 6)
		f. Two clamps (16)	Position	On hoses (5 and 6)
		g. Two lock washers (15) and capscrews (14)	Install and tighten	
21	Water level sensor (10)	a. Bracket (9)	Install	Screw clockwise into water level sensor (10)
		b. Connector (13)	Install	In water level sensor (10)
		c. Elbow (12)	Install	On bracket (9) pipe nipple
		d. Connector (11)	Install	In elbow (12)

2-29. WATER LEVEL WARNING KIT MAINTENANCE (CONT)

STEP	LOCATION	ITEM	ACTION	REMARKS
INSTALLATION (cont)				
22	Transmission mount	a. Water level sensor (10) and bracket (9)	Position	
		b. Two capscrews (7) and nuts (8)	Install	Secures bracket (9)
		c. Hoses (5 and 6)	Connect	To connectors (11 and 13)
		d. Clamps (3 and 4)	Position and tighten	
23	Water level sensor (10)	a. Red and green wires	Strip 1/4 inch insulation from ends	
		b. Engine harness wire leads (white and blue/brown)	Strip 1/4 inch insulation from ends	
		c. Crimp connectors (1 and 2)	Install and crimp securely	Route wire leads into crimp connector as tagged in step 15 above
24	Radiator	Fill neck	Fill with coolant	Para 2-15a(l)

2-30. 24V INVERTER MAINTENANCE

- This task covers:
- a. Fuse Replacement
 - b. Removal
 - c. Cleaning
 - d. Inspection/Repair
 - e. Installation

INITIAL SETUP

Tools

No. 1 Common Organizational Maintenance

Tool Kit

- Socket wrench set
- Screwdriver
- Safety glasses
- Socket wrench extension
- Socket wrench handle
- Tool kit, electrical connector
- Multimeter

Materials/Parts

Cleaning

- solvent Item 1, Appendix C
- Clean cloths Item 2, Appendix C
- Tags Item 14, Appendix C
- Detergent Item 27, Appendix C
- Electrical tape Item 37, Appendix C
- Tie straps FSCM 96906 PN MS3667-1-9
- Electrical terminals FSCM 90915 PN 97420027

2-34a

Personnel Required

Wheel Vehicle Mechanic MOS 63B

Equipment Condition

Paragraph	Condition Description
	Vehicle parked on level surface, engine off, and parking brake applied.
	Cab tilted 45 degrees.
	Trailer light cables unplugged from tractor receptacles.
	Battery ground cable disconnected.

KEY

- 1. Fuse caps (2)
- 2. 30-ampere fuse
- 3. 20-ampere fuse
- 4. Screws (9)
- 5. Nuts (4)
- 6. Lock washers (4)
- 7. Inverter
- 8. Nuts (6)
- 9. Lock washers (6)
- 10. Nuts (6)
- 11. Lock washers (6)
- 12. Circuit breakers (6)
- 13. Locknuts (2)
- 14. Bracket
- 15. Screws (7)
- 16. Boot
- 17. Nuts (2)
- 18. Lock washers (2)
- 19. Capscrews (2)
- 20. 12-volt receptacle
- 21. Screw
- 22. Washer
- 23. Plastic tubing
- 24. Nuts (4)
- 25. Lock washers (4)
- 26. Capscrews (4)
- 27. 24-volt receptacle
- 28. Electrical wires (4)
- 29. 7-wire cable
- 30. Plastic tubing
- 31. Electrical wires (3)
- 32. 7-wire cable
- 33. Clamp
- 34. Cover
- 35. Electrical terminals (16)

2-30. 24V INVERTER MAINTENANCE (CONT)

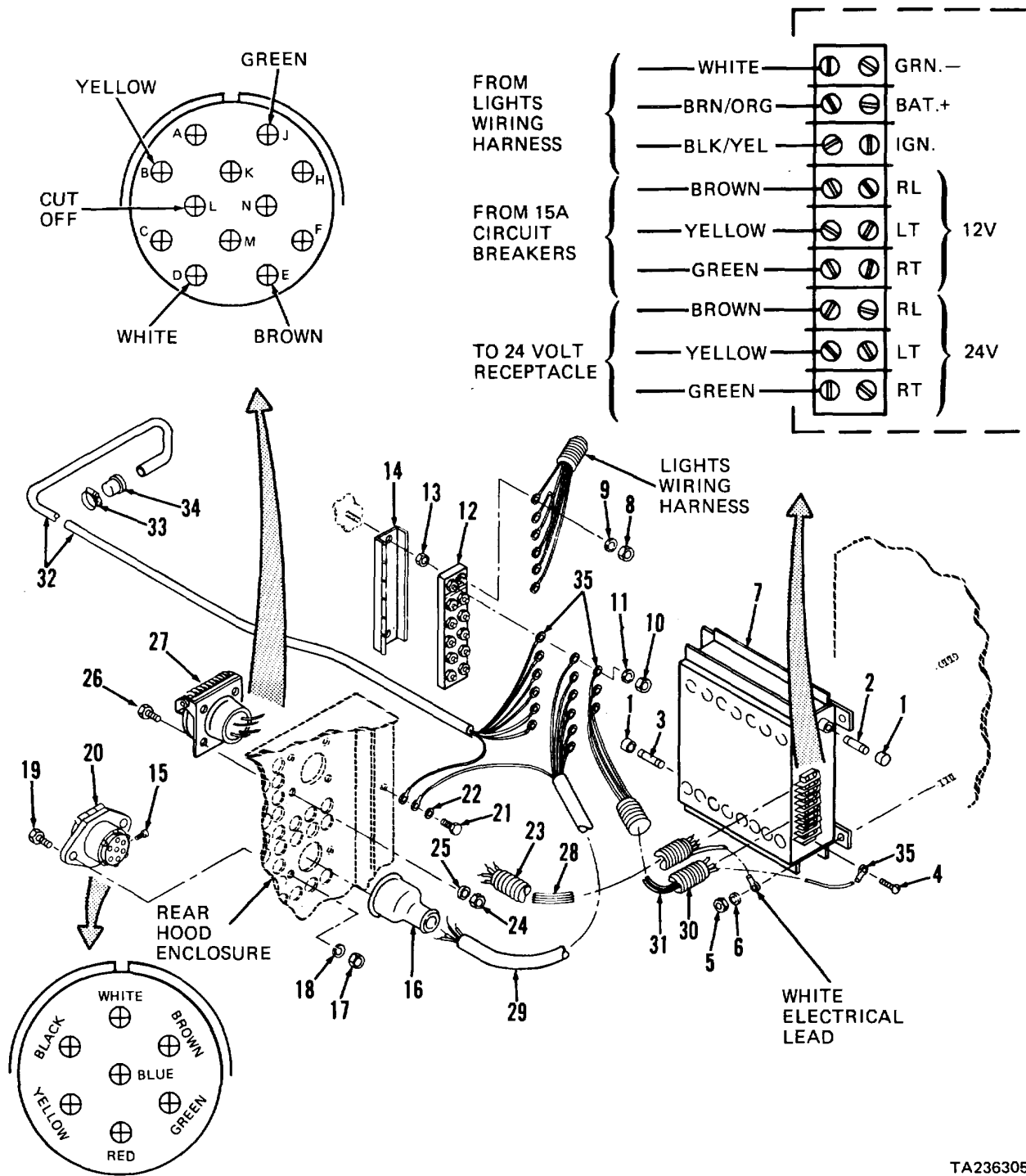

TA236305

2-30. 24V INVERTER MAINTENANCE (CONT)

STEP	LOCATION	ITEM	ACTION	REMARKS
FUSE REPLACEMENT				
1	Inverter (7)	a. Two fuse caps (1)	Remove	Push in, turn counterclockwise, and pull
		b. Fuses (2 and 3)	a. Remove b. Test	Pull from fuse caps (1) Set multimeter to X1 ohms range and connect test leads to ends of fuse. Replace fuse if multimeter indicates open circuit (infinity)
		c. Fuses (2 and 3)	Position	Push into fuse caps (1)
		d. Fuse caps (1) with fuses (2 and 3)	Install	Push in and turn clockwise

REMOVAL

WARNING

Be sure you disconnect battery ground cable before proceeding. Failure to do so could cause death or serious injury due to electrical shock. If you receive an electrical shock, seek medical aid immediately.

2	Inverter (7)	a. Nine electrical leads	Tag	Tag leads at inverter (7) terminal strip
---	-----------------	--------------------------	-----	--

CAUTION

Do not loosen or remove the brass-colored screws on inverter (7) terminal strip. Remove the chrome-colored screws (4) only.

3	Circuit breakers (12)	b. Nine screws (4)	Remove	
		c. Nine electrical leads	Disconnect	From terminal strip
		d. Four nuts (5) and lock washers (6)	Remove	Support inverter (7)
		e. White electrical lead	a. Tag	
		f. Inverter (7)	b. Disconnect Remove	From inverter mounting stud
		a. Lights wiring harness electrical leads	Tag	Six leads located on same side of circuit breakers (12)

2-30. 24V INVERTER MAINTENANCE (CONT)
--

STEP	LOCATION	ITEM	ACTION	REMARKS
REMOVAL (cont)				
3 (cont)		b. Six nuts (8) and lock washers (9)	Remove	From circuit breakers (12)
		c. Lights wiring harness electrical leads	Disconnect	From circuit breakers (12)
		d. 15 electrical leads breakers (12)	Tag	Tag 15 remaining electrical leads connected to circuit
		e. Six nuts (10) and lock washers (11)	Remove	From circuit breakers (12)
		f. 15 electrical leads	Disconnect	From circuit breakers (12)
		g. Six circuit breakers (12)	Remove	Snap out from bracket (14)
		h. Two locknuts (13)	Remove, if necessary	Support bracket (14)
		i. Bracket (14)	Remove	From mounting studs

NOTE

Remove all clamps and tie straps as necessary for cable or wire removal in the following steps. Note locations to aid installation.

4	Rear hood enclosure	a. Electrical tape	Remove	From boot (16) and 7-wire cable (29)
		b. Boot (16)	Slide back	Onto 7-wire cable (29) so screws (15) are accessible
		c. Seven electrical leads	Tag	Tag 7-wire cable (29) leads at 12-volt receptacle (20)
		d. Seven screws (15)	Remove	
		e. 7-wire cable (29) leads	Disconnect	From 12-volt receptacle (20)
		f. Boot (16)	Remove	Pull from 7-wire cable (29)
		g. Two nuts (17), lock washers (18), and capscrews (19)	Remove	Support 12-volt receptacle (20)
		h. 12-volt receptacle (20)	Remove	
		i. Screw (21) and washer (22)	Remove	If necessary for removal of 7-wire cable (29 or 32)

2-30. 24V INVERTER MAINTENANCE (CONT)
--

STEP	LOCATION	ITEM	ACTION	REMARKS
REMOVAL (cont)				
4 (cont)				
NOTE				
Perform steps 4j thru 4m below only if necessary to remove 24-volt receptacle (27) with wires (28).				
		j. Electrical tape	Remove	From plastic tubing (23) and 24-volt receptacle (27)
		k. Plastic tubing (23)	Remove	Pull open at slit and remove from electrical wires (28)
		l. Four nuts (24), lock washers (25), and capscrews (26)	Remove	
		m. 24-volt receptacle (27) with four electrical wires (28)	Remove	Pull electrical wires (28) through receptacle cutout in rear hood enclosure
		n. 7-wire cable (29)	Remove	
		o. Electrical tape	Remove	From plastic tubing (30)
		p. Plastic tubing (30)	Remove	Pull open at slit and remove from electrical wires (31)
		q. Three electrical wires (31)	Remove	From tractor
5	Right hand frame rail and rear crossmember	a. 7-wire cable (32)	Remove, if necessary	Remove all clamps and tie straps necessary to remove cable (32) from frame rail and crossmember
		b. Clamp (33) and cover (34)	Remove	From 7-wire cable (32)

2-30. 24V INVERTER MAINTENANCE (CONT)

STEP	LOCATION	ITEM	ACTION	REMARKS
CLEANING				
6		a. Circuit breakers (12), 7-wire cables (29 and 32), receptacles (20 and 27), and inverter (7) exterior	Clean	Wipe with clean, dry cloth only
		b. Boot (16), cover (34), and plastic tubing (23 and 30)	Clean	Use clean cloth moistened with mild detergent; dry using clean cloths

WARNING

Dry cleaning solvent (P-D-680), used to clean parts is toxic and flammable. Wear protective goggles and gloves and use only in a well ventilated area. Avoid contact with skin, eyes, and clothes and don't breathe vapors. Do not use near open flame or excessive heat and don't smoke when using it. Failure to do so could cause serious injury. If you become dizzy while using cleaning solvent, get fresh air and medical attention immediately. If contact with skin or clothes is made, flush with large amounts of water. If contact with eyes is made, wash eyes with water and seek medical aid immediately.

Compressed air must not exceed 30 psi. Wear safety glasses when drying parts with compressed air. Failure to do so could cause serious injury to eyes and possible blindness. If you hurt your eyes or if a foreign object is blown into your eyes, seek medical attention immediately.

c. All remaining metal parts	Clean	Use cleaning solvent P-D-680; dry thoroughly using compressed air
------------------------------	-------	---

2-30. 24V INVERTER MAINTENANCE (CONT)

STEP	LOCATION	ITEM	ACTION	REMARKS
INSPECTION/REPAIR				
7		a. Circuit breakers (12)	Inspect	Replace if cracked or otherwise defective
		b. Boot (16) and cover (34)	Inspect	Replace if cut, cracked, or deteriorated
		c. 12-volt receptacle (20)	Inspect	Replace if cracked, pins bent or missing, hinge broken, or threads damaged
		d. Electrical wires (31) and 7-wire cable (32)	Inspect	Replace if jacket or insulation cracked, cut, or frayed, or if conductors corroded or broken. Replace defective terminals (35) as follows: <ul style="list-style-type: none"> a. Cut wire as close to terminal as possible b. Strip 1/4-inch insulation from wire end c. Install new terminal; use crimping tool in electrical connector tool kit
		e. 7-wire cable (29)	Inspect	Replace if jacket or insulation cracked, cut, or frayed, or if conductors or terminals corroded or broken
		f. Electrical wires (28)	Inspect	Replace 24-volt receptacle (27) with wires as an assembly if insulation cut, cracked, or frayed, or if conductors corroded or broken
		g. 24-volt receptacle (27)	Inspect	Replace if shell cracked or deformed, or if hinge broken. Replace bent, corroded, or broken contacts using parts and tools in electrical connector tool kit
		h. Inverter (7)	Inspect	Replace if fuse holders, housing, or terminal strips cracked or broken or inverter otherwise defective
		i. Plastic tubing (23 and 30)	Inspect	Replace if cracked, chafed, or deteriorated

2-30. 24V INVERTER MAINTENANCE (CONT)

STEP	LOCATION	ITEM	ACTION	REMARKS
INSPECTION/REPAIR (cont)				
7 (cont)		j. All other parts	Inspect	Replace if cracked, broken, distorted, or threads damaged
INSTALLATION				
8	Right hand frame rail and rear crossmember	a. Cover (34) and clamp (33) b. 7-wire cable (32)	Install Route and secure	On 7-wire cable (32) Install all clamps and tie straps as noted during removal
9	Tractor cab under hood at rear	a. Plastic tubing (30) b. 24-volt receptacle (27) with electrical wires (28) c. Four capscrews (26), lock washers (25), and nuts (24) d. Plastic tubing (23) e. 7-wire cables (29 and 32) white wires f. Screw (21) and washer (22)	a. Install b. Tape c. Position Position Install and tighten a. Install b. Tape Position Install	Pull open at slit and install around three electrical wires (31) Wrap new electrical tape around plastic tubing at locations noted during removal Route plastic tubing with electrical wires (31) in tractor Push electrical wires (28) through receptacle cutout in rear hood enclosure; align receptacle mounting holes with cover hinge at the top Pull open at slit and install around electrical wires (28) Wrap new electrical tape around plastic tubing and 24-volt receptacle at locations noted during removal At rear hood enclosure post Secures white wires (ground leads)

2-30. 24V INVERTER MAINTENANCE (CONT)

STEP	LOCATION	ITEM	ACTION	REMARKS
INSTALLATION (cont)				
9 (cont)		g. 12-volt receptacle (20)	Position	In rear hood enclosure; align receptacle mounting holes with cover hinge at the top
		h. Two capscrews (19), lock washers (18), and nuts (17)	Install and tighten	
		i. Boot (16)	Install	Push onto 7-wire cable (29), small diameter end first
		j. 7-wire cable (29) leads	Connect	To 12-volt receptacle (20) as tagged
		k. Seven screws (15)	Install and tighten	
		l. Boot (16)	Slide	Onto 12-volt receptacle (20) forward
		m. Electrical tape	Install	Wrap new electrical tape around 7-wire cable (29) and 12-volt receptacle (20) as noted during removal
10	Circuit breakers (12)	a. Bracket (14)	Position	On two mounting studs
		b. Two locknuts (13)	Install and tighten	Secures bracket (14)
		c. Six circuit breakers (12)	Install	Snap into bracket (14)
		d. Lights wiring harness electrical leads	Connect	To same side of circuit breakers (12) as tagged

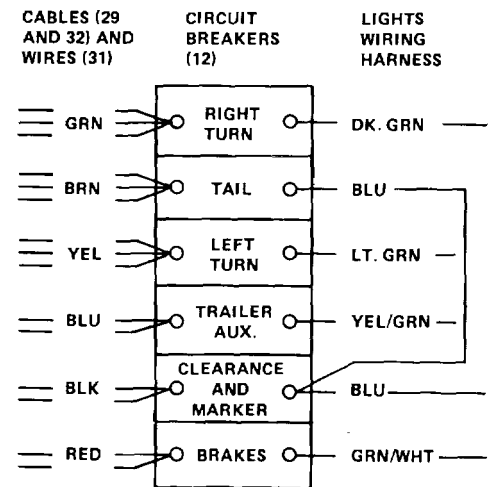

TA236187

2-30. 24V INVERTER MAINTENANCE (CONT)

STEP	LOCATION	ITEM	ACTION	REMARKS
INSTALLATION (cont)				
10 (cont)		e. Six nuts (8) and lock washers (9)	Install and tighten	Secures electrical leads to input side of circuit breakers
		f. 15 electrical leads	Connect	To output (remaining) side of circuit breakers as tagged
		g. Six nuts (10) and lock washers (11)	Install and tighten	Secures electrical leads to output side of circuit breakers (12)
11	Inverter (7)	a. Inverter (7)	Position	On four mounting studs
		b. White electrical lead	Connect	Over inverter mounting stud
		c. Four nuts (5) and lock washers (6)	Install and tighten	Secures inverter (7) and white electrical lead
		d. Nine electrical leads	Connect	To inverter (7) terminal strip as tagged
		e. Nine screws (4)	Install and tighten	Secures electrical leads to inverter (7) terminal strip
12	Cables, wires, and harness	Clamps and tie straps	Install	At locations noted during removal
13	Cab tilt pump	Tractor cab	Lower	To normal operating position
14	Battery box	Battery ground cable	Connect	Para 2-34a
15	Tractor cab	Brake, parking, turn signal, and clearance lights	Check	For proper operation in tractor, 12-volt trailer, and 24-volt trailer

2-31. LIGHT SYSTEMS MAINTENANCE

a. Headlights.

- This task covers:
- a. Removal
 - b. Cleaning
 - c. Inspection
 - d. Repair
 - e. Installation

INITIAL SETUP

Tools

No. 1 Common Organizational Maintenance

Tool Kit

- Screwdriver
- Safety glasses
- Tool kit, electrical connector
- Crimping tool
- Wire stripper

Automotive Mechanic's Tool Kit

Pliers

Mechanical headlight aimer

Personnel Required

Wheel Vehicle Mechanic MOS 63B

Equipment Condition

Paragraph Condition Description

Vehicle parked on level surface, engine off, and parking brake applied.

Materials/Parts

- Cleaning solvent Item 1, Appendix C
- Clean cloths Item 2, Appendix C
- Fine sandpaper Item 4, Appendix C

STEP	LOCATION	ITEM	ACTION	REMARKS
------	----------	------	--------	---------

REMOVAL

1	Tractor, front	a. Screw (1), mounting (2), and clip (3)	Remove	Do not separate clip (3) from mounting (2) unless replacement is required
		b. Three screws (4) and retainer (5)	Remove	
		c. Headlight (6)	Remove	Pull from lampholder (14); then unplug connector (16)

NOTE

Perform step 2 below only if replacement of housing assembly (12 thru 16) is required.

2	Headlight housing (12)	a. Three screws (7)	Remove	Support housing (12)
		b. Plug (8)	Unplug	From front chassis harness connector

2-31. LIGHT SYSTEMS MAINTENANCE (CONT)

a. Headlights (cont).

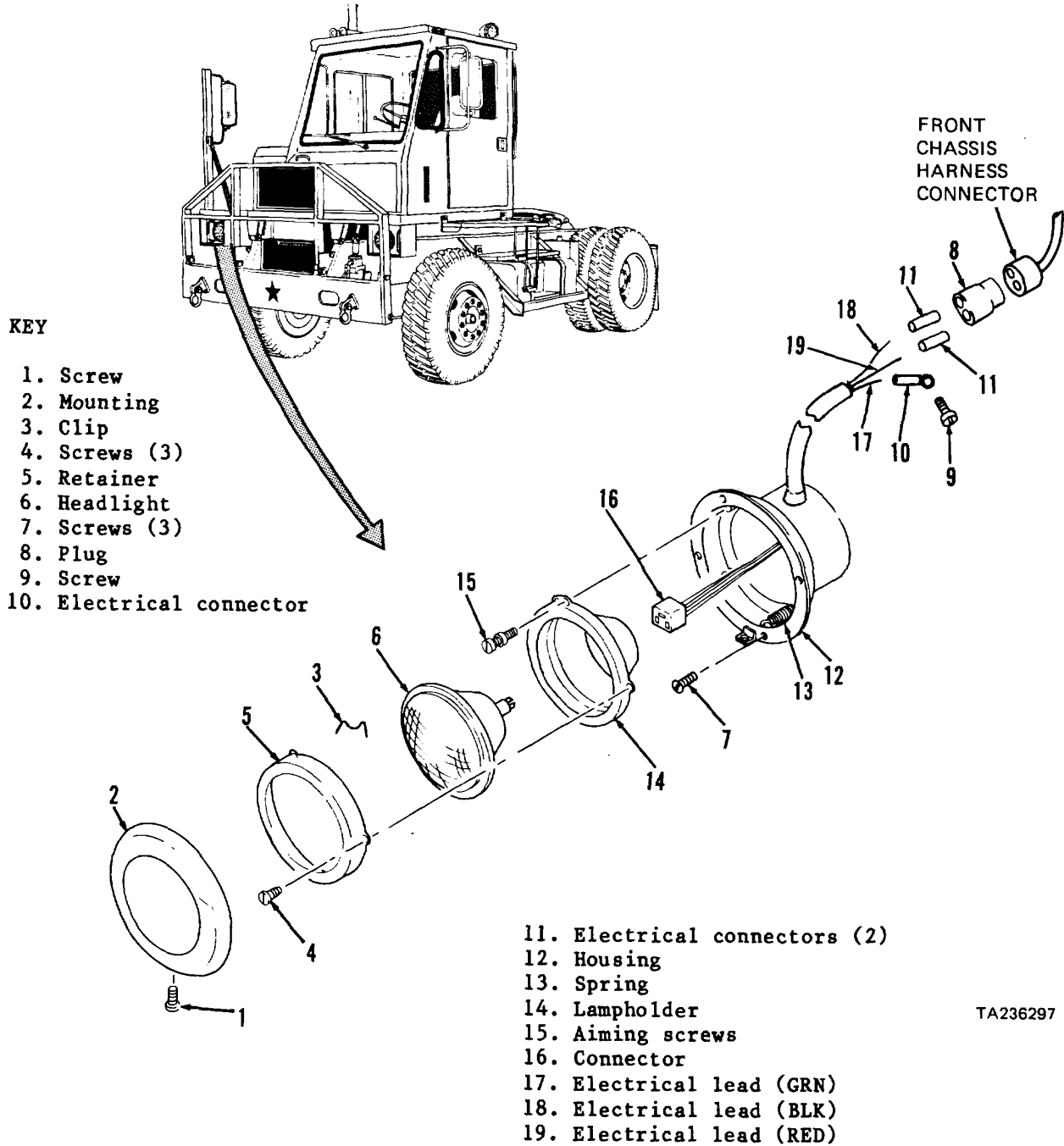

TA236297

2-31. LIGHT SYSTEMS MAINTENANCE (CONT)

a. Headlights (cont).

STEP	LOCATION	ITEM	ACTION	REMARKS
REMOVAL (cont)				
2 (cont)		c. Screw (9) with electrical connector (10)	Remove	
		d. Headlight housing assembly (12 thru 16)	Remove	As an assembly
CLEANING				
3		a. Headlight (6)	Clean	Wipe with clean cloth moistened with soapy water or commercial glass cleaner

WARNING

Dry cleaning solvent (P-D-680), used to clean parts is toxic and flammable. Wear protective goggles and gloves and use only in a well ventilated area. Avoid contact with skin, eyes, and clothes and don't breathe vapors. Do not use near open flame or excessive heat and don't smoke when using it. Failure to do so could cause serious injury. If you become dizzy while using cleaning solvent, get fresh air and medical attention immediately. If contact with skin or clothes is made, flush with large amounts of water. If contact with eyes is made, wash eyes with water and seek medical aid immediately.

Compressed air must not exceed 30 psi. Wear safety glasses when drying parts with compressed air. Failure to do so could cause serious injury to eyes and possible blindness. If you hurt your eyes or if a foreign object is blown into your eyes, seek medical attention immediately.

b. All metal parts	Clean	Wipe with clean cloth moistened with cleaning solvent P-D-680; dry with compressed air or clean cloths
--------------------	-------	--

2-31. LIGHT SYSTEMS MAINTENANCE (CONT)

a. Headlights (cont).

STEP	LOCATION	ITEM	ACTION	REMARKS
INSPECTION				
4		a. Headlight (6)	Inspect	Replace if filaments burned out, or headlight broken. Polish corroded terminals to brightness with fine sandpaper
		b. Lampholder (14) and housing (12)	Inspect	Replace headlight assembly if cracked, broken, or distorted
		c. All other parts	Inspect	Replace if cracked, broken, distorted, or threads damaged

REPAIR

NOTE

Perform step 5 below only if necessary for replacement of headlight housing assembly (12 thru 16) or connectors (10 and 11).

5	Headlight housing assembly (12 thru 16)	a. Plug (8)	Remove	From connectors (10 and 11)
		b. Electrical connectors (10 and 11)	Remove and discard	Only if necessary to replace connector. Cut wire as close as possible to connector
		c. Electrical leads (17, 18, and 19)	Strip	Strip 1/4 inch of insulation from wire ends
		d. New electrical connector (10)	Install	Crimp onto green electrical lead (17)
		e. Two new electrical connectors (11)	Install	Crimp onto electrical leads (18 and 19)
		f. Plug (8)	Install	On connectors (11) with black electrical lead (18) at indexing key of plug (8)

INSTALLATION

NOTE

Perform step 6 below only if headlight housing assembly (12 thru 16) was removed.

2-31. LIGHT SYSTEMS MAINTENANCE (CONT)

a. Headlights (cont).

STEP	LOCATION	ITEM	ACTION	REMARKS
INSTALLATION (cont)				
6	Headlight housing (12)	a. Electrical connector (10)	Position	
		b. Screw (9)	Install and tighten	
		c. Plug (8)	Connect	To front chassis harness connector
		d. Headlight housing assembly (12 thru 16)	Position	
		e. Three screws (7)	Install and tighten	
7	Tractor, front	a. Headlight (6)	Install	Push on connector (16); then hold against lampholder (14)
		b. Retainer (5) and three screws (4)	Install	
		c. Headlight (6)	Aim	Use mechanical aimer to properly aim headlight beam.
				aiming screws (15) as
		d. Clip (3)	Attach	ary. If mechanical aimer is not available, adjust headlight high beam to be centered in road 300 feet in front of fully loaded tractor
		e. Mounting (2) and screw (1)	Install	To mounting (2), if removed Tighten screw (1)

Turn
necess-

2-31. LIGHT SYSTEMS MAINTENANCE (CONT)

b. Tail and Stop Lights.

This task covers: a. Removal c. Inspection
 b. Cleaning d. Installation

INITIAL SETUP

Tools

No. 1 Common Organizational Maintenance
 Tool Kit
 Screwdriver
 Multimeter

Personnel Required

Wheel Vehicle Mechanic MOS 63B

Equipment Condition

Paragraph Condition Description

Materials/Parts

Clean cloths Item 2, Appendix C
 Fine sandpaper Item 4, Appendix C
 Detergent solution Item 27, Appendix C

Parked on level surface; parking brake applied; engine off.

KEY

1. Grommet
2. Sealed lamp unit
3. Connector
4. Screw

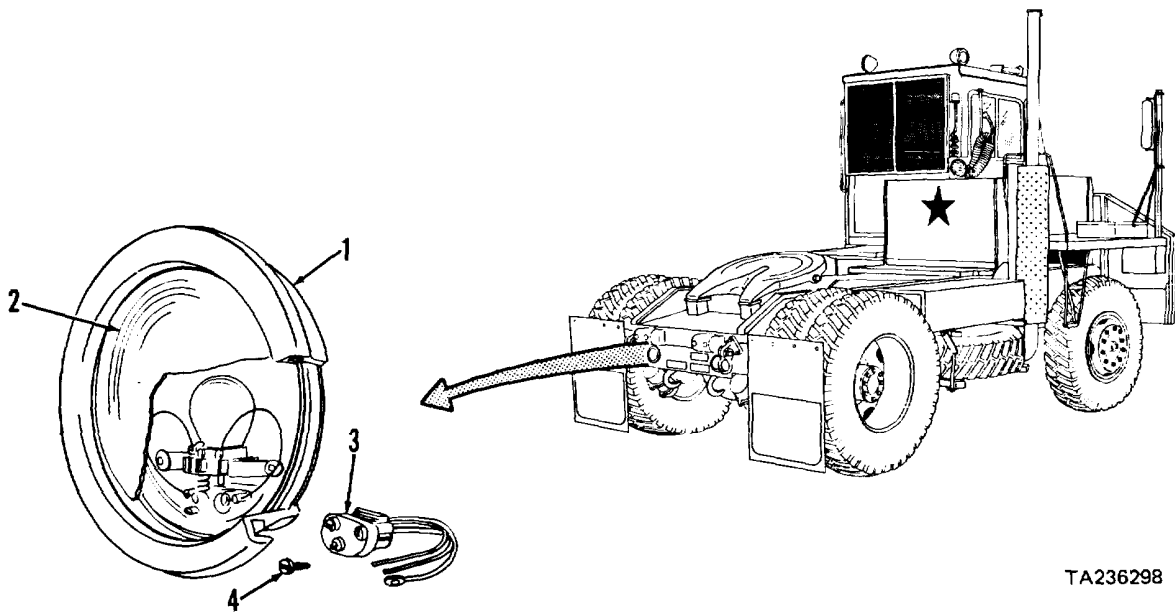

TA236298

2-31. LIGHT SYSTEMS MAINTENANCE (CONT)

b. Tail and Stop Lights (cont).

STEP	LOCATION	ITEM	ACTION	REMARKS
REMOVAL				
1	Tractor, rear	a. Grommet (1) and sealed lamp unit (2)	Remove	Pry out carefully
		b. Connector (3)	Unplug	From sealed lamp unit (2)
		c. Grommet (1) and sealed lamp unit (2)	Separate	
CLEANING				
2		a. Grommet (1)	Clean	Wipe with clean, dry cloth
		b. Sealed lamp unit (2)	Clean	Wipe with clean cloth moist with soapy water or glass cleaner. Dry thoroughly
INSPECTION				
3		a. Grommet (1)	Inspect	Replace if cracked, torn, or deteriorated
		b. Sealed lamp unit (2)	Inspect	Replace if cracked or broken. Polish corroded terminals to brightness with fine sandpaper. Use ohmmeter
		c. Screw (4) and wire connector (3)	Inspect	check lamp for continuity (low resistance circuit). Replace if defective Inspect for corrosion and good electrical contact to tractor frame
INSTALLATION				
4	Tractor, rear	a. Grommet (1)	Install	
		b. Connector (3) and sealed lamp unit (2)	Connect	
		c. Grommet (1)	Lubricate	Use detergent solution
		d. Sealed lamp unit (2)	Install	

2-31. LIGHT SYSTEMS MAINTENANCE (CONT)

c. Cab Interior Light (cont).

- This task covers: a. Removal c. Inspection
 b. Cleaning d. Installation

INITIAL SETUP

Tools

No. 1 Common Organizational Maintenance

Tool Kit

Screwdriver set

Safety glasses

Tool kit, electrical connector

Crimping tool

Wire stripper

Personnel Required

Wheel Vehicle Mechanic MOS 63B

Equipment Condition

Paragraph	Condition Description
	Vehicle parked on level surface, engine off, and parking brake applied.

Materials/Parts

Cleaning solvent

Item 1, Appendix C

Clean cloths

Item 2, Appendix C

Wire connector

FSCM 90915 PN 90003404

KEY

1. Cover
2. Lamp
3. Screws (4)
4. Wire connector
5. Light housing
6. Electrical lead (BLK)
7. Electrical lead (RED)

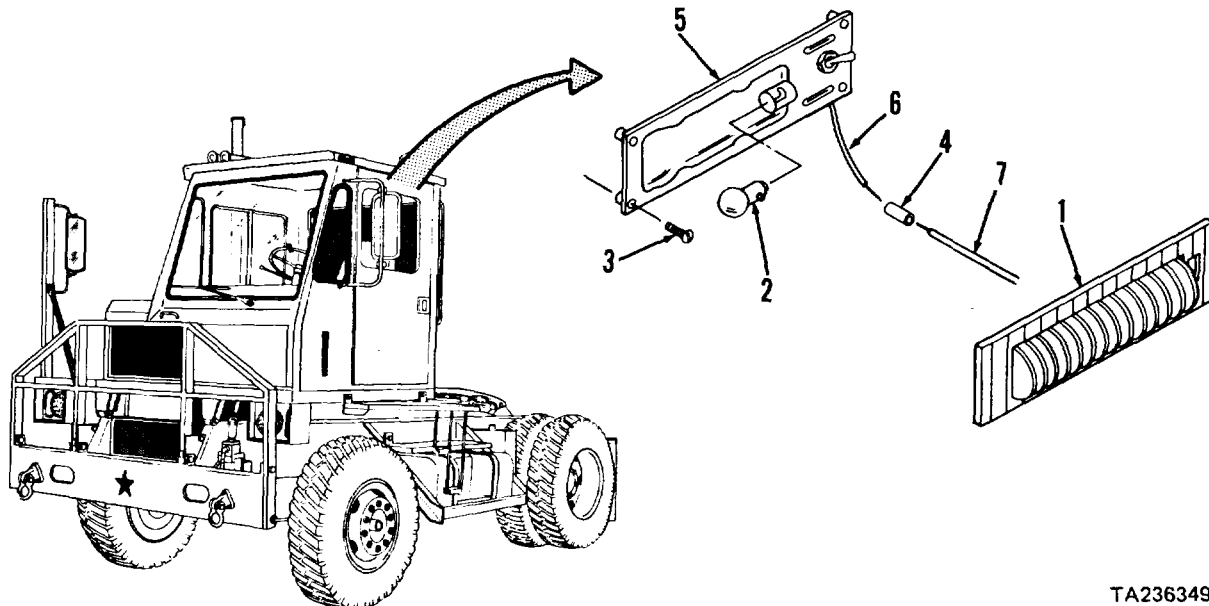

TA236349

2-31. LIGHT SYSTEMS MAINTENANCE (CONT)

c. Cab Interior Light (cont).

STEP	LOCATION	ITEM	ACTION	REMARKS
REMOVAL				
1	Cab, inside, left hand side, above door	a. Cover (1)	Remove	Pull off
		b. Lamp (2)	Remove	
		c. Four screws (3)	Remove	Support light housing (5)
		d. Wire connector (4)	Remove and discard	Continue to support light housing (5) and cut electrical leads (6 and 7) as close to wire connector as possible
		e. Light housing (5)	Remove	From cab
CLEANING				
2		a. Cover (1)	Clean	Rinse cover in clear water; dry with clean, dry cloth
		b. Light housing (5) and electrical leads (6 and 7)	Clean	Wipe with clean, dry cloth

WARNING

Dry cleaning solvent (P-D-680), used to clean parts is toxic and flammable. Wear protective goggles and gloves and use only in a well ventilated area. Avoid contact with skin, eyes, and clothes and don't breathe vapors. Do not use near open flame or excessive heat and don't smoke when using it. Failure to do so could cause serious injury. If you become dizzy while using cleaning solvent, get fresh air and medical attention immediately. If contact with skin or clothes is made, flush with large amounts of water. If contact with eyes is made, wash eyes with water and seek medical aid immediately.

Compressed air must not exceed 30 psi. Wear safety glasses when drying parts with compressed air. Failure to do so could cause serious injury to eyes and possible blindness. If you hurt your eyes or if a foreign object is blown into your eyes, seek medical attention immediately.

2-31. LIGHT SYSTEMS MAINTENANCE (CONT)

c. Cab Interior Light (cont).

STEP	LOCATION	ITEM	ACTION	REMARKS
CLEANING (cont)				
2 (cont)		c. Screws (3)	Clean	Use cleaning solvent P-D-680; dry with compressed air or clean cloths
INSPECTION				
3		a. Lamp (2)	Inspect	Replace if burned out or filament broken
		b. All other parts	Inspect	Replace if cracked, broken, or threads damaged
INSTALLATION				
4	Cab, inside, left hand side, above door	a. Electrical leads (6 and 7)	Strip	Strip 1/4 inch of insulation from wire ends
		b. New wire connector (4)	Install	Crimp onto electrical leads (6 and 7)
		c. Light housing (5)	Position	
		d. Four screws (3)	Install and tighten	
		e. Cover (1)	Install	Press onto light housing (5)

2-31. LIGHT SYSTEMS MAINTENANCE (CONT)

d. Front Turn Indicator Lights (cont).

This task covers: a. Removal c. Inspection
 b. Cleaning d. Installation

INITIAL SETUP

Tools

No. 1 Common Organizational Maintenance
 Tool Kit

Screwdriver set
 Safety glasses

Personnel Required

Wheel Vehicle Mechanic MOS 63B

Equipment Condition

Paragraph Condition Description

Parked on level surface; parking brake applied; engine off.

Materials/Parts

Clean cloths
 Fine sandpaper

Item 2, Appendix C
 Item 4, Appendix

KEY

1. Grommet
2. Sealed lamp unit
3. Connector

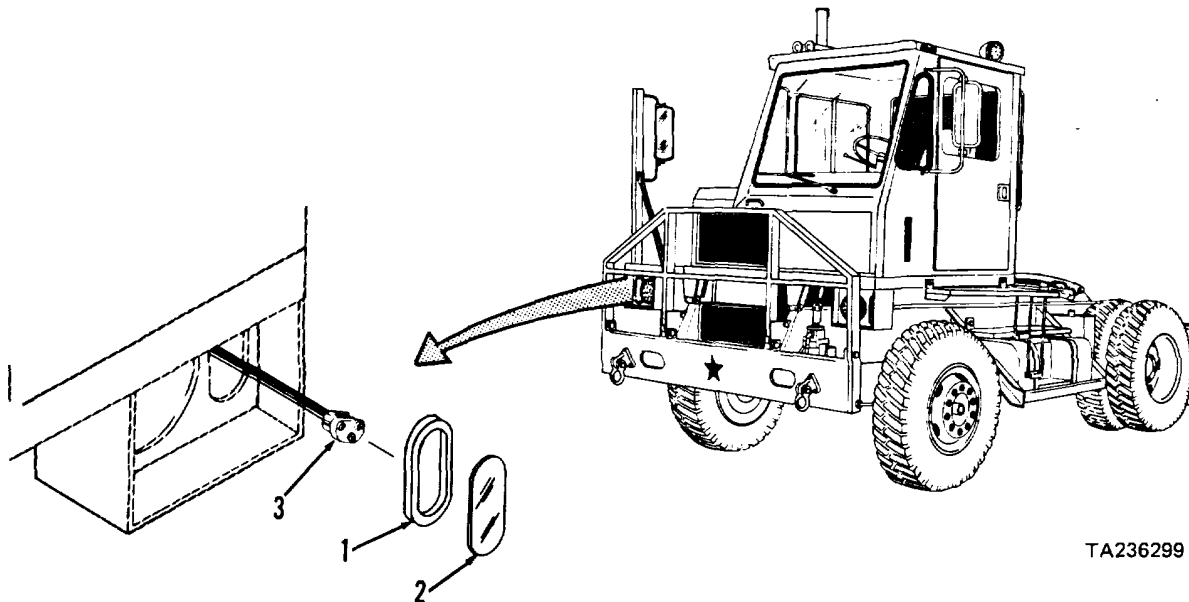

TA236299

2-31. LIGHT SYSTEMS MAINTENANCE (CONT)

d. Front Turn Indicator Lights (cont).

STEP	LOCATION	ITEM	ACTION	REMARKS
REMOVAL				
1	Tractor, front	a. Grommet (1) and sealed lamp unit (2)	Remove	
		b. Connector (3)	Unplug	From sealed lamp unit (2)
		c. Grommet (1) and sealed lamp unit (2)	Separate	
CLEANING				
2		a. Grommet (1)	Clean	Wipe with clean, dry cloth
		b. Sealed lamp unit (2)	Clean	Wipe with clean cloth moistened with soapy water or glass cleaner. Dry thoroughly
INSPECTION				
3		a. Grommet (1)	Inspect	Replace if cracked, torn, or deteriorated
		b. Sealed lamp unit (2)	Inspect	Replace as an assembly if cracked or broken. Polish corroded terminals to brightness with fine sandpaper. Set multimeter to X1 ohms range and check lamp filaments for continuity (low resistance circuit). Replace a defective lamp unit
		c. Connector (3) wire	Inspect	Inspect for corrosion and for good electrical contact
INSTALLATION				
4	Tractor, front	a. Grommet (1)	Install	In tractor mounting opening
		b. Connector (3) and sealed lamp unit (2)	Connect	
		c. Grommet (1)	Lubricate	With detergent solution
		d. Sealed lamp unit (2)	Install	Snap into grommet (1)

2-31. LIGHT SYSTEMS MAINTENANCE (CONT)

e. Marker Lights.

This task covers: a. Removal c. Inspection
 b. Cleaning d. Installation

INITIAL SETUP

Tools

No. 2 Common Organizational Maintenance
 Tool Kit

- Tool kit, electrical connector
- Crimping tool
- Wire stripper
- Screwdriver set
- Safety glasses

Personnel Required

Wheel Vehicle Mechanic MOS 63B

Equipment Condition

Paragraph Condition Description

Vehicle parked on level surface, engine off, and parking brake applied.

Materials/Parts

- Cleaning solvent Item 1, Appendix C
- Cleaning clothes Item 2, Appendix C
- Electrical tape Item 37, Appendix C
- Wire connector FSCM 9015 PN 9003404

KEY

- 1. Screws (2)
- 2. Retainer
- 3. Lens
- 4. Lamp
- 5. Wire connector
- 6. Screws (4)
- 7. Gasket
- 8. Lamp base
- 9. Grommet
- 10. Mounting pad
- 11. Electrical lead (BLK)
- 12. Electrical lead (BLU)

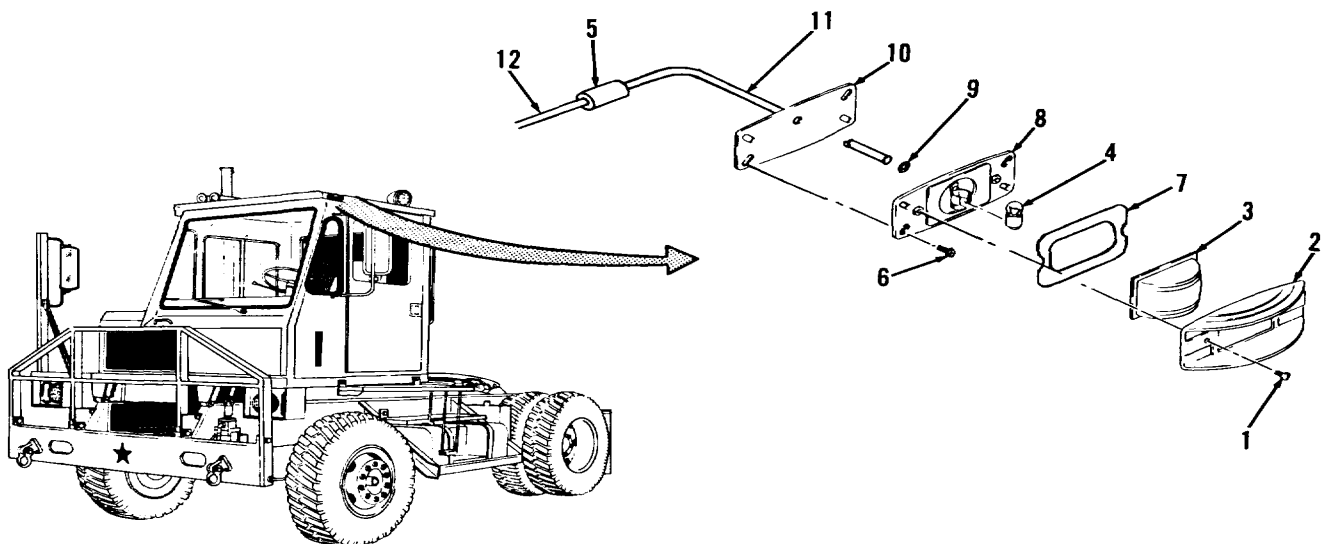

2-31. LIGHT SYSTEMS MAINTENANCE (CONT)

e. Marker Lights (cont).

STEP	LOCATION	ITEM	ACTION	REMARKS
REMOVAL				
1	Cab roof, outside	a. Two screws (1), retainer (2), and lens (3)	Remove	
		b. Retainer (2) and lens (3)	Separate	
		c. Lamp (4)	Remove	
NOTE				
Perform steps 2 and 3 below only if replacement of marker light assembly is required.				
2	Cab roof, inside	a. Upper cab harness tape	Remove	Trace electrical lead (11) into upper cab harness. Remove tape until wire connector (5) is exposed
		b. Wire connector (5)	Remove	Cut wire leads (11 and 12) as close as possible to connector (5)
3	Cab roof, outside	a. Four screws (6)	Remove	
		b. Gasket (7), lamp base (8), grommet (9), mounting pad (10), and electrical lead (11)	Remove	As an assembly
CLEANING				
4		a. Lens (3)	Clean	Rinse lens in clear water; dry with clean, dry cloth

2-31. LIGHT SYSTEMS MAINTENANCE (CONT)

e. Marker Lights (cont).

STEP	LOCATION	ITEM	ACTION	REMARKS
------	----------	------	--------	---------

CLEANING (cont)

WARNING

Dry cleaning solvent (P-D-680), used to clean parts is toxic and flammable. Wear protective goggles and gloves and use only in a well ventilated area. Avoid contact with skin, eyes, and clothes and don't breathe vapors. Do not use near open flame or excessive heat and don't smoke when using it. Failure to do so could cause serious injury. If you become dizzy while using cleaning solvent, get fresh air and medical attention immediately. If contact with skin or clothes is made, flush with large amounts of water. If contact with eyes is made, wash eyes with water and seek medical aid immediately.

Compressed air must not exceed 30 psi. Wear safety glasses when drying parts with compressed air. Failure to do so could cause serious injury to eyes and possible blindness. If you hurt your eyes or if a foreign object is blown into your eyes, seek medical attention immediately.

		b. Screws (1) and retainer (2)	Clean	Use cleaning solvent P-D-680; dry with compressed air or clean cloths
--	--	--------------------------------	-------	---

INSPECTION

5	a.	Lamp (4)	Inspect	Replace if broken or filament broken
	b.	Lamp socket and wiring	Inspect	Replace marker light assembly if broken, or insulation cracked or frayed
	c.	All other parts	Inspect	Replace if cracked, broken, distorted, or threads damaged

INSTALLATION

NOTE

Perform steps 6 and 7 below only if marker light assembly was removed.

2-31. LIGHT SYSTEMS MAINTENANCE (CONT)

e. Marker Lights (cont).

STEP	LOCATION	ITEM	ACTION	REMARKS
INSTALLATION (cont)				
6	Cab roof, outside	a. Mounting pad (10)	Position	On cab roof
		b. Electrical lead (11)	Install	Thru hole in mounting pad and cab roof
		c. Grommet (9) and lamp base (8)	Position	On mounting pad (10)
		d. Four screws (6)	Install and tighten	
7	Cab roof, inside	a. Electrical leads (11 and 12)	Strip	For new wire connector (5) insulation
		b. New wire connector (5)	Install	Crimp on leads (11 and 12)
		c. Upper cab harness tape	Install	As required
8	Cab roof, outside	a. Lamp (4)	Install	In lamp socket
		b. Gasket (7)	Position	On lamp base (8), if removed
		c. Retainer (2)	Position	Over lens (3)
		d. Lens (3) and retainer (2)	Position	On lamp base (8)
		e. Two screws (1)	Install and tighten	

2-31. LIGHT SYSTEMS MAINTENANCE (CONT)

f. Trailer Lighting Cables.

This task covers: a. Removal c. Inspection
 b. Cleaning d. Installation

INITIAL SETUP

Tools

No. 2 Common Organizational Maintenance

Tool Kit

- Safety glasses
- Automotive electrical tool kit
- Multimeter

Personnel Required

Wheel Vehicle Mechanic MOS 63B

Equipment Condition

Paragraph	Condition Description
2-65j	Vehicle parked on level surface, engine off, and parking brake applied. Rear window guard open.

Materials/Parts

- | | |
|-------------------|---------------------|
| Cleaning solvent | Item 1, Appendix C |
| Clean cloths | Item 2, Appendix C |
| Detergent | Item 27, Appendix C |
| Denatured alcohol | Item 30, Appendix C |

KEY

1. Trailer connector plugs (2)
2. 12 Volt cable
3. Locknuts (2)
4. Capscrews (2)
5. Washers (4)
6. Plug holder
7. 24 Volt cable

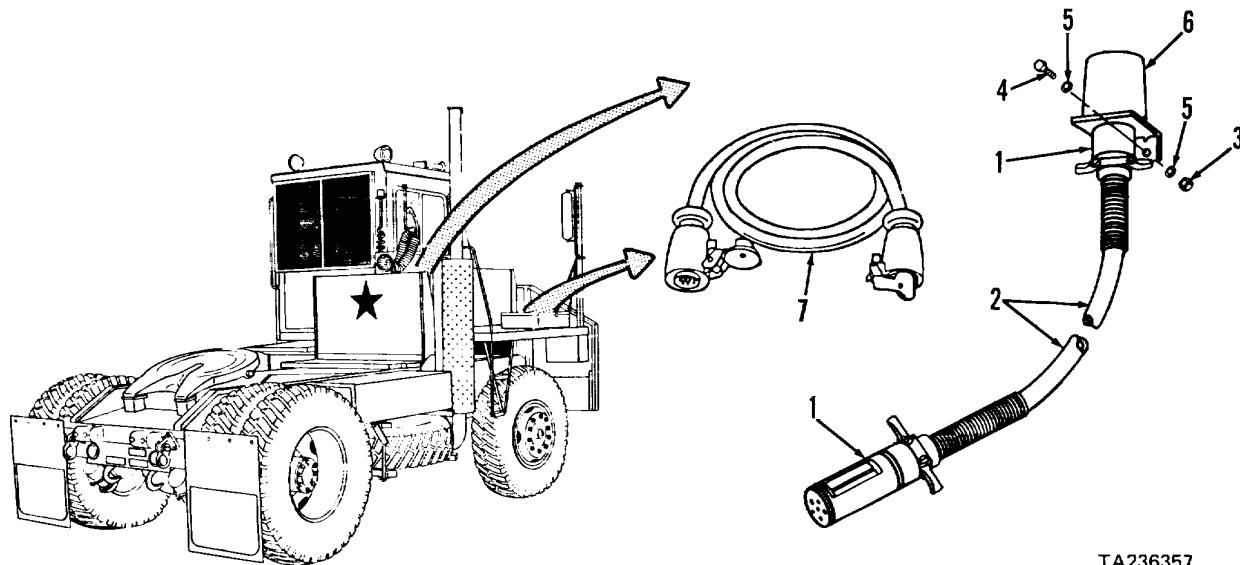

TA236357

2-31. LIGHT SYSTEMS MAINTENANCE (CONT)

f. Trailer Lighting Cables (cont).

STEP	LOCATION	ITEM	ACTION	REMARKS
REMOVAL				
1	Rear hood enclosure	Trailer connector plug (1)	Unplug	From receptacle
2	Rear window guard	a. Trailer connector plug (1)	Unplug	From plug holder (6)
		b. Cable (2)	Remove	Support plug holder (6)
		c. Two locknuts (3), cap-screws (4), and four washers (5)	Remove	
		d. Plug holder (6)	Remove	
CLEANING				
3		a. Trailer connector plugs (1) electrical connectors	Clean	Wipe with clean cloth moistened with denatured alcohol
		b. Cables (2 and 7) Clean		Wipe with cloth moistened with mild detergent solution; rinse with clear water. Dry thoroughly with clean cloths

WARNING

Dry cleaning solvent (P-D-680), used to clean parts is toxic and flammable. Wear protective goggles and gloves and use only in a well ventilated area. Avoid contact with skin, eyes, and clothes and don't breathe vapors. Do not use near open flame or excessive heat and don't smoke when using it. Failure to do so could cause serious injury. If you become dizzy while using cleaning solvent, get fresh air and medical attention immediately. If contact with skin or clothes is made, flush with large amounts of water. If contact with eyes is made, wash eyes with water and seek medical aid immediately.

2-31. LIGHT SYSTEMS MAINTENANCE (CONT)

f. Trailer Lighting Cables (cont).

STEP	LOCATION	ITEM	ACTION	REMARKS
------	----------	------	--------	---------

CLEANING (cont)

WARNING

Compressed air must not exceed 30 psi. Wear safety glasses when drying parts with compressed air. Failure to do so could cause serious injury to eyes and possible blindness. If you hurt your eyes or if a foreign object is blown into your eyes, seek medical attention immediately.

		c. All other metal parts	Clean	Use cleaning solvent P-D-680; dry thoroughly with compressed air or clean cloths
--	--	--------------------------	-------	--

INSPECTION

4		a. Trailer connector plugs (1)	Check continuity	Use ohmmeter to check continuity between corresponding terminals. Replace a defective plug
		b. Cables (2 and 7)	Inspect	Replace if cracked, broken, jacket deteriorated, or otherwise damaged
		c. Plug holder (6)	Inspect	Replace if cracked, broken, or otherwise damaged
		d. All other parts	Inspect	Replace if cracked, broken, distorted, or threads damaged

INSTALLATION

5	Rear hood enclosure	a. Cables (2 and 7)	Install	Insert one trailer connector plug (1) into 12 Volt receptacle; push one cable (7) plug into 24 Volt receptacle
		b. Cables (2 and 7)	Check voltage	Use voltmeter or test lamp to check for proper light circuit voltage at open end end of each cable; 12 Volts for cable (2), 24 Volts for cable (7)

2-31. LIGHT SYSTEMS MAINTENANCE (CONT)

f. Trailer Lighting Cables (cont).

STEP	LOCATION	ITEM	ACTION	REMARKS
INSTALLATION (cont)				
6	Rear window guard	a. Plug holder (6) b. Four washers (5), two capscrews (4), and locknuts (3) c. Trailer connector plug (1)	Position Install and tighten Install	 Push into plug holder (6) to protect from the elements
7	Cab rear	Rear window guard	Close	Para 2-65j

2-335

2-31. LIGHT SYSTEMS MAINTENANCE (CONT)

g. Flood Lights.

This task covers: a. Removal c. Inspection
 b. Cleaning d. Installation

INITIAL SETUP

Tools

No. 1 Common Organizational Maintenance

Tool Kit

- Socket wrench set
- Screwdriver
- Socket wrench handle
- Tool kit, electrical connector
- Crimping tool
- Wire stripper

Personnel Required

Two Wheel Vehicle Mechanics MOS 63B

Equipment Condition

Paragraph Condition Description

Vehicle parked on level surface, engine off, and parking brake applied.

Materials/Parts

- Cleaning solvent Item 1, Appendix C
- Clean cloths Item 2, Appendix C
- Detergent Item 27, Appendix C
- Adhesive Item 40, Appendix C

STEP	LOCATION	ITEM	ACTION	REMARKS
------	----------	------	--------	---------

REMOVAL (ROOF FLOOD LIGHTS)

1	Tractor cab roof	a. Capscrew (1)	Remove	
		b. Ring (2)	Remove	
		c. Connector (3)	Disconnect	From sealed beam (4)
		d. Sealed beam (4)	Remove	
		e. Gasket (5) and spacer (6)	Remove	

NOTE

Perform following steps only if bracket (14) requires replacement.

f. Capscrew (7), nut (8), and lock washer (9)	Remove	
g. Housing (10)	Remove	From bracket (14) and place on cab roof
h. Nut (11) and lock washer (12)	Remove	From inside of cab

2-31. LIGHT SYSTEMS MAINTENANCE (CONT)

g. Flood Lights (cont).

KEY

- 1. Capscrew
- 2. Ring
- 3. Connector
- 4. Sealed beam
- 5. Gaslet
- 6. Spacer
- 7. Capscrew
- 8. Nut
- 9. Lock washer
- 10. Housing
- 11. Nut
- 12. Lock washer
- 13. Capscrew
- 14. Bracket
- 15. Crimp connector
- 16. Wire lead
- 17. Wire lead
- 18. Loom
- 19. Grommet
- 20. Screws (4)
- 21. Lens
- 22. Bulb
- 23. Capscrews
- 24. Nuts (4)
- 25. Lock washers (4)
- 26. Housing
- 27. Gasket
- 28. Connector
- 29. Terminal

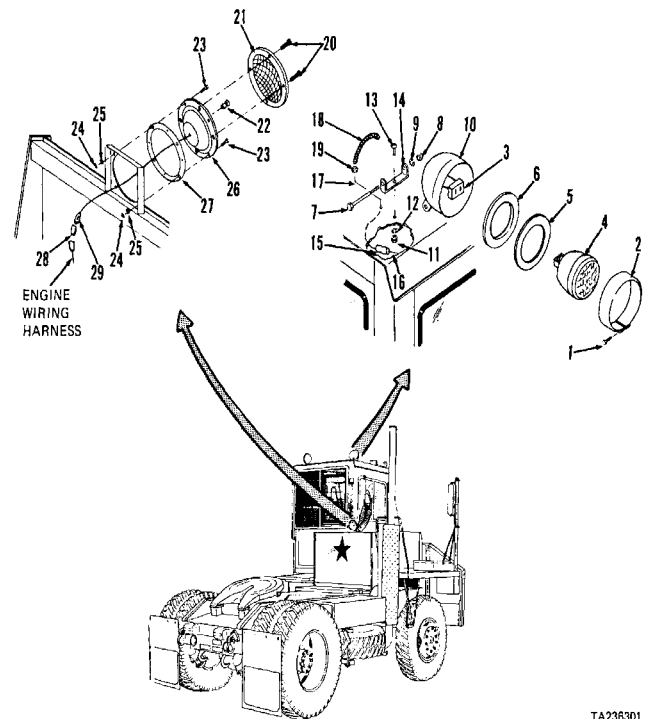

TA236301

2-31. LIGHT SYSTEMS MAINTENANCE (CONT)

g. Flood Lights (cont).

STEP	LOCATION	ITEM	ACTION	REMARKS
REMOVAL (ROOF FLOOD LIGHTS) (CONT)				
1 (cont)		i. Capscrew (13) and bracket (14)	Remove	Note position of bracket (14) for installation

NOTE

Perform following steps only if housing (10) requires replacement.

CAUTION

Head liner is glued in place. When performing following step be careful not to damage head liner when pulling it back to gain access to wire leads.

2	Cab interior	a. Head liner	Carefully remove	Start at corners and care- fully pull head liner back until flood light wire leads are accessible
		b. Crimp connector (15)	Remove and discard	
		c. Wire lead (17)	Pull through grommet (19)	From wire lead (17) If necessary
		d. Loom (18)	Remove	
		e. Grommet (19)	Remove	
		f. Housing (10) with connec- tor (3)	Remove	

REMOVAL (REAR FLOOD LIGHT)

3	Rear cab guard	a. Four screws (20)	Remove
		b. Lens (21)	Remove
		c. Bulb (22)	Remove

NOTE

Perform following steps only if housing (26) requires replacement.

2-31. LIGHT SYSTEMS MAINTENANCE (CONT)

g. Flood Lights (cont).

STEP	LOCATION	ITEM	ACTION	REMARKS
REMOVAL (REAR FLOOD LIGHT) (cont)				
3 (cont)		d. Four capscrews (23), nuts (24), and lock washers (25)	Remove	Support housing (26)
		e. Housing (26)	Support	
		f. Connector (28)	Unplug	From engine wiring harness
		g. Housing (26)	Remove	
		h. Gasket (27)	Remove	
		i. Connector (28)	Remove	From terminal (29) only if terminal (29) or housing (26) requires replacement
	j. Terminal (29)	Remove	Only if damaged	
CLEANING				
4		a. Lens (21)	Clean	Use clean cloth moistened with mild detergent; then rinse in clean water and dry using clean cloth

WARNING

Dry cleaning solvent (P-D-680), used to clean parts is toxic and flammable. Wear protective goggles and gloves and use only in a well ventilated area. Avoid contact with skin, eyes, and clothes and don't breathe vapors. Do not use near open flame or excessive heat and don't smoke when using it. Failure to do so could cause serious injury. If you become dizzy while using cleaning solvent, get fresh air and medical attention immediately. If contact with skin or clothes is made, flush with large amounts of water. If contact with eyes is made, wash eyes with water and seek medical aid immediately.

b. Remaining metallic parts	Clean	Use cleaning solvent P-D-680; dry using clean cloths
-----------------------------	-------	--

2-31. LIGHT SYSTEMS MAINTENANCE (CONT) I

g. Flood Lights (cont).

STEP	LOCATION	ITEM	ACTION	REMARKS
INSPECTION				
5		a. Lens (21)	Inspect for: cracks breaks chips	Replace if defects observed
		b. Housings (10 and 26), ring (2), spacer (6), and bracket (14)	Inspect for: cracks dents breaks bent condition	Replace if defects observed
		c. Connector (3)	Inspect for: cracks broken phenolic loose or corroded terminals	Replace flood light as an assembly if defects are observed
		d. Gasket (5)	Inspect for: tears rips missing material	Replace if defects observed
		e. Remaining parts	Inspect for: cracks breaks deformation damaged threads	Replace if defects observed
INSTALLATION (REAR FLOOD LIGHT)				
6	Rear cab guard	a. Terminal (29) b. Connector (28) c. Gasket (27) d. Housing (26) e. Four capscrews (23), lock washers (25), and nuts (24) f. Bulb (22) g. Lens (21)	Install a. Install b. Connect Position Position Install and tighten Install Position	If removed On terminal (29), if removed To engine wiring harness

2-31. LIGHT SYSTEMS MAINTENANCE (CONT)

g. Flood Lights (cont).

STEP	LOCATION	ITEM	ACTION	REMARKS
INSTALLATION (REAR FLOOD LIGHT) (cont)				
6 (cont)			CAUTION	
			In following step, don't overtighten screws; to do so will cause damage to lens (21).	
		h. Four screws (20)	Install and tighten	
INSTALLATION (ROOF FLOOD LIGHTS)				
7	Tractor cab roof	a. Grommet (19) b. Loom (18) c. Wire lead (17) and loom (18) d. Bracket (14) e. Capscrew (13), lock washer (12) and nut (11) f. Housing (10) g. Capscrew (7), lock washer (9), and nut (8) h. Spacer (6) and gasket (5) i. Connector (3) j. Sealed beam (4) k. Ring (2) l. Capscrew (1)	Install Install Route Position Install and Position Install and tighten Position Connect Install Install Install and tighten	If necessary On wire lead (17) Through grommet (19) On cab roof as noted during removal tighten On bracket (14) To sealed beam (4)
8	Cab interior	a. Wire leads (16 and 17) b. Crimp connector (15) c. Head liner	Strip insulation 3/8 inch from ends of wire leads Install on wire leads then crimp securely Glue	 Into position

NOTE

Place flood light switches in ON positions and check that flood lights operate properly.

2-32. SENDING UNITS AND SWITCHES MAINTENANCE

- a. Oil Pressure Sender and Oil Pressure Sensor.

This task covers:

- a. Removal
- b. Cleaning
- c. Inspection
- d. Installation

INITIAL SETUP

Tools

No. 1 Common Organizational Maintenance

Tool Kit

- Safety glasses
- Screwdriver
- Combination wrench set
- Adjustable open end wrench

Materials/Parts

Cleaning solvent

Clean cloths

Tags

- Item 1, Appendix C
- Item 2, Appendix C
- Item 14, Appendix C

Personnel Required

Wheel Vehicle Mechanic MOS 63B

Equipment Condition

Paragraph

Condition Description

Parked on level surface; parking brake applied; engine off.

KEY

- 1. Nut
- 2. Lock washer
- 3. Electrical lead
- 4. Oil pressure sender
- 5. Screw
- 6. Lock washer
- 7. Electrical lead
- 8. Oil pressure sensor

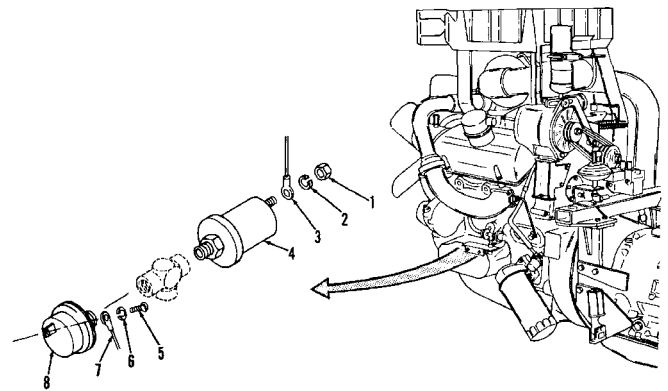

TA236355

2-32. SENDING UNITS AND SWITCHES MAINTENANCE (CONT)

- a. Oil Pressure Sender and Oil Pressure Sensor (cont).

STEP	LOCATION	ITEM	ACTION	REMARKS
------	----------	------	--------	---------

REMOVAL

NOTE

Tag and identify all electrical leads before disconnecting and removing.

1	Engine, left side	a. Electrical leads (3 and 7)	Tag	
		b. Nut (1) and lock washer (2)	Remove	
		c. Electrical lead (3)	Disconnect	
		d. Oil pressure sender (4)	Remove	
		e. Screw (5) and lock washer (6)	Remove	
		f. Electrical lead (7)	Disconnect	
		g. Oil pressure sensor (8)	Remove	

CLEANING

2		a. Electrical leads (3 and 7), oil pressure sender (4), and oil pressure sensor (8)	Clean	Wipe with clean dry cloth only
---	--	---	-------	--------------------------------

WARNING

Dry cleaning solvent (P-D-680), used to clean parts is toxic and flammable. Wear protective goggles and gloves and use only in a well ventilated area. Avoid contact with skin, eyes, and clothes and don't breathe vapors. Do not use near open flame or excessive heat and don't smoke when using it. Failure to do so could cause serious injury. If you become dizzy while using cleaning solvent, get fresh air and medical attention immediately. If contact with skin or clothes is made, flush with large amounts of water. If contact with eyes is made, wash eyes with water and seek medical aid immediately.

2-32. SENDING UNITS AND SWITCHES MAINTENANCE (CONT)

- a. Oil Pressure Sender and Oil Pressure Sensor (cont).

STEP	LOCATION	ITEM	ACTION	REMARKS
CLEANING (cont)				
2 (cont)			WARNING	
		Compressed air must not exceed 30 psi. Wear safety glasses when drying parts with compressed air. Failure to do so could cause serious injury to eyes and possible blindness. If you hurt your eyes or if a foreign object is blown into your eyes, seek medical attention immediately.		
		b. All other parts	Clean	Use cleaning solvent P-D-680; dry with compressed air
INSPECTION				
3		a. Electrical leads (3 and 7)	Inspect	Replace if insulation frayed or connectors damaged
		b. Oil pressure sender (4) and oil pressure sensor (8)	Inspect	Replace if cracked, broken, threads damaged, or defective
		c. All other parts	Inspect	Replace if cracked, broken, distorted, or threads damaged
INSTALLATION				
4	Engine, left side	a. Oil pressure sensor (8)	Install	
		b. Electrical lead (7)	Connect	
		c. Screw (5) and lock washer (6)	Install and tighten	
		d. Oil pressure sender (4)	Install	
		e. Electrical lead (3)	Connect	
		f. Lock washer (2) and nut (1)	Install and tighten	

2-32. SENDING UNITS AND SWITCHES MAINTENANCE (CONT)

b. Fuel Level Sender.

This task covers:

- a. Removal
- b. Cleaning
- c. Inspection
- d. Adjustment
- e. Installation

INITIAL SETUP

Tools

No. 1 Common Organizational Maintenance Tool Kit
Automotive electrical tool kit
Safety glasses

Personnel Required

Wheel Vehicle Mechanic MOS 63B

Equipment Condition

Paragraph Condition Description

Materials/Parts

Cleaning solvent Item 1, Appendix C
Clean cloths Item 2, Appendix C
Fine sandpaper Item 4, Appendix C
Tags Item 14, Appendix C
Gasket FSCM 98440 PN 2013

2-13b(l) Vehicle parked on level surface, engine off, and parking brake applied.
Fuel tank platform removed.

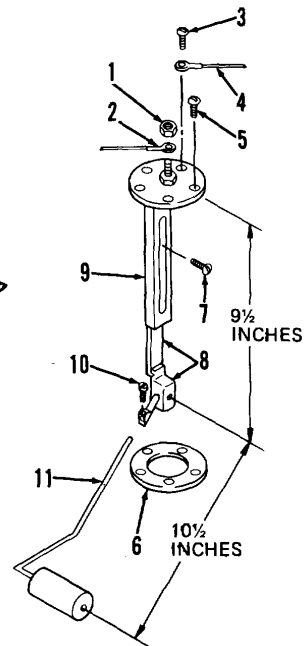
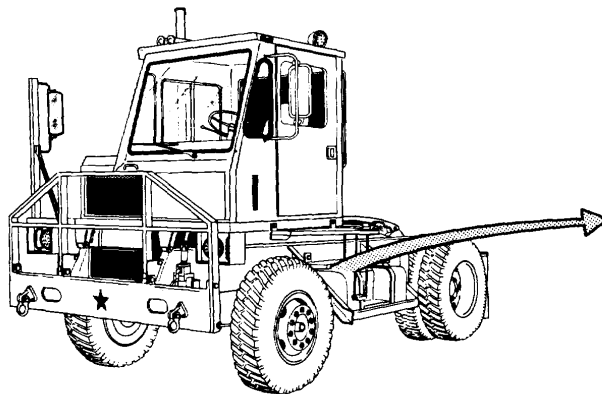

TA236308

KEY

- 1. Nut
- 2. Electrical lead (YEL/BLK)
- 3. Screw
- 4. Electrical lead (WHT)
- 5. Screws (4)
- 6. Gasket
- 7. Screw
- 8. Sender head
- 9. Bracket
- 10. Screw
- 11. Float arm

2-32. SENDING UNITS AND SWITCHES MAINTENANCE (CONT)

b. Fuel Level Sender (cont).

STEP	LOCATION	ITEM	ACTION	REMARKS
------	----------	------	--------	---------

REMOVAL

WARNING

Diesel fuel is highly combustible. Do not smoke or allow open flames or sparks into the area. Death or severe injury may result if personnel fail to observe this precaution. If you are burned, obtain medical aid immediately.

NOTE

Tag and identify electrical leads before disconnecting and removing.

1	Tractor, left side, fuel tank	a. Two electrical leads (2 and 4)	Tag	
		b. Nut (1) and electrical lead (2)	Remove	From fuel level sender terminal
		c. Screw (3) and electrical lead (4)	Remove	
		d. Four screws (5)	Remove	
		e. Fuel level sender assembly	Remove	Lift from fuel tank
		f. Gasket (6)	Remove and discard	

CLEANING

2		a. Fuel level sender assembly	Clean	Wipe with clean cloth moistened with clean diesel fuel. Dry thoroughly with clean cloths
---	--	-------------------------------	-------	--

2-32. SENDING UNITS AND SWITCHES MAINTENANCE (CONT) |

b. Fuel Level Sender (cont).

STEP	LOCATION	ITEM	ACTION	REMARKS
------	----------	------	--------	---------

CLEANING (cont)

WARNING

Dry cleaning solvent (P-D-680), used to clean parts is toxic and flammable. Wear protective goggles and gloves and use only in a well ventilated area. Avoid contact with skin, eyes, and clothes and don't breathe vapors. Do not use near open flame or excessive heat and don't smoke when using it. Failure to do so could cause serious injury. If you become dizzy while using cleaning solvent, get fresh air and medical attention immediately. If contact with skin or clothes is made, flush with large amounts of water. If contact with eyes is made, wash eyes with water and seek medical aid immediately. Compressed air must not exceed 30 psi. Wear safety glasses when drying parts with compressed air. Failure to do so could cause serious injury to eyes and possible blindness. If you hurt your eyes or if a foreign object is blown into your eyes, seek medical attention immediately.

		b. Electrical leads (2 and 4) connectors and terminals	Clean	Use cleaning solvent P-D-680 on connectors and terminals only. Dry with clean cloths. Polish corroded terminals to brightness with fine sandpaper
		c. All other parts	Clean	Use cleaning solvent P-D-680; dry with compressed air or clean cloths

INSPECTION

3		a. Electrical leads (2 and 4)	Inspect	Replace if connectors broken, cracked, or missing, or insulation cracked or frayed
		b. Fuel level sender assembly	Inspect	Replace if cracked, broken, distorted, or terminal damaged
		c. All other parts	Inspect	Replace if cracked, broken, or threads damaged

2-32. SENDING UNITS AND SWITCHES MAINTENANCE (CONT)

b. Fuel Level Sender (cont).

ADJUSTMENT

NOTE

Perform step 4 below only if necessary to install new fuel level sender assembly.

4	New fuel level sender	a. Screw (7)	Remove	Support sender head (8)
		b. Sender head (8)	Rotate	Turn sender head 180 degrees, pointing stub of float arm (11) toward bracket (9)
		c. Screw (7)	Install	Do not tighten
		d. Sender head (8) and bracket (9)	Adjust	Adjust distance from mounting plate to sender head (8) pivot point to 9-1/2 inches
		e. Screw (7)	Tighten	
		f. Screw (10)	Loosen	
		g. Sender head (8) and float arm (11)	Adjust	Adjust distance from sender head (8) pivot point to opposite end of float arm (11) to 10-1/2 inches
		h. Screw (10)	Tighten	
		i. Float arm (11)	Cut	Cut and discard excess length of float arm

INSTALLATION

5	Tractor, left side, fuel tank	a. New gasket (6)	Position	On fuel tank
		b. Fuel level sender assembly	Install	In fuel tank
		c. Four screws (5)	Install	Do not tighten
		d. Electrical lead (4) and screw (3)	Install	
		e. Screws (3 and 5) Tighten alternately		
		f. Electrical lead (2)	Connect	To fuel level sender terminal
		g. Nut (1)	Install and tighten	
		h. Fuel tank platform	Install	Para 2-13b(1)

2-32. SENDING UNITS AND SWITCHES MAINTENANCE (CONT)

c. Water Temperature Sender and Alarmstat.

This task covers:

- a. Removal
- b. Cleaning

- c. Inspection
- d. Installation

INITIAL SETUP

Tools

- No. 1 Common Organizational Maintenance Tool Kit
- Safety glasses
- Combination wrench set
- Adjustable open end wrench

Personnel Required

Wheel Vehicle Mechanic MOS 63B

Equipment Condition

Paragraph	Condition Description
2-15a(l)	Parked on level surface; parking brake applied; engine off. Cab tilted 45 degrees. Engine coolant drained below level of thermostats.

Materials/Parts

- | | |
|------------------|---------------------|
| Cleaning solvent | Item 1, Appendix C |
| Clean cloths | Item 2, Appendix C |
| Tags | Item 14, Appendix C |

2-15a(l)

Parked on level surface; parking brake applied; engine off. Cab tilted 45 degrees. Engine coolant drained below level of thermostats.

KEY

- 1. Nut
- 2. Lock washer
- 3. Electrical lead (VIO)
- 4. Alarmstat sensor
- 5. Nut
- 6. Lock washer
- 7. Electrical lead (LT GRN/BLK)
- 8. Water temperature sender

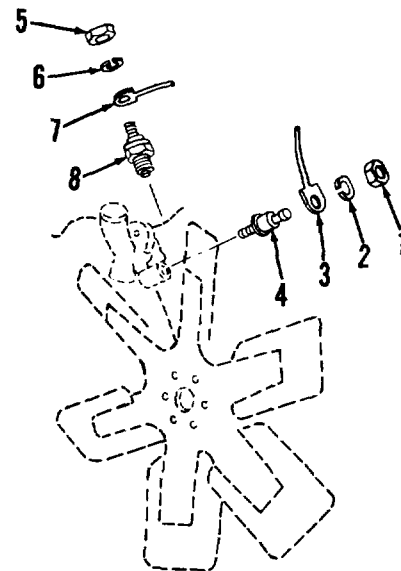
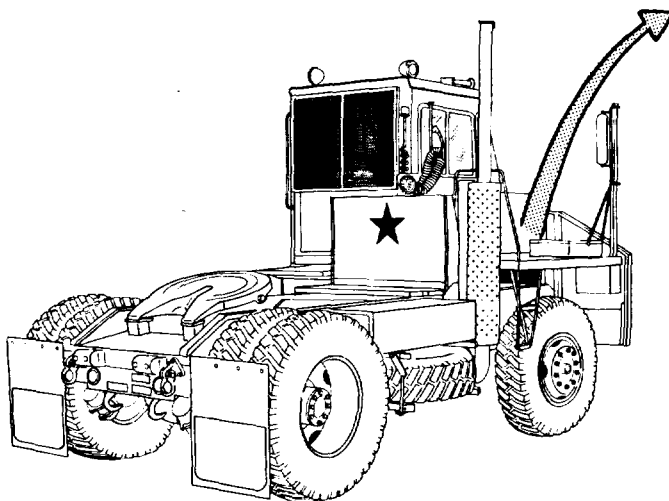

TA236356

2-32. SENDING UNITS AND SWITCHES MAINTENANCE (CONT)

c. Water Temperature Sender and Alarmstat (cont).

STEP	LOCATION	ITEM	ACTION	REMARKS
------	----------	------	--------	---------

REMOVAL

NOTE

Tag and identify electrical leads before disconnecting and removing.

1	Engine, front, right side	a. Electrical leads (3 and 7)	Tag	
		b. Nut (1) and lock washer (2)	Remove	From alarmstat sensor (4)
		c. Electrical lead (3)	Disconnect	
		d. Alarmstat sensor (4)	Remove	
		e. Nut (5) and lock washer (6)	Remove (8)	From water temperature sender
		f. Electrical lead (7)	Disconnect	
		g. Water temperature sender (8)	Remove	

CLEANING

2		a. Electrical leads (3 and 7), alarmstat sensor (4), and water temperature sender (8)	Clean	Wipe with clean dry cloth only
---	--	---	-------	--------------------------------

WARNING

Dry cleaning solvent (P-D-680), used to clean parts is toxic and flammable. Wear protective goggles and gloves and use only in a well ventilated area. Avoid contact with skin, eyes, and clothes and don't breathe vapors. Do not use near open flame or excessive heat and don't smoke when using it. Failure to do so could cause serious injury. If you become dizzy while using cleaning solvent, get fresh air and medical attention immediately. If contact with skin or clothes is made, flush with large amounts of water. If contact with eyes is made, wash eyes with water and seek medical aid immediately.

2-32. SENDING UNITS AND SWITCHES MAINTENANCE (CONT)

- c. Water Temperature Sender and Alarmstat (cont).

STEP	LOCATION	ITEM	ACTION	REMARKS
------	----------	------	--------	---------

CLEANING (cont)**WARNING**

Compressed air must not exceed 30 psi. Wear safety glasses when drying parts with compressed air. Failure to do so could cause serious injury to eyes and possible blindness. If you hurt your eyes or if a foreign object is blown into your eyes, seek medical attention immediately.

b. All other parts	Clean	Use cleaning solvent P-D-680; dry with compressed air
--------------------	-------	---

INSPECTION

3	a. Electrical leads (3 and 7)	Inspect	Replace if insulation frayed or connectors damaged
	b. Alarmstat sensor (4) and water temperature sender (8)	Inspect	Replace if cracked, broken, threads damaged, or defective
	c. All other parts	Inspect	Replace if cracked, broken, distorted, or threads damaged

INSTALLATION

4	Engine, front right side	a. Water temperature sender (8)	Install	
		b. Electrical lead (7)	Connect	
		c. Nut (5) and lock washer (6)	Install and tighten	
		d. Alarmstat sensor (4)	Install	
		e. Electrical lead (3)	Connect	
		f. Lock washer (2) and nut (1)	Install and tighten	
5	Radiator, top	Coolant	Add	Para 2-15a(l)

2-32. SENDING UNITS AND SWITCHES MAINTENANCE (CONT)

d. Transmission Temperature Sender.

This task covers:

- a. Removal
- b. Cleaning

- c. Inspection
- d. Installation

INITIAL SETUP

Tools

No. 1 Common Organizational Maintenance
Tool Kit
Automotive electrical tool kit

Equipment Condition

Paragraph	Condition Description
	Parked on level surface; parking brake applied; engine off.
2-65c	Rear platform removed.

Materials/Parts

Clean cloths Item 2, Appendix C

Personnel Required

Wheel Vehicle Mechanic MOS 63B

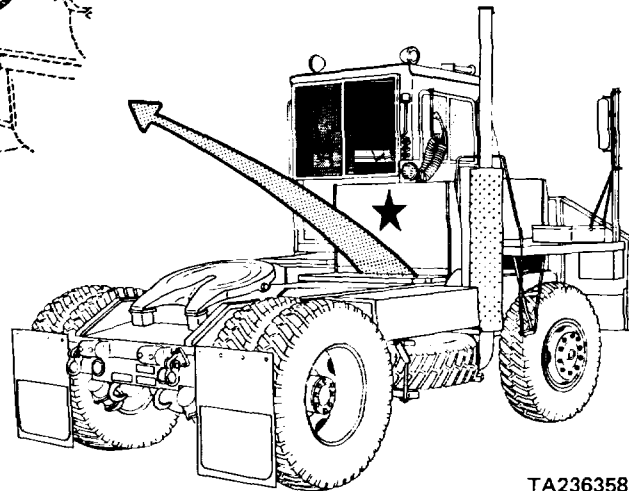
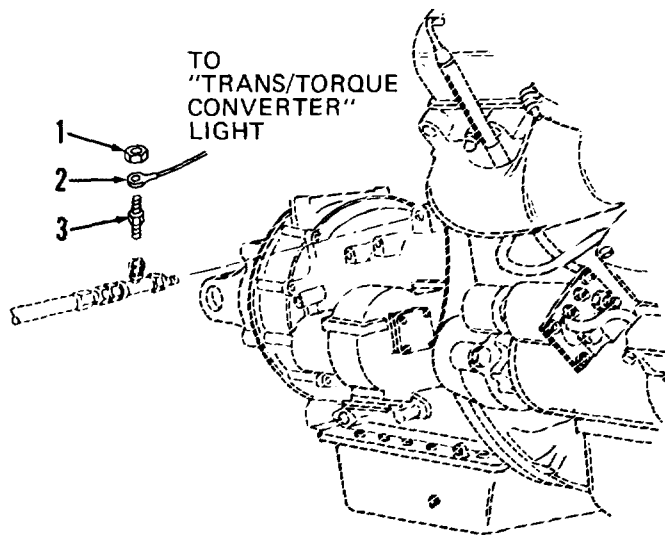

Key

- 1. Nut
- 2. Electrical lead
- 3. Transmission temperature sender

2-32. SENDING UNITS AND SWITCHES MAINTENANCE (CONT)
--

d. Transmission Temperature Sender (cont).

STEP	LOCATION	ITEM	ACTION	REMARKS
REMOVAL				
1	Transmission, right side, top	a. Nut (1) b. Electrical lead (2) c. Transmission temperature sender (3)	Remove Disconnect Remove	
CLEANING				
2	All parts	Clean	Wipe with clean, dry cloth	
INSPECTION				
3		a. Electrical lead (2) b. Transmission temperature sender (3)	Inspect Inspect	Replace if cracked, broken, insulation frayed, or connector damaged Replace if cracked, broken, defective, or threads damaged
INSTALLATION				
4	Transmission, right side, top	a. Transmission temperature sender (3) b. Electrical lead (2) c. Nut (1)	Install Connect Install and tighten	
5	Behind cab guard	Rear platform	Install	Para 2-65c

2-32. SENDING UNITS AND SWITCHES MAINTENANCE (CONT)

e. Neutral Start and Backup Light Switches.

This task covers:

- a. Removal
- b. Cleaning
- c. Inspection
- d. Installation
- e. Adjustment/Test

INITIAL SETUP

Tools

No. 1 Common Organizational Maintenance

Tool Kit

- Screwdriver
- Socket wrench set
- Torque wrench
- Safety glasses

Tool Kit, Electrical Connector

- Crimping tool
- Wire stripper

Tie strap FSCM 96906 PN MS3667-1-9

Electrical connectors FSCM 77060 PN 2965867

Personnel Required

Wheel Vehicle Mechanic MOS 63B

Equipment Condition

Paragraph Condition Description

Materials/Parts

Cleaning

solvent

Item 1, Appendix C

Clean cloths

Item 2, Appendix C

Tags

Item 14, Appendix C

Grease

Item 26, Appendix C

Vehicle parked on level surface, engine off, and parking brake applied. Key switch off and key removed. Cab tilted 45 degrees.

STEP	LOCATION	ITEM	ACTION	REMARKS
------	----------	------	--------	---------

REMOVAL

1	Cab, under hood	a. Connector housing (1)	Disconnect	Unplug from wiring harness connector
		b. Two screws (2) and locknuts (3)	Remove	From shift quadrant plate. Support backup light switch (4)
		c. Backup light switch (4)	Remove	
		d. Two screws (5) and locknuts (6)	Remove	From shift quadrant plate. Support neutral start switch (7)
		e. Neutral start switch (7)	Remove	
		f. Tie strap (8) and discard	Cut, remove	Note location for installation

NOTE

Tag and identify all electrical leads before disconnecting and removing.

2-32. SENDING UNITS AND SWITCHES MAINTENANCE (CONT)

e. Neutral Start and Backup Light Switches (cont).

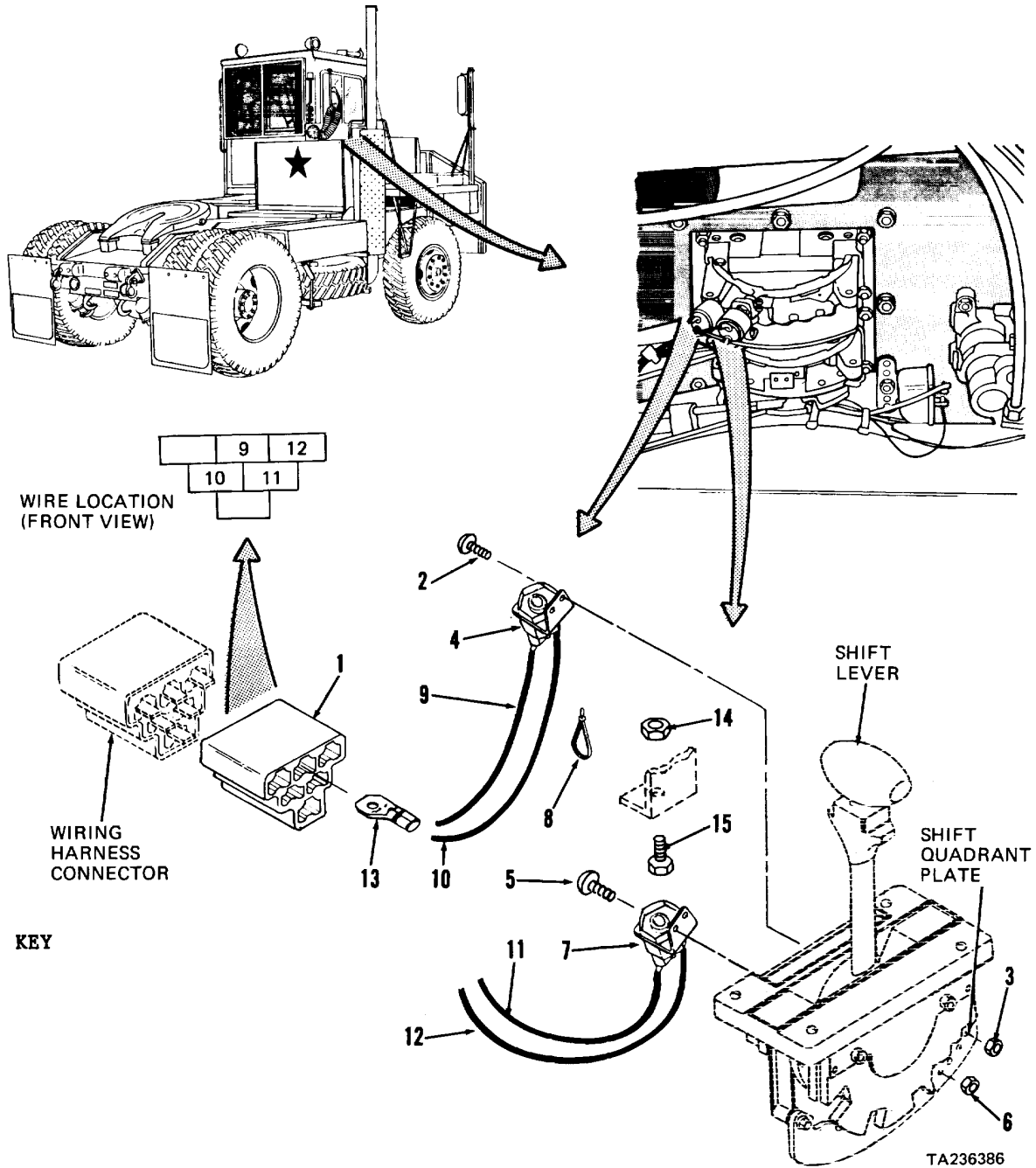

- | | |
|---------------------------|-------------------------------|
| 1. Connector housing | 11. Electrical lead (BLK) |
| 2. Screws (2) | 12. Electrical lead (BLK) |
| 3. Locknuts (2) | 13. Electrical connectors (4) |
| 4. Backup light switch | 14. Nut |
| 5. Screws (2) | 15. Lock screw |
| 6. Locknuts (2) | |
| 7. Neutral start switch | |
| 8. Tie strap | |
| 9. Electrical lead (BLK) | |
| 10. Electrical lead (BLK) | |

2-32. SENDING UNITS AND SWITCHES MAINTENANCE (CONT)

e. Neutral Start and Backup Light Switches (cont).

STEP	LOCATION	ITEM	ACTION	REMARKS
REMOVAL (cont)				
1 (cont)		g. Four electrical leads (9 thru 12)	Tag and disconnect	Pull electrical connectors (13) with leads from connector housing (1)
		h. Four electrical connectors (13)	Remove and discard	Only if inspection indicates need for replacement. Cut lead as close to connector as possible
CLEANING				
2		a. Electrical leads (9 thru 12), backup light switch (4), neutral start switch (7), and connector housing (1)	Clean	Wipe with clean, dry cloth
<u>WARNING</u>				
Dry cleaning solvent (P-D-680), used to clean parts is toxic and flammable. Wear protective goggles and gloves and use only in a well ventilated area. Avoid contact with skin, eyes, and clothes and don't breathe vapors. Do not use near open flame or excessive heat and don't smoke when using it. Failure to do so could cause serious injury. If you become dizzy while using cleaning solvent, get fresh air and medical attention immediately. If contact with skin or clothes is made, flush with large amounts of water. If contact with eyes is made, wash eyes with water and seek medical aid immediately. Compressed air must not exceed 30 psi. Wear safety glasses when drying parts with compressed air. Failure to do so could cause serious injury to eyes and possible blindness. If you hurt your eyes or if a foreign object is blown into your eyes, seek medical attention immediately.				
		b. All other parts	Clean	Use cleaning solvent P-D-680; dry with compressed air or clean cloths

2-32. SENDING UNITS AND SWITCHES MAINTENANCE (CONT)
--

e. Neutral Start and Backup Light Switches (cont).

STEP	LOCATION	ITEM	ACTION	REMARKS
INSPECTION				
3		a. Electrical leads (9 thru 12)	Inspect	Replace if insulation frayed, cut, or cracked or if conductor corroded or broken
		b. Backup light switch (4) and neutral start switch (7)	Inspect	Replace if cracked, broken, or inoperative
		c. All other parts	Inspect	Replace if cracked, broken, distorted, or threads damaged
INSTALLATION				
4	Cab, under hood	a. Four new electrical connectors (13)	a. Install, if necessary b. Connect	Strip 1/2-inch insulation from lead; crimp securely Push connectors with leads into connector housing (1) as tagged
		b. Neutral start switch (7)	Position	On shift quadrant plate; align mounting holes
		c. Two screws (5) and locknuts (6)	Install and tighten	
		d. Backup light switch (4)	Position	On shift quadrant plate; align mounting holes
		e. Two screws (2) and locknuts (3)	Install and tighten	
		f. Connector housing (1)	Connect	Plug into wiring harness connector
		g. New tie strap (8)	Install	At location noted during removal

ADJUSTMENT/TEST**NOTE**

Neutral start switch should prevent use of engine starter unless shift lever is in neutral (N) position. If starter will crank with shift lever in any other position, adjust neutral start switch as follows.

2-32. SENDING UNITS AND SWITCHES MAINTENANCE (CONT)

e. Neutral Start and Backup Light Switches (cont).

STEP	LOCATION	ITEM	ACTION	REMARKS
ADJUSTMENT/TEST (cont)				
5		a. Shift lever	Position	In drive position 2
		b. Nut (14)	Remove	
		c. Lock screw (15)	a. Remove	Apply thin coat of grease to threads
			b. Install	
		d. Nut (14)	Install	Do not tighten
		e. Lock screw (15)	Adjust	Adjust lock screw (2) so that screw depresses ball on neutral start switch 1/8 inch when shift lever is in neutral (N) position
		f. Neutral start switch (7)	Test	Check that neutral start switch actuates in neutral (N) position only, and that switch opens within 3-1/2 degrees of angular travel from bottomed position of shift lever
		g. Nut (14)	Tighten	To 33 pounds inch torque
6		Backup light switch (4)	Test	Check that rear floodlight is on with engine idling and shift lever in reverse (R) position

2-32. SENDING UNITS AND SWITCHES MAINTENANCE (CONT)

f. Stop Light Switches.

(1) Service Brakes Stop Light Switch.

This task covers: a. Removal c. Inspection
b. Cleaning d. Installation

INITIAL SETUP

Tools

No. 1 Common Organizational Maintenance
Tool Kit
Combination wrench set
Safety glasses

Materials/Parts

Cleaning solvent	Item 1, Appendix C
Clean cloths	Item 2, Appendix C
Teflon tape	Item 43, Appendix C

Personnel Required

Wheel Vehicle Mechanic MOS 63B

Equipment Condition

Paragraph	Condition Description
	Vehicle parked on level surface, engine off, and parking brake applied. Cab tilted 45 degrees.
2-41h(l)	All air pressure relieved.
2-34a	Battery ground cable disconnected.
2-65d	Heat shield removed.

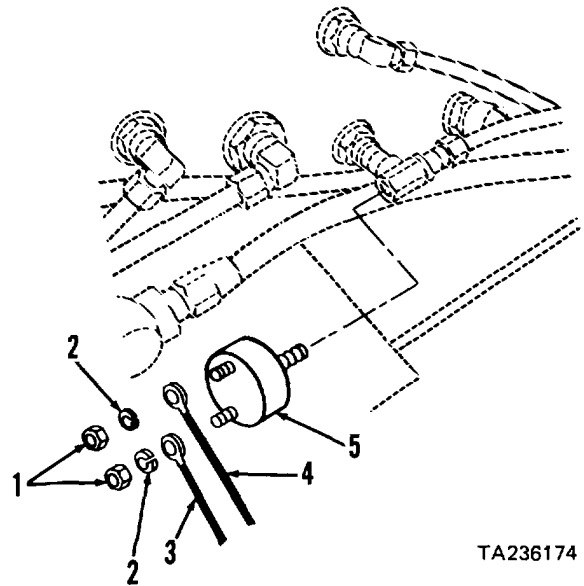
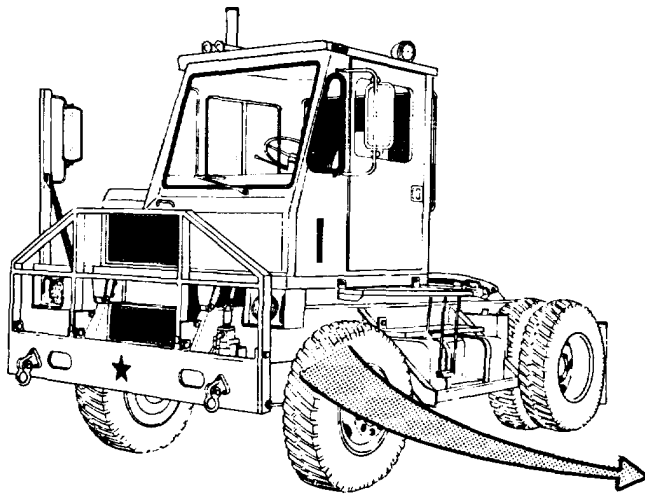

TA236174

KEY

1. Nuts (2)
2. Lock washers (2)
3. Electrical lead (GRN/WHT)
4. Electrical lead (ORG/GRN)
5. Stop light switch

2-32. SENDING UNITS AND SWITCHES MAINTENANCE (CONT) |

f. Stop Light Switches (cont).

(1) Service Brakes Stop Light Switch (cont).

STEP	LOCATION	ITEM	ACTION	REMARKS
REMOVAL				
NOTE				
Tag and identify all electrical leads before disconnection and removal.				
1	Left hand frame rail, inside	a. Two electrical leads (3 and 4)	Tag	
		b. Two nuts (1) and lock washers (2)	Remove	
		c. Two electrical leads (3 and 4)	Disconnect	
		d. Stop light switch (5)	Remove	Rotate counterclockwise

CLEANING

2		a. Two electrical leads (3 and 4) and stop light switch (5)	Clean	Wipe with clean, dry cloth
---	--	---	-------	----------------------------

WARNING

Dry cleaning solvent (P-D-680), used to clean parts is toxic and flammable. Wear protective goggles and gloves and use only in a well ventilated area. Avoid contact with skin, eyes, and clothes and don't breathe vapors. Do not use near open flame or excessive heat and don't smoke when using it. Failure to do so could cause serious injury. If you become dizzy while using cleaning solvent, get fresh air and medical attention immediately. If contact with skin or clothes is made, flush with large amounts of water. If contact with eyes is made, wash eyes with water and seek medical aid immediately. Compressed air must not exceed 30 psi. Wear safety glasses when drying parts with compressed air. Failure to do so could cause serious injury to eyes and possible blindness. If you hurt your eyes or if a foreign object is blown into your eyes, seek medical attention immediately.

2-32. SENDING UNITS AND SWITCHES MAINTENANCE (CONT) I

f. Stop Light Switches (cont).

(1) Service Brakes Stop Light Switch (cont).

STEP	LOCATION	ITEM	ACTION	REMARKS
CLEANING (cont)				
2 (cont)		b. All other parts	Clean	Use cleaning solvent P-D-680; dry thoroughly with compressed air or clean cloths
INSPECTION				
3		a. Two electrical leads (3 and 4)	Inspect	Replace if insulation frayed or if leads cracked, broken, or terminals damaged
		b. Stop light switch (5)	Inspect	Replace if cracked, broken, connectors or threads damaged, or defective
		c. All other parts	Inspect	Replace if cracked, broken, or threads damaged
INSTALLATION				
4	Left hand frame rail, inside	a. Stop light switch (5)	a. Tape	Wrap threads with Teflon tape Rotate clockwise to tighten
		b. Two electrical leads (3 and 4)	b. Install Connect	
		c. Two lock washers (2) and nuts (1)	Install and tighten	
		d. Heat shield	Install	Para 2-65d
5	Cab tilt pump	Cab	Lower	To normal operating position
6	Battery box	Battery ground cable	Connect	Para 2-34a
7	Tractor	Air pressure	Restore	Para 2-41h(l)

2-32. SENDING UNITS AND SWITCHES MAINTENANCE (CONT)

- f. Stop Light Switches (cont).

 - (2) Trailer Hand Brake Stop Light Switch.

This task covers: a. Removal c. Inspection
 b. Cleaning d. Installation

INITIAL SETUP

Tools

No. 1 Common Organizational Maintenance Tool Kit

Combination wrench set
 Safety glasses

Materials/Parts

Cleaning solvent Item 1, Appendix C
 Clean cloths Item 2, Appendix C
 Teflon tape Item 43, Appendix C

Equipment Condition

Paragraph	Condition Description
	Vehicle parked on level surface, engine off, and parking brake applied.
	All air pressure relieved.
2-41h(l) 2-34a	Battery ground cable disconnected.

Personnel Required

Wheel Vehicle Mechanic MOS 63B

STEP	LOCATION	ITEM	ACTION	REMARKS
------	----------	------	--------	---------

REMOVAL

NOTE

Tag and identify all electrical leads before disconnection and removal.

1	Cab interior, right side	a. Two electrical leads (3 and 4)	Tag	
		b. Two nuts (1) and lock washers (2)	Remove	
		c. Two electrical leads (3 and 4)	Disconnect	
		d. Stop light switch (5)	Remove	Rotate counterclockwise

2-32. SENDING UNITS AND SWITCHES MAINTENANCE (CONT)

- f. Stop Light Switches (cont).
- (2) Trailer Hand Brake Stop Light Switch (cont).

KEY

- 1. Nuts (2)
- 2. Lock washers (2)
- 3. Electrical lead (GRN)
- 4. Electrical lead (ORG)
- 5. Stop light switch

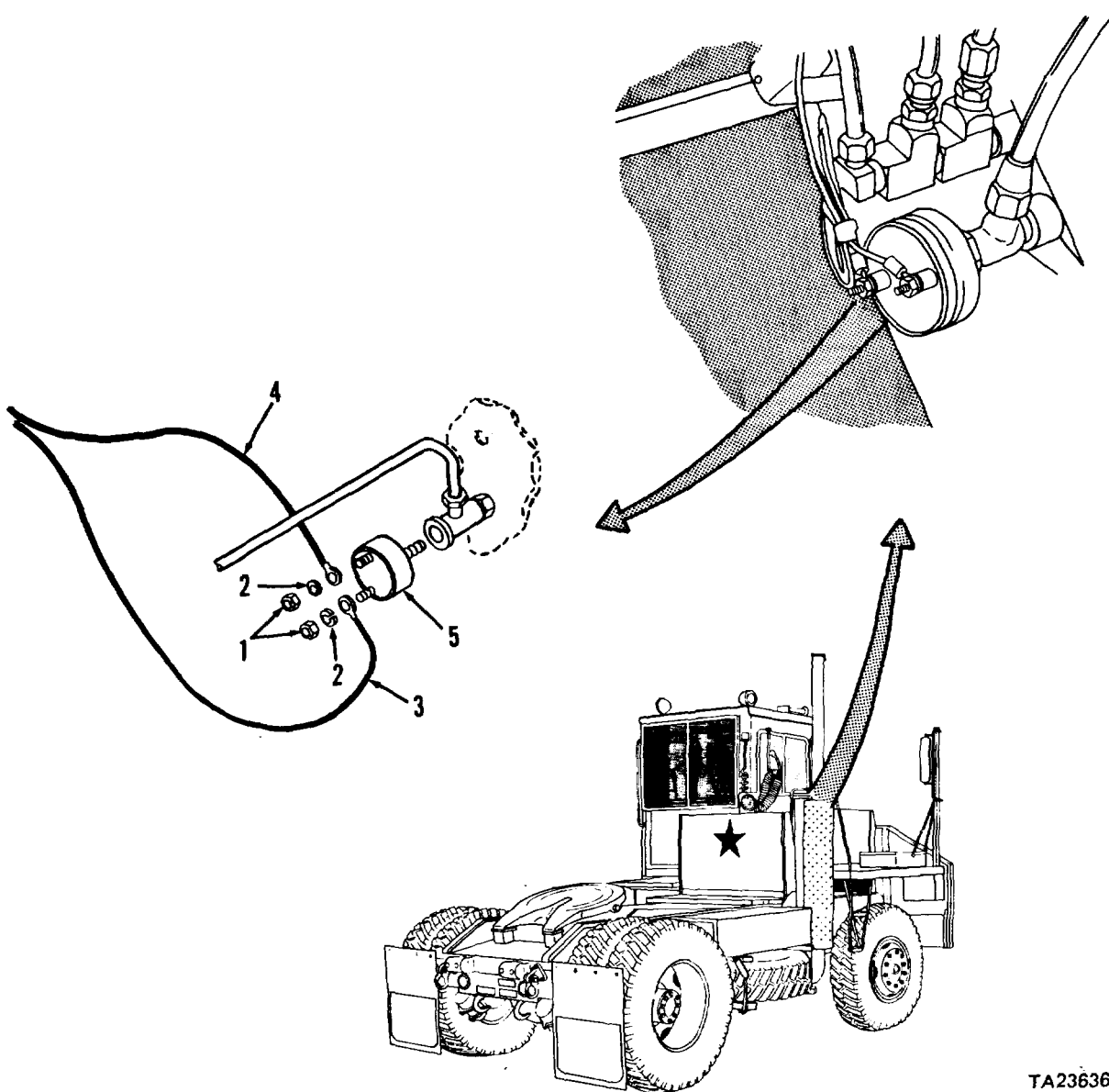

TA236360

2-32. SENDING UNITS AND SWITCHES MAINTENANCE (CONT)

- f. Stop Light Switches (cont).
- (2) Trailer Hand Brake Stop Light Switch (cont).

STEP	LOCATION	ITEM	ACTION	REMARKS
------	----------	------	--------	---------

CLEANING

2		a. Two electrical leads (3 and 4) and stop light switch (5)	Clean	Wipe with clean, dry cloth
---	--	---	-------	----------------------------

WARNING

Dry cleaning solvent (P-D-680), used to clean parts is toxic and flammable. Wear protective goggles and gloves and use only in a well ventilated area. Avoid contact with skin, eyes, and clothes and don't breathe vapors. Do not use near open flame or excessive heat and don't smoke when using it. Failure to do so could cause serious injury. If you become dizzy while using cleaning solvent, get fresh air and medical attention immediately. If contact with skin or clothes is made, flush with large amounts of water. If contact with eyes is made, wash eyes with water and seek medical aid immediately. Compressed air must not exceed 30 psi. Wear safety glasses when drying parts with compressed air. Failure to do so could cause serious injury to eyes and possible blindness. If you hurt your eyes or if a foreign object is blown into your eyes, seek medical attention immediately.

		b. All other parts	Clean	Use cleaning solvent P-D-680; dry thoroughly with compressed air or clean cloths
--	--	--------------------	-------	--

INSPECTION

3		a. Two electrical leads (3 and 4)	Inspect	Replace if insulation frayed or if leads cracked, broken, or terminals damaged
		b. Stop light switch (5)	Inspect	Replace if cracked, broken, connectors or threads damaged, or defective
		c. All other parts	Inspect	Replace if cracked, broken, or threads damaged

2-32. SENDING UNITS AND SWITCHES MAINTENANCE (CONT)

f. Stop Light Switches (cont).

(2) Trailer Hand Brake Stop Light Switch (cont).

STEP	LOCATION	ITEM	ACTION	REMARKS
INSTALLATION				
4	Cab interior, right side	a. Stop light switch (5) b. Two electrical leads (3 and 4) c. Two lock washers (2) and nuts (1)	a. Tape b. Install Connect Install and tighten	Wrap threads with Teflon tape Rotate clockwise to tighten
5	Battery box	Battery ground cable	Connect	Para 2-34a
6	Tractor	Air pressure	Restore	Para 2-41h(1)

2-33. HORN SYSTEM MAINTENANCE

a. Horn and Relay.

- This task covers:
- a. Removal
 - b. Cleaning
 - c. Inspection
 - d. Adjustment
 - e. Installation

INITIAL SETUP

Tools

No. 1 Common Organizational Maintenance
Tool Kit

- Socket wrench set
- Socket wrench handle
- Rheostat
- Voltmeter
- Ammeter

Personnel Required

Wheel Vehicle Mechanic MOS 63B

Equipment Condition

Paragraph Condition Description

Vehicle parked on level surface, engine off, and parking brake applied.

2-34a Battery ground cable disconnected.

Materials/Parts

- Cleaning solvent Item 1, Appendix C
- Clean cloths Item 2, Appendix C
- Fine sandpaper Item 4, Appendix C
- Tags Item 14, Appendix C

STEP	LOCATION	ITEM	ACTION	REMARKS
------	----------	------	--------	---------

REMOVAL

NOTE

Tag and identify all electrical leads before disconnecting and removing.

1	Right hand frame rail, front	a. Three electrical leads (5 thru 7)	Tag	
		b. Nut (1) and lock washer (2)	Remove	Pull relay (8) from bracket (11) stud and support
		c. Three screws (3) and lock washers (4)	Loosen	Do not remove
		d. Three electrical leads (5 thru 7)	Disconnect	From relay (8)
		e. Relay (8)	Remove	
		f. Nut (9) and lock washer (10)	Remove	Support bracket (11)
		g. Bracket (11)	Remove	

2-33. HORN SYSTEM MAINTENANCE

a. Horn and Relay (cont).

KEY

- 1. Nut
- 2. Lock washer
- 3. Screws (3)
- 4. Lock washers (3)
- 5. Electrical lead (BLU)
- 6. Electrical lead (ORG/BLK)
- 7. Electrical lead (GRN/ORG)
- 8. Relay
- 9. Nut
- 10. Lock washer
- 11. Bracket
- 12. Capscrew
- 13. Nut
- 14. Lock washer
- 15. Nut
- 16. Bracket
- 17. Horn

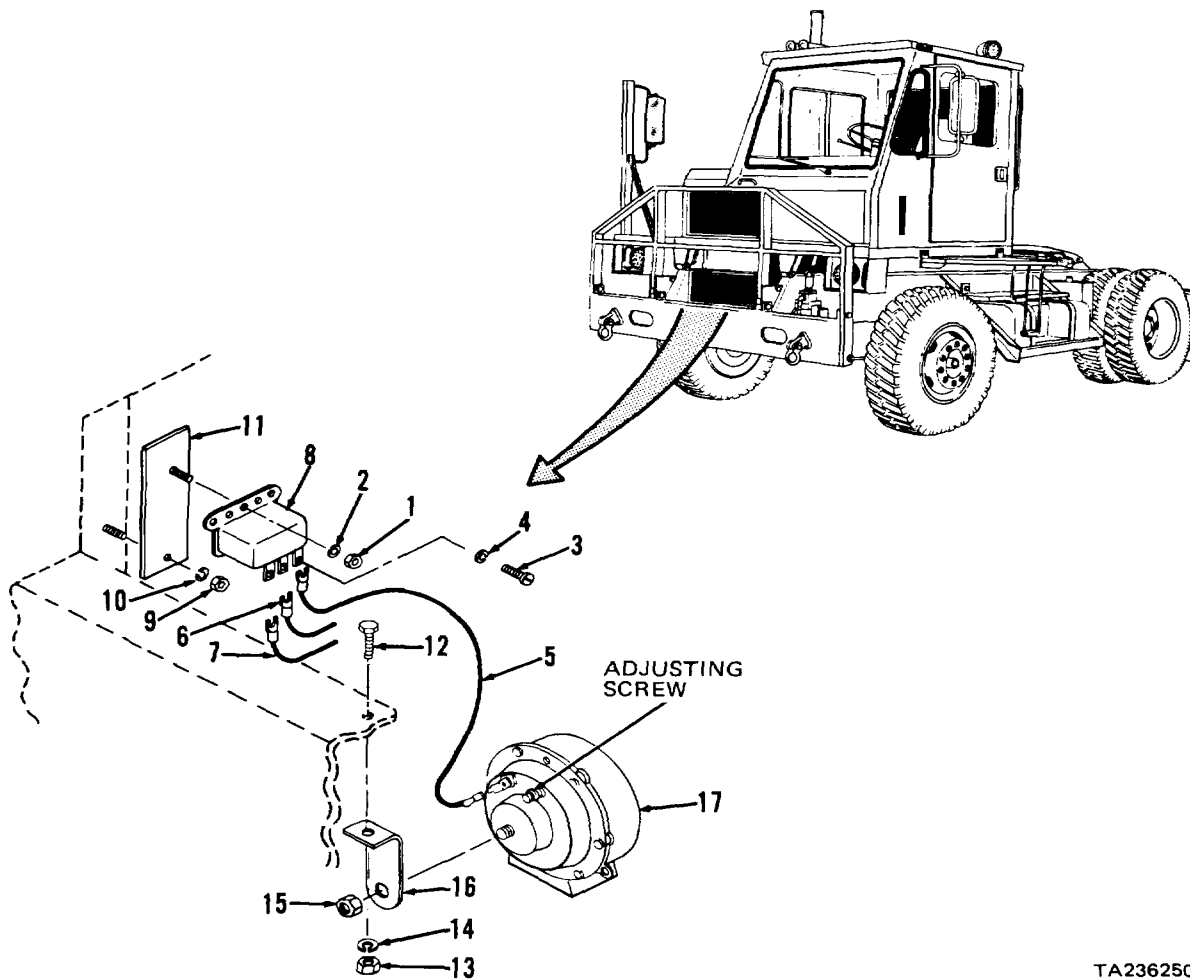

TA236250

2-33. HORN SYSTEM MAINTENANCE

a. Horn and Relay (cont).

STEP	LOCATION	ITEM	ACTION	REMARKS
REMOVAL (cont)				
2	Front frame crossmember	a. Electrical lead (5)	Disconnect and remove	Unplug from horn (17)
		b. Capscrew (12), nut (13), lock washer (14)	Remove and	Support horn and bracket assembly
		c. Nut (15) and bracket (16)	Remove	From horn (17)

CLEANING

3		a. Electrical leads (5 thru 7) and relay (8)	Clean	Wipe with clean, dry cloth
---	--	--	-------	----------------------------

WARNING

Dry cleaning solvent (P-D-680), used to clean parts is toxic and flammable. Wear protective goggles and gloves and use only in a well ventilated area. Avoid contact with skin, eyes, and clothes and don't breathe vapors. Do not use near open flame or excessive heat and don't smoke when using it. Failure to do so could cause serious injury. If you become dizzy while using cleaning solvent, get fresh air and medical attention immediately. If contact with skin or clothes is made, flush with large amounts of water. If contact with eyes is made, wash eyes with water and seek medical aid immediately.

		b. Horn (17)	Clean	Wipe exterior with clean cloth moistened with cleaning solvent P-D-680; dry with clean cloth
		c. All other metal parts	Clean	Use cleaning solvent P-D-680; dry with clean cloths

2-33. HORN SYSTEM MAINTENANCE

a. Horn and Relay (cont).

STEP	LOCATION	ITEM	ACTION	REMARKS
INSPECTION				
4		a. Electrical leads (5 thru 7) and horn (17)	Inspect	Replace if cracked, broken, frayed, defective, or otherwise damaged. Polish corroded terminals to brightness with fine sandpaper
		b. Relay (8)	Inspect	Replace if cracked, broken, defective, or terminals damaged
		c. All other parts	Inspect	Replace if cracked, broken, distorted, or threads damaged
ADJUSTMENT				
5		a. Horn (17)	Connect	Connect horn to adjustment circuit as shown. Adjust rheostat for 12.4 Vdc indication on voltmeter

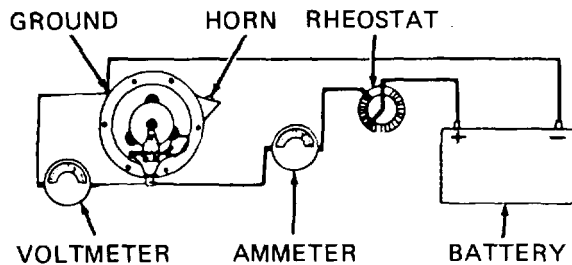

TA236251

NOTE

Do not stuff rags or other material in horn throat to muffle sound while adjusting. This changes vibration frequency and results in a false current setting.

b. Adjusting screw	Turn	Turn adjusting screw 1/10 turn at a time, until ammeter indicates 4.5 amperes. Turn adjusting screw counterclockwise to increase current, clockwise to decrease current; then disconnect horn from test circuit
--------------------	------	---

2-33. HORN SYSTEM MAINTENANCE

a. Horn and Relay (cont).

STEP	LOCATION	ITEM	ACTION	REMARKS
INSTALLATION				
6	Horn (17)	a. Bracket (16) b. Nut (15)	Position Install and tighten	On horn (17)
7	Front frame crossmember	a. Bracket (16) with horn (17) b. Capscrew (12), lock washer (14), (13) c. Electrical lead (5)	Position Install and and nut Connect	On crossmember tighten Push onto horn (17)
8	Right hand frame rail, front	a. Bracket (11) b. Lock washer (10) and nut (9)	Position Install and	On right hand frame rail stud tighten
9	Relay (8)	a. Three electri- cal leads (5 thru 7) b. Three screws (3)	Connect Tighten	To relay (8). Blue lead (5) to H, orange/black lead (6) to B, and green/orange lead (7) to S. Support relay Support relay (8)
10	Right hand frame rail, front	a. Relay (8) b. Lock washer (2) and nut (1)	Position Install and tighten	On bracket (11) stud
11	Battery box	Battery ground cable	Connect	Para 2-34a
12	Tractor cab	Horn and relay	Test	Check proper operation by turning key switch on and depressing horn push button

2-33. HORN SYSTEM MAINTENANCE

b. Horn Switch.

This task covers:

- a. Removal
- b. Cleaning
- c. Inspection
- d. Installation

INITIAL SETUP

Tools

- No. 1 Common Organizational Maintenance Tool Kit
- Wrench set
- Safety glasses
- Screwdriver set

Equipment Condition

Paragraph Condition Description

Vehicle parked on level surface, engine off, and parking brake applied. Steering column connector disconnected.

Materials/Parts

- Cleaning solvent Item 1, Appendix C
- Clean cloths Item 2, Appendix C

Personnel Required

Wheel Vehicle Mechanic MOS 63B

KEY

- 1. Horn button
- 2. Spring seat
- 3. Spring
- 4. Screw
- 5. Screws (2)
- 6. Retainer
- 7. Rivets (3)
- 8. Posts (3)
- 9. Contact ring
- 10. Screws (2)
- 11. Emblem
- 12. Contact
- 13. Spring
- 14. Contact seat

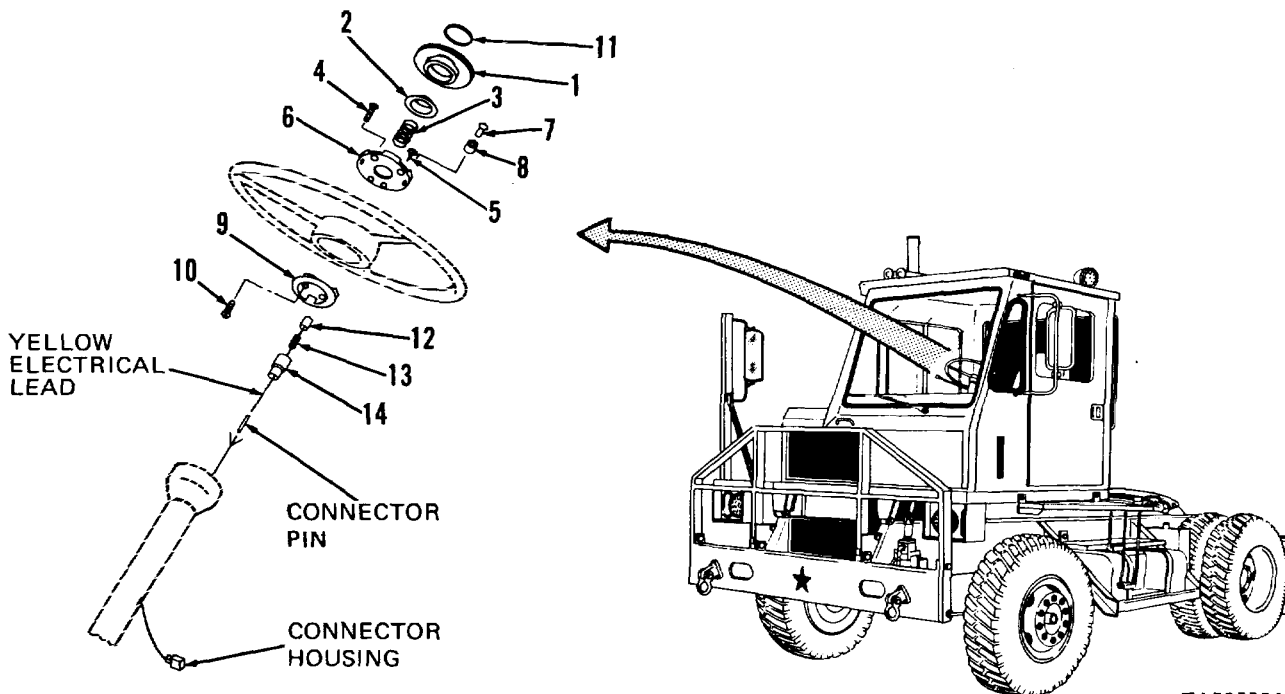

TA236304

2-33. HORN SYSTEM MAINTENANCE

b. Horn Switch (cont).

STEP	LOCATION	ITEM	ACTION	REMARKS
------	----------	------	--------	---------

REMOVAL

1	Tractor cab, inside	a. Horn button (1) rotate	Depress and button unlocks	Rotate counterclockwise until
		b. Horn button (1), seat (2), and spring (3)	Remove spring	
		c. Screw (4), two screws (5), and retainer (6)	Remove	

NOTE

Do not remove rivets (7) and posts (8); if inspection indicates that posts (8) are damaged the horn button assembly will require replacement.

d. Steering wheel	Remove	Para 2-58a
e. Contact ring (9) and two screws (10)	Remove	
f. Emblem (11)	Remove if necessary	Use sharp edge tool to lift three tabs on bottom side of horn button (1); then remove

NOTE

Perform steps lg and lh below only if testing or inspection indicates need for replacement of contact assembly (12 thru 14).

g. Yellow electrical lead with connector pin	a. Tag b. Unplug	From connector housing
h. Contact assembly (12 thru 14)	Remove	Carefully pull from steering column as an assembly

2-33. HORN SYSTEM MAINTENANCE

b. Horn Switch (cont).

STEP	LOCATION	ITEM	ACTION	REMARKS
CLEANING				
2		a. Horn button (1)	Clean	Wipe with clean, dry cloth

WARNING

Dry cleaning solvent (P-D-680), used to clean parts is toxic and flammable. Wear protective goggles and gloves and use only in a well ventilated area. Avoid contact with skin, eyes, and clothes and don't breathe vapors. Do not use near open flame or excessive heat and don't smoke when using it. Failure to do so could cause serious injury. If you become dizzy while using cleaning solvent, get fresh air and medical attention immediately. If contact with skin or clothes is made, flush with large amounts of water. If contact with eyes is made, wash eyes with water and seek medical aid immediately.

Compressed air must not exceed 30 psi. Wear safety glasses when drying parts with compressed air. Failure to do so could cause serious injury to eyes and possible blindness. If you hurt your eyes or if a foreign object is blown into your eyes, seek medical attention immediately.

		b. All other metal parts	Clean	Wipe with clean cloth moistened with cleaning solvent P-D-680; dry with compressed air or clean cloths
--	--	--------------------------	-------	--

INSPECTION

3		a. Contact assembly (12 thru 14)	Inspect	Replace if cracked, broken, pins broken or missing, or otherwise damaged
		b. Horn button (1)	Inspect	Replace if cracked or broken
		c. Spring seat (2) and retainer (6)	Inspect	Replace if cracked, broken, or distorted
		d. Springs (3 and 13)	Inspect	Replace if cracked or permanently set
		e. All other parts	Inspect	Replace if cracked, broken, or threads damaged

2-33. HORN SYSTEM MAINTENANCE

b. Horn Switch (cont).

STEP	LOCATION	ITEM	ACTION	REMARKS
INSTALLATION				
4	Tractor cab, inside	a. Contact assembly (12 thru 14)	Install	In steering column
		b. Connector pin	Install	Press pin into connector housing; as tagged
		c. Contact ring (9) and two screws (10)	Install	Be sure tapered hole in contact ring (9) aligns with hole for screw (4)
		d. Steering wheel	Install	Para 2-58a
		e. Retainer (6), two screws (5), and screw (4)	Install	Install screw (4) through hole in steering wheel as shown below
		f. Spring (3) and spring seat (2)	Install	
		g. Emblem (11)	Install	Insert three tabs in horn button (1) slots and bend tabs over to secure
		h. Horn button (1)	Depress and rotate	Rotate clockwise until button locks
5	Steering column	Connector	Connect	
6	Cab, inside	Horn	Test	Check for proper operation by turning key switch on and depressing horn push button

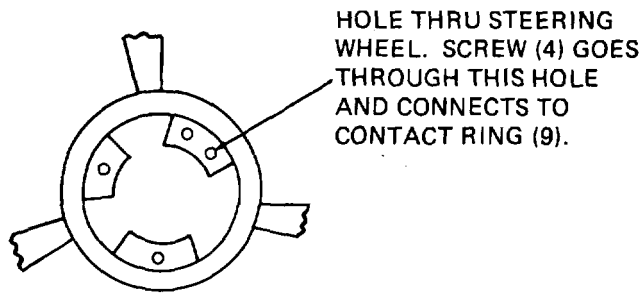

STEERING WHEEL (TOP VIEW)

TA236236

2-34. BATTERY SYSTEM MAINTENANCE

a. Battery Cables and Batteries.

This task covers:

- a. Removal
- b. Cleaning
- c. Inspection
- d. Testing
- e. Installation
- f. Charging

INITIAL SETUP

Tools

No. 1 Common Organizational Maintenance

Tool Kit

- Socket wrench set
- Battery carrier
- Battery terminal lifter
- Battery filler
- Scratch wire brush
- Safety glasses
- Hydrometer
- Torque wrench

Automotive Mechanic's Tool Kit

- Pliers
- Combination wrench set

Soft mallet

Battery charger

Protective gloves

Battery terminal spreader

Five tie straps FSCM 96906 PN MS3667-2-9

Baking soda

Distilled water

Fine wire

Personnel Required

Two Wheel Vehicle Mechanics MOS 63B

Equipment Condition

Paragraph Condition Description

Vehicle parked on level surface, engine off, and parking brake applied. Key switch off and key removed.

Spare tire carrier lowered.

2-34b Battery box lid open.

Materials/Parts

Cleaning

- solvent Item 1, Appendix C
- Clean cloths Item 2, Appendix C
- Engine oil Item 24, Appendix C

STEP	LOCATION	ITEM	ACTION	REMARKS
------	----------	------	--------	---------

REMOVAL

1	Battery box	a. Nut (1) and capscrew (2)	Remove	From negative lug (8)
		b. Negative cable (3)	Disconnect	From negative lug (8)
		c. Nut (1) and capscrew (2)	Remove	From positive lug (9)
		d. Positive cable (4)	Disconnect	From positive lug (9)
		e. Six nuts (1)Remove and capscrews (2)		From positive lugs (9) and negative lugs (8)

2-34. BATTERY SYSTEM MAINTENANCE

a. Battery Cables and Batteries (cont).

KEY

- 1. Nuts (8)
- 2. Capscrews (8)
- 3. Negative cable
- 4. Positive cable
- 5. Battery cables (6)
- 6. Nuts (8)
- 7. Capscrews (8)
- 8. Negative lugs (4)
- 9. Positive lugs (4)
- 10. Locknuts (6)
- 11. Washers (6)
- 12. Capscrews (4)
- 13. Hold-down links (2)
- 14. Hold-down brackets (4)
- 15. Batteries (4)
- 16. Rubber
- 17. Tie straps (2)
- 18. Tie straps (3)

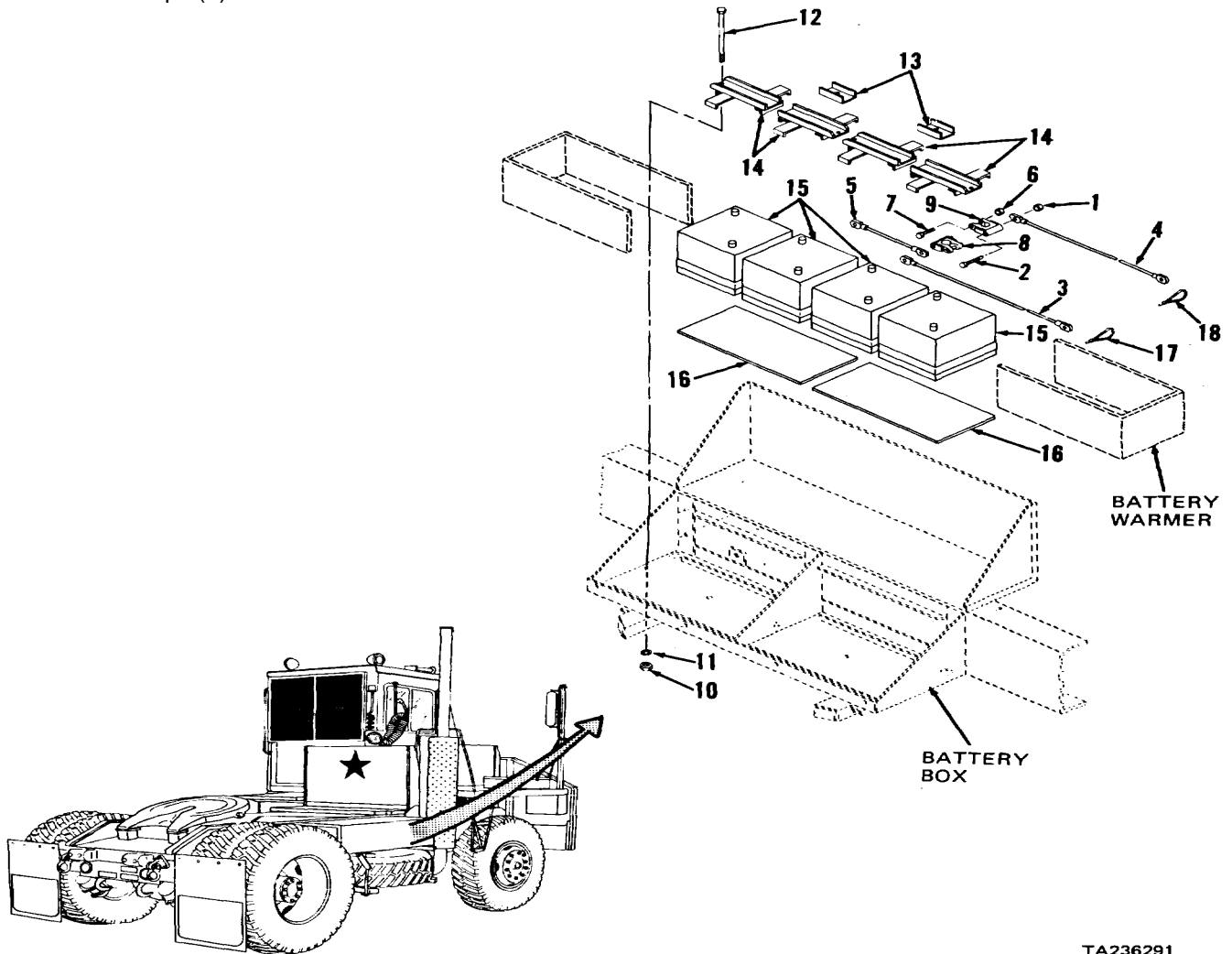

TA236291

2-34. BATTERY SYSTEM MAINTENANCE

a. Battery Cables and Batteries (cont).

STEP	LOCATION	ITEM	ACTION	REMARKS
------	----------	------	--------	---------

REMOVAL (cont)

1		f. Six battery (cont)cables (5)	Disconnect	
		g. Eight nuts (6) and capscrews (7)	Loosen	

CAUTION

Do not pry terminal lugs loose using a screwdriver blade between the lugs and battery case or damage to the battery will result.

		h. Four negative lugs (8)	Remove	Use battery terminal lifter
		i. Four positive lugs (9)	Remove	Use battery terminal lifter
		j. Six locknuts (10), washers (11), and four cap-screws (12)	Remove	
		k. Two hold-down links (13) and four hold-down brackets (14)	Remove	

WARNING

Battery warmers operate from 110 Vac commercial power source. Disconnect winterization cable from receptacle at front bumper of tractor before proceeding. Serious injury or death can result from contact with energized 110 Vac power lines. If you are injured, obtain medical aid immediately.

2	Tractor, front bumper	Winterization system cable	Unplug	If plugged in, para 2-73c
3	Battery box	a. Battery warmers b. Four batteries (15) c. Two rubber pads (16)	Remove Remove Remove	Para 2-73c Use battery carrier or battery carrying handles

2-34. BATTERY SYSTEM MAINTENANCE

a. Battery Cables and Batteries (cont).

STEP	LOCATION	ITEM	ACTION	REMARKS
REMOVAL (cont)				
4	Battery box, underside	a. Two tie straps (17) b. Negative cable (3) and positive cable (4)	Cut, remove, and discard Remove	Note locations to aid installation From underside of battery box
5	Transmission, hand side	Negative cable (3) right	a. Disconnect b. Remove	From transmission, para 2-41j From tractor
6	Starter	a. Positive cable (4) b. Three tie straps (18) c. Positive cable (4)	Disconnect Cut, remove, and discard Remove	From starter, para 2-25b Note locations to aid installation
CLEANING				
7		a. Cables (3, 4, and 5) b. Negative lugs (8) and positive lugs (9) c. Batteries (15) d. Rubber pads (16)	Clean Clean Clean exterior Clean	Wipe cables with clean, dry cloth Use wire brush with baking soda and water paste to remove all traces of corrosion; flush with clear water. Dry with clean cloths; coat with light film of clean engine oil Use paste of baking soda and water. Use care to prevent baking soda paste from entering batteries. Use wire brush on battery posts to remove all traces of corrosion. Flush with clear water Wipe with clean cloth moistened with water. Dry with clean cloths

2-34. BATTERY SYSTEM MAINTENANCE

a. Battery Cables and Batteries (cont).

STEP	LOCATION	ITEM	ACTION	REMARKS
------	----------	------	--------	---------

CLEANING (cont)
7
(cont)

WARNING

Dry cleaning solvent (P-D-680), used to clean parts is toxic and flammable. Wear protective goggles and gloves and use only in a well ventilated area. Avoid contact with skin, eyes, and clothes and don't breathe vapors. Do not use near open flame or excessive heat and don't smoke when using it. Failure to do so could cause serious injury. If you become dizzy while using cleaning solvent, get fresh air and medical attention immediately. If contact with skin or clothes is made, flush with large amounts of water. If contact with eyes is made, wash eyes with water and seek medical aid immediately.

Compressed air must not exceed 30 psi. Wear safety glasses when drying parts with compressed air. Failure to do so could cause serious injury to eyes and possible blindness. If you hurt your eyes or if a foreign object is blown into your eyes, seek medical attention immediately.

e. All metal parts	Clean	Use cleaning solvent P-D-680; dry with compressed air
--------------------	-------	---

INSPECTION

8 a. Batteries (15) Inspect

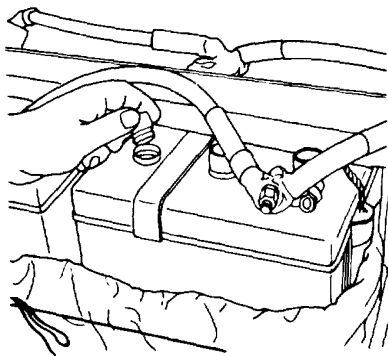

TA236290

Check battery case and cell covers for cracks and breaks. Replace if these conditions are observed. Remove battery cell covers and check vent holes for obstructions. Clear vent hole obstructions with fine wire. Check electrolyte level in each cell. Add distilled water if less than 3/8 inch above plates

b. Cables (3, 4, Inspect and 5)		Replace if cracked, broken, frayed, or lugs damaged
---------------------------------	--	---

2-34. BATTERY SYSTEM MAINTENANCE

a. Battery Cables and Batteries (cont).

STEP	LOCATION	ITEM	ACTION	REMARKS
INSPECTION (cont)				
8 (cont)		c. Rubber pads (16)	Inspect	Replace if cracked, torn, or deteriorated
		d. All other parts	Inspect	Replace if cracked, broken, distorted, or threads damaged

TESTING

WARNING

Battery electrolyte is toxic and corrosive. Use protective goggles and gloves when performing the following. Avoid contact with skin, eyes, clothes, and don't breathe vapors. Failure to follow this procedure could cause severe injury. If you are injured, obtain medical aid immediately.

9	Batteries (15)	a. Vent covers b. Specific	Remove Check	Use hydrometer. Draw sufficient electrolyte into hydrometer to allow float to suspend freely. Note the reading of float at liquid level as shown. Return electrolyte to battery cell by squeezing hydrometer bulb
---	-------------------	-------------------------------	-----------------	---

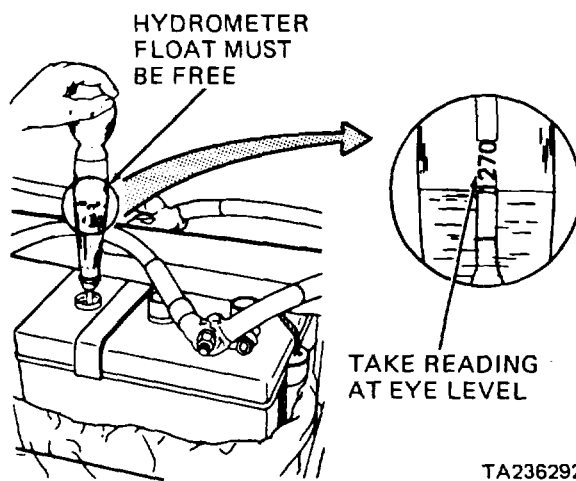

For convenience, hydrometer scale may be marked 1270, 1280, etc., instead of 1.270, 1.280, etc.

2-34. BATTERY SYSTEM MAINTENANCE

a. Battery Cables and Batteries (cont).

STEP	LOCATION	ITEM	ACTION	REMARKS
------	----------	------	--------	---------

TESTING (cont)

9
(cont)

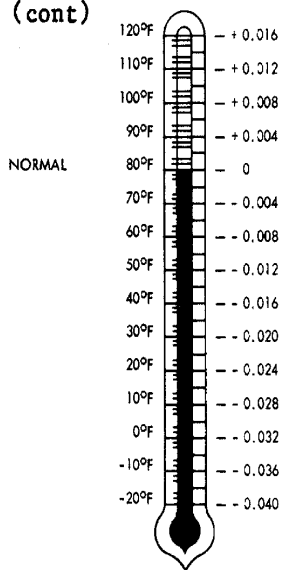

	HYDROMETER READINGS CORRECTED SPECIFIC GRAVITY	
1.280	FULLY CHARGED	
1.250	THREE-FOURTH CHARGED	
1.220	ONE-HALF CHARGED	
1.190	ONE-FOURTH CHARGED	
1.160	LITTLE USEFUL CHARGE	
1.130	DISCHARGED	

Correct hydrometer readings for temperature according to the conversion scale as shown; compare readings with those listed

If the difference between the highest and lowest cell reading is more than 25 points (0.025), charge battery and repeat specific gravity test. If difference between individual cells is still more than 25 points, battery is defective and must be replaced. Install cell covers

TA236293

INSTALLATION

10	Starter	a. Positive cable (4) b. Three new tie straps (18)	a. Route b. Connect Install	Along frame to battery box To starter, para 2-25b At locations noted during removal
11	Transmission, hand side	Negative cable (3) right	a. Route b. Connect	To battery box To transmission, para 2-41j
12	Battery box	Two new tie straps (17)	Install removal	At locations noted during
13	Battery box	a. Two rubber pads (16) b. Four batteries (15) c. Battery warmers	Install Install Install	Use battery carrier, hoist, or battery carrying handles Para 2-73c
14	Battery box	a. Four hold-down brackets (14)	Position	

2-34. BATTERY SYSTEM MAINTENANCE

a. Battery Cables and Batteries (cont).

STEP	LOCATION	ITEM	ACTION	REMARKS
INSTALLATION (cont)				
14 (cont)		b. Two hold-down links (13)	Position	
		c. Four capscrews (12), six washers (11), and six lock-nuts (10)	Install and tighten	Tighten to 70 pounds inch torque. Do not overtighten, or damage to battery cases could result
		d. Four positive lugs (9) and negative lugs (8)	a. Spread b. Install	Spread lugs using terminal spreader Tap on with soft mallet
		e. Eight capscrews (7) and nuts (6)	Tighten	
		f. Six battery cables (5)	Position	On lugs (8 and 9)
		g. Six capscrews (2) and nuts (1)	Install and tighten	
		h. Positive cable (4)	Position	On positive lug (9)
		i. Capscrew (2) and nut (1)	Install and tighten	
		j. Negative cable (3)	Position	On negative lug (8)
		k. Capscrew (2) and nut (1)	Install and tighten	
		l. Tire carrier	Raise and secure	

BATTERY CHARGING

WARNING

Do not smoke or allow open flame near batteries. Batteries release hydrogen, an explosive gas, during charging. Failure to follow this procedure could cause severe injury. If you are injured, obtain medical aid immediately.

15	Battery box	a. Battery charger leads	Connect	Connect positive lead to battery positive post, and charger negative lead to battery negative post
----	-------------	--------------------------	---------	--

2-34. BATTERY SYSTEM MAINTENANCE

a. Battery Cables and Batteries (cont).

STEP	LOCATION	ITEM	ACTION	REMARKS
------	----------	------	--------	---------

BATTERY CHARGING (cont)

15
(cont)

NOTE

Make certain battery cell covers are installed before proceeding.

		b. Battery charger	Turn on	
		c. Battery cell covers	a. Remove	Remove cell covers periodically and check specific gravity (step 9b) and electrolyte level. Add distilled water to maintain level 3/8 inch above plates
16	Batteries (15)	a. Specific gravity	b. Install Check	Check after two hours of battery charging. Use hydrometer. Battery is considered fully charged when the specific gravity does not change. If one or more cells of the battery has a specific gravity less than 1.230 after prolonged charging, the battery is defective and must be replaced
		b. Battery charger	Turn off	Disconnect leads
		c. Battery box lid secure	Close and	Para 2-34b

2-34. BATTERY SYSTEM MAINTENANCE

b. Battery Box.

This task covers:

- a. Removal
- b. Cleaning
- c. Inspection/Repair
- d. Installation

INITIAL SETUP

Tools

No. 1 Common Organizational Maintenance Tool Kit

- Socket wrench set
- Safety glasses
- Welding shop equipment
- Hoist

Equipment Condition

Paragraph Condition Description

- 2-65c Vehicle parked on level surface, engine off, and parking brake applied.
- 2-63c Rear platform removed.
- 2-79a Spare tire mount and spare tire removed.
- 2-12d Cab hydraulic pump removed. External oil filter removed and set aside (lines still connected).

Materials/Parts

- Cleaning solvent Item 1, Appendix C
- Clean cloths Item 2, Appendix C
- Detergent Item 27, Appendix C

Personnel Required

Two Wheel Vehicle Mechanics MOS 63B

KEY

- 1. Capscrews (4)
- 2. Lock washers (4)
- 3. Washers (4)
- 4. Locknuts (3)
- 5. Washers (3)
- 6. Capscrews (3)
- 7. Locknuts (3)
- 8. Washers (3)
- 9. Capscrews (3)
- 10. Battery box
- 11. Grommets (2)
- 12. Nut
- 13. Lock washer
- 14. Clamp

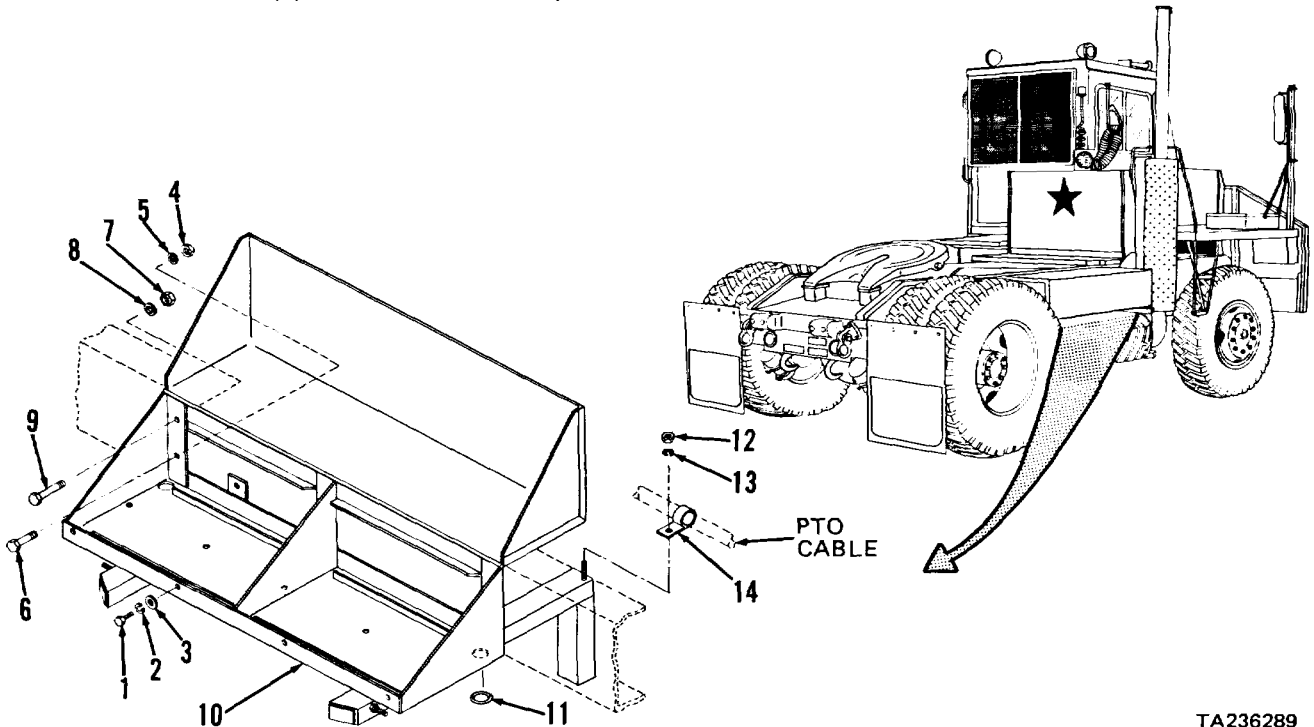

TA236289

2-34. BATTERY SYSTEM MAINTENANCE

b. Battery Box (cont).

STEP	LOCATION	ITEM	ACTION	REMARKS
REMOVAL				
1	Tractor, right side	a. Lock	Remove, if installed	From hasp of battery box (10) lid
		b. Four capscrews (1), lock washers (2), and washers (3)	Remove	

WARNING

Battery box (10) lid is heavy. Secure lid in open position to prevent injury from falling lid. If you are injured, obtain medical aid immediately.

c.	Battery box (10) lid	Raise	Tie or prop up battery box (10) lid in raised position
d.	Battery cables and batteries	Remove	Para 2-34a
e.	Nut (12), lock washer (13), and clamp (14)	Remove	From battery box (10) and PTO cable
f.	Hoist	Attach	To battery box (10)
g.	Three locknuts (4), washers (5), and capscrews (6)	Remove	
h.	Three locknuts (7), washers (8), and capscrews (9)	Remove	
i.	Battery box (10)	Remove	Use hoist
j.	Two grommets (11)	Remove	If necessary for replacement

CLEANING

2		a. Grommets (11)	Clean	Use clean cloth moistened with mild detergent; dry using clean cloths
---	--	------------------	-------	---

2-34. BATTERY SYSTEM MAINTENANCE

b. Battery Box (cont).

STEP	LOCATION	ITEM	ACTION	REMARKS
------	----------	------	--------	---------

CLEANING (cont)

2
(cont)

WARNING

Dry cleaning solvent (P-D-680), used to clean parts is toxic and flammable. Wear protective goggles and gloves and use only in a well ventilated area. Avoid contact with skin, eyes, and clothes and don't breathe vapors. Do not use near open flame or excessive heat and don't smoke when using it. Failure to do so could cause serious injury. If you become dizzy while using cleaning solvent, get fresh air and medical attention immediately. If contact with skin or clothes is made, flush with large amounts of water. If contact with eyes is made, wash eyes with water and seek medical aid immediately. Compressed air must not exceed 30 psi. Wear safety glasses when drying parts with compressed air. Failure to do so could cause serious injury to eyes and possible blindness. If you hurt your eyes or if a foreign object is blown into your eyes, seek medical attention immediately.

b. All other parts	Clean	Use cleaning solvent P-D-680; dry with compressed air
--------------------	-------	---

INSPECTION/REPAIR

3

a. Battery box (10)	Inspect	Repair by welding if cracked, distorted, or hinges damaged. Replace if battery box is beyond economical repair
b. Grommets (10)	Inspect	Replace if cracked, torn, or deteriorated
c. All other parts	Inspect	Replace if cracked, broken, distorted, or threads damaged

INSTALLATION

4

Tractor, right side

a. Two grommets (11)	Install	If necessary
b. Battery box (10)	Position	Use hoist; align mounting holes

2-34. BATTERY SYSTEM MAINTENANCE

b. Battery Box (cont).

STEP	LOCATION	ITEM	ACTION	REMARKS
INSTALLATION (cont)				
4 (cont)		c. Three capscrews (9), washers (8), and locknuts (7)	Install and tighten	
		d. Three capscrews (6), washers (5), and locknuts (4)	Install and tighten	
		e. Hoist	Remove	From battery box (10)

WARNING

Battery box (10) lid is heavy. Secure lid in open position to prevent injury from falling lid. If you are injured, obtain medical aid immediately.

f.	Batteries and cables	Install	Para 2-34a
g.	Battery warmers	Install	Para 2-73c
h.	Battery box (10) lid	Close	
i.	Four washers (3), lock washers (2), and capscrews (1)	Install and tighten	Secures lid
j.	Lock	Install	On hasp of lid
k.	Clamp (14) (10)	Position	On PTO cable and battery box
l.	Nut (12) and lock washer (13)	Install and tighten	Secures clamp (14)
m.	External oil filter	Mount	Para 2-12d
n.	Cab hydraulic pump	Install	Para 2-79a
o.	Rear platform	Install	Para 2-65c
p.	Spare tire mount and spare tire	Install	Para 2-63c

2-35. WIRING HARNESS MAINTENANCE

- a. Cab Harnesses.
- (1) Upper Cab Harness.

This task covers:

- a. Cleaning
- b. Inspection/Repair
- c. Testing

INITIAL SETUP

Tools

No. 1 Common Organizational Maintenance
Tool Kit

- Multimeter
- Tool kit, electrical connector
- Crimping tool
- Wire stripper

Materials/Parts

- Cleaning solvent Item 1, Appendix C2-34a
- Clean cloths Item 2, Appendix C
- Tags Item 14, Appendix C2-26g(1)
- Electrical tape Item 37, Appendix C

Personnel Required

Wheel Vehicle Mechanic MOS 63B

Equipment Condition

Paragraph Condition Description

Vehicle parked on level surface, engine off, and parking brake applied.
Battery ground cable disconnected.
Instrument panel raised.

KEY

- 1. Connector
- 2. Upper cab harness

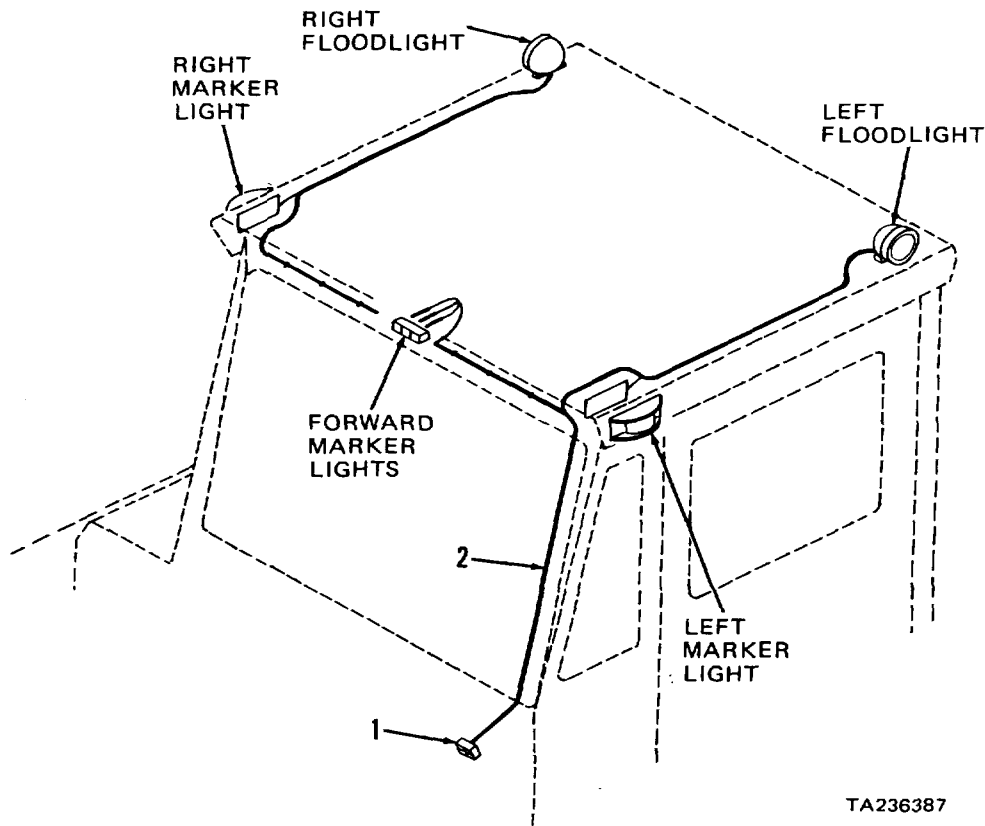

2-388

TA236387

2-35. WIRING HARNESS MAINTENANCE

a. Cab Harnesses (cont).

(1) Upper Cab Harness (cont).

STEP	LOCATION	ITEM	ACTION	REMARKS
CLEANING				
1		a. Upper cab harness (2)	Clean	Wipe with a clean, dry cloth where wiring is accessible

WARNING

Dry cleaning solvent (P-D-680), used to clean parts is toxic and flammable. Wear protective goggles and gloves and use only in a well ventilated area. Avoid contact with skin, eyes, and clothes and don't breathe vapors. Do not use near open flame or excessive heat and don't smoke when using it. Failure to do so could cause serious injury. If you become dizzy while using cleaning solvent, get fresh air and medical attention immediately. If contact with skin or clothes is made, flush with large amounts of water. If contact with eyes is made, wash eyes with water and seek medical aid immediately.

b. Connector (1)	Clean	Use clean cloth moistened with cleaning solvent P-D-680; dry with clean cloths
------------------	-------	--

INSPECTION/REPAIR

2	a. Connector (1)	a. Tag b. Disconnect c. Inspect	Replace upper cab harness (2) if connector bent or damaged (notify direct support maintenance)
---	------------------	---------------------------------------	--

NOTE

Gage of replacement wire must be greater than or equal to gage of defective wire.

2-35. WIRING HARNESS MAINTENANCE

a. Cab Harnesses (cont).

(1) Upper Cab Harness (cont).

STEP	LOCATION	ITEM	ACTION	REMARKS
INSPECTION/REPAIR (cont)				
2 (cont)		b. Upper cab	Inspect harness (2)	Repair if insulation frayed or conductor broken. Wrap electrical tape over frayed insulation. If broken conductor is accessible, cut a length of same gage wire and splice using insulated splice connector; if wire is not accessible, replace harness (notify direct support maintenance)
TESTING				
3	Cab	Upper cab harness (2)	Test continuity	Use multimeter set to X1 ohms range (refer to electrical system wiring schematic); refer to step (2) above for repair of broken conductor
4	Cab, inside	Connector (1)	Connect	As tagged
5	Cab, inside	Front instrument panel	Lower and secure	Para 2-26g(1)
6	Battery box	Battery ground cable	Connect	Para 2-34a
7	Cab	a. Key switch b. Lights, controls, and indicators	Turn on Check operation	If lights, controls, or indicators do not operate, refer to para 2-17 thru 2-23 for troubleshooting procedures
		c. Key switch	Turn off	

2-35. WIRING HARNESS MAINTENANCE

a. Cab Harnesses (cont).

(2) Lower Cab Harness.

This task covers:

- a. Cleaning
- b. Inspection/Repair
- c. Testing

INITIAL SETUP

Tools

No. 1 Common Organizational Maintenance

Tool Kit

- Multimeter
- Tool kit, electrical connector
- Crimping tool
- Wire stripper

Materials/Parts

- Cleaning solvent Item 1, Appendix C
- Clean cloths Item 2, Appendix C
- Tags Item 14, Appendix C
- Electrical tape Item 37, Appendix C

Personnel Required

Wheel Vehicle Mechanic MOS 63B

Equipment Condition

- | Paragraph | Condition Description |
|-----------|---|
| 2-34a | Vehicle parked on level surface, engine off, and parking brake applied. |
| 2-26g(1) | Battery ground cable disconnected.
Instrument panel raised. |

KEY

- 1. Connector
- 2. Connector
- 3. Connector
- 4. Lower cab harness

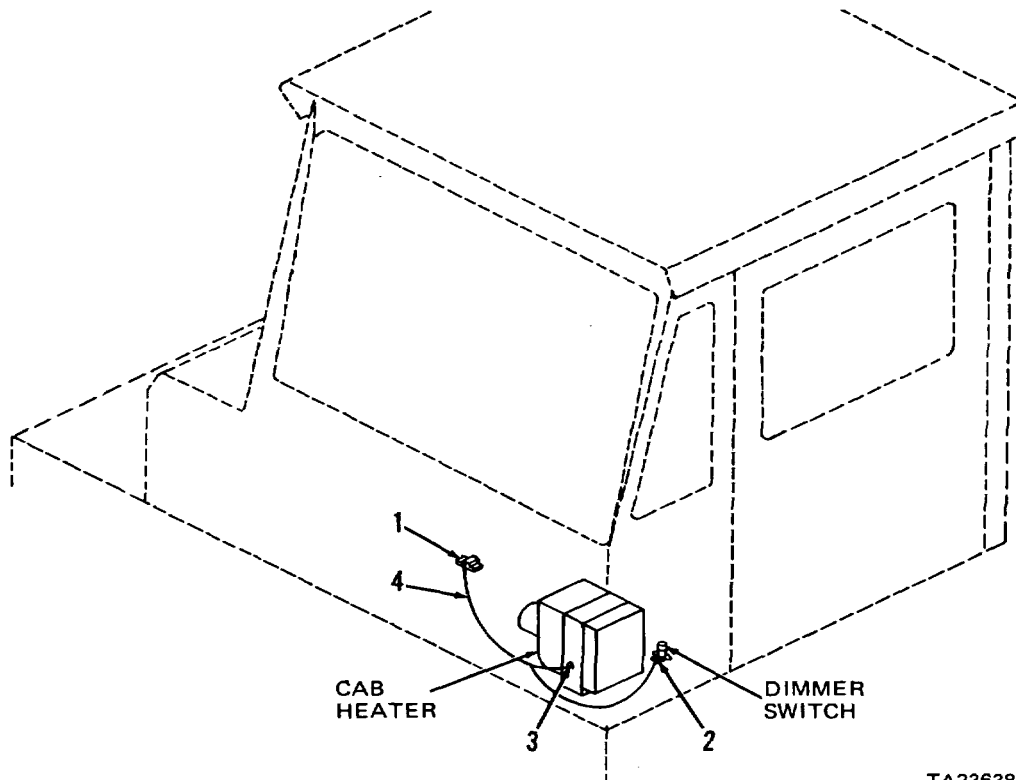

2-391

TA236388

2-35. WIRING HARNESS MAINTENANCE

a. Cab Harnesses (cont).

(2) Lower Cab Harness (cont).

STEP	LOCATION	ITEM	ACTION	REMARKS
------	----------	------	--------	---------

CLEANING

1		a. Lower cab harness (4)	Clean	Wipe with a clean, dry cloth where wiring is accessible
---	--	--------------------------	-------	---

WARNING

Dry cleaning solvent (P-D-680), used to clean parts is toxic and flammable. Wear protective goggles and gloves and use only in a well ventilated area. Avoid contact with skin, eyes, and clothes and don't breathe vapors. Do not use near open flame or excessive heat and don't smoke when using it. Failure to do so could cause serious injury. If you become dizzy while using cleaning solvent, get fresh air and medical attention immediately. If contact with skin or clothes is made, flush with large amounts of water. If contact with eyes is made, wash eyes with water and seek medical aid immediately.

		b. Connectors (1, 2, and 3)	Clean	Use clean cloth moistened with cleaning solvent P-D-680; dry with clean cloths
--	--	-----------------------------	-------	--

INSPECTION/REPAIR

2	Cab, inside	a. Connectors (1, 2, and 3)	Tag	
		b. Connector (1)	Disconnect	Para 2-35c(1)
		c. Connector (2)	Disconnect	Para 2-26a(5)
		d. Connector (3)	Disconnect	Para 2-73a
		e. Connectors (1, 2, and 3)	Inspect	Replace lower cab harness (4) if connector bent or damaged (notify direct support maintenance)

NOTE

Gage of replacement wire must be greater than or equal to gage of defective wire.

2-35. WIRING HARNESS MAINTENANCE (CONT)

- a. Cab Harnesses (cont).
- (2) Lower Cab Harness (cont).

STEP	LOCATION	ITEM	ACTION	REMARKS
INSPECTION/REPAIR (cont)				
2 (cont)		f. Lower cab harness (4)	Inspect	Repair if insulation frayed or conductor broken. Wrap electrical tape over frayed insulation. If broken conductor is accessible, cut a length of same gage wire and splice using insulated splice connector; if wire is not accessible, replace harness (notify direct support maintenance)
TESTING				
3	Cab	Lower cab harness (4)	Test continuity	Use multimeter set to X1 ohms range (refer to electrical system wiring schematic); refer to step (2) above for repair of broken conductor
4	Cab, inside	a. Connector (3) b. Connector (2) c. Connector (1) d. Instrument panel	Connect Connect Connect Lower and secure	As tagged, para 2-73a As tagged, para 2-26a(5) As tagged, para 2-35c(1) Para 2-26g(1)
5	Battery box	Battery ground cable	Connect	Para 2-34a
6	Cab	a. Key switch b. Lights, controls, and indicators c. Key switch	Turn on Check operation Turn off	If lights, controls, or indicators do not operate, refer to para 2-17 thru 2-23 for troubleshooting procedures

2-35. WIRING HARNESS MAINTENANCE (CONT)

b. Chassis Harnesses.

(1) Front Chassis Harness.

This task covers: a. Cleaning c. Testing
b. Inspection/Repair

INITIAL SETUP:

Tools

No. 1 Common Organizational Maintenance Tool Kit

- Multimeter
- Tool kit, electrical connector
- Crimping tool
- Wire stripper

Personnel Required

Wheel Vehicle Mechanic MOS 63B

Equipment Condition

Paragraph Condition Description

Materials/Parts

- Cleaning solvent Item 1, Appendix C
- Clean cloths Item 2, Appendix C
- Tags Item 14, Appendix C
- Electrical tape Item 37, Appendix C

2-34a

Vehicle parked on level surface, engine off, and parking brake applied. Cab tilted 45 degrees. Battery ground cable disconnected.

KEY

- 1. Connector
- 2. Connector
- 3. Front chassis harness

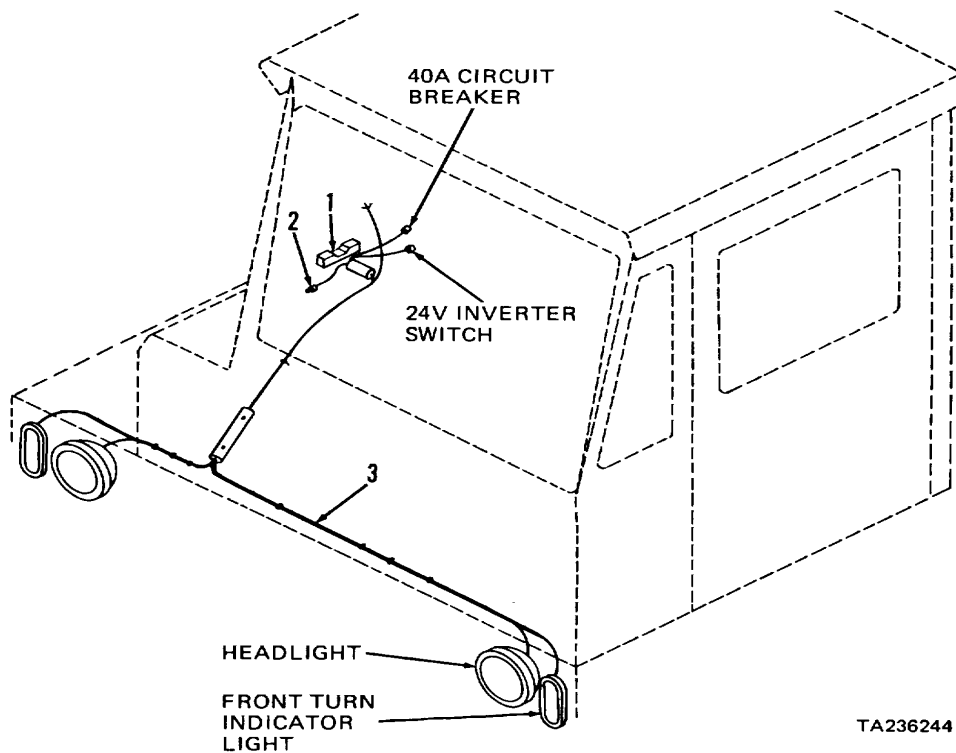

2-394

TA236244

2-35. WIRING HARNESS MAINTENANCE (CONT)

- b. Chassis Harnesses (cont).
 - (1) Front Chassis Harness (cont).

STEP	LOCATION	ITEM	ACTION	REMARKS
CLEANING				
1		a. Front chassis harness (3)	Clean	Wipe with a clean, dry cloth where wiring is accessible

WARNING

Dry cleaning solvent (P-D-680), used to clean parts is toxic and flammable. Wear protective goggles and gloves and use only in a well ventilated area. Avoid contact with skin, eyes, and clothes and don't breathe vapors. Do not use near open flame or excessive heat and don't smoke when using it. Failure to do so could cause serious injury. If you become dizzy while using cleaning solvent, get fresh air and medical attention immediately. If contact with skin or clothes is made, flush with large amounts of water. If contact with eyes is made, wash eyes with water and seek medical aid immediately.

b. Connectors (1 and 2)	Clean	Use clean cloth moistened with cleaning solvent P-D-680; dry with clean cloths
-------------------------	-------	--

INSPECTION/REPAIR

2	a. Connectors (1 and 2)	Tag	
	b. Connector (1)	Disconnect	Para 2-35d
	c. Connector (2)	Disconnect	From right hand instrument panel harness
	d. Connectors (1 and 2)	Inspect	Replace front chassis harness (3) if connector bent or damaged (notify direct support maintenance)

NOTE

Gage of replacement wire must be greater than or equal to gage of defective wire.

2-35. WIRING HARNESS MAINTENANCE (CONT)

b. Chassis Harnesses (cont).

(1) Front Chassis Harness (cont).

STEP	LOCATION	ITEM	ACTION	REMARKS
INSPECTION/REPAIR (cont)				
2 (cont)		e. Front chassis harness (3)	Inspect	Repair if insulation frayed or conductor broken. Wrap electrical tape over frayed insulation. If broken conductor is accessible, cut a length of same gage wire and splice using insulated splice connector; if wire is not accessible, replace harness (notify direct support maintenance)
TESTING				
3	Cab	Front chassis harness (3)	Test continuity	Use multimeter set to XI ohms range (refer to electrical system wiring schematic); refer to step (2) above for repair of broken conductor
4	Cab, inside	a. Connector (2) b. Connector (1)	Connect Connect	As tagged As tagged, para 2-35d
5 position	Cab tilt pump	Cab		Lower To normal operating
6	Battery box	Battery ground cable	Connect	Para 2-34a
7	Cab	a. Key switch b. Lights, controls, and indicators	Turn on Check operation	If lights, controls, or indicators do not operate, refer to para 2-17 thru 2-23 for troubleshooting procedures
		c. Key switch	Turn off	

2-35. WIRING HARNESS MAINTENANCE (CONT)

b. Chassis Harnesses (cont).

(2) Rear Chassis Harness.

This task covers: a. Cleaning c. Testing
 b. Inspection/Repair

INITIAL SETUP:

Tools

No. 1 Common Organizational Maintenance Tool Kit

- Multimeter
- Tool kit, electrical connector
- Crimping tool
- Wire stripper

Personnel Required

Wheel Vehicle Mechanic MOS 63B

Equipment Condition

Paragraph Condition Description

Materials/Parts

- Cleaning solvent Item 1, Appendix C
- Clean cloths Item 2, Appendix C
- Tags Item 14, Appendix C
- Electrical tape Item 37, Appendix C

2-34a

Vehicle parked on level surface, engine off, and parking brake applied. Cab tilted 45 degrees. Battery ground cable disconnected.

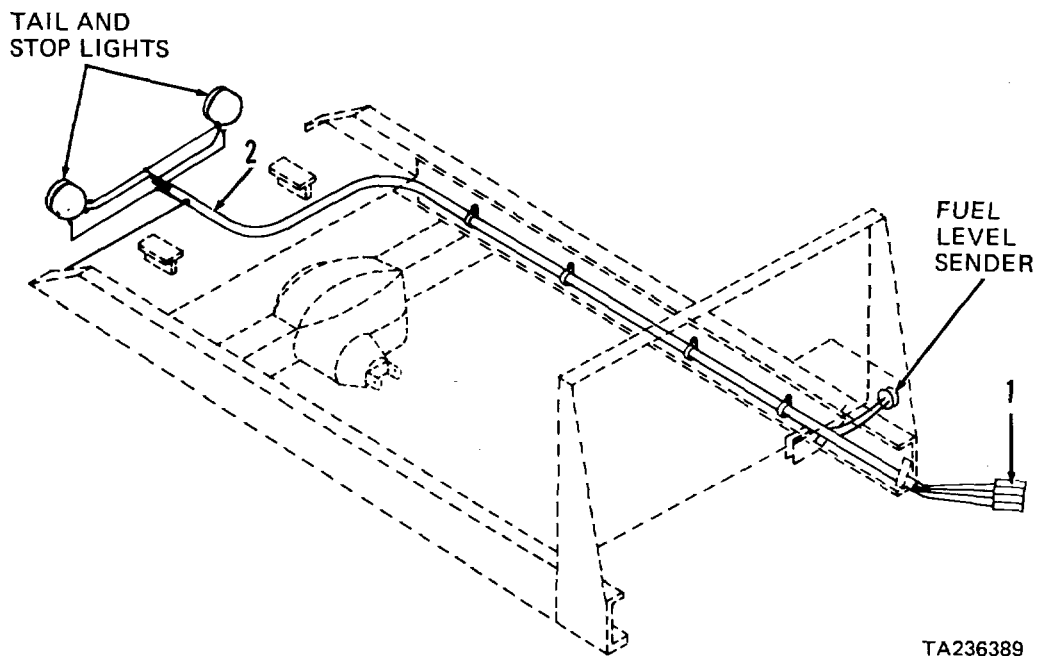

KEY

- 1. Connector
- 2. Rear chassis harness

2-35. WIRING HARNESS MAINTENANCE (CONT)

- b. Chassis Harnesses (cont).
- (2) Rear Chassis Harness (cont).

STEP	LOCATION	ITEM	ACTION	REMARKS
CLEANING				
1		a. Rear chassis harness (2)	Clean	Wipe with a clean, dry cloth where wiring is accessible
<u>WARNING</u>				
Dry cleaning solvent (P-D-680), used to clean parts is toxic and flammable. Wear protective goggles and gloves and use only in a well ventilated area. Avoid contact with skin, eyes, and clothes and don't breathe vapors. Do not use near open flame or excessive heat and don't smoke when using it. Failure to do so could cause serious injury. If you become dizzy while using cleaning solvent, get fresh air and medical attention immediately. If contact with skin or clothes is made, flush with large amounts of water. If contact with eyes is made, wash eyes with water and seek medical aid immediately.				
		b. Connector (1)	Clean	Use clean cloth moistened with cleaning solvent P-D-680; dry with clean cloths

INSPECTION/REPAIR

2		a. Connector (1)	a. Tag b. Disconnect c. Inspect	Replace rear chassis harness (2) if connector bent or damaged (notify direct support maintenance)
---	--	------------------	---------------------------------------	---

NOTE

Gage of replacement wire must be greater than or equal to gage of defective wire.

2-35. WIRING HARNESS MAINTENANCE (CONT)

- b. Chassis Harnesses (cont).
- (2) Rear Chassis Harness (cont).

STEP	LOCATION	ITEM	ACTION	REMARKS
INSPECTION/REPAIR (cont)				
2 (cont)		b. Rear chassis harness (2)	Inspect	Repair if insulation frayed or conductor broken. Wrap electrical tape over frayed insulation. If broken conductor is accessible, cut a length of same gage wire and splice using insulated splice connector; if wire is not accessible, replace harness (notify direct support maintenance)
TESTING				
3	Cab	Rear chassis harness (2)	Test continuity	Use multimeter set to XI ohms range (refer to electrical system wiring schematic); refer to step (2) above for repair of broken conductor
4	Cab, inside	Connector (1)	Connect	As tagged
5	Battery box	Battery ground cable	Connect	Para 2-34a
6 position	Cab tilt pump	Cab		Lower To normal operating
7	Cab	a. Key switch b. Lights, controls, and indicators	Turn on Check operation	If lights, controls, or indicators do not operate, refer to para 2-17 thru 2-23 for troubleshooting procedures
		c. Key switch	Turn off	

2-35. WIRING HARNESS MAINTENANCE (CONT)

c. Instrument Panel Harnesses.

(1) Front Panel Harness.

This task covers: a. Cleaning c. Testing
 b. Inspection/Repair

INITIAL SETUP:

Tools

No. 1 Common Organizational Maintenance Tool Kit

- Multimeter
- Tool kit, electrical connector
- Crimping tool
- Wire stripper

Materials/Parts

- Cleaning solvent Item 1, Appendix C
- Clean cloths Item 2, Appendix C
- Tags Item 14, Appendix C
- Electrical tape Item 37, Appendix C

Equipment Condition

Paragraph	Condition Description
	Vehicle parked on level surface, engine off, and parking brake applied.
2-34a	Battery ground cable disconnected.
2-26g(1)	Instrument panel raised.
2-35d	Chassis harness plug disconnected from cab firewall.

Personnel Required

Wheel Vehicle Mechanic MOS 63B

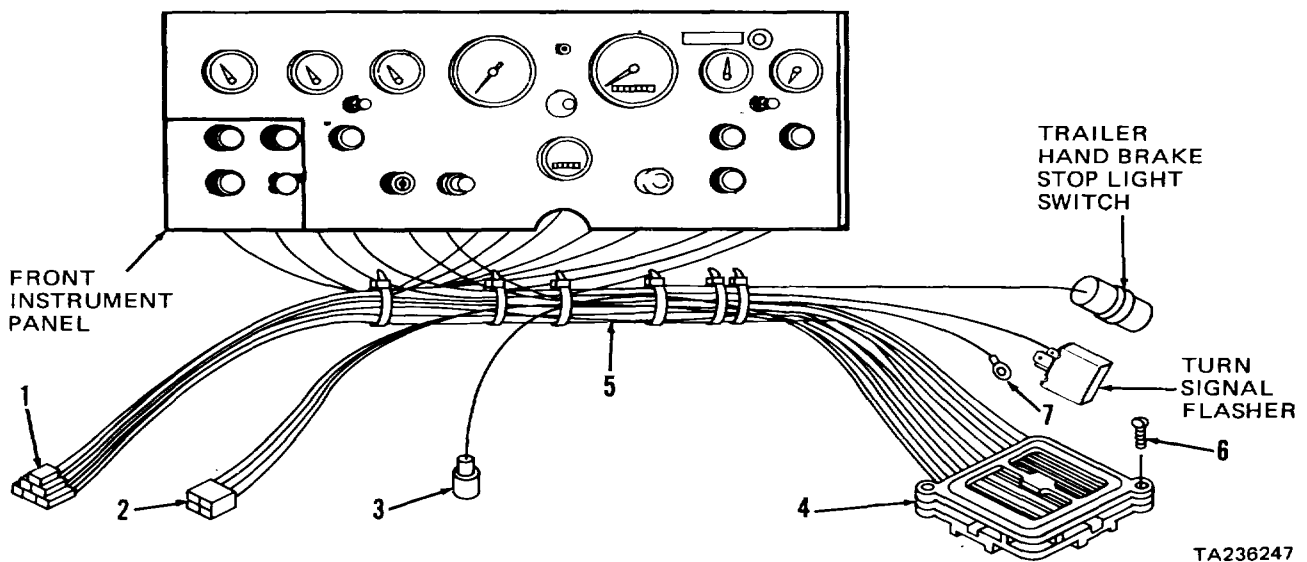

TA236247

KEY

- 1. Connector
- 2. Connector
- 3. Steering column connector
- 4. Fuse block and bulkhead connector
- 5. Front panel harness
- 6. Capscrews (2)
- 7. Electrical (ground) lead

2-35. WIRING HARNESS MAINTENANCE (CONT)

- c. Instrument Panel Harnesses (cont).
 - (1) Front Panel Harness (cont).

STEP	LOCATION	ITEM	ACTION	REMARKS
CLEANING				
1		a. Front panel harness (5)	Clean	Wipe with a clean, dry cloth where wiring is accessible
<u>WARNING</u>				
Dry cleaning solvent (P-D-680), used to clean parts is toxic and flammable. Wear protective goggles and gloves and use only in a well ventilated area. Avoid contact with skin, eyes, and clothes and don't breathe vapors. Do not use near open flame or excessive heat and don't smoke when using it. Failure to do so could cause serious injury. If you become dizzy while using cleaning solvent, get fresh air and medical attention immediately. If contact with skin or clothes is made, flush with large amounts of water. If contact with eyes is made, wash eyes with water and seek medical aid immediately.				
		b. Connectors (1 thru 4)	Clean	Use cloth moistened with cleaning solvent P-D-680; dry with clean cloths
INSPECTION/REPAIR				
2		a. Connectors (1, 2, and 3)	Tag and disconnect	
		b. Two capscrews (6) and electrical lead (7)	Remove	Note location of electrical lead (7)
		c. Fuse block and bulkhead connector (4)	Remove	From cab firewall
		d. Trailer hand brake stop light switch	Disconnect wires	Para 2-32f(2)
		e. Connectors (1 thru 4)	Inspect	Replace front panel harness (5) if connector bent or damaged (notify direct support maintenance)

NOTE

Gage of replacement wire must be greater than or equal to gage of defective wire.

2-35. WIRING HARNESS MAINTENANCE (CONT)

c. Instrument Panel Harnesses (cont).

(1) Front Panel Harness (cont).

STEP	LOCATION	ITEM	ACTION	REMARKS
INSPECTION/REPAIR (cont)				
2 (cont)		f. Front panel harness (5)		Inspect: repair if insulation frayed or conductor broken. Wrap electrical tape over frayed insulation. If broken conductor is accessible, cut a length of same gage wire and splice using insulated splice connector; if wire is not accessible, replace harness (notify direct support maintenance)
TESTING				
3	Cab	Front panel harness (5)		Test continuity: use multimeter set to X1 ohms range (refer to electrical system wiring schematic); refer to step 2e above for repair of broken conductor
4	Cab, inside	a. Connectors (1 thru 3)	Connect	As tagged
		b. Fuse block and bulkhead connector (4)	Position	In cab firewall
		c. Electrical lead (7)	Position	At location noted during removal
		d. Two capscrews (6)	Install and tighten	
		e. Trailer hand brake stop light switch	Connect wires	Para 2-32f(2)
		f. Instrument panel	Lower and secure	Para 2-26g(1)
5	Cab firewall, under hood	Chassis harness plug	Connect	Para 2-35d
6	Battery box	Battery ground cable	Connect	Para 2-34a
7	Cab	a. Key switch	Turn on	
		b. Lights, controls, and indicators	Check operation: if lights, controls, or indicators do not operate, refer to para 2-17 thru 2-23 for troubleshooting procedures	
		c. Key switch	Turn off	

2-35. WIRING HARNESS MAINTENANCE (CONT)

c. Instrument Panel Harnesses (cont).

(2) Right Corner Panel Harness.

This task covers: a. Cleaning c. Testing
 b. Inspection/Repair

INITIAL SETUP:

Tools

No. 1 Common Organizational Maintenance Tool Kit

- Multimeter
- Tool kit, electrical connector
- Crimping tool
- Wire stripper

Personnel Required

Wheel Vehicle Mechanic MOS 63B

Equipment Condition

Paragraph Condition Description

Materials/Parts

- Cleaning solvent Item 1, Appendix C
- Clean cloths Item 2, Appendix C
- Tags Item 14, Appendix C
- Electrical tape Item 37, Appendix C

2-34a

Vehicle parked on level surface, engine off, and parking brake applied. Cab tilted 45 degrees. Battery ground cable disconnected.

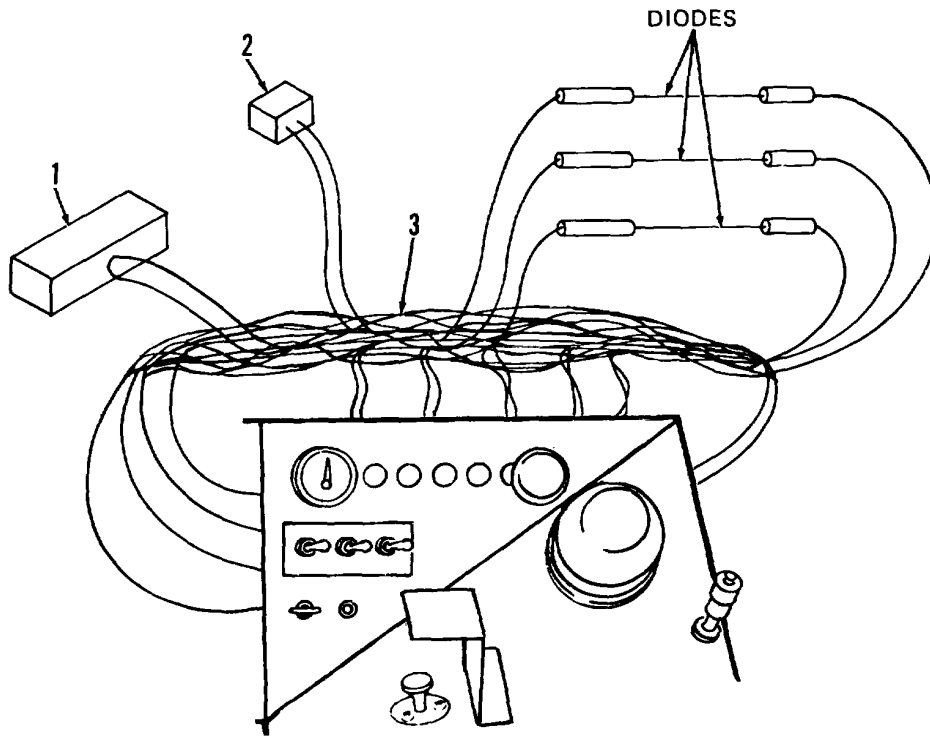

TA236175

KEY

- 1. Connector
- 2. Connector
- 3. Right corner panel harness

2-35. WIRING HARNESS MAINTENANCE (CONT)

- c. Instrument Panel Harnesses (cont).
- (2) Right Corner Panel Harness (cont).

STEP	LOCATION	ITEM	ACTION	REMARKS
------	----------	------	--------	---------

CLEANING

1		a. Right corner panel harness (3)	Clean	Wipe with a clean, dry cloth where wiring is accessible
---	--	-----------------------------------	-------	---

WARNING

Dry cleaning solvent (P-D-680), used to clean parts is toxic and flammable. Wear protective goggles and gloves and use only in a well ventilated area. Avoid contact with skin, eyes, and clothes and don't breathe vapors. Do not use near open flame or excessive heat and don't smoke when using it. Failure to do so could cause serious injury. If you become dizzy while using cleaning solvent, get fresh air and medical attention immediately. If contact with skin or clothes is made, flush with large amounts of water. If contact with eyes is made, wash eyes with water and seek medical aid immediately.

		b. Connectors (1 and 2)	Clean	Use clean cloth moistened with cleaning solvent P-D-680; dry with clean cloths
--	--	-------------------------	-------	--

INSPECTION/REPAIR

2		a. Connectors (1 and 2)	a. Tag b. Disconnect c. Inspect	Replace right corner panel harness (3) if connector bent or damaged (notify direct support maintenance)
---	--	-------------------------	---------------------------------------	---

NOTE

Gage of replacement wire must be greater than or equal to gage of defective wire.

2-35. WIRING HARNESS MAINTENANCE (CONT)

- c. Instrument Panel Harnesses (cont).
- (2) Right Corner Panel Harness (cont).

STEP	LOCATION	ITEM	ACTION	REMARKS
INSPECTION/REPAIR (cont)				
2 (cont)		b. Right corner panel harness (3)	Inspect	Repair if insulation frayed or conductor broken. Wrap electrical tape over frayed insulation. If broken conductor is accessible, cut a length of same gage wire and splice using insulated splice connector; if wire is not accessible, replace harness (notify direct support maintenance)
TESTING				
3	Cab	Right corner panel harness (3)	Test continuity	Use multimeter set to X1 ohms range (refer to electrical system wiring schematic); refer to step (2) above for repair of broken conductor
4	Cab, inside	Connectors (1 and 2)	Connect	As tagged
5 position	Cab tilt pump	Cab		Lower To normal operating
6	Battery box	Battery ground cable	Connect	Para 2-34a
7	Cab	a. Key switch b. Lights, controls, and indicators	Turn on Check operation	If lights, controls, or indicators do not operate, refer to para 2-17 thru 2-23 for troubleshooting procedures
		c. Key switch	Turn off	

2-35. WIRING HARNESS MAINTENANCE (CONT)

c. Instrument Panel Harnesses (cont).

(3) Right Panel Harness.

This task covers: a. Cleaning c. Testing
b. Inspection/Repair

INITIAL SETUP:

Tools

- No. 1 Common Organizational Maintenance Tool Kit
- Multimeter
- Tool kit, electrical connector
- Crimping tool
- Wire stripper

Personnel Required

Wheel Vehicle Mechanic MOS 63B

Equipment Condition

Paragraph	Condition Description
2-34a	Vehicle parked on level surface, engine off, and parking brake applied. Battery ground cable disconnected. Cab tilted 45 degrees.

Materials/Parts

- Cleaning solvent Item 1, Appendix C
- Clean cloths Item 2, Appendix C
- Tags Item 14, Appendix C
- Electrical tape Item 37, Appendix C

KEY

- 1. Connector
- 2. Connector
- 3. Connector
- 4. Connector
- 5. Right panel harness

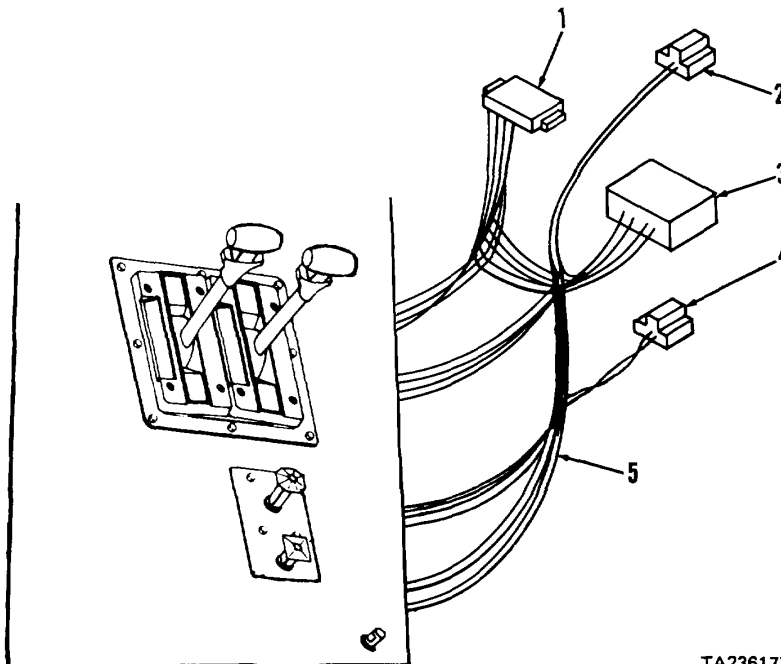

TA236177

2-35. WIRING HARNESS MAINTENANCE (CONT)

- c. Instrument Panel Harnesses (cont).
- (3) Right Panel Harness (cont).

STEP	LOCATION	ITEM	ACTION	REMARKS
CLEANING				
1		a. Right panel harness (5)	Clean	Wipe with a clean, dry cloth where wiring is accessible

WARNING

Dry cleaning solvent (P-D-680), used to clean parts is toxic and flammable. Wear protective goggles and gloves and use only in a well ventilated area. Avoid contact with skin, eyes, and clothes and don't breathe vapors. Do not use near open-flame or excessive heat and don't smoke when using it. Failure to do so could cause serious injury. If you become dizzy while using cleaning solvent, get fresh air and medical attention immediately. If contact with skin or clothes is made, flush with large amounts of water. If contact with eyes is made, wash eyes with water and seek medical aid immediately.

		b. Connectors (1 thru 4)	Clean	Use clean cloth moistened with cleaning solvent P-D-680; dry with clean cloths
--	--	--------------------------	-------	--

INSPECTION/REPAIR

2	Right corner panel, underside	a. Connector (1) b. Connectors (2 thru 4) c. Connectors (1 thru 4)	Disconnect a. Tag b. Disconnect Inspect	Para 2-35d Replace right panel harness (5) if connector bent or damaged (notify direct support maintenance)
---	-------------------------------	--	--	--

NOTE

Gage of replacement wire must be greater than or equal to gage of defective wire.

2-35. WIRING HARNESS MAINTENANCE (CONT)

c. Instrument Panel Harnesses (cont).

(3) Right Panel Harness (cont).

STEP	LOCATION	ITEM	ACTION	REMARKS
INSPECTION/REPAIR (cont)				
2 (cont)		d. Right panel harness (5)	Inspect	Repair if insulation frayed or conductor broken. Wrap electrical tape over frayed insulation. If broken conductor is accessible, cut a length of same gage wire and splice using insulated splice connector; if wire is not accessible, replace harness (notify direct support maintenance)
TESTING				
3	Right corner panel, underside	a. Right panel harness (5)	Test continuity	Use multimeter set to X1 ohms range (refer to electrical system wiring schematic); refer to step (2) above for repair of broken conductor
		b. Connectors (2 thru 4)	Connect	As tagged
		c. Connector (1)	Connect	Para 2-35d
4 position	Cab tilt pump	Cab		Lower To normal operating
5	Battery box	Battery ground cable	Connect	Para 2-34a
6	Cab	a. Key switch	Turn on	If lights, controls, or indicators do not operate, refer to para 2-17 thru 2-23 for troubleshooting procedures
		b. Lights, controls, and indicators	Check operation	
		c. Key switch	Turn off	

2-35. WIRING HARNESS MAINTENANCE (CONT)

d. Engine Harness.

This task covers: a. Cleaning c. Testing
 b. Inspection/Repair

INITIAL SETUP:

Tools

No. 1 Common Organizational Maintenance Tool Kit

- Combination wrench set
- Multimeter
- Tool kit, electrical connector
- Crimping tool
- Wire stripper

Materials/Parts

- Cleaning solvent Item 1, Appendix C
- Clean cloths Item 2, Appendix C
- Tags Item 14, Appendix C
- Electrical tape Item 37, Appendix C

Personnel Required

Wheel Vehicle Mechanic MOS 63B

Equipment Condition

Paragraph	Condition Description
2-34a	Vehicle parked on level surface, engine off, and parking brake applied. Battery ground cable disconnected.
2-65d	Heat shield removed. Cab tilted 45 degrees.

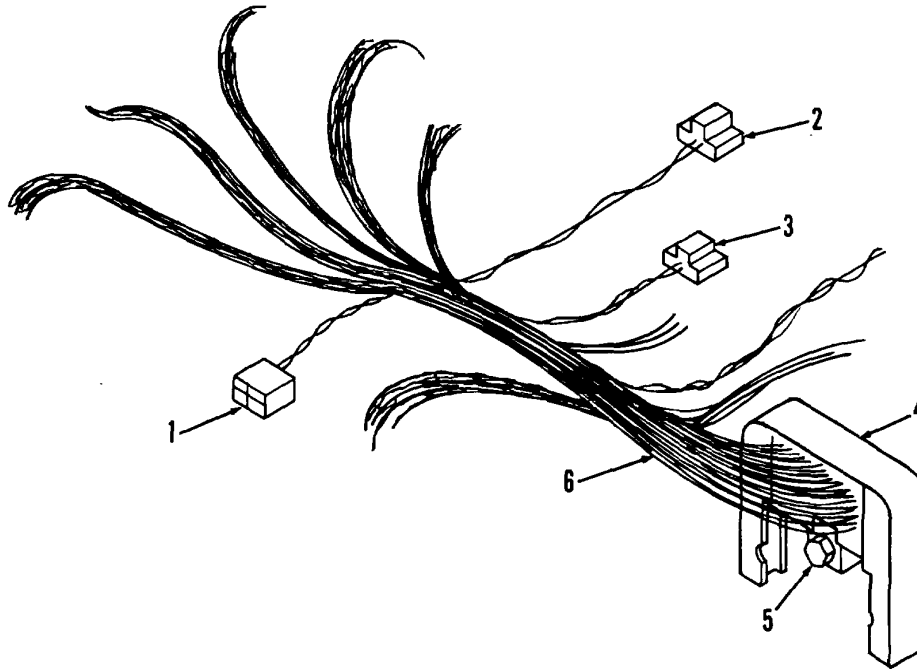

TA236179

KEY

- 1. Connector
- 2. Connector
- 3. Connector
- 4. Chassis harness connector
- 5. Capscrew
- 6. Engine harness

2-35. WIRING HARNESS MAINTENANCE (CONT)

d. Engine Harness (cont).

STEP	LOCATION	ITEM	ACTION	REMARKS
CLEANING				
1		a. Engine harness (6)	Clean	Wipe with a clean, dry cloth where wiring is accessible

WARNING

Dry cleaning solvent (P-D-680), used to clean parts is toxic and flammable. Wear protective goggles and gloves and use only in a well ventilated area. Avoid contact with skin, eyes, and clothes and don't breathe vapors. Do not use near open flame or excessive heat and don't smoke when using it. Failure to do so could cause serious injury. If you become dizzy while using cleaning solvent, get fresh air and medical attention immediately. If contact with skin or clothes is made, flush with large amounts of water. If contact with eyes is made, wash eyes with water and seek medical aid immediately.

b. Connectors (1 thru 4)	Clean	Use cloth moistened with cleaning solvent P-D-680; dry with clean cloths
--------------------------	-------	--

INSPECTION/REPAIR

2	Engine and frame rails	a. Capscrew (5)	Loosen	
		b. Connectors (1 thru 4)	a. Tag b. Disconnect	
		c. Front chassis and right instrument panel plugs	Disconnect	Slip out of tracks in chassis harness connector (4)
		d. Connectors (1 thru 4)	Inspect	Replace engine harness (6) if connector bent or damaged (notify direct support maintenance)

NOTE

Gage of replacement wire must be greater than or equal to gage of defective wire.

2-35. WIRING HARNESS MAINTENANCE (CONT)

d. Engine Harness (cont).

STEP	LOCATION	ITEM	ACTION	REMARKS
INSPECTION/REPAIR (cont)				
2 (cont)		e. Engine harness (6)	Inspect: repair if insulation frayed or conductor broken. Wrap electrical tape over frayed insulation. If broken conductor is accessible, cut a length of same gage wire and splice using insulated splice connector; if wire is not accessible, replace harness (notify direct support maintenance)	
TESTING				
3	Engine and frame rails	a. Engine harness (6)	Test continuity: use multimeter set to X1 ohms range (refer to electrical system wiring schematic); refer to step 2e above for repair of broken conductor	
		b. Front chassis and right instrument panel plugs	Connect	Slide into tracks in chassis harness connector (4)
		c. Connectors (1 thru 4)	Connect	As tagged; tighten capscrew (5)
4	Battery box	Battery ground cable	Connect	Para 2-34a
5	Left hand frame rail	Heat shield	Install	Para 2-65d
6 position	Cab tilt pump	Cab		Lower To normal operating
7	Cab	a. Key switch	Turn on	
		b. Lights, controls, and indicators	Check operation: if lights, controls, or indicators do not operate, refer to para 2-17 thru 2-23 for troubleshooting procedures	
		c. Key switch	Turn off	

2-35. WIRING HARNESS MAINTENANCE (CONT)

e. Ground Straps.

This task covers: a. Removal c. Inspection
 b. Cleaning d. Installation

INITIAL SETUP:

Tools

No. 1 Common Organizational Maintenance Tool Kit

- Socket wrench set
- Safety glasses

Materials/Parts

Cleaning solvent Item 1, Appendix C
 Clean cloths Item 2, Appendix C

Equipment Condition

Paragraph	Condition Description
2-34a	Vehicle parked on level surface, engine off, and parking brake applied. Battery ground cable disconnected. Cab tilted 45 degrees.

Personnel Required

Wheel Vehicle Mechanic MOS 63B

KEY

1. Nut
2. Washer
3. Nut
4. Washer
5. Ground strap
6. Nut
7. Lock washer
8. Capscrew
9. Washer
10. Locknut
11. Ground strap

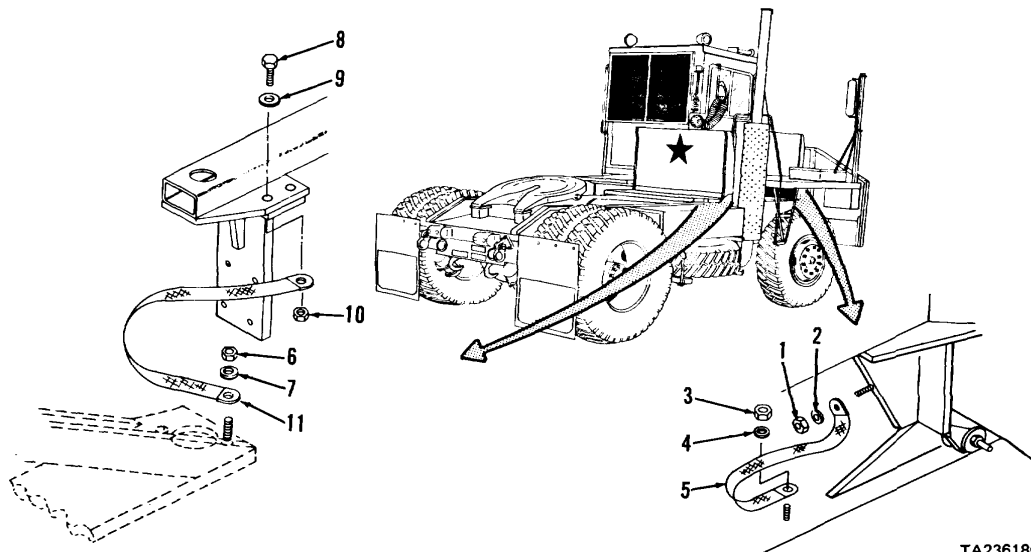

TA236180

2-35. WIRING HARNESS MAINTENANCE (CONT)

e. Ground Straps (cont).

STEP	LOCATION	ITEM	ACTION	REMARKS
NOTE				
Refer to para 2-25b for replacement of the starter-to-air compressor ground strap.				
REMOVAL				
1	Cab deck	a. Nut (1) and washer (2)	Remove	
		b. Ground strap (5)	Disconnect	Remove from cab deck
2	Right hand frame rail	a. Nut (3) and washer (4)	Remove	
		b. Ground strap (5)	Remove	From tractor
		c. Nut (6) and lock washer (7)	Remove	From frame rail stud
		d. Ground strap (11)	Disconnect	From frame rail stud
3	Transmission mount	a. Capscrew (8), washer (9), and locknut (10)	Remove	From right front transmission mount
		b. Ground strap (11)	Remove	From tractor

CLEANING**WARNING**

Dry cleaning solvent (P-D-680), used to clean parts is toxic and flammable. Wear protective goggles and gloves and use only in a well ventilated area. Avoid contact with skin, eyes, and clothes and don't breathe vapors. Do not use near open flame or excessive heat and don't smoke when using it. Failure to do so could cause serious injury. If you become dizzy while using cleaning solvent, get fresh air and medical attention immediately. If contact with skin or clothes is made, flush with large amounts of water. If contact with eyes is made, wash eyes with water and seek medical aid immediately.

Compressed air must not exceed 30 psi. Wear safety glasses when drying parts with compressed air. Failure to do so could cause serious injury to eyes and possible blindness. If you hurt your eyes or if a foreign object is blown into your eyes, seek medical attention immediately.

2-35. WIRING HARNESS MAINTENANCE (CONT)

e. Ground Straps (cont).

STEP	LOCATION	ITEM	ACTION	REMARKS
CLEANING (cont)				
4	All parts	Clean		Use cleaning solvent P-D-680; dry with clean cloths
INSPECTION				
5		a. Ground straps (5 and 11)	Inspect	Replace if cracked, cut, frayed, or corroded
		b. All other parts	Inspect	Replace if cracked, bent, or threads damaged
INSTALLATION				
6	Transmission mount	a. Ground strap (11)	Position	At right front transmission mount
		b. Capscrew (8), washer (9), and locknut (10)	Install and	On transmission mount tighten
7	Right hand frame rail	a. Ground strap (11)	Position	On frame rail stud
		b. Lock washer (7) and nut (6)	Install	
		c. Ground strap (5)	Position	On frame rail stud
		d. Washer (4) and nut (3)	Install and tighten	
8	Cab deck	a. Ground strap (5)	Position	
		b. Washer (2) and nut (1)	Install and tighten	
9	Cab tilt pump	Cab	Lower	To normal operating position
10	Battery box	Battery ground cable	Connect	Para 2-34a

2-35. WIRING HARNESS MAINTENANCE (CONT)

f. Diodes.

This task covers: a. Removal
 b. Cleaning
 c. Inspection/Test
 d. Installation

INITIAL SETUP:

Tools

No. 1 Common Organizational Maintenance
 Tool Kit
 Multimeter

Equipment Condition

Paragraph Condition Description

Vehicle parked on level surface, engine off, and parking brake applied. Key switch off and key removed. Cab tilted 45 degrees.

Materials/Parts

Clean cloths Item 2, Appendix C

Personnel Required

Wheel Vehicle Mechanic MOS 63B

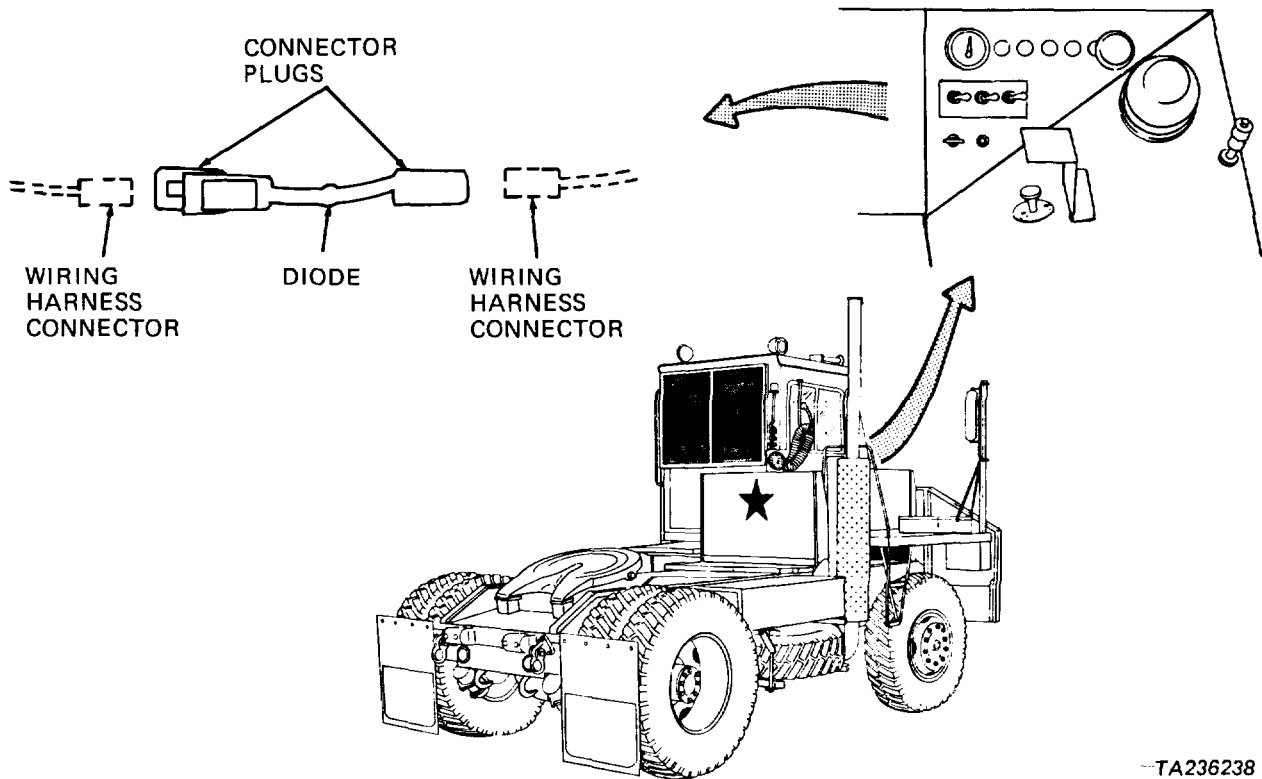

TA236238

2-35. WIRING HARNESS MAINTENANCE (CONT)

f. Diodes (cont).

STEP	LOCATION	ITEM	ACTION	REMARKS
REMOVAL				
1	Right corner instrument panel, underside	Three diodes	Unplug and remove	From wiring harness connectors
CLEANING				
2		Diodes	Clean	Wipe with clean, dry cloth only
INSPECTION/TEST				
3		Diodes	a. Inspect b. Test	Replace as an assembly if insulation frayed, cracked, or cut; conductor broken; or connector plugs damaged a. Set multimeter to X1 ohms range b. Connect multimeter leads to diode connector plugs and note reading c. Reverse multimeter leads and note reading d. Multimeter should indicate high reading for one connection and low reading for other connection. Replace diode as an assembly if readings are both high or both low e. Repeat test above for two remaining diodes
INSTALLATION				
4	Right corner instrument panel, underside	Three diodes	Install	Plug into wiring harness connectors
5	Cab tilt pump	Cab		Lower To normal operating position

2-35. WIRING HARNESS MAINTENANCE (CONT)

g. Circuit Breakers and Fuse.

This task covers: a. Removal c. Installation
 b. Testing

INITIAL SETUP:

Tools

No. 1 Common Organizational Maintenance
 Tool Kit
 Multimeter
 Automotive Mechanic's Tool Kit
 Fuse puller

Equipment Condition

Paragraph	Condition Description
	Vehicle parked on level surface, engine off, and parking brake applied.

Personnel Required

Wheel Vehicle Mechanic MOS 63B

STEP	LOCATION	ITEM	ACTION	REMARKS
REMOVAL				
1	Cab interior, right hand side	a. Fuse (1) b. Circuit breaker (2 thru 8)	Remove Remove	Use fuse puller Pull from fuse block
TESTING				
2		Fuse (1) or circuit breaker (2 thru 8)	Test continuity	Set multimeter to ohmmeter X1 range. Connect a test lead to each side of fuse or circuit breaker. If continuity is not obtained, replace fuse or circuit breaker
INSTALLATION				
3	Cab interior, right hand side	a. Fuse (1) b. Circuit breaker (2 thru 8)	Install Install	Be sure new fuse or circuit breaker has same amperage rating as old fuse or circuit breaker

2-35. WIRING HARNESS MAINTENANCE (CONT)

g. Circuit Breakers and Fuse (cont).

KEY

- 1. Fuse (4A)
- 2. Circuit breaker (6A)
- 3. Circuit breaker (25A)
- 4. Circuit Breaker (25A)
- 5. Circuit breaker (10A)
- 6. Circuit breaker (20A)
- 7. Circuit breaker (20A)
- 8. Circuit breaker (10A)

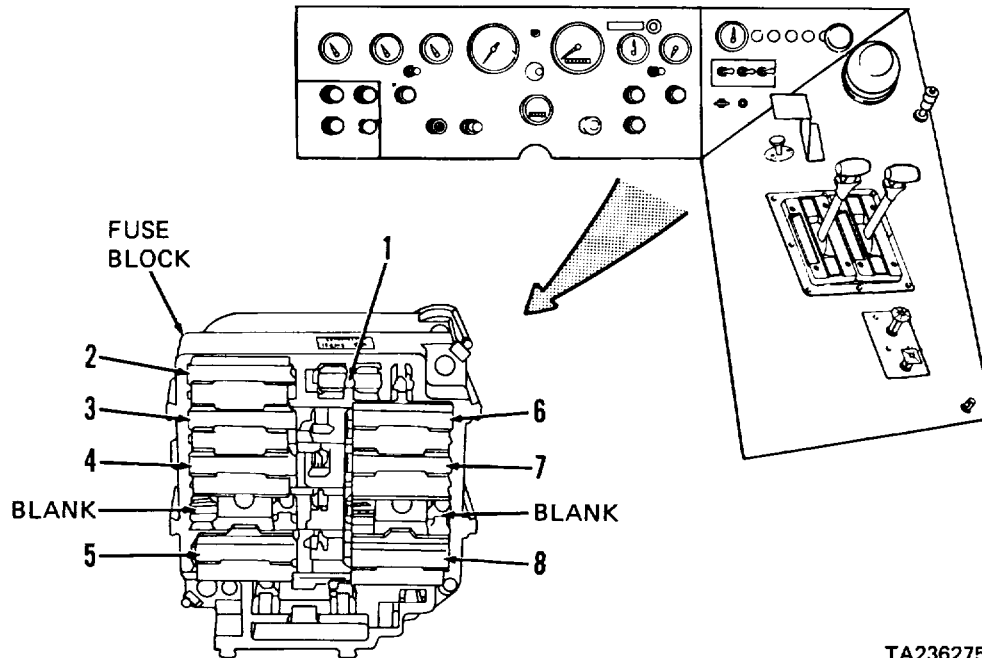

ITEM	CIRCUITS PROTECTED	ITEM	CIRCUITS PROTECTED
1	Gage lights Dash lights	5	FUEL gage and sender TRANS/TORQUE CONVERTER light
2	Windshield washer		Hourmeter
3	Auxiliary trailer lights Warning lights (WATER TEMP and OIL PRESSURE)		OIL PRESSURE gage WATER TEMP gage
	Flood lights 24 Volt inverter switch Backup (rear flood) light switch Low air pressure switch Fan clutch control system	6	Voltmeter Turn signal flasher Service brakes stop light switch
4	Cab heater switch Cab interior light	7	Marker lights Tail lights Trailer lights circuit breakers
		8	Horn

Section VI. POWER TRAIN MAINTENANCE

This section contains the information you need to maintain the:

- Transmission
- Propeller Shaft
- Front Axle
- Rear Axle

It gives you instructions on how to troubleshoot problems, and repair or replace the components that are within the scope of organizational maintenance.

	Para		Para
Troubleshooting Symptom Index.....	2-36	Shift Lockout Cylinder, Lines, and Fittings.....	2-41h
Transmission Troubleshooting	2-37	Shift Lockout Lines and Fittings.....	2-41h(1)
Propeller Shaft Troubleshooting.....	2-38	Shift Lockout Cylinder and Linkage	2-41h(2)
Front Axle Troubleshooting	2-39	Modulator Cable.....	2-41i
Rear Axle Troubleshooting.....	2-40	Transmission Oil Sampling Valve	2-41j
Transmission Maintenance	2-41	Dipstick Tube	2-41k
Servicing Summary Procedure....	2-41a	Propeller Shaft Maintenance.....	2-42
Draining and Refilling		Front Axle Maintenance	2-43
Transmission Fluid	2-41b	Servicing	2-43a
Oil Filter	2-41c	Hub and Drum.....	2-43b
Governor Oil Filter	2-41d	Rear Axle Maintenance.....	2-44
External Oil Filter	2-41e	Servicing	2-44a
Vent Assembly.....	2-41f	Axle Shafts, Hubs, and Drums....	2-44b
Gear Shift Control.....	2-41g		
Gear Shift Control Lever and Cable	2-41g(1)		
Control Mounting Plate.....	2-41g(2)		

2-36. TROUBLESHOOTING SYMPTOM INDEX

	Para/Malfunction	Page
TRANSMISSION		
Transmission leaking fluid	2-37/1	2-420
Transmission fluid dirty	2-37/2	2-421
Transmission fluid smells burned	2-37/3	2-422
Transmission fluid is foamy	2-37/4	2-422
Transmission overheating	2-37/5	2-423
No neutral start or vehicle starts in other than neutral	2-37/6	2-424
Linkage movement not definite; difficulty finding correct gear position	2-37/7	2-424
Vehicle creeps in neutral	2-37/8	2-425
Transmission in wrong gear according to position strip	2-37/9	2-425
No response to shift lever movement	2-37/10	2-425
Slow or erratic shifting	2-37/11	2-425
Rough shifting	2-37/12	2-426
Clutch slippage in all forward gears	2-37/13	2-426
Excessive vibration	2-37/14	2-426
PROPELLER SHAFT		
Excessive noise in propeller shaft	2-38/1	2-427
Excessive vibration in propeller shaft	2-38/2	2-427
FRONT AXLE		
Rapid or uneven tire wear	2-39/1	2-428
Front axle shimmys or vibrates	2-39/2	2-428
Continuous wheel noise	2-39/3	2-428
Hub leaks oil	2-39/4	2-429
REAR AXLE		
Lubricant leaking from differential breather	2-40/1	2-430
Continuous axle or wheel noise	2-40/2	2-430
Differential carrier assembly overheating	2-40/3	2-430
Axle noise when driving	2-40/4	2-431
Hub leaks oil	2-40/5	2-431

2-37. TRANSMISSION TROUBLESHOOTING

**MALFUNCTION
TEST OR INSPECTION
CORRECTIVE ACTION**

1. TRANSMISSION LEAKING FLUID

- Step 1. Check fluid level on transmission dipstick with transmission at operating temperature and engine operating.
- a. If fluid level is above FULL mark, drain (para 2-41b) until fluid level is between FULL and ADD marks.
 - b. If level is not above FULL mark, go to step 2 below.

2-37. TRANSMISSION TROUBLESHOOTING (CONT)

MALFUNCTION
TEST OR INSPECTION
CORRECTIVE ACTION

1. TRANSMISSION LEAKING FLUID (Cont)

- Step 2. Inspect for any worn gaskets or seals on oil pan and dipstick.
- a. Replace any worn gaskets or seals (para 2-41b and 2-41k).
 - b. If gaskets and seals on transmission housing are not worn, go to step 3 below.
- Step 3. Check if vent assembly is clogged or damaged.
- a. Clean or replace vent assembly (para 2-41f).
 - b. If vent assembly is okay, go to step 4 below.
- Step 4. Check for leaks at governor oil filter plug.
- a. If leaks are observed, replace O-ring seal or governor oil filter plug (para 2-41d).
 - b. If leaks are not observed, go to step 5 below.
- Step 5. Check for leaks at transmission oil sampling valve and lines and fittings.
- a. If leaks are observed, tighten fittings (para 2-41j); if hoses are leaking, replace (para 2-41j); if transmission oil sampling valve is leaking, replace (para 2-41j).
 - b. If leaks are not observed, go to step 6 below.
- Step 6. Check for leaks at modulator cable assembly.
- a. If leaks are observed, replace O-ring or modulator cable assembly (para 2-41i).
 - b. If leaks are not observed, notify direct support maintenance.

2. TRANSMISSION FLUID DIRTY

- Step 1. Examine records to determine last time fluid and filters were changed.
- a. If change interval has been excessive, change transmission fluid (para 2-41b) and filters (para 2-41c, 2-41d, and 2-41e).
 - b. If interval has not been excessive, go to step 2 below.

2-37. TRANSMISSION TROUBLESHOOTING (CONT)

MALFUNCTION
TEST OR INSPECTION
CORRECTIVE ACTION

2. TRANSMISSION FLUID DIRTY (Cont)

- Step 2. Examine oil filter for damage.
- a. If oil filter is damaged, replace filter (para 2-41c) and change transmission fluid (para 2-41b).
 - b. If oil filter is not damaged, go to step 3 below.
- Step 3. Operate transmission; TRANS/TORQUE CONVERTER light should be off.
- a. If TRANS/TORQUE CONVERTER light is on, go to Malfunction 5 below.
 - b. If light is not on, notify direct support maintenance.

3. TRANSMISSION FLUID SMELLS BURNED

- Step 1. Check fluid level on transmission dipstick with transmission at operating temperature and engine operating.
- a. If fluid level is above FULL mark, drain (para 2-41b) until fluid level is between FULL and ADD marks.
 - b. If fluid level is below ADD mark, fill (para 2-41b) to FULL mark.
 - c. If fluid level is correct, go to step 2 below.
- Step 2. Operate transmission and check to see if TRANS/TORQUE CONVERTER light is on.
- a. If TRANS/TORQUE CONVERTER light is on, go to Malfunction 5 below.
 - b. If TRANS/TORQUE CONVERTER light is not on, notify direct support maintenance.

4. TRANSMISSION FLUID IS FOAMY

- Step 1. Check fluid level on transmission dipstick with transmission at operating temperature and engine operating.
- a. If fluid level is above FULL mark, drain (para 2-41b) until fluid level is between FULL and ADD marks.
 - b. If fluid level is not above FULL mark, go to step 2 below.

2-37. TRANSMISSION TROUBLESHOOTING (CONT)
--

MALFUNCTION**TEST OR INSPECTION****CORRECTIVE ACTION****4. TRANSMISSION FLUID IS FOAMY (Cont)**

- Step 2. Check source of fluid; ensure that fluid is correct grade and type.
- a. If fluid is not correct grade and type, drain fluid, replace oil filters (para 2-41c, 2-41d, and 2-41e), and add new fluid (para 2-41b).
 - b. If fluid is correct grade and type, go to step 3 below.
- Step 3. Drain fluid, remove oil pan (para 2-41b), and remove oil filter (para 2-41c). Inspect oil filter, oil filter tube, and seal ring for damage.
- a. If items are damaged or seal ring is missing, replace (para 2-41c).
 - b. If items are not damaged and seal ring is not missing, notify direct support maintenance.

5. TRANSMISSION OVERHEATING

- Step 1. Check fluid level on transmission dipstick with transmission at operating temperature and engine operating.
- a. If fluid level is above FULL mark, drain (para 2-41b) until fluid level is between FULL and ADD marks.
 - b. If fluid level is below ADD mark, fill (para 2-41b) to FULL mark.
 - c. If fluid level is between ADD and FULL marks, go to step 2.
- Step 2. Check hoses and fittings between transmission and transmission oil cooler tank for leaks or damage.
- a. If hoses and fittings between transmission and transmission oil cooler tank are leaking or damaged, replace (para 2-41e).
 - b. If hoses and fittings between transmission and transmission oil cooler are not leaking or damaged, go to step 3 below.
- Step 3. Check external oil filter for leaks or damage.
- a. Tighten or replace oil filter (para 2-41e).
 - b. If oil filter is not leaking or damaged, go to step 4 below.

2-37. TRANSMISSION TROUBLESHOOTING (CONT)
--

MALFUNCTION**TEST OR INSPECTION****CORRECTIVE ACTION****5. TRANSMISSION OVERHEATING (Cont)**

Step 4. Remove vent assembly (para 2-41f) and check for damage or clogged condition.

a. Replace vent assembly if damaged; clean if clogged (para 2-41f).

b. If vent assembly is not damaged or clogged, go to step 5 below.

Step 5. Check transmission temperature sending unit.

a. If sending unit is defective, replace (para 2-32d).

b. If sending unit is okay, notify direct support maintenance.

6. NO NEUTRAL START OR VEHICLE STARTS IN OTHER THAN NEUTRAL

Step 1. Check selector linkage to see if it is out of adjustment.

a. If linkage is out of adjustment, adjust (para 2-41g).

b. If linkage is not out of adjustment, go to step 2 below.

Step 2. Check neutral start switch adjustment.

a. If neutral start switch is not positioned properly, adjust (para 2-32e).

b. If neutral start switch is positioned properly, notify direct support maintenance.

7. LINKAGE MOVEMENT NOT DEFINITE; DIFFICULTY FINDING CORRECT GEAR POSITION

Step 1. Check selector linkage to see if it is out of adjustment.

a. If linkage is out of adjustment, adjust (para 2-41g).

b. If linkage is not out of adjustment, go to step 2 below.

Step 2. Check for looseness at nut attaching manual selector shaft to manual selector shaft lever.

a. If nut or manual selector shaft lever are loose, firmly push manual selector shaft onto manual selector shaft lever and tighten nut (para 2-41g).

b. If nut and lever are okay, notify direct support maintenance.

2-37. TRANSMISSION TROUBLESHOOTING (CONT)
--

MALFUNCTION**TEST OR INSPECTION****CORRECTIVE ACTION****8. VEHICLE CREEPS IN NEUTRAL**

Check selector linkage to see if it is out of adjustment.

- a. If linkage is out of adjustment, adjust (para 2-41g).
- b. If linkage is okay, notify direct support maintenance.

9. TRANSMISSION IN WRONG GEAR ACCORDING TO POSITION STRIP

Check selector linkage to see if it is out of adjustment.

- a. If linkage is out of adjustment, adjust (para 2-41g).
- b. If linkage is not out of adjustment, notify direct support maintenance.

10. NO RESPONSE TO SHIFT LEVER MOVEMENT

Step 1. Check to see if selector linkage is disconnected.

- a. If linkage is disconnected, connect and adjust (para 2-41g).
- b. If linkage is not disconnected, go to step 2 below.

Step 2. Check to see if selector linkage is damaged or broken.

- a. If selector linkage is damaged or broken, repair or replace (para 2-41g).
- b. If linkage is okay, notify direct support maintenance.

11. SLOW OR ERRATIC SHIFTING

Step 1. Remove vent assembly (para 2-41f) and check if dirty or damaged.

- a. If vent assembly is dirty, clean; if damaged, replace (para 2-41f).
- b. If vent assembly is not dirty or damaged, go to step 2 below.

Step 2. Check transmission linkage for proper adjustment or damage.

- a. If linkage is not properly adjusted, adjust (para 2-41g); replace any damaged parts (para 2-41g).
- b. If linkage is okay, notify direct support maintenance.

2-37. TRANSMISSION TROUBLESHOOTING (CONT)**MALFUNCTION****TEST OR INSPECTION****CORRECTIVE ACTION****12. ROUGH SHIFTING**

- Step 1. Check transmission linkage for proper adjustment or damage.
- a. If linkage is not properly adjusted, adjust (para 2-41g); replace any damaged parts (para 2-41g).
 - b. If linkage is properly adjusted and there is no damage, go to step 2 below.
- Step 2. Check if modulator cable is kinked or out of adjustment.
- a. If kinked, replace (para 2-13e); if out of adjustment, adjust (para 2-13e).
 - b. If modulator cable is not kinked or out of adjustment, notify direct support maintenance.

13. CLUTCH SLIPPAGE IN ALL FORWARD GEARS

Check fluid level on transmission dipstick with transmission at operating temperature and engine operating.

- a. If fluid level is below ADD mark, add fluid (para 2-41b).
- b. If fluid level is at FULL mark, notify direct support maintenance.

14. EXCESSIVE VIBRATION

Examine propeller shaft for out-of-phase condition.

- a. If propeller shaft is out of phase, disconnect, rotate to correct phase and reconnect (para 2-42).
- b. If propeller shaft is not out of phase, notify direct support maintenance.

2-38. PROPELLER SHAFT TROUBLESHOOTING**MALFUNCTION****TEST OR INSPECTION****CORRECTIVE ACTION****1. EXCESSIVE NOISE IN PROPELLER SHAFT**

- Step 1. Check propeller shaft for insufficient lubrication, wear or damage (indicated by excessive movement between universal joint and propeller shaft in any one direction).
- a. If propeller shaft is insufficiently lubricated, lubricate (para 2-42); if worn or damaged, repair or replace propeller shaft (para 2-42).
 - b. If propeller shaft is lubricated and not worn or damaged, go to step 2 below.
- Step 2. Check for bent propeller shaft.
- a. If propeller shaft is bent, replace (para 2-42).
 - b. If propeller shaft is not bent, go to step 3 below.
- Step 3. Check splines on sleeve tube and splined shaft for wear or damage.
- a. If splines are worn or damaged, replace sleeve tube and splined shaft (para 2-42).
 - b. If splines are not worn or damaged, notify direct support maintenance.

2. EXCESSIVE VIBRATION IN PROPELLER SHAFT

- Step 1. Check propeller shaft for bent or sprung condition.
- a. If propeller shaft is bent or sprung, replace (para 2-42).
 - b. If propeller shaft is not bent or sprung, go to step 2 below.
- Step 2. Check universal joint for wear or damage by checking for movement between universal joint and propeller shaft.
- a. If movement is observed between universal joint and propeller shaft, replace propeller shaft (para 2-42).
 - b. If movement is not observed, notify direct support maintenance.

2-39. FRONT AXLE TROUBLESHOOTING**MALFUNCTION****TEST OR INSPECTION****CORRECTIVE ACTION****1. RAPID OR UNEVEN TIRE WEAR**

Check that tires are inflated to 120 psi.

- a. If tires are not inflated to 120 psi, inflate to 120 psi.
- b. If tires are inflated to 120 psi, notify direct support maintenance.

2. FRONT AXLE SHIMMYS OR VIBRATES

Check shock absorbers for wear.

- a. If shock absorbers are worn, replace (para 2-64).
- b. If shock absorbers are not worn, notify direct support maintenance.

3. CONTINUOUS WHEEL NOISE

Step 1. Check front wheel lug nuts for looseness.

- a. If lug nuts are loose, tighten (para 2-57).
- b. If lug nuts are tight, go to step 2 below.

Step 2. Check front axle hubs for proper lubrication.

- a. If front axle hubs are not lubricated, lubricate (para 2-43a).
- b. If front axle hubs are lubricated, go to step 3 below.

Step 3. Check wheel bearings for proper adjustment (raise wheel and use pry bar to check for any noticeable end play); repeat for other wheel.

- a. If end play is noticeable, adjust or replace wheel bearings (para 2-43b).
- b. If end play is not noticeable, go to step 4 below.

Step 4. Remove wheel (para 2-43b), clean bearings (para 2-43b), and inspect bearings (para 2-43b) for damage or wear.

- a. If bearings are damaged or worn, replace (para 2-43b).
- b. If bearings are okay, reinstall and lubricate (para 2-43b). Then notify direct support maintenance.

2-39. FRONT AXLE TROUBLESHOOTING (CONT)**MALFUNCTION****TEST OR INSPECTION****CORRECTIVE ACTION****4. HUB LEAKS OIL**

Step 1. Check for oil leaks from front axle brake drums.

a. If leaks are observed from brake drum, replace oil seal (para 2-43b) and oil-contaminated brake shoes (para 2-50a).

b. If leaks are not observed from brake drums, go to step 2 below.

Step 2. Check for leaks at front axle hub cap assembly.

a. If leaks are observed at center of hub cap assembly, replace rubber plug (para 2-43a).

b. If leaks are observed around circumference of hub cap assembly, replace gasket (para 2-43b). If leaks are still observed with new gasket, replace hub cap assembly (para 2-43a).

2-40. REAR AXLE TROUBLESHOOTING**MALFUNCTION****TEST OR INSPECTION****CORRECTIVE ACTION****1. LUBRICANT LEAKING FROM DIFFERENTIAL BREATHER**

Check lubricant level.

Drain to proper level (para 2-44a).

2. CONTINUOUS AXLE OR WHEEL NOISE

Step 1. Check rear wheel lug nuts for looseness.

a. If lug nuts are loose, tighten (para 2-57).

b. If lug nuts are tight, go to step 2 below.

Step 2. Check lubricant level.

a. If lubricant level is below level plug opening, add lubricant (para 2-44a).

b. If lubricant level is at level plug opening, go to step 3 below.

Step 3. Check wheel bearings for proper adjustment (raise wheel and use pry bar to check for any noticeable end play) or damage. Repeat for other wheels.

a. If end play is noticeable, adjust or replace wheel bearings (para 2-44b).

b. If end play is not noticeable, go to step 4 below.

Step 4. Check axle shafts for damage.

a. If axle shafts are damaged, replace (para 2-44b).

b. If axle shafts are not damaged, notify direct support maintenance.

3. DIFFERENTIAL CARRIER ASSEMBLY OVERHEATING

Check lubricant level.

a. If lubricant level is below level plug opening, add lubricant (para 2-44a).

b. If lubricant level is at level plug opening, notify direct support maintenance.

2-40. REAR AXLE TROUBLESHOOTING (CONT)**MALFUNCTION****TEST OR INSPECTION****CORRECTIVE ACTION****4. AXLE NOISE WHEN DRIVING**

Check lubricant level.

- a. If lubricant level is below level plug opening, add lubricant (para 2-44a).
- b. If lubricant level is at level plug opening, notify direct support maintenance.

5. HUB LEAKS OIL

Step 1. Check for oil leaks from rear axle brake drums.

- a. If leaks are observed from brake drum, replace oil seal and oil-contaminated brake shoes (para 2-44b).
- b. If leaks are not observed from brake drums, go to step 2 below.

Step 2. Check for oil leaks at axle shaft flange gasket.

- a. If oil leaks are observed, replace axle shaft flange gasket (para 2-44b).
- b. If oil leaks are still observed with new gasket, replace defective axle shaft or hub (para 2-44b).

2-41. TRANSMISSION MAINTENANCE

a. Servicing (Summary Procedure).

INITIAL SETUPTools

No. 1 Common Organizational Maintenance

Tool Kit

Adjustable open end wrench
 Combination wrench set
 Socket wrench set
 Torque wrench
 Strap type filter wrench

Materials/Parts

Cleaning solvent	Item 1, Appendix C
Clean cloths	Item 2, Appendix C
Transmission fluid	Item 8, Appendix C
Mineral spirits	Item 33, Appendix C
Grease	FSCM 41625 PN B300156
Sump filter kit	FSCM 73342 PN 6882787
Seal ring	FSCM 73342 PN 6762127
Governor oil filter kit	FSCM 73342 PN 6884749
External oil filter element	FSCM 70040 PN PF897

Personnel Required

Wheel Vehicle Mechanic MOS 63B

List of Tasks

Task No.	Task	Task Ref.	Troubleshooting Ref. No. (Para)
1.	Maintain dipstick level	2-41b	2-37
2.	Sample transmission oil	2-41j	2-37
3.	Drain and refill transmission oil	2-41b	2-37
4.	Replace sump filter	2-41c	2-37
5.	Replace governor oil filter	2-41d	2-37
6.	Replace external oil filter element	2-41e	2-37
7.	Lubricate modulator cable	2-41i	2-37
8.	Lubricate gear shift cable	2-41g(1)	2-37

2-41. TRANSMISSION MAINTENANCE (CONT)

b. Draining and Refilling Transmission Fluid.

This task covers draining and refilling of transmission fluid.

INITIAL SETUP

Tools

No. 1 Common Organizational Maintenance

Tool Kit

- Socket wrench set, 1/2 inch drive
- Socket wrench handle, 1/2 inch drive
- Torque wrench, 1/2 inch drive,
175 pounds foot

Five gallon container

Materials/Parts

Clean cloths	Item 2, Appendix C	2-65c
Transmission fluid	Item 8, Appendix C	2-41k
Oil filter and gasket kit	FSCM 73342 PN 6882787	

Equipment Condition

Paragraph Condition Description

Engine operated for 15 minutes immediately prior to draining fluid. Shift transmission to neutral.

Parked on level surface; parking brake applied; engine off. Rear platform removed.

Transmission dipstick tube removed (for pan removal only)

Personnel Required

Wheel Vehicle Mechanic MOS 63B

KEY

1. Oil pan drain plug
2. Drain plug washer
3. Capscrews (21)
4. Transmission oil pan
5. Oil pan gasket

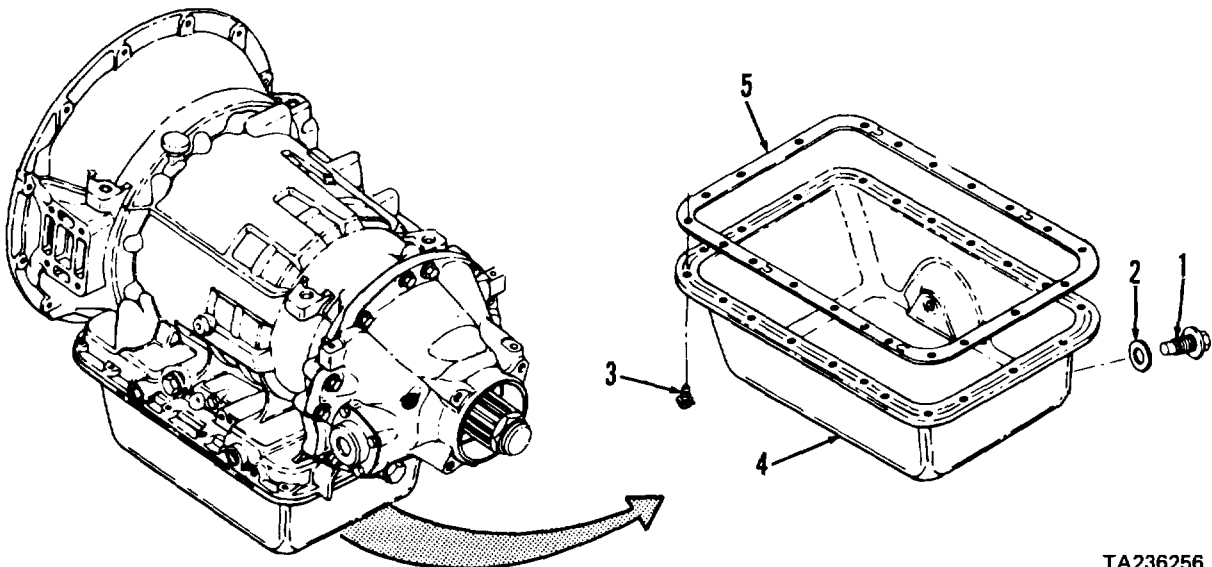

TA236256

2-41. TRANSMISSION MAINTENANCE (CONT)

b. Draining and Refilling Transmission Fluid.

STEP	LOCATION	ITEM	ACTION	REMARKS
1 container	Transmis- sion	a. Oil pan drain plug (1) and drain plug washer (2)		Remove Position 5 gallon under oil pan drain plug (1) before removing
		b. Transmission fluid	Drain	
		c. Oil pan drain plug (1) and drain plug washer (2)	Install	Tighten to 15-20 pounds foot torque
		d. 21 capscrews (3)	Remove	
		e. Transmission oil pan (4) and oil pan gasket (5)	Remove	Discard oil pan gasket (5). Clean transmission oil pan (4). Examine for any damage. Straighten gasket flange if necessary. Replace if necessary

NOTE

Examine transmission fluid and transmission oil pan (4) for evidence of metal particles or engine coolant. These indicate damage to the transmission. Disassembly, inspection, and cleaning of the transmission is recommended.

		f. Oil filter	Remove and replace	Para 2-41c
		g. Governor oil filter	Remove and replace	Para 2-41d
2	Transmis- sion cooler line	External oil filter	Remove and replace	Para 2-41e
3	Transmis- sion oil pan (4)	New oil pan gasket (5)	Position	On transmission oil pan (4). Don't use gasket retainer or adhesive
4	Transmis- sion bottom	a. Transmission oil pan (4) and new oil pan gasket (5)	Position	Against transmission bottom

2-41. TRANSMISSION MAINTENANCE (CONT)

b. Draining and Refilling Transmission Fluid.

STEP	LOCATION	ITEM	ACTION	REMARKS
4 (cont)		b. Capscrews (3)	Install	Install four capscrews (3) through corners of transmission oil pan (4). Hand tighten. Then completely install 17 remaining capscrews (3) by hand. Alternately tighten capscrews 180 degrees apart to 5 pounds foot torque. Repeat process, tightening to 10-15 pounds foot
		c. Transmission dipstick tube	Install	Para 2-41k
5	Dipstick tube	a. 15 U.S. quarts transmission fluid	Pour	Pour 21 quarts only if torque converter is empty
		b. Transmission	a. Check fluid level	Start engine and shift transmission through all ranges. Shift to neutral. Run engine for one minute at 1000-1200 rpm; then idle engine. Insert and remove dipstick with engine idling to check level. Add fluid if necessary to bring fluid level to ADD mark on dipstick
			b. Recheck	Operate tractor until engine coolant reaches 170 degrees and repeat level check above. Add fluid if necessary to bring fluid level to FULL mark on dipstick
6	Tractor, rear	Rear platform	Install	Para 2-65c

2-41. TRANSMISSION MAINTENANCE (CONT)

c. Oil Filter. This task covers removal and installation.

INITIAL SETUP

Tools

- No. 1 Common Organizational Maintenance Tool Kit
- Socket wrench set, 1/2 inch drive
- Socket wrench handle, 1/2 inch drive
- Torque wrench, 1/2 inch drive, 175 pounds foot

Personnel Required

Wheel Vehicle Mechanic MOS 63B

Equipment Condition

Paragraph Condition Description

Parked on level surface; parking brake applied; engine off. Transmission fluid drained and oil pan removed.

Materials/Parts

- | | |
|--------------------|-----------------------|
| Transmission fluid | 2-41b |
| Oil filter | Item 8, Appendix C |
| Seal ring | FSCM 73342 PN 6883044 |
| | FSCM 73342 PN 6762127 |

KEY

1. Capscrew
2. Oil filter
3. Oil filter tube
4. Seal ring

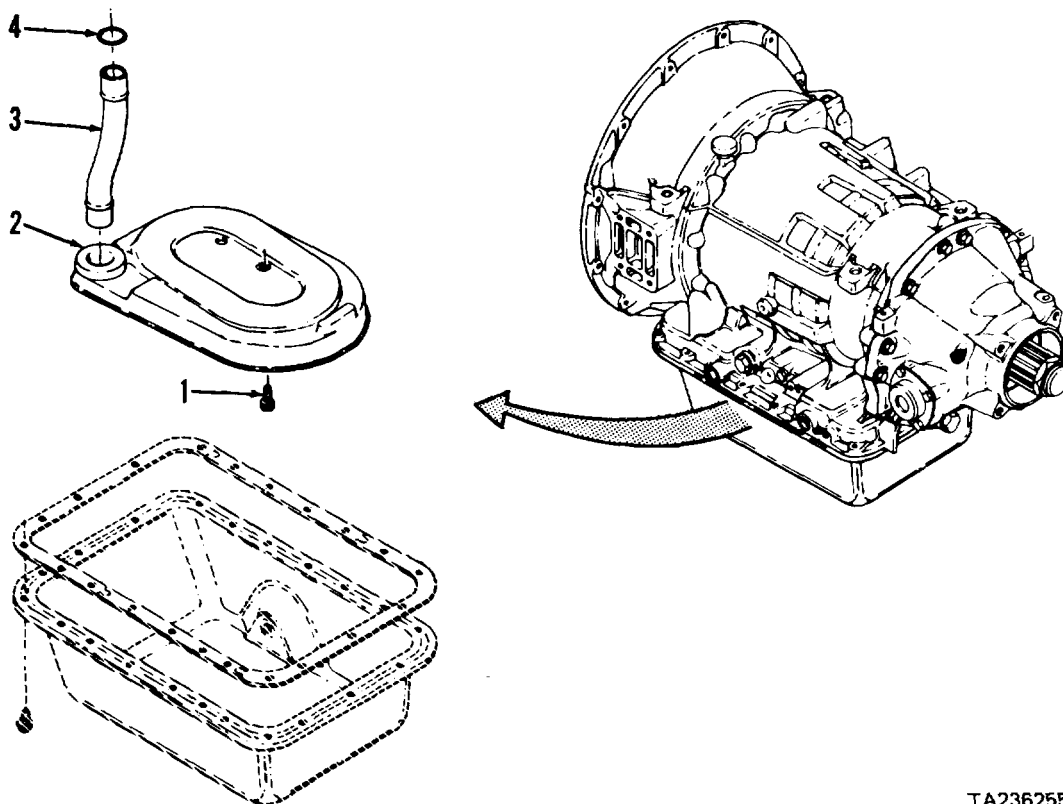

TA236255

2-41. TRANSMISSION MAINTENANCE (CONT)

c. Oil Filter. This task covers removal and installation.

STEP	LOCATION	ITEM	ACTION	REMARKS
REMOVAL				
1	Transmis- sion	a. Capscrew (1) b. Oil filter (2) and oil filter tube (3)	Remove Remove	Discard oil filter (2). Examine oil filter tube (3) for any damage. Replace if necessary
2	Oil filter tube (3)	Seal ring (4)	Remove	Discard
INSTALLATION				
3	Oil filter tube (3)	New seal ring (4)	Install	Lubricate with transmission fluid
4	New oil filter (2)	Oil filter tube (3)	Install	Insert end away from seal ring (4) into new oil filter (2)
5	Transmis- sion	a. New oil filter (2) and oil filter tube (3) b. Capscrew (1) c. Oil pan and gasket d. Transmission dipstick tube e. Transmission fluid	Position Install Install Install Add and check level	Insert end of oil filter tube (3) with seal ring (4) into hole in trans- mission Tighten to 10-15 pounds foot torque Para 2-41b Para 2-41k Para 2-41b

2-41. TRANSMISSION MAINTENANCE (CONT)

d. Governor Oil Filter. This task covers removal and installation.

INITIAL SETUP

Tools

No. 1 Common Organizational Maintenance

Tool Kit

- Socket wrench set, 1/2 inch drive
- Socket wrench handle, 1/2 inch drive

Materials/Parts

Transmission fluid Item 8, Appendix C

Governor filter

kit FSCM 73342 PN 6884749

Personnel Required

Wheel Vehicle Mechanic MOS 63B

Equipment Condition

Paragraph	Condition Description
-----------	-----------------------

2-41b	Parked on level surface; parking brake applied; engine off. Transmission fluid drained.
-------	--

KEY

1. Plug
2. O-ring seal
3. Governor filter

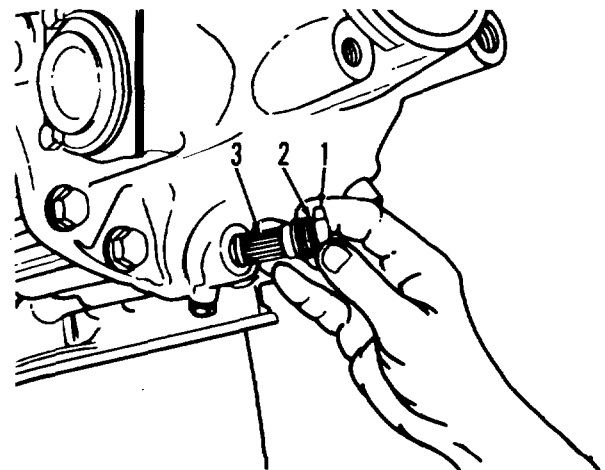
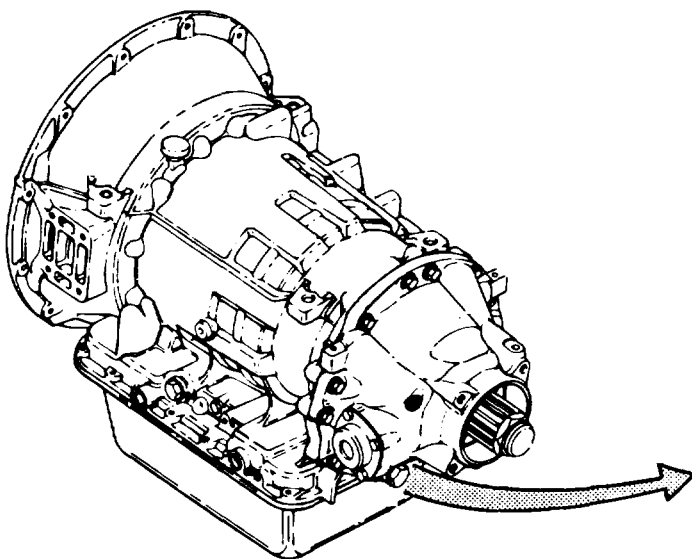

TA236028

2-41. TRANSMISSION MAINTENANCE (CONT)

d. Governor Oil Filter. This task covers removal and installation.

STEP	LOCATION	ITEM	ACTION	REMARKS
REMOVAL				
1	Rear cover assembly	a. Plug (1) and O-ring seal (2)	Remove	Discard O-ring seal (2). Discard plug (1) if threads are damaged
		b. Governor filter (3)	Remove	Discard
INSTALLATION				
2	Rear cover assembly	a. New governor filter (3)	Position	Open end first
		b. Plug (1) and new O-ring seal (2)	Install	Lubricate O-ring seal (2) with transmission fluid. Install plug (1) tight enough to prevent leakage
3	Transmission	Oil pan and gasket	Install	Para 2-41b
4	Transmission dipstick tube	Transmission fluid	Add and check level	Para 2-41b

2-41. TRANSMISSION MAINTENANCE (CONT)

e. External Oil Filter.

- This task covers:
- a. Servicing
 - b. Removal
 - c. Cleaning
 - d. Inspection
 - e. Installation

INITIAL SETUP

Tools

- No. 1 Common Organizational Maintenance Tool Kit
 - Automotive electrical tool kit
 - Socket wrench set
 - Socket wrench extension
 - Socket wrench handle
 - Knife
 - Scratch wire brush
 - Safety glasses
 - Strap type filter wrench
 - One gallon container
 - Mandrel assembly tool
 - FSCM 00624 PN 1582-8

- Hydraulic oil
- Detergent
- Filter element
- Nine tie straps
- Two O-rings
- Item 22, Appendix C
- Item 27, Appendix C
- FSCM 70040 PN PF897
- FSCM 96906 PN MS3667-1-9
- FSCM 90915 PN 97140175

Personnel Required
Wheel Vehicle Mechanic MOS 63B

References
LO 9-2320-285-12
(M878A1 Lubrication Order)

Materials/Parts

- Cleaning solvent
- Clean cloths
- Transmission fluid
- Tags
- Item 1, Appendix C
- Item 2, Appendix C
- Item 8, Appendix C
- Item 14, Appendix C

Equipment Condition

- | | |
|-----------|---|
| Paragraph | Condition Description |
| | Parked on level surface; parking brake applied; engine off. |
| 2-65c | Rear platform removed. |

STEP	LOCATION	ITEM	ACTION	REMARKS
------	----------	------	--------	---------

SERVICING

WARNING

Dry cleaning solvent (P-D-680), used to clean parts is toxic and flammable. Wear protective goggles and gloves and use only in a well ventilated area. Avoid contact with skin, eyes, and clothes and don't breathe vapors. Do not use near open flame or excessive heat and don't smoke when using it. Failure to do so could cause serious injury. If you become dizzy while using cleaning solvent, get fresh air and medical attention immediately. If contact with skin or clothes is made, flush with large amounts of water. If contact with eyes is made, wash eyes with water and seek medical aid immediately.

2-41. TRANSMISSION MAINTENANCE (CONT)

e. External Oil Filter (cont).

KEY

- 1. Filter element
- 2. Fitting
- 3. Hose
- 4. Fitting
- 5. Hose
- 6. Locknuts (3)
- 7. Capscrews (3)
- 8. Filter head
- 9. Elbow

- 32. Adapter
- 33. Reducer bushing
- 34. Fitting
- 35. Adapter
- 36. Tee
- 37. Nipple
- 38. Fitting
- 39. O-ring

- 10. Adapter
- 11. Elbow
- 12. Tie straps (10)
- 13. Protective hose
- 14. Nut
- 15. Lock washer
- 16. Clamp
- 17. Fitting
- 18. Adapter
- 19. Fitting
- 20. Hose
- 21. Adapter
- 22. Nut
- 23. Oil temperature sender switch

- 24. Reducer bushing
- 25. Fitting
- 26. Adapter
- 27. Tee
- 28. Adapter
- 29. O-ring
- 30. Adapter
- 31. Tee

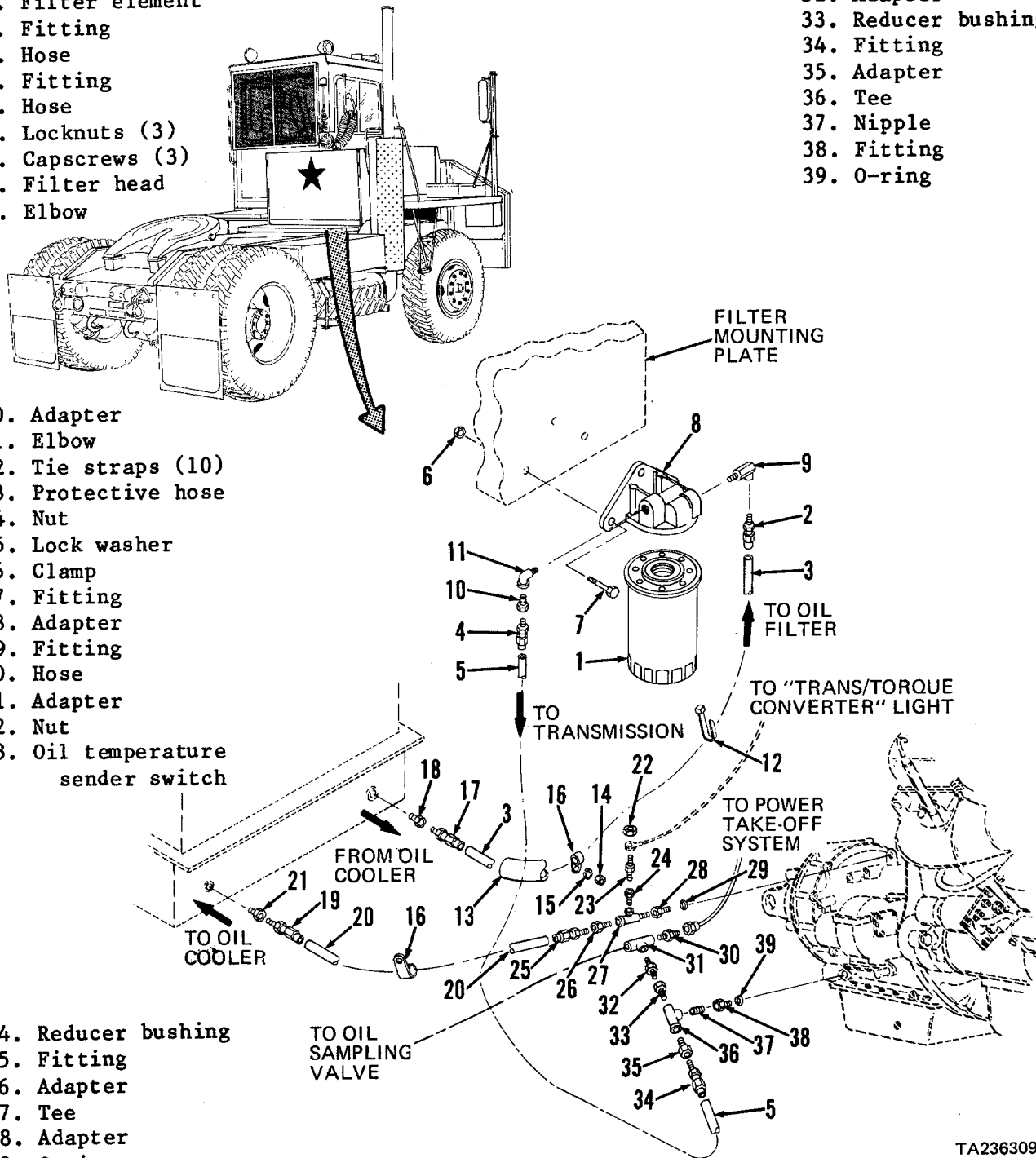

TA236309

2-41. TRANSMISSION MAINTENANCE (CONT)

e. External Oil Filter (cont).

STEP	LOCATION	ITEM	ACTION	REMARKS
SERVICING (cont)				
1	Cab guard, filter mounting plate	a. Filter element (1)	Clean	Use clean cloth moistened with cleaning solvent P-D-680; dry using clean cloth
		b. One gallon container	Position	Under filter element (1) to drain oil into
		c. Filter element (1)	Remove and discard	Use clamping type filter wrench; turn counterclockwise to remove
		d. New filter element (1)	a. Apply clean transmission oil to gasket b. Install	Hand tighten
		e. One gallon container	Remove	
		f. Transmission fluid	Add and check level	Para 2-41b

WARNING

Dry cleaning solvent (P-D-680), used to clean parts is toxic and flammable. Wear protective goggles and gloves and use only in a well ventilated area. Avoid contact with skin, eyes, and clothes and don't breathe vapors. Do not use near open flame or excessive heat and don't smoke when using it. Failure to do so could cause serious injury. If you become dizzy while using cleaning solvent, get fresh air and medical attention immediately. If contact with skin or clothes is made, flush with large amounts of water. If contact with eyes is made, wash eyes with water and seek medical aid immediately.

REMOVAL

2	Cab guard, filter mounting plate	a. Filter element (1)	Clean	Use clean cloth moistened with cleaning solvent P-D-680; dry using clean cloth
		b. One gallon container	Position	Under filter element (1) to drain oil into
		c. Filter element (1)	Remove and discard	Use clamping type filter wrench; turn counterclockwise to remove
		d. One gallon container	Remove	Discard oil

2-41. TRANSMISSION MAINTENANCE (CONT)

e. External Oil Filter (cont).

STEP	LOCATION	ITEM	ACTION	REMARKS
REMOVAL (cont)				
2 (cont)			NOTE Tag and identify all hoses before removing to aid in installation.	
		e. Fitting (2)	Loosen and disconnect	From elbow (9)
		f. Fitting (4)	Loosen and disconnect	From adapter (10)
		g. Three locknuts (6) and cap-screws (7)	Remove	Support filter head (8)
		h. Filter head (8)	Remove	
3	Filter head (8)	a. Elbow (9)	Remove	From filter head (8)
		b. Adapter (10)	Remove	From elbow (11)
		c. Elbow (11)	Remove	From filter head (8)
4	Vehicle, right side	a. Ten tie straps (12)	Cut, remove, and discard	
		b. Protective hose (13)	Remove	
		c. Nut (14), lock washer (15), and clamp (16)	Remove	
5	Radiator, bottom	a. Container	Position	Under oil cooler lines at radiator
		b. Fitting (17)	Loosen and disconnect	
		c. Hose (3)	Remove	From vehicle
		d. Adapter (18)	Remove	
		e. Fitting (19)	Loosen and disconnect	
		f. Adapter (21)	Remove	
6	Transmission, right side	a. Nut (22)	Remove	Disconnect wire lead
		b. Oil temperature sender switch (23)	Remove	

2-41. TRANSMISSION MAINTENANCE (CONT)

e. External Oil Filter (cont).

STEP	LOCATION	ITEM	ACTION	REMARKS
REMOVAL (cont)				
6 (cont)		c. Reducer bushing (24)	Remove	
		d. Fitting (25)	Loosen and disconnect	
		e. Hose (20)	Remove	From vehicle
		f. Adapter (26)	Remove	
		g. Tee (27)	Remove	
		h. Adapter (28) and O-ring (29)	Remove	Discard O-ring (29)
		i. Oil sampling valve hose	Loosen and disconnect	Para 2-41j
		j. Exhaust heat shield	Remove	Para 2-14a
		k. Power take-off hose	Loosen and disconnect	
		l. Adapter (30)	Remove	
		m. Tee (31)	Remove	
		n. Adapter (32)	Remove	
		o. Reducer bushing (33)	Remove	
		p. Fitting (34)	Loosen and disconnect	
		q. Hose (5)	Remove	From vehicle
		r. Adapter (35)	Remove	
		s. Tee (36)	Remove	
		t. Nipple (37)	Remove	
	u. Fitting (38) and O-ring (39)	Remove	Discard O-ring (39)	
CLEANING				
7		a. Hoses (3, 5, and 20)	Clean	Use clean cloth moistened with detergent; dry using clean cloths
		b. Oil temperature sender switch (23)	Clean	Wipe with clean dry cloth

2-41. TRANSMISSION MAINTENANCE (CONT)

e. External Oil Filter (cont).

STEP	LOCATION	ITEM	ACTION	REMARKS
------	----------	------	--------	---------

CLEANING (cont)

7
(cont)

WARNING

Dry cleaning solvent (P-D-680), used to clean parts is toxic and flammable. Wear protective goggles and gloves and use only in a well ventilated area. Avoid contact with skin, eyes, and clothes and don't breathe vapors. Do not use near open flame or excessive heat and don't smoke when using it. Failure to do so could cause serious injury. If you become dizzy while using cleaning solvent, get fresh air and medical attention immediately. If contact with skin or clothes is made, flush with large amounts of water. If contact with eyes is made, wash eyes with water and seek medical aid immediately.

c. Remaining parts	Clean	Use cleaning solvent P-D-680; dry using clean cloths
--------------------	-------	--

INSPECTION

8

a. Hoses (3, 5, and 20)	Inspect for cracks wear chafing blockage	Replace if defects observed; refer to repair procedures below for replacement
b. Fittings (2, 4, 17, 19, 25, and 34)	Inspect for cracks breaks damaged threads distortion	Replace if defects observed; refer to repair procedures below for replacement
c. Oil temperature sender switch (23)	Inspect for cracks loose or damaged terminal damaged threads	Replace if defects observed
d. Remaining parts	Inspect for cracks breaks distortion damaged threads	Replace if defects observed

2-41. TRANSMISSION MAINTENANCE (CONT)

e. External Oil Filter (cont).

STEP	LOCATION	ITEM	ACTION	REMARKS
------	----------	------	--------	---------

REPAIR

CAUTION

If fittings (2, 4, 17, 19, 25 and/or 34) require replacement, discard hose (3, 5, or 20). If hose is reused, oil leakage could occur causing damage to transmission.

9	Hose (3, 5, or 20)	a. Fitting	Place fitting socket in vise as shown	
		b. Mandrel assembly tool	Install in fitting nipple; tighten nut of fitting. Turn tool counterclockwise to remove fitting nipple and nut	
		c. Hose	Turn hose clockwise out of fitting socket; discard hose	

NOTE

Repeat step 9 above to remove remaining fittings from hose(s).

WARNING

Dry cleaning solvent (P-D-680), used to clean parts is toxic and flammable. Wear protective goggles and gloves and use only in a well ventilated area. Avoid contact with skin, eyes, and clothes and don't breathe vapors. Do not use near open flame or excessive heat and don't smoke when using it. Failure to do so could cause serious injury. If you become dizzy while using cleaning solvent, get fresh air and medical attention immediately. If contact with skin or clothes is made, flush with large amounts of water. If contact with eyes is made, wash eyes with water and seek medical aid immediately.

10		Fittings	Clean	Use cleaning solvent P-D-680; allow to air dry. Use wire brush to remove all hose residue from socket and/or nipple of fittings
11	Hose	a. Hose	Cut to proper length	Use new hose; use old hose for determining length required. Cut hose square using fine tooth hacksaw
		b. Fitting	Place fitting socket in vise as shown	

2-41. TRANSMISSION MAINTENANCE (CONT)

e. External Oil Filter (cont).

STEP	LOCATION	ITEM	ACTION	REMARKS
REPAIR (cont)				
11 (cont)		c. Hose	Screw hose counterclockwise into socket until hose bottoms; back hose off 1/4 to 1/2 turn	
		d. Mandrel assembly tool	Oil nipple threads, mandrel assembly tool, and inside of hose liberally using hydraulic oil. Tighten fitting nipple and nut on mandrel assembly tool. Apply oil to all parts	
		e. Fitting	Screw nipple clockwise into socket and hose. Tighten nipple until snug against socket. Remove fitting from vise	

NOTE

Repeat steps b thru e above to install remaining fittings on hose(s).

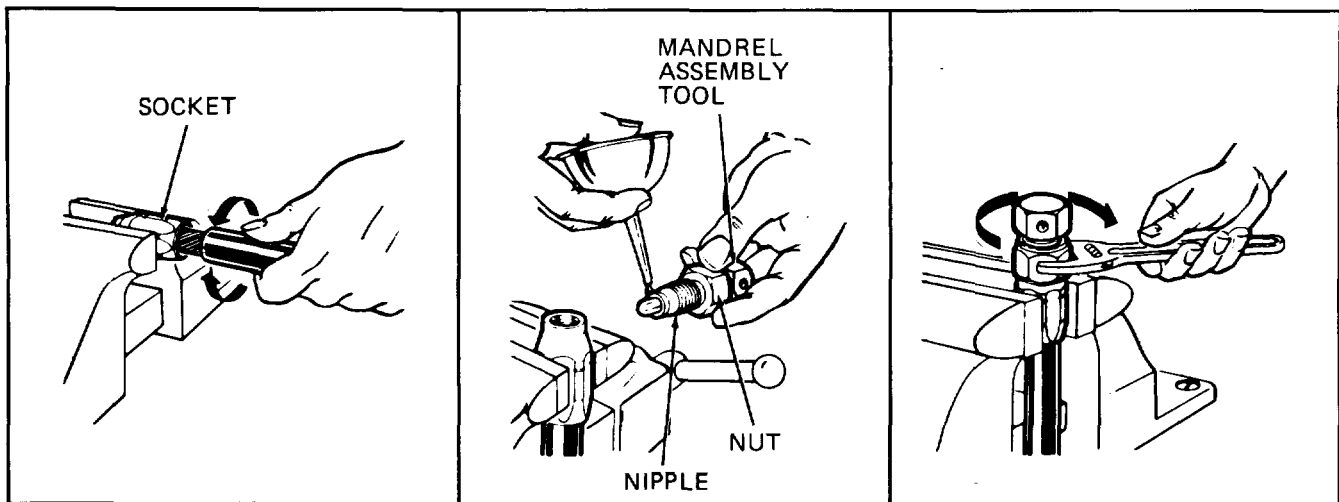

TA236149

INSTALLATION

12	Transmission, right side	a. New O-ring (39) and fitting (38)	Install	In transmission port
		b. Nipple (37)	Install	In fitting (38)
		c. Tee (36)	Install	On nipple (37)
		d. Adapter (35)	Install	In tee (36)
		e. Hose (5)	Route	Between adapter (35) and filter mounting plate

2-41. TRANSMISSION MAINTENANCE (CONT)

e. External Oil Filter (cont).

STEP	LOCATION	ITEM	ACTION	REMARKS		
INSTALLATION (cont)						
12 (cont)		f. Fitting (34) tighten	Connect and	To adapter (35)		
		g. Reducer bushing (33)	Install	In tee (36)		
		h. Adapter (32)	Install	In reducer bushing (33)		
		i. Tee (31)	Install	In adapter (32)		
		j. Adapter (30)	Install	In tee (31)		
		k. Power take-off hose	Connect and tighten	To adapter (30)		
		l. Exhaust heat shield	Install	Para 2-14a		
		m. Oil sampling valve hose	Connect and tighten	Para 2-41j		
		n. New O-ring (29) and adapter (28)	Install	In transmission port		
		o. Tee (27)	Install	In adapter (28)		
		p. Adapter (26)	Install	In tee (27)		
		q. Hose (20) cooler	Route	Between adapter (26) and oil		
		r. Fitting (25) tighten	Connect and	To adapter (26)		
		s. Reducer bushing (24)	Install	In tee (27)		
		t. Oil temperature sender switch (23)	Install and connect wire lead	In reducer bushing (24)		
		u. Nut (22)	Install and tighten			
		13	Radiator, bottom	a. Adapter (21)	Install	In radiator port
				b. Hose (20)	Route	To adapter (21)
				c. Fitting (19)	Connect and tighten	To adapter (21)
d. Adapter (18)	Install			In radiator port		
e. Hose (3)	Route			Between adapter (18) and filter mounting plate		
f. Fitting (17)	Connect and tighten			To adapter (18)		
g. Clamp (16)	Position			On hoses (3 and 20) and on vehicle frame		
h. Lock washer (15) and nut (14)	Install			Secure clamp (16)		
i. Protective hose (13)	Install			Around hoses (3 and 20)		

2-41. TRANSMISSION MAINTENANCE (CONT)

e. External Oil Filter (cont).

STEP	LOCATION	ITEM	ACTION	REMARKS
INSTALLATION (cont)				
13 (cont)		j. Ten new tie straps (12)	Install	Install two around protective hose (13); one on hose (20) at radiator; five around hoses (3 and 20) before filter element; one around hoses (3 and 5) after filter element; and one around adapter (26) at transmission
14	Cab guard, filter mounting plate	a. Elbow (9) b. Elbow (11) c. Adapter (10) d. Filter head (8) e. Three capscrews (7) and lock-nuts (6) f. Hose (5) g. Fitting (4) h. Hose (3) i. Fitting (2) j. New filter element (1)	Install Install Install Position Install and tighten Route Connect and tighten Route Connect and tighten Lubricate and install	In filter head (8) In filter head (8) In elbow (11) On filter mounting plate To adapter (10) To adapter (10) To elbow (9) To elbow (9) Apply light coat of transmission oil to gasket; hand tighten only
15	Cab	Engine	Start	
16	Cab guard, filter mounting plate	Filter element (1) and all connections	Check	For oil leakage; tighten connections if necessary
17	Engine compartment	Transmission dipstick	Check oil level	Add oil as necessary; para 2-41b
18	Cab	Engine	Turn off	
19	Rear of vehicle	Rear platform	Install	Para 2-65c

2-41. TRANSMISSION MAINTENANCE (CONT)

f. Vent Assembly.

This task covers: a. Removal c. Inspection
 b. Cleaning d. Installation

INITIAL SETUP

Tools

Safety glasses
 Vise grip pliers
 Needle nose pliers

Materials/Parts

Cleaning solvent Item 1, Appendix C
 Clean cloths Item 2, Appendix C
 Transmission fluid Item 8, Appendix C

Personnel Required

Wheel Vehicle Mechanic MOS 63B

Equipment Condition

Paragraph Condition Description

Vehicle parked on level surface, engine off, parking brake applied, and cab tilted 45 degrees.

KEY

- 1. Vent assembly
- 2. Transmission

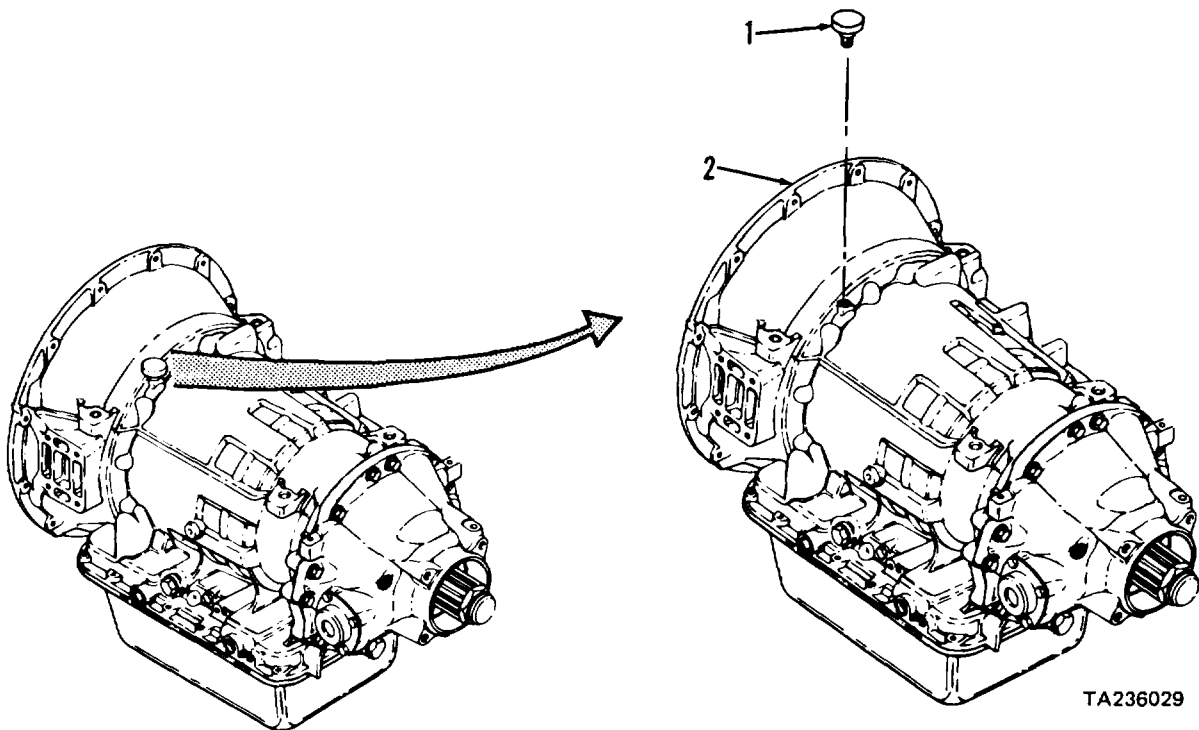

TA236029

2-41. TRANSMISSION MAINTENANCE (CONT)

f. Vent Assembly (cont).

STEP	LOCATION	ITEM	ACTION	REMARKS
REMOVAL				
1	Top front of transmission (2)	a. Vent assembly (1) cap	Remove and discard	Pry from vent assembly stem
		b. Vent assembly (1) stem	Remove and discard	Be sure area around stem is clean; remove using vise grip pliers

WARNING

Dry cleaning solvent (P-D-680), used to clean parts is toxic and flammable. Wear protective goggles and gloves and use only in a well ventilated area. Avoid contact with skin, eyes, and clothes and don't breathe vapors. Do not use near open flame or excessive heat and don't smoke when using it. Failure to do so could cause serious injury. If you become dizzy while using cleaning solvent, get fresh air and medical attention immediately. If contact with skin or clothes is made, flush with large amounts of water. If contact with eyes is made, wash eyes with water and seek medical aid immediately.

CLEANING

2		Vent assembly (1)	Clean	Use cleaning solvent P-D-680. Move up and down in solvent to remove all dirt. Dry with soft, clean, lintless cloth
---	--	-------------------	-------	--

INSPECTION

3		Vent assembly (1)	Inspect	Inspect for damaged threads and blocked passages. Replace if defective
---	--	-------------------	---------	--

INSTALLATION

4	Top front of transmission (2)	New vent assembly (1)	Install	Coat threads with clean transmission fluid. Tighten vent assembly (1) stem using needle nose pliers
---	-------------------------------	-----------------------	---------	---

2-41. TRANSMISSION MAINTENANCE (CONT)

g. Gear Shift Control.

(1) Gear Shift Control Lever and Cable.

This task covers: a. Removal c. Cleaning e. Reassembly
 b. Disassembly d. Inspection f. Installation
 g. Adjustment

INITIAL SETUP

Tools

No. 1 Common Organizational Maintenance

Tool Kit

- Screwdriver
- Screwdriver set
- Torque wrench
- Key set, socket head capscrew
- Socket wrench set
- Puller kit
- Safety Glasses
- Tool Kit, Electrical Connector

Tool Kit, Electrical Connector

- Crimping tool
- Wire stripper

Automotive Mechanic's Tool Kit

Pliers

Soft mallet

Materials/Parts

- | | | |
|------------------|---------------------|-------|
| Cleaning solvent | Item 1, Appendix C | 2-65c |
| Clean cloths | Item , Appendix C | 2-65d |
| Grease | Item 2, Appendix C | 2-32e |
| | Item 26, Appendix C | |

- | | |
|----------------------|--------------------------|
| Cotter pin | FSCM 41625 PN 51001-041 |
| Six tie straps | FSCM 96906 PN MS3667-2-9 |
| Electrical connector | FSCM 77060 PN 2965867 |

Personnel Required

Two Wheel Vehicle Mechanics MOS 63B

Equipment Condition

Paragraph	Condition Description
	Vehicle parked on level surface, engine off, and parking brake applied.
	Cab tilted 45 degrees.
	Gear shift control in neutral (N) position.
	Rear platform removed.
	Heat shield removed.
	Neutral start and backup light switches removed.

KEY

- | | | |
|----------------------|--------------------------|-------------------------------|
| 1. Cotter pin | 19. Tie strap | 37. Screws (4) |
| 2. Trunnion | 20. Tie strap | 38. Socket head capscrews (2) |
| 3. Adapter | 21. Nuts (2) | 39. Locknuts (2) |
| 4. Nut | 22. Screws (2) | 40. Clips (2) |
| 5. Nut | 23. Clamp | 41. Shift lever |
| 6. Selector lever | 24. Spacer | 42. Bushings (2) |
| 7. Nuts (2) | 25. Setscrew | 43. Screws (2) |
| 8. Lock washers (2) | 26. Pivot | 44. Nut plate |
| 9. U-bolt | 27. Cable | 45. Hanger plate |
| 10. Shim | 28. Knob | 46. Rear housing |
| 11. Capscrews (2) | 29. Screws (4) | 47. Lamps (2) |
| 12. Lock washers (2) | 30. Cover | 48. Socket assemblies (2) |
| 13. Bracket | 31. Label | 49. Electrical leads (BLU) |
| 14. Tie straps (2) | 32. Clip nuts (2) | 50. Plain housing |
| 15. Tie straps (3) | 33. Connector housing | 51. Screws (2) |
| 16. Protective hose | 34. Electrical connector | 52. Quadrant plate |
| 17. Nut | 35. Nuts (4) | 53. Spring |
| 18. Clamp | 36. Lock washers (4) | 54. Indicator band |

2-41. TRANSMISSION MAINTENANCE (CONT)

g. Gear Shift Control.

(1) Gear Shift Control Lever and Cable.

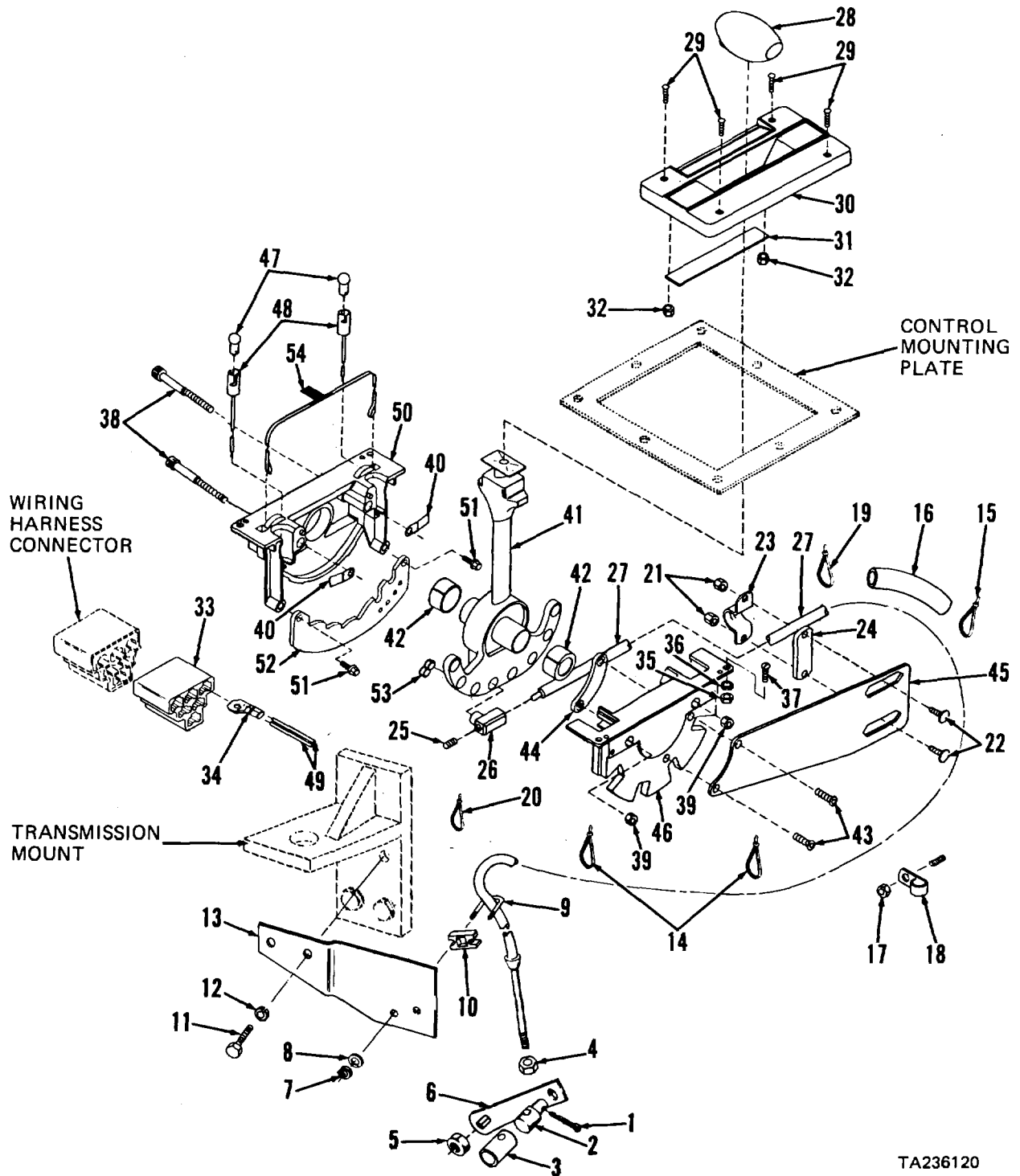

TA236120

2-41. TRANSMISSION MAINTENANCE (CONT)

g. Gear Shift Control.

(1) Gear Shift Control Lever and Cable.

STEP	LOCATION	ITEM	ACTION	REMARKS
REMOVAL				
1	Transmission, left hand side	a. Cotter pin (1)	Remove and discard	
		b. Trunnion (2)	Disconnect	Pull from selector lever (6)
		c. Nut (4)	Loosen	
		d. Trunnion (2), adapter (3), and nut (4)	Remove	From cable (27)
		e. Selector lever (6)	Rotate	Clockwise to last detent position, then counter-clockwise to third detent position
		f. Nut (5)	Loosen	Approximately 1/8 inch
		g. Selector lever (6)	Tap	Tap lightly with plastic hammer to loosen

CAUTION

In steps lh and li below, do not use mechanical stop inside transmission for removal of nut (5). The mechanical stop is used for making calibrated adjustment and could be damaged or altered if used improperly.

		h. Selector lever (6)	Hold tightly	
		i. Nut (5)	Remove	
		j. Selector lever (6)	Remove	
2	Left hand transmission mount	a. Two nuts (7), lock washers (8), U-bolt (9), shim (10), and cable (27)	Remove	From bracket (13)
		b. Two capscrews (11), lock washers (12), and bracket (13)	Remove	
3	Left hand frame rail	Two tie straps (14)	Cut, remove, and discard	Note locations for installation

2-41. TRANSMISSION MAINTENANCE (CONT)

g. Gear Shift Control.

(1) Gear Shift Control Lever and Cable.

STEP	LOCATION	ITEM	ACTION	REMARKS
REMOVAL (cont)				
4	Cab, underside	a. Three tie straps (15)	Cut, remove, and discard	From protective hose (16); note locations for installation
		b. Protective hose (16)	Remove	From gear shift and fifth wheel cables
		c. Nut (17) and clamp (18)	Remove	
		d. Tie straps (19 and 20)	Cut, remove, and discard	Note locations for installation
		e. Two nuts (21), screws (22), clamp (23), and spacer (24)	Remove	
		f. Two screws (43)	Loosen	
		g. Shift lever (41) and cable (27)	Move	Use movement to disengage pivot (26) and move through slot in side of rear housing (46)
		h. Setscrew (25)	Loosen	Remove only if necessary for replacement of pivot (26) or cable (27)
		i. Pivot (26)	Remove	From cable (27)
		j. Cable (27)	Remove	From tractor
5	Cab interior	a. Knob (28)	Remove	Rotate counterclockwise and pull up and off
		b. Four screws (29), cover (30), label (31), and two clip nuts (32)	Remove	
		c. Connector housing (33)	Disconnect	Unplug from wiring harness connector
		d. Electrical connector (34)	a. Disconnect	Pull two electrical leads (49) with connector (34) from connector housing (33)
		b. Remove and discard	Only if inspection indicates need for replacement. Cut two leads as close to connector as possible	

2-41. TRANSMISSION MAINTENANCE (CONT)

g. Gear Shift Control.

(1) Gear Shift Control Lever and Cable.

STEP	LOCATION	ITEM	ACTION	REMARKS
REMOVAL (cont)				
5 (cont)		e. Four nuts (35), lock washers (36), and screws (37)	Remove	
		f. Gear shift control assembly	Remove	Lift out through opening in control mounting plate
DISASSEMBLY				
6	Rear housing (46)	a. Two socket head capscrews (38) and locknuts (39)	Remove	
		b. Housings (46 and 50)	Separate	Keep shift lever (41) mated with plain housing (50)
		c. Two clips (40)	Remove	
		d. Two screws (51) and quadrant plate (52)	Remove	
		e. Spring (53) and indicator band (54)	Remove	
		f. Shift lever (41)	Remove	From plain housing (50)
		g. Two bushings (42)	Remove	Use puller, suitable sleeve, and soft mallet only if replacement is necessary
		h. Two screws (43) and nut plate (44)	Remove	
		i. Hanger plate (45)	Remove	Note position for reassembly; then separate from rear housing (46)
7	Plain housing (50)	a. Two lamps (47)	Remove	
		b. Two socket as- semblies (48) with electri- cal leads (49)	Remove	

2-41. TRANSMISSION MAINTENANCE (CONT)

- g. Gear Shift Control (cont).
- (1) Gear Shift Control Lever and Cable (cont).

STEP	LOCATION	ITEM	ACTION	REMARKS
CLEANING				
8	a.	Cable (27), knob (28), cover (30), lamps (47), socket assemblies (48), and leads (49)	Clean	Wipe with clean, dry cloth

WARNING

Dry cleaning solvent (P-D-680), used to clean parts is toxic and flammable. Wear protective goggles and gloves and use only in a well ventilated area. Avoid contact with skin, eyes, and clothes and don't breathe vapors. Do not use near open flame or excessive heat and don't smoke when using it. Failure to do so could cause serious injury. If you become dizzy while using cleaning solvent, get fresh air and medical attention immediately. If contact with skin or clothes is made, flush with large amounts of water. If contact with eyes is made, wash eyes with water and seek medical aid immediately.

Compressed air must not exceed 30 psi. Wear safety glasses when drying parts with compressed air. Failure to do so could cause serious injury to eyes and possible blindness. If you hurt your eyes or if a foreign object is blown into your eyes, seek medical attention immediately.

b.	All other parts	Clean	Use cleaning solvent P-D-680; dry using compressed air
----	-----------------	-------	--

INSPECTION

9	a.	Cable (27)	Inspect	Replace if cracked, broken, kinked, or otherwise damaged
	b.	Label (31) and indicator band (54)	Inspect	Replace if damaged or illegible

2-41. TRANSMISSION MAINTENANCE (CONT)
--

g. Gear Shift Control (cont).

(1) Gear Shift Control Lever and Cable (cont).

STEP	LOCATION	ITEM	ACTION	REMARKS
INSPECTION (cont)				
9 (cont)		c. Lamps (47)	Inspect	Replace if filaments or glass broken
		d. Electrical leads (49)	Inspect	Replace with socket assembly (48) if insulation frayed, cut, or cracked or if conductor corroded or broken
		e. Shift lever (41)	Inspect	Replace if cracked, broken, distorted, or holes for pivot (26) out-of-round
		f. Rear housing (46) and quadrant plate (52)	Inspect	Replace if cracked, broken, distorted, or detents worn
		g. All other parts	Inspect	Replace if cracked, broken, worn, or threads damaged
REASSEMBLY				
10	Rear housing (46)	a. Hanger plate (45)	Position	On rear housing (46) at location noted during disassembly
		b. Nut plate (44) and two screws (43)	Install	Do not tighten screws
		c. Two bushings (42)	Install	Press on housings (46 and 50)
		d. Shift lever (41)	Position	In plain housing (50)
		e. Two socket assemblies (48) and lamps (47)	Install	
		f. Indicator band (54)	Position	
		g. Spring (53)	Install	
		h. Quadrant plate (52)	Position	
		i. Two screws (51)	Install and tighten	
		j. Two clips (40)	Position	On plain housing (50)
		k. Housings (46 and 50)	Mate	

2-41. TRANSMISSION MAINTENANCE (CONT)

g. Gear Shift Control (cont).

(1) Gear Shift Control Lever and Cable (cont).

STEP	LOCATION	ITEM	ACTION	REMARKS
REASSEMBLY (cont)				
10 (cont)		1. Two socket head capscrews (38) and locknuts (39)	Install	
		m. Label (31)	Position	In cover (30)
		n. Two clip nuts (32)	Install	
INSTALLATION				
11	Cab interior	a. Gear shift control assembly	Install	Through opening in control mounting plate
		b. New electrical connector (34)	a. Install, if necessary	Strip 1/2-inch insulation from two leads (49), twist leads together, and crimp to connector (34) securely
		b. Connect		Push connector with two leads into connector housing (33)
		c. Four nuts (35), lock washers (36), and screws (37)	Install and tighten	
		d. Cover (30)	Position	
		e. Four screws (29)	Install	Tighten to 10 pounds inch torque
		f. Knob (28)	Install	
12	Cab, underside	a. Cable (27)	Position	
		b. Pivot (26)	Install	On cable (27), if removed
		c. Setscrew (25)	Install, if removed	Tighten to 33 pounds inch torque
		d. Cable (27)	Lubricate	Lubricate both ends with grease
		e. Shift lever (41) and cable (27)	Move	Use movement to engage pivot (26) through slot in side of housing (46) and into correct lever hole
		f. Two screws (43)	Tighten	To 90 pounds inch torque
		g. Two screws (22)	Install	Through hanger plate (45) so that screw (22) centers are at line "4" on hanger plate
		h. Spacer (24)	Position	On screws (22)

2-41. TRANSMISSION MAINTENANCE (CONT)

g. Gear Shift Control (cont).

(1) Gear Shift Control Lever and Cable (cont).

STEP	LOCATION	ITEM	ACTION	REMARKS		
INSTALLATION (cont)						
12 (cont)		i. Clamp (23)	Install	Around cable (27) and on screws (22)		
		j. Two nuts (21)	Install and tighten			
		k. Tie strap (19)	Install	On cable (27) at location noted during removal		
		l. Protective hose (16) and three new tie straps (15)	Install removal	At location noted during		
		m. Clamp (13) and nut (17)	Install	Tighten nut (17)		
		n. Connector housing (33)	Connect connector	Push into wiring harness		
		o. Neutral start and backup light switches	Install	Para 2-32e		
		p. New tie strap (20)	Install	On leads (49) at location noted during removal		
		13	Left hand frame rail	a. Cable (27)	Route	
				b. Two new tie straps (14)	Install	At locations noted during removal
c. Heat shield	Install			Para 2-65d		
14	Transmission, left hand side	a. Selector lever (6) shaft	Hold firmly	With pliers; be sure plier jaws contact flat area of shaft and not threaded area; and be sure shaft is in third detent position (refer to step 1 above)		
		b. Selector lever (6)	Install	On selector lever shaft		
CAUTION						
Be careful not to cross thread nut (5) in following step.						
		c. Nut (5)	Start	On selector lever (6) shaft		

2-41. TRANSMISSION MAINTENANCE (CONT)

g. Gear Shift Control (cont).

(1) Gear Shift Control Lever and Cable (cont).

STEP	LOCATION	ITEM	ACTION	REMARKS
INSTALLATION (cont)				
14 (cont)		d. Selector lever (6)	Grasp	Grasp lever at end and pull away from transmission; keep tension on lever until nut (5) is fully installed
		e. Nut (5)	Tighten	To 17 pounds foot torque
15	Left hand transmission mount	a. Bracket (13)	Position	
		b. Two capscrews (11) and lock washers (12)	Install and tighten	
		c. Shim (10) and cable (27)	Position	At bracket (13)
		d. U-bolt (9)	Position	Around cable (27), through shim (10) and bracket (13)
		e. Two lock washers (8) and nuts (7)	Install	Do not tighten nuts
16	Cab tilt pump	Cab Lower		To normal operating position
17	Transmission, left hand side	a. Trunnion (2) and adapter (3)	Assemble	
		b. Nut (4)	Install	On cable (27) shaft
		c. Trunnion (2) and adapter (3)	Install	On cable (27) shaft; center trunnion on threaded end of cable
		d. Trunnion (2)	Position	In selector lever (6) hole
		e. New cotter pin (1)	Install	In trunnion (2); do not spread
		f. Selector lever (6)	Rotate	To neutral (N) position
		g. Shift lever (41)	Position	In neutral (N) position
		h. Two nuts (7)	Tighten	Centers adjustment range
ADJUSTMENT				
18	Cab interior	Shift lever (41)	a. Check operation	Shift lever should move easily and give a crisp detent feel in each position

2-41. TRANSMISSION MAINTENANCE (CONT)

- g. Gear Shift Control (cont).
- (1) Gear Shift Control Lever and Cable (cont).

STEP	LOCATION	ITEM	ACTION	REMARKS
------	----------	------	--------	---------

ADJUSTMENT (cont)

NOTE

When linkage is correctly adjusted, trunnion (2) and pivot (26) can be moved freely in each range. If adjustment is necessary, proceed as follows.

19	Transmission, left hand side	b. Position		Place shift lever in neutral (N) position
		a. Cotter pin (1)	Remove	
		b. Trunnion (2)	Disengage	From selector lever (6)
		c. Selector lever (6)	Position	Place in neutral (N) position
		d. Nut (4)	Loosen	
		e. Trunnion (2)	Adjust	Turn on end of cable (27) until trunnion freely aligns with hole in selector lever
		f. Cotter pin (1)	Install	Do not spread

NOTE

Repeat step 19 above, checking freedom of movement of trunnion (2) for all gear shift ranges. When trunnion (2) enters hole in selector lever (6) freely in each position, proceed as follows.

20	Cab interior	g. Nut (4)	Tighten	
		h. Cotter pin (1)	Spread	
		Tractor Road test		Road test tractor to be sure that shift lever functions properly, that indicator band indicates proper gear range, and that gear range selected is correct
21	Tractor frame	Rear platform	Install	Para 2-65c

2-41. TRANSMISSION MAINTENANCE (CONT)

- g. Gear Shift Control (cont).
- (2) Control Mounting Plate.

This task covers:

- a. Removal
- b. Cleaning
- c. Inspection
- d. Installation

INITIAL SETUP:

<u>Tools</u>		<u>Equipment Condition</u>	<u>Condition Description</u>
No. 1 Common Organizational Maintenance Tool Kit		Paragraph	
Screwdriver			Vehicle parked on level surface, engine off, and parking brake applied. Cab tilted 45 degrees.
Socket wrench set			
Safety glasses			
<u>Materials/Parts</u>		2-41g(1)	Gear shift control lever removed.
Cleaning solvent	Item 1, Appendix C	2-78a	Fifth wheel control lever removed.
Clean cloths	Item 2, Appendix C	2-26c(2)	Low air pressure buzzer removed.
<u>Personnel Required</u>			
Two Wheel Vehicle Mechanics MOS 63B			

KEY

- 1. Locknut
- 2. Electrical lead (WHT)
- 3. Locknuts (8)
- 4. Screws (8)
- 5. Plate

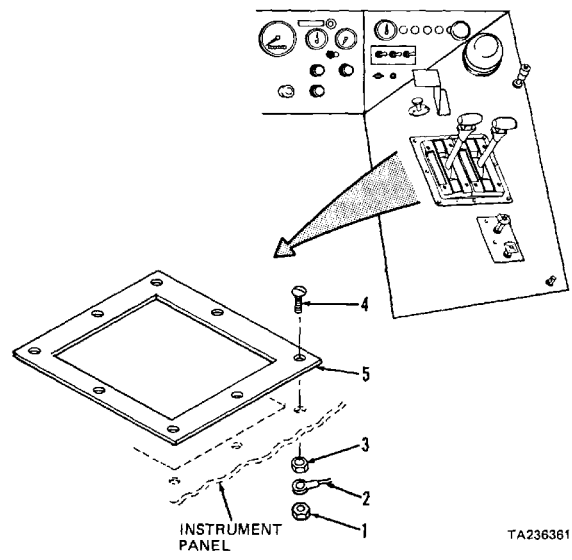

TA236361

2-41. TRANSMISSION MAINTENANCE (CONT)

g. Gear Shift Control (cont).

(2) Control Mounting Plate (cont).

STEP	LOCATION	ITEM	ACTION	REMARKS
REMOVAL				
1	Right hand instrument panel	a. Locknut (1)	Remove	
		b. Electrical lead (2)	Disconnect	From screw (4)
		c. Eight locknuts (3)	Remove	While assistant prevents screws (4) from turning
		d. Eight screws (4)	Remove	
		e. Plate (5)	Remove	Lift from instrument panel

CLEANING

2

WARNING

Dry cleaning solvent (P-D-680), used to clean parts is toxic and flammable. Wear protective goggles and gloves and use only in a well ventilated area. Avoid contact with skin, eyes, and clothes and don't breathe vapors. Do not use near open flame or excessive heat and don't smoke when using it. Failure to do so could cause serious injury. If you become dizzy while using cleaning solvent, get fresh air and medical attention immediately. If contact with skin or clothes is made, flush with large amounts of water. If contact with eyes is made, wash eyes with water and seek medical aid immediately.

		All parts	Clean	Use cleaning solvent P-D-680; dry using clean cloths
INSPECTION				
3		All parts	Inspect	Replace if cracked, broken, or threads damaged

INSTALLATION

4	Right hand instrument panel	a. Plate (5)	Position	Align mounting holes
		b. Eight screws (4)	Install	

2-41. TRANSMISSION MAINTENANCE (CONT)

g. Gear Shift Control (cont).

(2) Control Mounting Plate (cont).

STEP	LOCATION	ITEM	ACTION	REMARKS	
INSTALLATION (cont)					
4 (cont)		c. Eight locknuts (3)	Install and tighten	While assistant prevents screws (4) from turning	
		d. Electrical lead (2)	Position	On screw (4)	
		e. Locknut (1)	Install and tighten		
		f. Low air pres- sure buzzer	Install	Para 2-26c(2)	
		g. Fifth wheel control lever	Install	Para 2-78a	
		h. Gear shift control lever	Install	Para 2-41g(1)	
	5	Cab tilt pump	Cab Lower	To normal operating position	

2-41. TRANSMISSION MAINTENANCE (CONT)

h. Shift Lockout Cylinder, Lines, and Fittings.

(1) Shift Lockout Lines and Fittings.

This task covers:

- a. Removal
- b. Cleaning
- c. Inspection
- d. Repair
- e. Installation
- f. Testing

INITIAL SETUP:

Tools

- No. 1 Common Organizational Maintenance Tool Kit
 - Adjustable open end wrench
 - Fine tooth hacksaw
 - Machinist's vise
 - Scratch wire brush
 - Safety glasses
 - Machinist's steel rule
 - Mandrel assembly tool
 - FSCM 00624 PN 1582-8

- Hydraulic oil Item 22, Appendix C
- Teflon tape Item 43, Appendix C
- Two tie straps FSCM 96906 PN MS3667-1-9
- Ten tie straps FSCM 96906 PN MS3667-2-9.

Personnel Required

Wheel Vehicle Mechanic MOS 63B

Equipment Condition

Paragraph	Condition Description
-----------	-----------------------

Materials/Parts

- Cleaning solvent Item 1, Appendix C
- Clean cloths Item 2, Appendix C
- Tags Item 14, Appendix C

- 2-65d Vehicle parked on level surface, engine off, and parking brake applied. Cab tilted 45 degrees. Heat shield removed.

KEY

- | | |
|---|---|
| <ul style="list-style-type: none"> 1. Connector 2. Tubing (BLU) 3. Tee 4. Tie straps (6) 5. Elbow 6. Tubing (BLU) 7. Tie straps (2) 8. Connector 9. Tubing (BLU) 10. Connector 11. Hose (BLK) 12. Nut | <ul style="list-style-type: none"> 13. Lock washer 14. Capscrew 15. Elbow 16. Swivel connector 17. Tie straps (4) 18. Elbow 19. Bulkhead connector 20. Locknuts (3) 21. Clamps (3) 22. Locknut 23. Clamp |
|---|---|

2-41. TRANSMISSION MAINTENANCE (CONT)

h. Shift Lockout Cylinder, Lines, and Fittings (cont).

(1) Shift Lockout Lines and Fittings (cont).

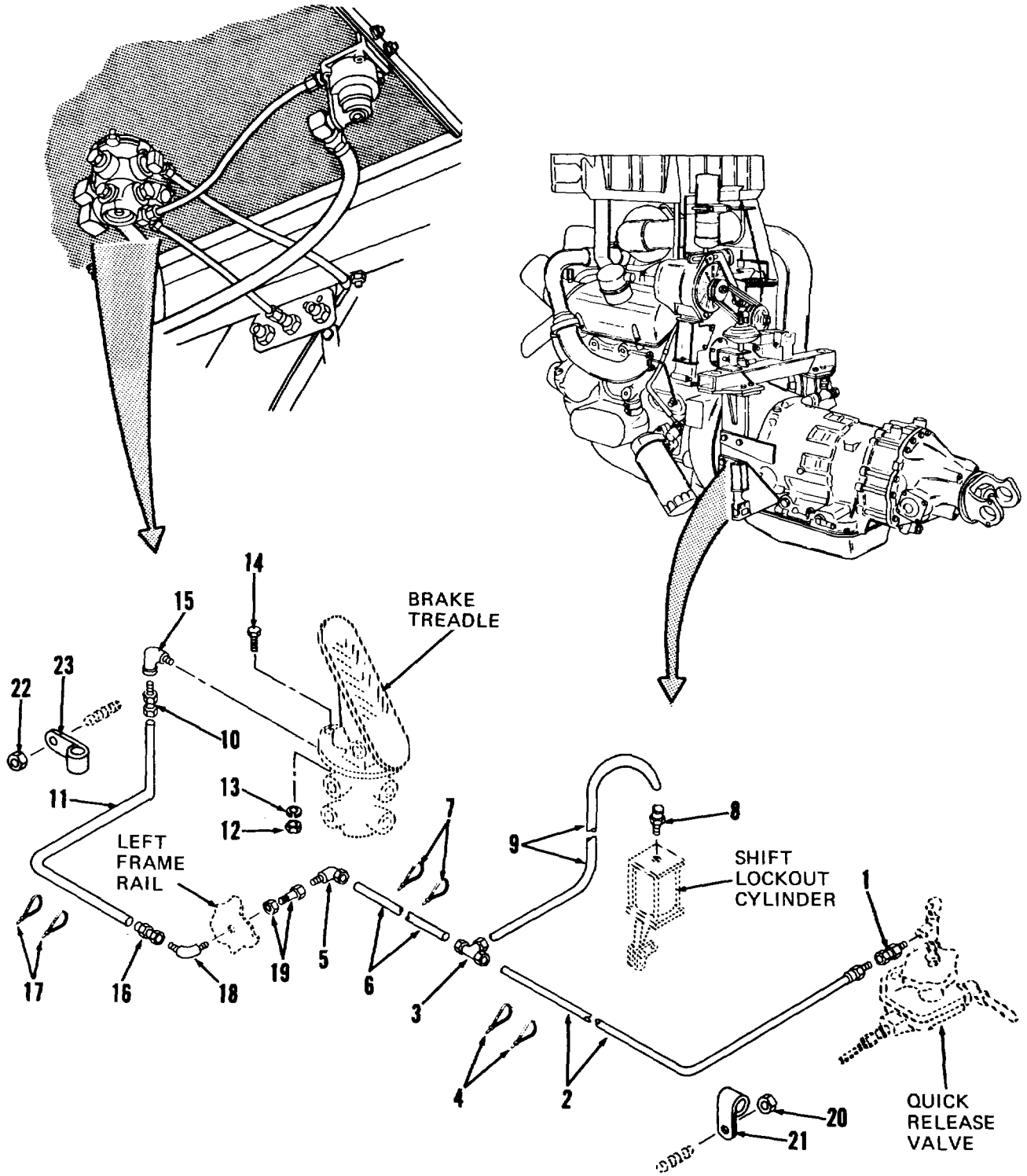

TA236142

2-41. TRANSMISSION MAINTENANCE (CONT)

h. Shift Lockout Cylinder, Lines, and Fittings (cont).

(1) Shift Lockout Lines and Fittings (cont).

STEP	LOCATION	ITEM	ACTION	REMARKS
------	----------	------	--------	---------

REMOVAL

WARNING

Relieve all pressure from tractor air system before proceeding. Failure to do so could result in serious injury. If you are injured, seek medical aid immediately.

1	Tractor, left side, rear air tank, bottom	Drain cock	Open	To relieve all air pressure
---	---	------------	------	-----------------------------

NOTE

Tag ends of tubing and hose before removal to aid installation.

2	Tractor frame, right rear	a. Connector (1) nut	Loosen	
		b. Tubing (2) with nut	Tag and disconnect	From connector (1)
		c. Connector (1)	Remove	From tee at quick release valve
3	Left frame rail, inside	a. Three tee (3) nuts	Loosen	
		b. Tubing (2, 6, and 9) with nuts	Tag and disconnect	From tee (3)
		c. Tee (3)	Remove	
		d. Six tie straps (4)	Cut, remove, and discard	Only if necessary to remove tubing (2). Note locations for installation
		e. Three locknuts (20) and clamps (21)	Remove	Only if necessary to remove tubing (2)
		f. Tubing (2)	Remove	From tractor
		g. Elbow (5) nut	Loosen	
		h. Tubing (6) with nut	Tag and disconnect	From elbow (5)
		i. Elbow (5)	Remove	Note position of elbow for installation

2-41. TRANSMISSION MAINTENANCE (CONT)

h. Shift Lockout Cylinder, Lines, and Fittings (cont).

(1) Shift Lockout Lines and Fittings (cont).

STEP	LOCATION	ITEM	ACTION	REMARKS
REMOVAL (cont)				
3 (cont)		j. Two tie straps (7)	Cut, remove, and discard	Only if necessary to remove tubing (6). Note locations for installation
		k. Tubing (6)	Remove	From tractor
4	Transmission, left side	a. Connector (8) nut	Loosen	
		b. Tubing (9) with nut	Tag and disconnect	From connector (8)
		c. Connector (8)	Remove	From shift lockout cylinder
		d. Tubing (9)	Remove	From tractor
5	Left frame rail, outside	a. Swivel connector (16)	Disconnect	From elbow (18)
		b. Four tie straps (17)	Cut, remove, and discard	Note locations for installation
		c. Elbow (18)	Remove	Note position of elbow for installation
		d. Bulkhead fitting (19)	Remove	Remove fitting nut; then pull fitting from inside frame rail
6	Brake	a. Locknut (22) and clamp (23)	Remove	
		b. Connector (10)	Remove	From elbow (15)
		c. Hose (11) with connectors (10 and 16)	Remove	From tractor

NOTE

Perform steps 6d and 6e below only if necessary to remove elbow (15) from brake treadle.

d.	Nut (12), lock washer (13), and capscrew (14)	Remove	From brake treadle front mounting hole (allows removal of elbow)
e.	Elbow (15)	Remove	From top front brake treadle port; note position for installation

2-41. TRANSMISSION MAINTENANCE (CONT)

h. Shift Lockout Cylinder, Lines, and Fittings (cont).

(1) Shift Lockout Lines and Fittings (cont).

STEP	LOCATION	ITEM	ACTION	REMARKS
------	----------	------	--------	---------

CLEANING

7		a. Tubing (2, 6, and 9) and hose (11)	Clean	Wipe with a clean cloth moistened with water
---	--	---------------------------------------	-------	--

WARNING

Dry cleaning solvent (P-D-680), used to clean parts is toxic and flammable. Wear protective goggles and gloves and use only in a well ventilated area. Avoid contact with skin, eyes, and clothes and don't breathe vapors. Do not use near open flame or excessive heat and don't smoke when using it. Failure to do so could cause serious injury. If you become dizzy while using cleaning solvent, get fresh air and medical attention immediately. If contact with skin or clothes is made, flush with large amounts of water. If contact with eyes is made, wash eyes with water and seek medical aid immediately.

Compressed air must not exceed 30 psi. Wear safety glasses when drying parts with compressed air. Failure to do so could cause serious injury to eyes and possible blindness. If you hurt your eyes or if a foreign object is blown into your eyes, seek medical attention immediately.

		b. All other parts	Clean	Use cleaning solvent P-D-680; dry with compressed air
--	--	--------------------	-------	---

INSPECTION

8		a. Tubing (2, 6, and 9) and hose (11)	Inspect	Replace if cracked, split, chafed, or deteriorated. Refer to step 9 below for hose (11) replacement; refer to step 10 below for tubing (2, 6, or 9) replacement
---	--	---------------------------------------	---------	---

2-41. TRANSMISSION MAINTENANCE (CONT)

h. Shift Lockout Cylinder, Lines, and Fittings (cont).

(1) Shift Lockout Lines and Fittings (cont).

STEP	LOCATION	ITEM	ACTION	REMARKS
INSPECTION (cont)				
8 (cont)		b. All other parts	Inspect	Replace if cracked, worn, distorted, or threads damaged. Refer to step 9 below for replacement of hose connectors (10 and 16); refer to step 10 below for replacement of tubing connectors (1, 3, 5, and 8)
REPAIR				
9	Hose (11)	a. Connector (10 or 16) b. Mandrel assembly tool c. Hose (11)	Place connector socket in vise as shown Install in connector nipple; tighten nut of connector. Turn tool counterclockwise to remove connector nipple and nut Turn hose (11) clockwise out of connector (10 or 16) socket; discard hose (11)	

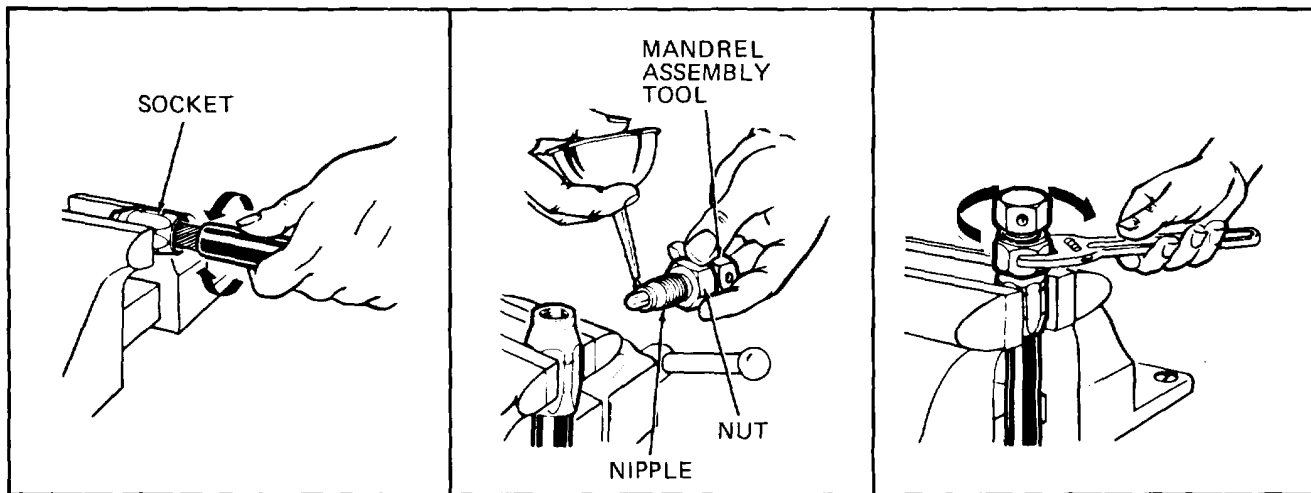

TA236149

NOTE

Repeat steps 9a thru 9c above to remove remaining connector (10 or 16) from hose (11).

2-41. TRANSMISSION MAINTENANCE (CONT)

h. Shift Lockout Cylinder, Lines, and Fittings (cont).

(1) Shift Lockout Lines and Fittings (cont).

STEP	LOCATION	ITEM	ACTION	REMARKS
------	----------	------	--------	---------

REPAIR (cont)

WARNING

9
Wear(cont)
Do not use near
using it. Failure to do so
you become dizzy while using cleaning solvent, get
and medical attention immediately. If contact with skin or clothes is
flush with large amounts of water. If contact with eyes is made, wash eyes
with water and seek medical aid immediately.

Dry cleaning solvent (P-D-680), used to clean parts is toxic and flammable. protective goggles and gloves and use only in a well ventilated area. Avoid contact with skin, eyes, and clothes and don't breathe vapors. open flame or excessive heat and don't smoke when could cause serious injury. If fresh air made,

d.		Connector (10 or 16)	Clean	Use cleaning solvent P-D-680; allow to air dry. Use wire brush to remove all hose residue from socket and nipple of connectors
e.		Hose (11)	Cut to proper length	Use new hose; use old hose to determine proper length required. Cut hose square using fine tooth hacksaw
f.		Connector (10 or 16)	Place connector socket in vise as shown	
g.		Hose (11)	Screw hose counterclockwise into socket until hose bottoms; back hose off 1/4 to 1/2 turn	
h.		Mandrel assembly tool	Oil nipple threads, mandrel assembly tool, and inside of hose liberally using hydraulic oil. Tighten connector nipple and nut on mandrel assembly tool. Apply oil to all parts	
i.		Connector (10 or 16)	Screw nipple clockwise into socket and hose. Allow 1/32 to 1/16 inch clearance between nut and socket so nut will swivel. Remove mandrel assembly tool from connector. Remove connector from vise	

NOTE

Repeat steps 9f thru 9i above to install remaining connector (10 or 16) on hose (11).

2-41. TRANSMISSION MAINTENANCE (CONT)

h. Shift Lockout Cylinder, Lines, and Fittings (cont).

(1) Shift Lockout Lines and Fittings (cont).

STEP	LOCATION	ITEM	ACTION	REMARKS
REPAIR (cont)				
10	Tubing (2, 6, or 9)	a. Tubing (2, 6, or 9)	Cut Between nut and sleeve	
		b. Nut Remove	Slide from tubing	
		c. Insert	Remove, if necessary	Pull from tubing only if separated from fitting (1, 3, 5, or 8)
		d. Sleeve	Discard	

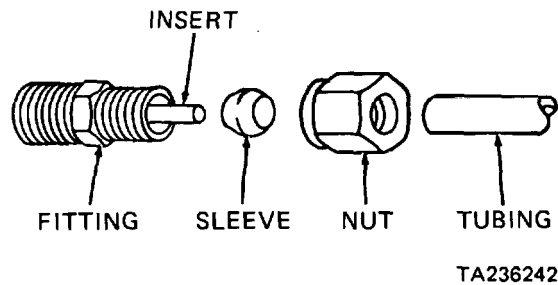

NOTE

Repeat steps 10a thru 10d above to disassemble remaining connectors from tubing (2, 6, or 9).

e. Tubing (2, 6, or 9)	Cut to proper length	Use new tubing; use old tubing to determine proper length
f. Nut Position		Slide onto tubing; threaded end out
g. New sleeve	Position	Slide onto tubing
h. Insert	Install, if necessary	Push into tubing only if separated from fitting

WARNING

Tubing must be installed over insert for secure connection. Installation of connector without insert will allow air pressure to force tubing from fitting, resulting in dangerous loss of air pressure.

2-41. TRANSMISSION MAINTENANCE (CONT)

h. Shift Lockout Cylinder, Lines, and Fittings (cont).

(1) Shift Lockout Lines and Fittings (cont).

STEP	LOCATION	ITEM	ACTION	REMARKS
REPAIR (cont)				
10 (cont)		i. Tubing	Install	Push onto insert until seated inside fitting
		j. Nut Tighten		Hand tight only; prevents loss of sleeve before installation

NOTE

Repeat steps 10e thru 10j above to install remaining connectors on tubing (2, 6, or 9).

INSTALLATION

11	Brake treadle	a. Elbow (15)	a. Tape b. Install	Wrap threads with Teflon tape In brake treadle top front port; tighten to position noted during removal
		b. Capscrew (14), lock washer (13), and nut (12)	Install and tighten	If removed
		c. Connector (10) with hose (11)	a. Connect b. Tighten	To elbow (15)
		d. Hose (11)	Route	To left frame rail
		e. Clamp (23)	Position	
		f. Locknut (22)	Install and tighten	
12	Left frame rail, outside	a. Bulkhead fitting (19)	Install	Push into frame rail from inside, install fitting nut, and tighten
		b. Elbow (18)	a. Tape b. Install	Wrap pipe thread end with Teflon tape In bulkhead fitting (19); tighten to position noted during removal
		c. Swivel connector (16) with hose (11)	a. Connect b. Tighten	To elbow (18)
		d. Four new tie straps (17)	Install	At locations noted during removal

2-41. TRANSMISSION MAINTENANCE (CONT)

h. Shift Lockout Cylinder, Lines, and Fittings (cont).

(1) Shift Lockout Lines and Fittings (cont).

STEP	LOCATION	ITEM	ACTION	REMARKS	
INSTALLATION (cont)					
13	Transmission, left side	a. Connector (8)	a. Tape	Wrap threads with Teflon tape On shift lockout cylinder To connector (8)	
		b. Install			
		b. Connector (8) nut with tubing (9)	a. Connect b. Tighten		
		c. Tubing (9)	Route	To left frame rail	
14	Left frame rail, inside	a. Elbow (5)	a. Tape b. Install	Wrap threads with Teflon tape Tighten to position noted during removal To elbow (5)	
		b. Elbow (5) nut with tubing (6)	a. Connect b. Tighten		
		c. Tubing (6)	Route	At locations noted during removal To tee (3) as tagged	
		d. Two new tie straps (7)	Install		
		e. Three tee (3) nuts with tubing (2, 6, and 9)	a. Connect b. Tighten		
		f. Tubing (2)	Route		
		g. Three clamps (21)	Position		To quick release valve
		h. Three locknuts (20)	Install and tighten		
15	Tractor frame, right rear	a. Connector (1)	a. Tape b. Install	Wrap threads with Teflon tape In tee at quick release valve To connector (1)	
		b. Connector (1) nut with tubing (2)	a. Connect b. Tighten		
16	Tractor, left side, rear air tank, bottom	Drain cock	Close		
17	Frame, left hand side	Heat shield	Install	Para 2-65d	

2-41. TRANSMISSION MAINTENANCE (CONT)

h. Shift Lockout Cylinder, Lines, and Fittings (cont).

(1) Shift Lockout Lines and Fittings (cont).

STEP	LOCATION	ITEM	ACTION	REMARKS
INSTALLATION (cont)				
18	Cab tilt pump	Cab	Lower	To normal operating position
TESTING				
19	Cab	a. Key switch b. Accelerator pedal c. AIR PRESS gage d. Key switch	Turn on Press Watch Turn off	Start engine Operate engine at 1200 rpm For 100 psi indication Shut down engine when AIR PRESS gage indicates 100 psi
20	Shift lockout lines and fittings	e. Brake treadle All connections	Press fully Check	Use assistant Use soap solution; inspect for leaks. Tighten or replace parts as necessary
21	Cab	Brake treadle	Release	

2-41. TRANSMISSION MAINTENANCE (CONT)

h. Shift Lockout Cylinder, Lines, and Fittings (cont).

(2) Shift Lockout Cylinder and Linkage.

This task covers:

- a. Removal
- b. Disassembly
- c. Cleaning
- d. Inspection
- e. Reassembly
- f. Installation
- g. Testing

INITIAL SETUP:

Tools

No. 1 Common Organizational Maintenance Tool Kit
 Adjustable open end wrench
 Socket wrench set
 Pliers
 Screwdriver set
 Safety glasses
 Machinist's steel rule

Materials/Parts

Cleaning solvent Item 1, Appendix C
 Clean cloths Item 2, Appendix C

Personnel Required

Two Wheel Vehicle Mechanics MOS 63B

Equipment Condition

Paragraph	Condition Description
2-41h(l)	Vehicle parked on level surface, engine off, and parking brake applied. Tubing and connector removed from shift lockout cylinder.

STEP	LOCATION	ITEM	ACTION	REMARKS
------	----------	------	--------	---------

REMOVAL

1	Transmission, left hand side	a. Air cylinder (3) port	Plug	Prevents entry of foreign matter
		b. Two capscrews (1) and lock washers (2)	Remove	Support air cylinder (3)
		c. Air cylinder (3) with linkage	Remove	As an assembly
		d. Sleeve (4) and washer (5)	Remove	Slide off threaded pin (12)
		e. Two capscrews (6), lock washers (7), and plate (8)	Remove replacement	Only if necessary for

2-41. TRANSMISSION MAINTENANCE (CONT)

h. Shift Lockout Cylinder, Lines, and Fittings (cont).

(2) Shift Lockout Cylinder and Linkage (cont).

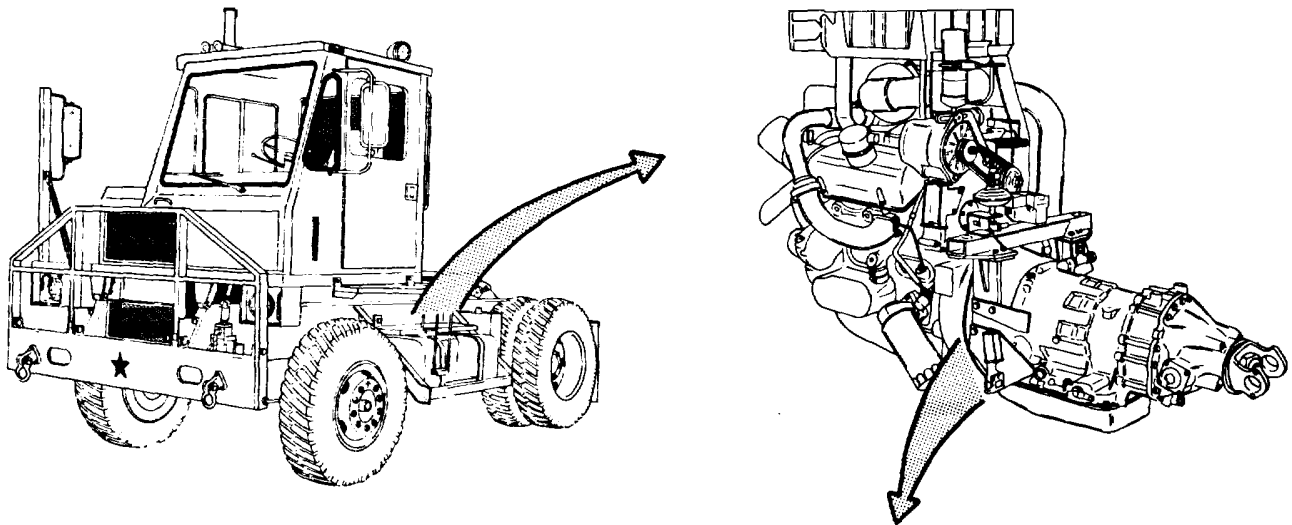

KEY

- 1. Capscrews (2)
- 2. Lock washers (2)
- 3. Air cylinder
- 4. Sleeve
- 5. Washer
- 6. Capscrews (2)
- 7. Lock washers (2)
- 8. Plate
- 9. Nut
- 10. Nut
- 11. Nut
- 12. Threaded pin
- 13. Retaining rings (3)
- 14. Lever
- 15. Bushings (3)
- 16. Cylinder rod block
- 17. Nut
- 18. Retaining rings (3)
- 19. Rod block
- 20. Lever
- 21. Bushings (3)

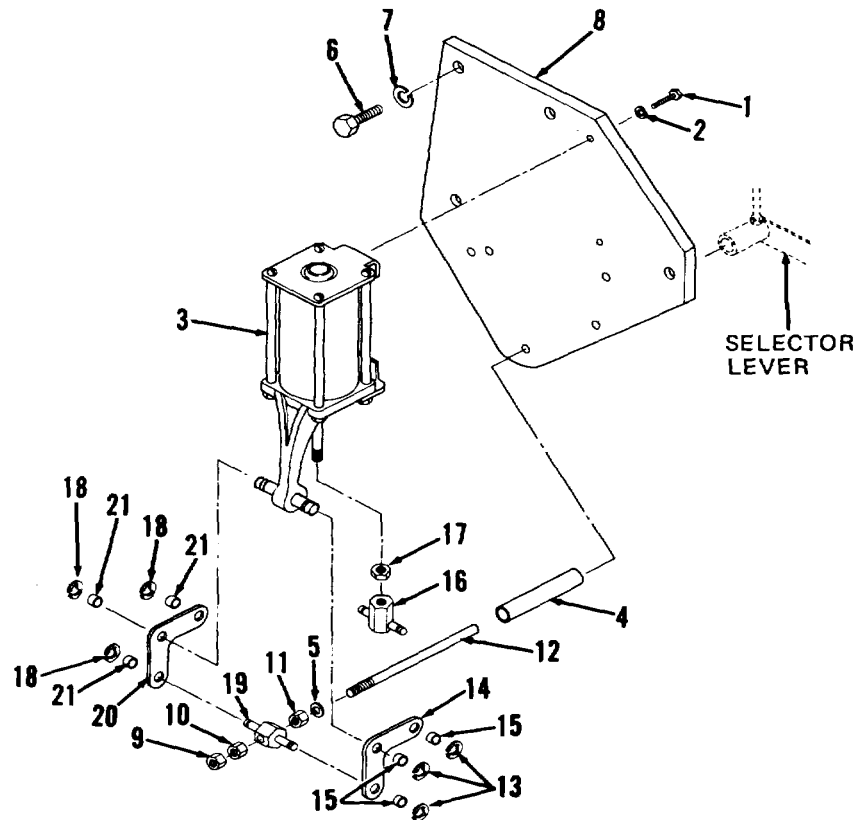

TA236143

2-41. TRANSMISSION MAINTENANCE (CONT)

h. Shift Lockout Cylinder, Lines, and Fittings (cont).

(2) Shift Lockout Cylinder and Linkage (cont).

STEP	LOCATION	ITEM	ACTION	REMARKS
DISASSEMBLY				
2	Air cylinder (3)	a. Two nuts (9 and 10)	Remove	
		b. Nut (11)	Loosen	
		c. Nut (11) and threaded pin (12)	a. Remove b. Separate	
		d. Three retaining rings (13)	Remove	
		e. Lever (14)	Remove	
		f. Three bushings (15)	Remove	From lever (14) only if necessary for replacement
		g. Three retaining rings (18), rod block (19), and lever (20)	Remove	
		h. Three bushings (21)	Remove	From lever (20) only if necessary for replacement
		i. Nut (17)	Loosen	
		j. Cylinder rod block (16) and nut (17)	Remove	

CLEANING

WARNING

Dry cleaning solvent (P-D-680), used to clean parts is toxic and flammable. Wear protective goggles and gloves and use only in a well ventilated area. Avoid contact with skin, eyes, and clothes and don't breathe vapors. Do not use near open flame or excessive heat and don't smoke when using it. Failure to do so could cause serious injury. If you become dizzy while using cleaning solvent, get fresh air and medical attention immediately. If contact with skin or clothes is made, flush with large amounts of water. If contact with eyes is made, wash eyes with water and seek medical aid immediately.

2-41. TRANSMISSION MAINTENANCE (CONT)

h. Shift Lockout Cylinder, Lines, and Fittings (cont).

(2) Shift Lockout Cylinder and Linkage (cont).

STEP	LOCATION	ITEM	ACTION	REMARKS
------	----------	------	--------	---------

CLEANING (cont)

WARNING

Compressed air must not exceed 30 psi. Wear safety glasses when drying parts with compressed air. Failure to do so could cause serious injury to eyes and possible blindness. If you hurt your eyes or if a foreign object is blown into your eyes, seek medical attention immediately.

3		Exterior of air cylinder (3) and all other parts	Clean	Use cleaning solvent P-D-680; dry using compressed air
INSPECTION				
4		a. Air cylinder (3)	Inspect	Replace if cylinder or end caps cracked or dented, rod bent, threads damaged, or air cylinder inoperative
		b. Bushings (15 and 21)	Inspect	Replace if cracked, worn, or holes elongated
		c. All other parts	Inspect	Replace if cracked, corroded, distorted, bent, or threads damaged

REASSEMBLY

5	Air cylinder (3)	a. Nut (17)	Install	To approximately 2/3 of rod thread
		b. Cylinder rod block (16)	Install	To approximately 1/2 of rod thread
		c. Nut (17)	Tighten	
		d. Three bushings (21)	Install, if removed	In lever (20)
		e. Lever (20)	Position	On rod blocks (16 and 19) and air cylinder (3) pin
		f. Three retaining rings (18)	Install	
		g. Three bushings (15)	Install, if removed	In lever (14)
		h. Lever (14)	Position	

2-41. TRANSMISSION MAINTENANCE (CONT)

h. Shift Lockout Cylinder, Lines, and Fittings (cont).

(2) Shift Lockout Cylinder and Linkage (cont).

STEP	LOCATION	ITEM	ACTION	REMARKS
REASSEMBLY (cont)				
5 (cont)		i. Three retaining rings (13)	Install	
		j. Nut (11)	Install	On threaded pin (12)
		k. Threaded pin (12)	Install	On rod block (19)
		l. Two nuts (10 and 9)	Install	Do not tighten
INSTALLATION				
6	Transmission, left hand side	a. Plate (8)	Position	If removed
		b. Two capscrews (6) and lock washers (7)	Install and tighten	
		c. Washer (5) and sleeve (6)	Position	Slide onto threaded pin (12)
		d. Air cylinder (3) with linkage	Position	Against plate (8) with threaded pin (12) through hole in plate (8)
		e. Two capscrews (1) and lock washers (2)	Install and tighten	
		f. Threaded pin (12)	Adjust	Turn nuts (10 and 11) against rod block (19) until end of threaded pin (12) extends 3/4 inch beyond plate (8)
		g. Nuts (9, 10, Tighten and 11)		Secures adjustment
		h. Plug	Remove	From air cylinder (3) port
		i. Connector and tubing	Install	On shift lockout cylinder (para 2-41h(l))
7	Cab	Air pressure	Restore	Para 2-41h(l)
8	Transmission, left hand side	Air cylinder (3) and tubing	Inspect	Use soap solution; inspect for leaks

2-41. TRANSMISSION MAINTENANCE (CONT)

- h. Shift Lockout Cylinder, Lines, and Fittings (cont).
- (2) Shift Lockout Cylinder and Linkage (cont).

STEP	LOCATION	ITEM	ACTION	REMARKS
TESTING				
9	Cab	Brake treadle	Press fully	
10	Transmission, left hand side	Threaded pin (12)	Watch	For extended and retracted positions. Stroke is 3/4 inch. If necessary loosen nuts (9, 10, and 11) and adjust for proper extended and retracted positions. Do not allow threaded pin (12) to retract into plate (8)

CAUTION

Be sure parking brake is applied and tractor is stationary before proceeding. Improper adjustment may allow gear shift to be placed in reverse position, and tractor motion could damage transmission.

11	Cab	Brake treadle	a. Release	With foot off brake treadle, check proper adjustment by attempting to move gear shift lever to reverse position. Lever should be locked out, and transmission should not be in reverse range
			b. Press fully	

2-41. TRANSMISSION MAINTENANCE (CONT)

- i. Modulator Cable.

This task covers:

- a. Removal
- b. Cleaning
- c. Inspection
- d. Installation

INITIAL SETUP:

Tools

- No. 1 Common Organizational Maintenance Tool Kit
 - Combination wrench set
 - Socket wrench set
 - Torque wrench
 - Safety glasses

Materials/Parts

- Cleaning solvent
 - Clean cloths
 - Transmission fluid
 - Tie straps
- Item 1, Appendix C
 Item 2, Appendix C
 Item 8, Appendix C
 FSCM 96906
 PN MS3667-2-9

Personnel Required

Wheel Vehicle Mechanic MOS 63B

Equipment Condition

Paragraph Condition Description

2-13e Vehicle parked on level surface, engine off, and parking brake applied. Cab tilted 45 degrees. Modulator cable assembly disconnected from throttle linkage (for removal).

KEY

- 1. Capscrew
- 2. Clip
- 3. Modulator cable assembly
- 4. O-ring
- 5. Tie straps (AR)

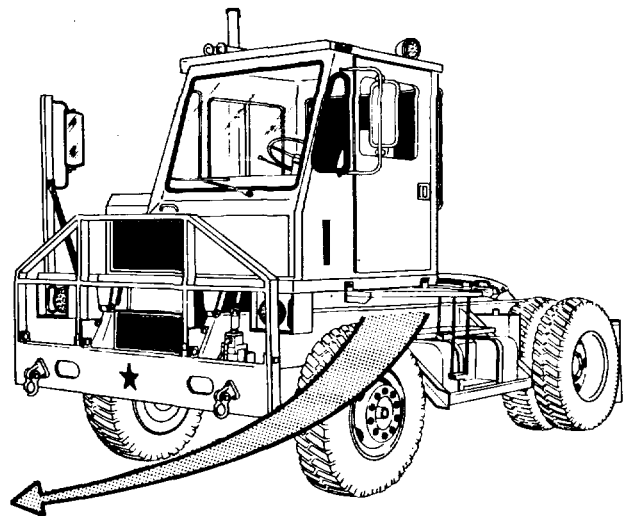
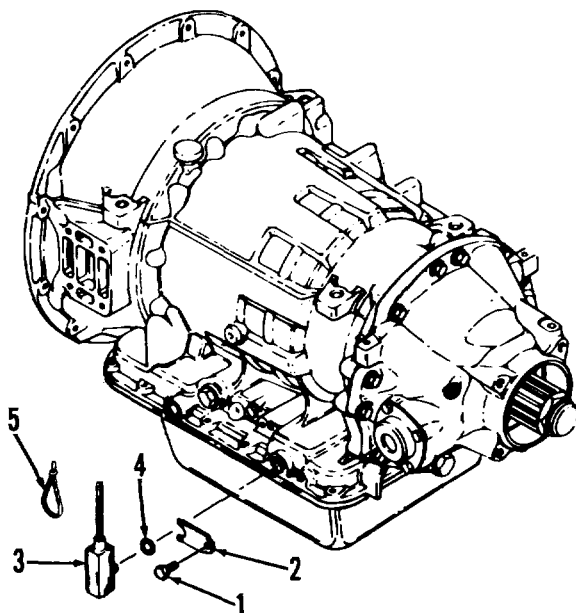

TA236218

2-41. TRANSMISSION MAINTENANCE (CONT)

- i. Modulator Cable (cont).

STEP	LOCATION	ITEM	ACTION	REMARKS
REMOVAL				
1	Transmission, left hand side	a. Capscrew (1) and clip (2)	Remove	
		b. Modulator cable assembly (3)	Remove	From transmission
		c. O-ring (4)	Remove	From modulator cable assembly (3)
		d. Tie straps (5)	Remove	Cut and discard; note locations for installation
		e. Modulator cable assembly (3)	Remove	From tractor
CLEANING				
2		a. Modulator cable assembly (3)	Clean	Use clean, dry cloth
<u>WARNING</u>				
<p>Dry cleaning solvent (P-D-680), used to clean parts is toxic and flammable. Wear protective goggles and gloves and use only in a well ventilated area. Avoid contact with skin, eyes, and clothes and don't breathe vapors. Do not use near open flame or excessive heat and don't smoke when using it. Failure to do so could cause serious injury. If you become dizzy while using cleaning solvent, get fresh air and medical attention immediately. If contact with skin or clothes is made, flush with large amounts of water. If contact with eyes is made, wash eyes with water and seek medical aid immediately.</p> <p>Compressed air must not exceed 30 psi. Wear safety glasses when drying parts with compressed air. Failure to do so could cause serious injury to eyes and possible blindness. If you hurt your eyes or if a foreign object is blown into your eyes, seek medical attention immediately.</p>				
		b. All other parts	Clean	Use cleaning solvent P-D-680; dry using compressed air

2-41. TRANSMISSION MAINTENANCE (CONT)

i. Modulator Cable (cont).

STEP	LOCATION	ITEM	ACTION	REMARKS
INSPECTION				
3		a. Modulator cable assembly (3)	Inspect	Replace if damaged or kinked
		b. All other parts	Inspect	Replace if broken, cracked, or excessively worn
INSTALLATION				
4	Transmission, left hand side	a. O-ring (4)	a. Lubricate b. Install, if re-moved	Use clean transmission fluid On modulator cable assembly; position against shoulder of modulator housing
		b. Modulator cable assembly (3)	Install	On transmission
		c. Clip (2) and capscrew (1)	Install	Tighten capscrew (1) to 15-20 pounds foot torque
		d. Modulator cable assembly (3)	Route	To top rear of engine
		e. New tie straps (5)	Install	At locations noted during removal
5	Engine, top rear	Modulator cable assembly (3)	Connect and adjust	Para 2-13e
6	Cab tilt pump	Cab	Lower	To normal operating position

2-41. TRANSMISSION MAINTENANCE (CONT)

j. Transmission Oil Sampling Valve.

This task covers:

- a. Oil sampling
- b. Removal
- c. Cleaning
- d. Inspection
- e. Installation

INITIAL SETUP:

Tools

No. 1 Common Organizational Maintenance Tool Kit
 Safety glasses
 Socket wrench set
 Adjustable open end wrench

Personnel Required

Wheel Vehicle Mechanic MOS 63B

Equipment Condition

Paragraph Condition Description

Materials/Parts

Cleaning solvent	Item 1, Appendix C	2-34a
Clean cloths	Item 2, Appendix C	
Transmission oil	Item 8, Appendix C	2-65c

Parked on level surface; parking brake applied; engine off.
 Battery ground cable disconnected.
 Rear platform removed.

STEP	LOCATION	ITEM	ACTION	REMARKS
------	----------	------	--------	---------

OIL SAMPLING

1	Transmission, right side	a. Transmission	Warm up	Drive tractor for 15 minutes to warm oil; then shift to neutral, apply parking brakes, and idle engine Under hose (4) Open valve (7) and drain one pint of oil into container; then close valve and remove container
		b. Container	Position	
		c. Hose (4)	Flush	

NOTE

Procure clean sample bottle and a copy of DD Form 2026 (Oil Analysis Request) in accordance with local procedure.

d. Clean sample bottle	a. Open	Remove bottle cap and place on clean surface with edges up
	b. Position	Under hose (4)
	c. Fill	Open valve (7) and fill sample bottle to within 1/2 inch of top

2-41. TRANSMISSION MAINTENANCE (CONT)

j. Transmission Oil Sampling Valve (cont).

KEY

- 1. Hose end
- 2. Hose end
- 3. Hose
- 4. Hose
- 5. Hose end
- 6. Nut
- 7. Sampling valve
- 8. Pipe plug
- 9. Elbow
- 10. Capscrews (2)
- 11. Lock washers (2)
- 12. Battery ground cable
- 13. Bracket

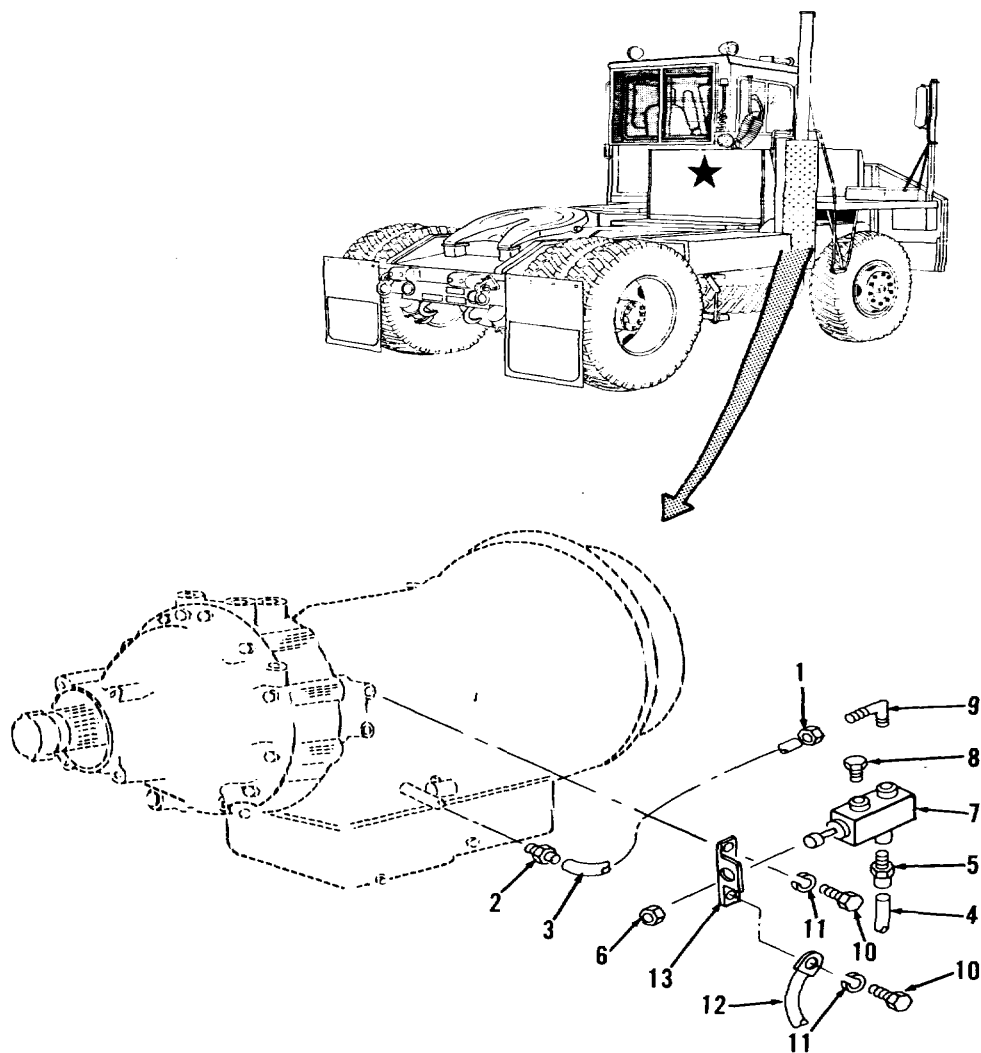

TA236395

2-41. TRANSMISSION MAINTENANCE (CONT)

j. Transmission Oil Sampling Valve (cont).

STEP	LOCATION	ITEM	ACTION	REMARKS
OIL SAMPLING (cont)				
1. (cont)			d. Close	Install and tighten cap; wipe oil from exterior
		e. Engine	e. Package Shut down	Place bottle in plastic bag
2	Office	a. DD Form 2026 b. Oil sample	Fill out a. Package	Place plastic bag with oil sample and completed DD Form 2026 in shipping sack
			b. Ship	On same day sample is taken. Ship according to local procedure

NOTE

Special oil samples will be clearly marked "SPECIAL" and banded with red tape for easy identification at the analysis laboratory.

REMOVAL

3	Transmission, right side	a. Hose end (1) b. Hose end (2) c. Hose (3)	Disconnect Disconnect Remove	From elbow (9) From tee at transmission
4	Sampling valve (7)	a. Hose end (5) b. Nut (6) c. Sampling valve (7) d. Plug (8) e. Elbow (9)	Disconnect Remove Remove Remove Remove	From sampling valve (7) Support sampling valve (7)
5	Transmission, right side	a. Two capscrews (10) and lock washers (11) b. Bracket (13)	Loosen and remove Remove	Place battery ground cable (12) out of the way From transmission

CLEANING

6		a. Hoses (3 and 4)	Clean	Wipe with clean, dry cloth
---	--	--------------------	-------	----------------------------

2-41. TRANSMISSION MAINTENANCE (CONT)

j. Transmission Oil Sampling Valve (cont).

STEP	LOCATION	ITEM	ACTION	REMARKS
CLEANING (cont)				
6 (cont)			<u>WARNING</u>	
		Dry cleaning solvent (P-D-680), used to clean parts is toxic and flammable. Wear protective goggles and gloves and use only in a well ventilated area. Avoid contact with skin, eyes, and clothes and don't breathe vapors. Do not use near open flame or excessive heat and don't smoke when using it. Failure to do so could cause serious injury. If you become dizzy while using cleaning solvent, get fresh air and medical attention immediately. If contact with skin or clothes is made, flush with large amounts of water. If contact with eyes is made, wash eyes with water and seek medical aid immediately.		
		b. All other parts	Clean	Use cleaning solvent P-D-680; dry with clean cloths
INSPECTION				
7		a. Hoses (3 and 4)	Inspect	Replace if cracked, cut, frayed, deteriorated, or otherwise damaged
		b. Sampling valve (7)	Inspect	Replace if cracked, valve inoperative, or evidence of leakage observed
		c. All other parts	Inspect	Replace if cracked, broken, or threads damaged
INSTALLATION				
8	Transmission, right side	a. One capscrew (10) and lock washer (11)	Position	Push through terminal of battery ground cable (12)
		b. Bracket (13)	Position	On transmission
		c. Two capscrews (10) and lock washers (11)	Install and tighten	Secures bracket (13) and battery ground cable (12) to transmission
9	Sampling valve (7)	a. Plug (8)	Install and tighten	
		b. Elbow (9)	Install and tighten	
		c. Hose end (5)	Install and tighten	In sampling valve bottom port

2-41. TRANSMISSION MAINTENANCE (CONT)

j. Transmission Oil Sampling Valve (cont).

STEP	LOCATION	ITEM	ACTION	REMARKS
INSTALLATION (cont)				
10	Transmission, right side	a. Sampling valve (7)	Position	In bracket (13)
		b. Nut (6)	Install and tighten	Secures sampling valve (7) to bracket (13)
		c. Hose end (2)	Connect and tighten	To tee at transmission
		d. Hose (3)	Position	Route free end to elbow (9)
		e. Hose end (1)	Connect and tighten	To elbow (9)
11	Battery box	Battery ground cable	Connect and tighten	Para 2-34a
12	Instrument panel	Key switch	a. Turn on	Start engine and run for several minutes to warm transmission oil
			b. Turn off	Press engine stop button to stop engine
13	Transmission, right side	a. Sampling valve, hoses, and fittings	Check	For oil leaks. Tighten fittings or replace parts as necessary
		b. Transmission oil	Add and check level	Para 2-41b
14	Tractor rear	Rear platform	Install	Para 2-65c

2-41. TRANSMISSION MAINTENANCE (CONT)

k. Dipstick Tube.

This task covers: a. Removal c. Inspection
 b. Cleaning d. Installation

INITIAL SETUP

Tools

No. 1 Common Organizational Maintenance

Tool Kit

- Adjustable open end wrench
- Socket wrench set
- Safety glasses

Materials/Parts

Cleaning solvent Item 1, Appendix C
 Clean cloths Item 2, Appendix C

Personnel Required

Wheel Vehicle Mechanic MOS 63B

Equipment Condition

Paragraph Condition Description

Vehicle parked on level surface, engine off, and parking brake applied. Cab tilted 45 degrees.

2-41b Dipstick removed and transmission fluid drained.

KEY

- 1. Nut
- 2. Capscrew
- 3. Lock washer
- 4. Nut
- 5. Capscrew
- 6. Lock washer
- 7. Bracket
- 8. Dipstick tube

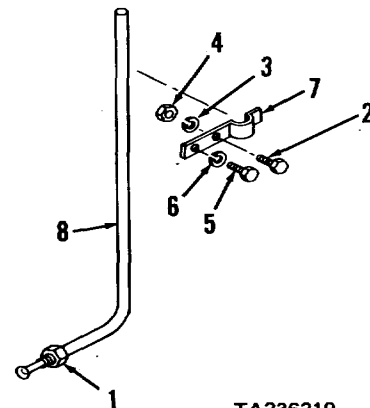
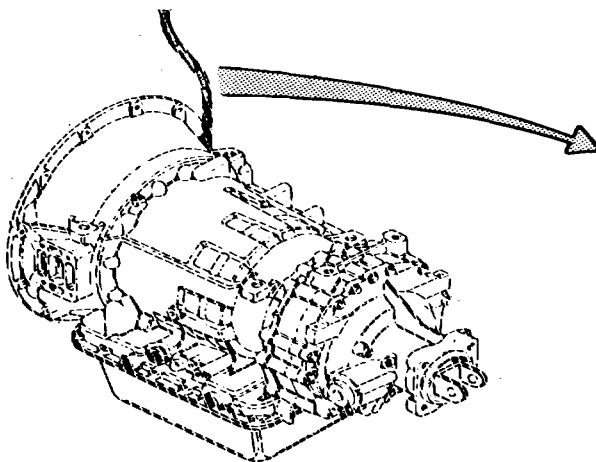

TA236219

2-41. TRANSMISSION MAINTENANCE (CONT)

k. Dipstick Tube (cont).

STEP	LOCATION	ITEM	ACTION	REMARKS
REMOVAL				
1	Transmission oil pan, right hand side	a. Nut (1) b. Dipstick tube (8)	Loosen Disconnect	From transmission oil pan
2	Engine, right hand side, rear	a. Capscrew (2), lock washer (3), and nut (4) b. Capscrew (5), lock washer (6), and bracket (7) c. Dipstick tube (8)	Remove Remove Remove	Support dipstick tube (8) Lower from bottom of tractor

CLEANING

WARNING

Dry cleaning solvent (P-D-680), used to clean parts is toxic and flammable. Wear protective goggles and gloves and use only in a well ventilated area. Avoid contact with skin, eyes, and clothes and don't breathe vapors. Do not use near open flame or excessive heat and don't smoke when using it. Failure to do so could cause serious injury. If you become dizzy while using cleaning solvent, get fresh air and medical attention immediately. If contact with skin or clothes is made, flush with large amounts of water. If contact with eyes is made, wash eyes with water and seek medical aid immediately.

Compressed air must not exceed 30 psi. Wear safety glasses when drying parts with compressed air. Failure to do so could cause serious injury to eyes and possible blindness. If you hurt your eyes or if a foreign object is blown into your eyes, seek medical attention immediately.

3		All parts	Clean	Use cleaning solvent P-D-680; dry using compressed air
---	--	-----------	-------	--

2-41. TRANSMISSION MAINTENANCE (CONT)

k. Dipstick Tube (cont).

STEP	LOCATION	ITEM	ACTION	REMARKS
INSPECTION				
4		a. Dipstick tube (8)	Inspect	Replace if cracked, bent, kinked, or damaged
		b. All other parts	Inspect	Replace if broken, cracked, or threads damaged
INSTALLATION				
5	Engine, right hand side, rear	a. Dipstick tube (8), top	Position	At engine
		b. Bracket (7)	Install	Over dipstick tube (8)
		c. Capscrew (5) and lock washer (6)	Install	Do not tighten
		d. Capscrew (2), lock washer (3), and nut (5)	Install and tighten	
6	Transmission oil pan, right hand side	a. Dipstick tube (8)	Position	In transmission oil pan opening
		b. Nut (1)	Tighten	
7	Engine, right hand side, rear	a. Capscrew (5)	Tighten	
		b. Transmission fluid	Fill and check level	Para 2-41b
		c. Dipstick	Install	Para 2-41b
8	Cab tilt pump	Cab	Lower	To normal operating position

NOTE

Operate tractor and check for fluid leaks at nut (1). Tighten nut (1) or replace parts as necessary to prevent leakage.

2-42. PROPELLER SHAFT MAINTENANCE

- This task covers:
- a. Servicing
 - b. Removal
 - c. Disassembly
 - d. Cleaning
 - e. Inspection
 - f. Reassembly
 - g. Installation

INITIAL SETUP

Tools

No. 1 Common Organizational Maintenance

Tool Kit

- Scratch wire brush
- Safety glasses
- Socket wrench set
- Mechanical puller kit
- Cold chisel

Automotive Mechanic's Tool Kit

- Pliers
- Hammer
- Center punch
- Drive pin punch

Lubricating kit

- Grease gun

Brass drift

Materials/Parts

- Cleaning solvent Item 1, Appendix C
- Clean cloths Item 2, Appendix C

- Grease Item 3, Appendix C
- Mineral spirits Item 33, Appendix C
- Penetrating oil Item 44, Appendix C
- Eight lockstraps FSCM 72447 PN 230323
- Cork washer FSCM 72447 PN 6-16-123

Personnel Required

Wheel Vehicle Mechanic MOS 63B

Equipment Condition

Paragraph	Condition Description
	Parked on level surface; parking brake applied; wheels blocked; engine off.
2-63e	5th wheel boom platform removed.
2-65c	Rear platform removed.

STEP	LOCATION	ITEM	ACTION	REMARKS
------	----------	------	--------	---------

SERVICING

1	Drive shaft	Three lubrication fittings (16, 17, and 18)	a. Clean b. Lubricate	Use clean cloth and remove dirt and grease Drive shaft shall be lubricated monthly with grease
---	-------------	---	--------------------------	---

REMOVAL

CAUTION

Do not allow bearings to fall off drive shaft spiders (11 and 12) while removing the drive shaft from the transmission and differential yokes.

NOTE

Apply penetrating oil to bearing races (6) and caps to facilitate removal.

2-42. PROPELLER SHAFT MAINTENANCE (CONT)

KEY

- 1. Capscrews (8)
- 2. Lockstraps (4)
- 3. Bearing races (4)
- 4. Capscrews (8)
- 5. Lockstraps (4)
- 6. Bearing races (4)
- 7. Splined shaft
- 8. Sleeve tube
- 9. Transmission yoke
- 10. Differential yoke
- 11. Spider
- 12. Spider
- 13. Dust cap
- 14. Washer
- 15. Cork washer
- 16. Lubrication fitting
- 17. Lubrication fitting
- 18. Lubrication fitting

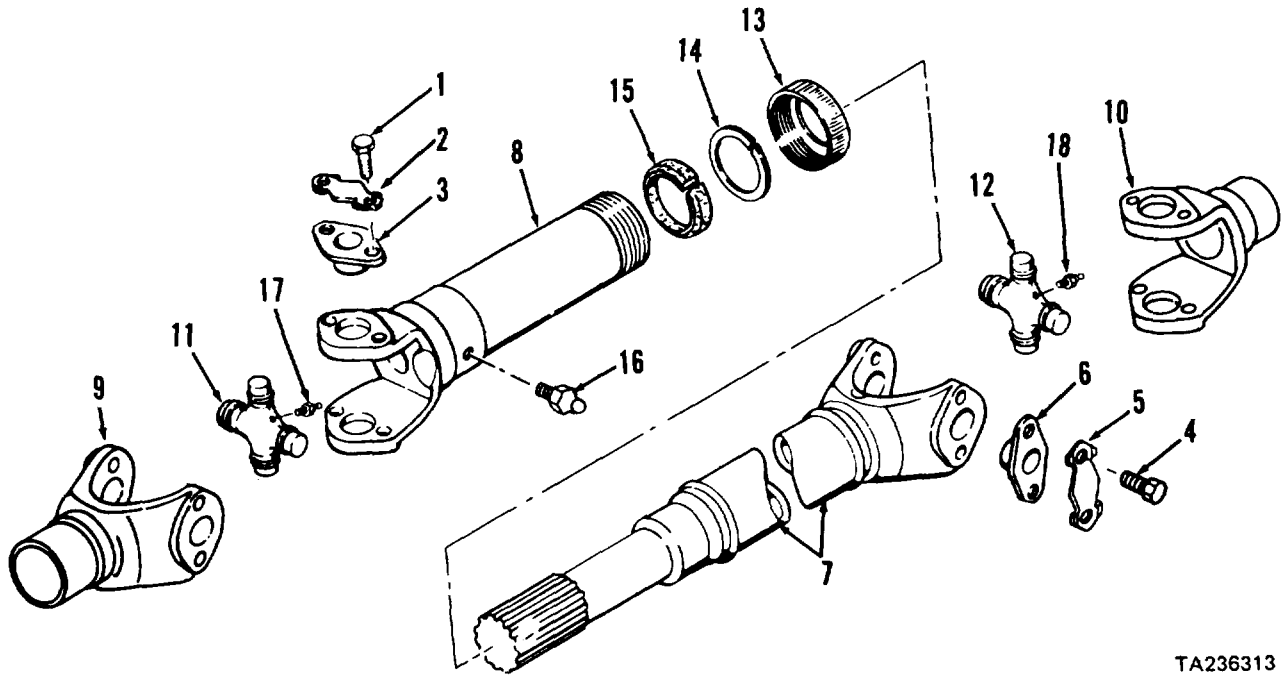
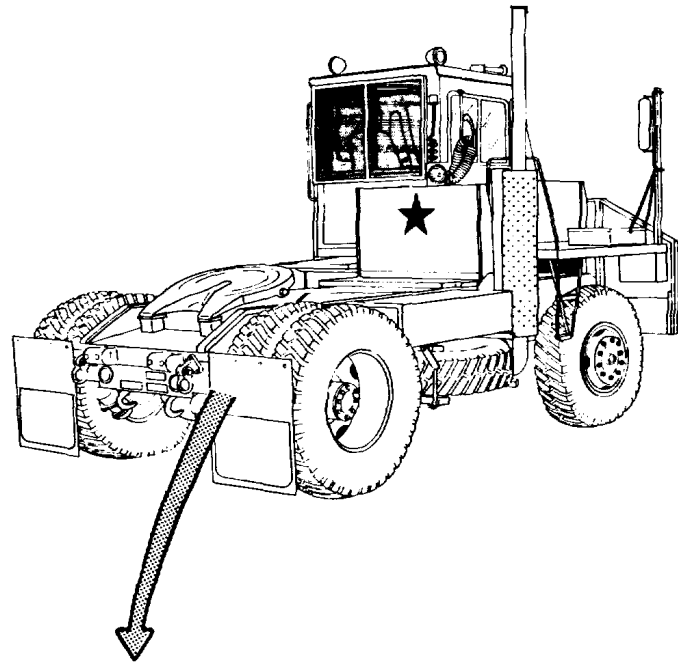

TA236313

2-42. PROPELLER SHAFT MAINTENANCE (CONT)

STEP	LOCATION	ITEM	ACTION	REMARKS
REMOVAL (cont)				
2	Transmission yoke (9)	a. Sleeve tube (8)	Support	
		b. Lubrication fitting (17)	Remove	
		c. Two lockstraps (2)	Bend tabs down	Opposite each other
		d. Four capscrews (1)	Remove	
		e. Two lockstraps (2)	Remove and discard	
NOTE				
Remove only two bearing races from each end, so as to keep the spiders (11 and 12) with the drive shaft.				
3	Differential yoke (10)	f. Two bearing races (3)	Remove	Turn cap using brass drift and hammer and pull using mechanical puller kit
		a. Lubrication fitting (18)	Remove	
		b. Two lockstraps (5)	Bend tabs down	Opposite each other
		c. Four capscrews (4)	Remove	
		d. Two lockstraps (5)	Remove and discard	
		e. Two bearing races (6)	Remove	
f. Splined shaft (7) and sleeve tube (8)	a. Scribe	Scribe alignment mark to aid in reassembly		
	b. Compress			
	c. Remove	Detach from transmission yoke (9) and differential yoke (10); remove drive shaft from tractor		
DISASSEMBLY				
4	Sleeve tube (8)	a. Remaining capscrews (1), lockstraps (2), and bearing races (3)	Remove; discard lockstraps (2)	
		b. Spider (11)	Remove	

2-42. PROPELLER SHAFT MAINTENANCE (CONT)

STEP	LOCATION	ITEM	ACTION	REMARKS
DISASSEMBLY (cont)				
5	Splined shaft (7)	a. Remaining cap-screws (4), lockstraps (5), and bearing races (6)	Remove; discard lockstraps	
		b. Spider (12)	Remove	
		c. Dust cap (13)	Unscrew	Then slide up on splined shaft (7)
		d. Splined shaft (7)	Remove	From sleeve tube (8)
		e. Washer (14)	Remove	
		f. Cork washer (15)	Remove and discard	
		g. Dust cap (13)	Remove	From splined shaft (7)
		h. Lubrication fitting (16)	Remove	From sleeve tube (8)
CLEANING				
6		a. Spiders (11 and 12) and bearings	Clean	Use mineral spirits; dry with clean cloths

WARNING

Dry cleaning solvent (P-D-680), used to clean parts is toxic and flammable. Wear protective goggles and gloves and use only in a well ventilated area. Avoid contact with skin, eyes, and clothes and don't breathe vapors. Do not use near open flame or excessive heat and don't smoke when using it. Failure to do so could cause serious injury. If you become dizzy while using cleaning solvent, get fresh air and medical attention immediately. If contact with skin or clothes is made, flush with large amounts of water. If contact with eyes is made, wash eyes with water and seek medical aid immediately.

Compressed air must not exceed 30 psi. Wear safety glasses when drying parts with compressed air. Failure to do so could cause serious injury to eyes and possible blindness. If you hurt your eyes or if a foreign object is blown into your eyes, seek medical attention immediately.

2-42. PROPELLER SHAFT MAINTENANCE (CONT)

STEP	LOCATION	ITEM	ACTION	REMARKS
CLEANING (cont)				
6 (cont)		b. All other parts	Clean	Use cleaning solvent P-D-680 and stiff bristled brush; dry with compressed air or clean cloths
INSPECTION				
7		a. Splined shaft (7) and sleeve tube (8)	Inspect	Replace if cracked, broken, distorted, or if splines or threads damaged
		b. Spiders (11 and 12) and bearings	Inspect	Replace if cracked, broken, worn, or bearings loose or rough
		c. All other parts distorted, or threads damaged	Inspect	Replace if cracked, broken,
REASSEMBLY				
8	Splined shaft (7)	a. Dust cap (13)	Install	Then slide up shaft
		b. Washer (14)	Install	
		c. New cork washer (15)	Install	
		d. Lubrication fitting (16)	Install	If removed
		e. Splined shaft (7)	a. Align	With alignment mark on sleeve tube (8)
			b. Install	In sleeve tube (8)
		f. Dust cap (13)	Tighten	
		g. Spider (12)	Install	In splined shaft (7)
		h. Two bearing races (6), new lockstraps (5), and four capscrews (4)	Install	
		i. Lockstraps (5)	Bend tabs up	

2-42. PROPELLER SHA.FT MAINTENANCE (CONT)

STEP	LOCATION	ITEM	ACTION	REMARKS
REASSEMBLY (cont)				
9	Sleeve tube (8)	a. Spider (11) b. Two bearing races (3), new lockstraps (2), and four capscrews (1) c. Lockstraps (2)	Install Install Bend tabs up	In sleeve tube (8)

INSTALLATION

WARNING

Dry cleaning solvent (P-D-680), used to clean parts is toxic and flammable. Wear protective goggles and gloves and use only in a well ventilated area. Avoid contact with skin, eyes, and clothes and don't breathe vapors. Do not use near open flame or excessive heat and don't smoke when using it. Failure to do so could cause serious injury. If you become dizzy while using cleaning solvent, get fresh air and medical attention immediately. If contact with skin or clothes is made, flush with large amounts of water. If contact with eyes is made, wash eyes with water and seek medical aid immediately.

10	Transmission yoke (9) and differential yoke (10)	a. Yokes b. Drive shaft	Clean Position	Wipe with clean cloths moistened with cleaning solvent P-D-680; dry with clean cloth
11	Differential yoke (10)	a. Two bearing races (6), new lockstraps (5), and four capscrews (4) b. Lockstraps (5) c. Lubrication fitting (18)	Install Bend tabs up Install	

2-42. PROPELLER SHAFT MAINTENANCE (CONT)

STEP	LOCATION	ITEM	ACTION	REMARKS
INSTALLATION (cont)				
12	Transmis- sion	a. Two bearing races (3), new lock- straps (2), and four capscrews (1) b. Lockstraps (2) c. Lubrication fitting (17)	Install Bend tabs up Install	
13	Drive shaft assembly	Drive shaft	Lubricate	Use grease gun and grease at lubrication fittings
14	Tractor, rear	Rear platform	Install	Para 2-65c
15	5th wheel boom	Boom platform	Install	Para 2-63e

2-43. FRONT AXLE MAINTENANCE

a. Servicing. This task covers lubrication of the front axle.

INITIAL SETUP

Tools

No. 2 Common Organizational Maintenance Tool Kit
Grease gun

Materials/Parts

Clean cloths Item 2, Appendix C
Grease Item 3, Appendix C
Axle lubricant Item 6, Appendix C

Personnel Required

Wheel Vehicle Mechanic MOS 63B

Equipment Condition

Paragraph	Condition Description
	Parked on level surface; parking brake applied; engine off. (NOTE: If outside temperature is below freezing, park tractor in heated space for 1/2 hour before lubricating.)

KEY

1. Rubber plug
2. Sight glass
3. Upper grease fitting
4. Lower grease fitting

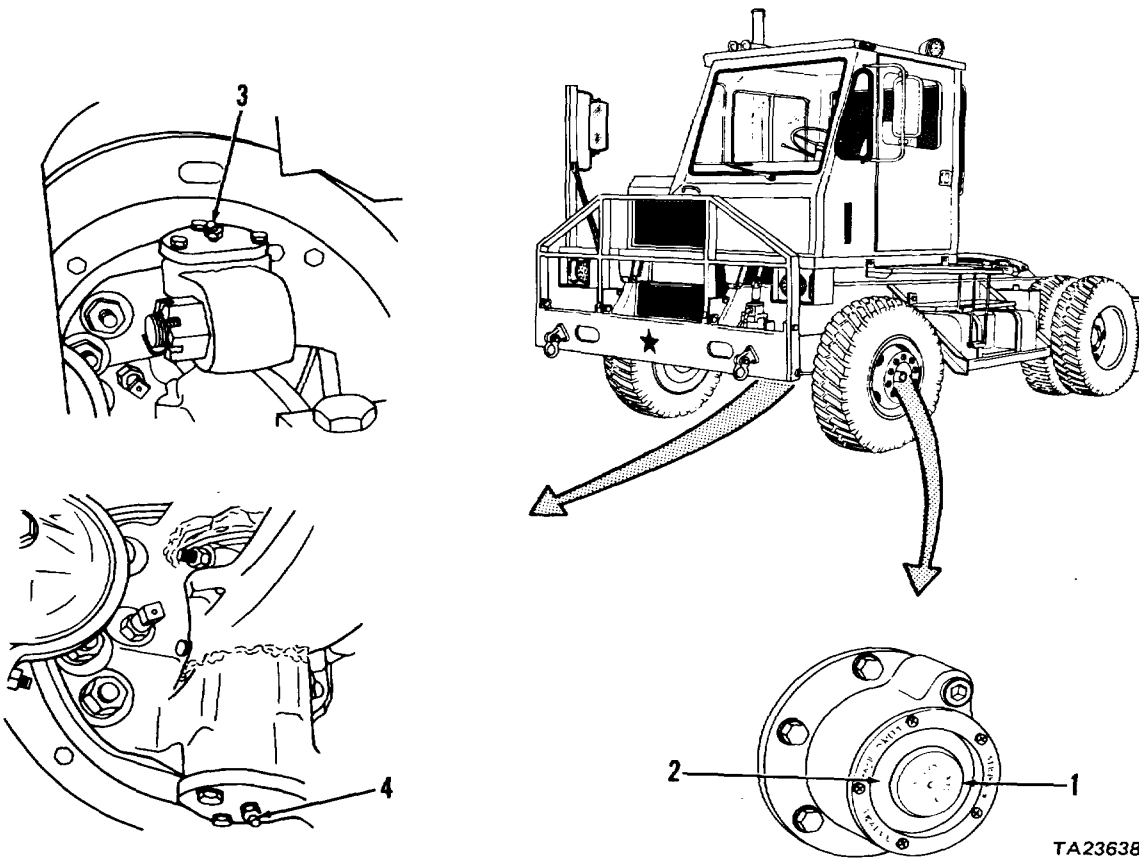

TA236382

2-43. FRONT AXLE MAINTENANCE (CONT)

a. Servicing (cont).

STEP	LOCATION	ITEM	ACTION	REMARKS
SERVICING				
1	Front axle, left side	a. Rubber plug (1)	Remove	Pull out
		b. Axle hub seal	Lubricate	Use axle lubricant. Maintain to OIL LEVEL mark at bottom of sight glass (2)
		c. Rubber plug (1)	Install	Push in
NOTE Repeat step 1 on right side of front axle.				
2	Front axle, left side, steering knuckle	Upper and lower grease fittings (3 and 4)	a. Clean	Use clean cloth to remove all dirt and old grease
			b. Lubricate	Use grease and grease gun; inject new grease until old grease pushes out

NOTE
Repeat step 2 on right side of tractor.

2-502

2-43. FRONT AXLE MAINTENANCE (CONT)

b. Hub and Drum.

This task covers: a. Removal c. Inspection
 b. Cleaning d. Installation

INITIAL SETUP

Tools

No. 1 Common Organizational Maintenance

Tool Kit

- Safety glasses
- Mechanical puller kit
- Socket wrench set
- Torque wrench

Automotive Mechanic's Tool Kit

Hammer

Arbor press

Sleeve

- Crocus cloth Item 12, Appendix C
- Wheel bearing grease Item 16, Appendix C
- Gasket FSCM 78500 PN 2208M819
- Oil seal assembly FSCM 78500 PN A1205X1428
- Wood block

Personnel Required

Wheel Vehicle Mechanic MOS 63B

Materials/Parts

Cleaning

solvent Item 1, Appendix C

Clean cloths Item 2, Appendix C

Light machine oil Item 7, Appendix C

Non-hardening sealant Item 10, Appendix C

Equipment Condition

Paragraph	Condition Description
	Parked on level surface; engine off.
	Rear wheels blocked.
	Tractor front supported.
2-57	Front wheels and tires removed

STEP	LOCATION	ITEM	ACTION	REMARKS
------	----------	------	--------	---------

REMOVAL

WARNING

Before performing the following step, be sure that chassis is securely supported by jack stands. Failure to do so could cause chassis to fall on you causing serious injury or death.

STEP	LOCATION	ITEM	ACTION
1	Right front axle end	a. Brake drum (1)	Remove
		b. Six capscrews (2) and washers (3)	Remove
		c. Hub cap assembly (4)	Remove
		d. Gasket (5)	Remove and discard
		e. Washer (8)	Bend away from nut (7)

2-43. FRONT AXLE MAINTENANCE (CONT)

b. Hub and Drum (cont).

KEY

1. Brake drum
2. Capscrews (6)
3. Washers (6)
4. Hub cap assembly
5. Gasket
6. Wear ring
7. Outer wheel bearing nut
8. Washer
9. Washer
10. Inner wheel bearing nut
11. Hub
12. Outer bearing cone
13. Inner bearing cone
14. Oil seal
15. Outer bearing cup
16. Inner bearing cup
17. Wheel studs (10)

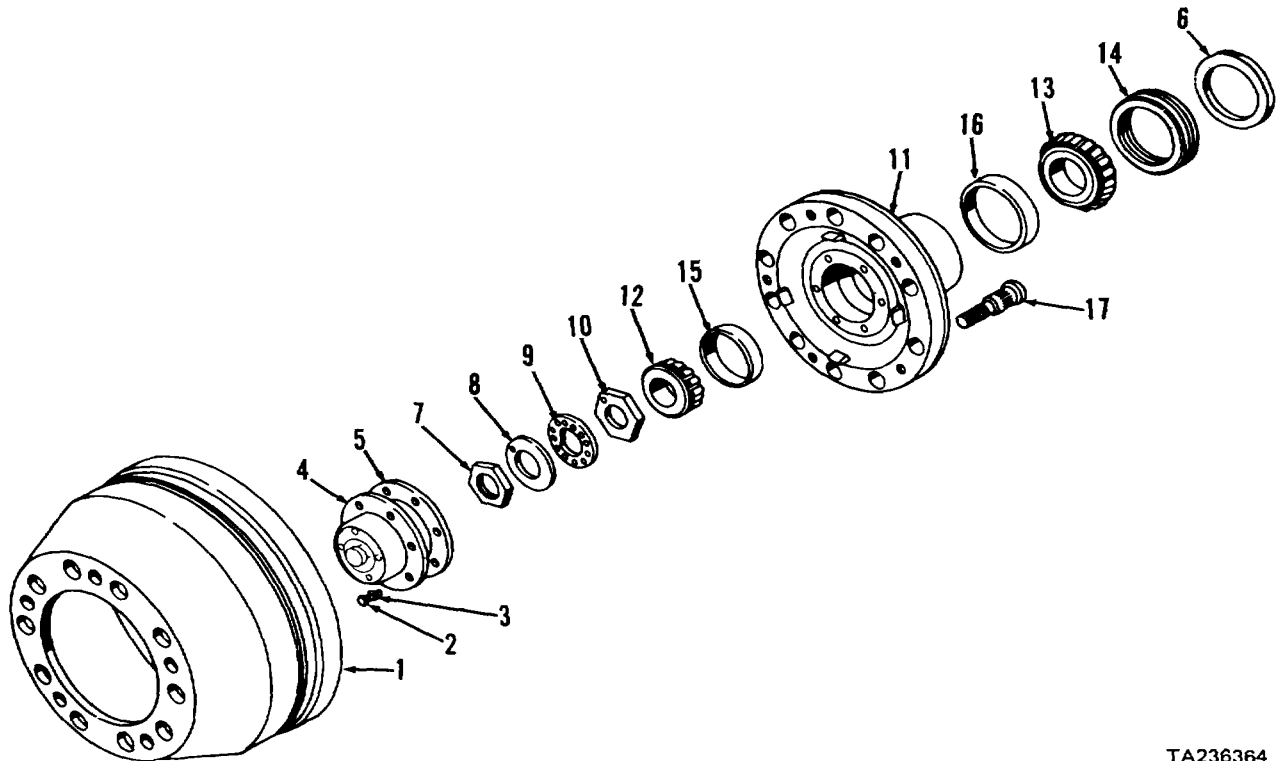
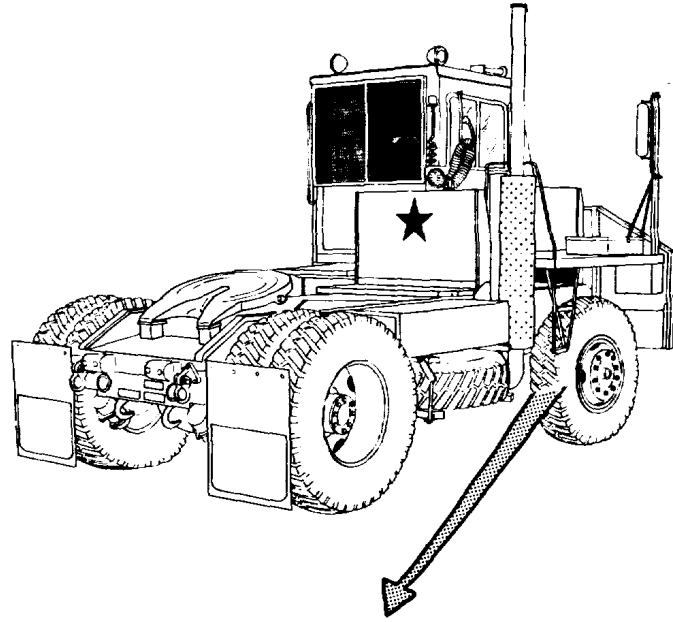

TA236364

2-43. FRONT AXLE MAINTENANCE (CONT)

b. Hub and Drum (cont).

STEP	LOCATION	ITEM	ACTION	REMARKS
REMOVAL (cont)				
1 (cont)		f. Outer wheel bearing nut (7) and washers (8 and 9)	Remove	
		g. Inner wheel bearing nut (10)	Remove	
		h. Hub (11)	Pull out	To loosen outer bearing cone (12); do not let outer bearing cone fall
		i. Outer bearing cone (12)	Remove	
		j. Hub (11)	Remove	From spindle
2	Axle spindle	Wear ring (6)	Remove	Only if inspection indicates replacement is necessary; use puller to remove
3	Hub (11)	a. Oil seal (14)	Remove and discard	
		b. Inner bearing cone (13)	Remove	
		c. Outer bearing cup (15)	Remove	Use hammer and drift on outer diameter of bearing cup to remove
		d. Inner bearing cup (16)	Remove	Use hammer and drift on outer diameter of bearing cup to remove
		e. 10 wheel studs (17)	Remove	Only if inspection indicates replacement is necessary

NOTE

Perform steps 1 thru 3 above to remove remaining hub and drum.

2-43. FRONT AXLE MAINTENANCE (CONT)

b. Hub and Drum (cont).

STEP	LOCATION	ITEM	ACTION	REMARKS
------	----------	------	--------	---------

CLEANING

WARNING

Dry cleaning solvent (P-D-680), used to clean parts is toxic and flammable. Wear protective goggles and gloves and use only in a well ventilated area. Avoid contact with skin, eyes, and clothes and don't breathe vapors. Do not use near open flame or excessive heat and don't smoke when using it. Failure to do so could cause serious injury. If you become dizzy while using cleaning solvent, get fresh air and medical attention immediately. If contact with skin or clothes is made, flush with large amounts of water. If contact with eyes is made, wash eyes with water and seek medical aid immediately.

Compressed air must not exceed 30 psi. Wear safety glasses when drying parts with compressed air. Failure to do so could cause serious injury to eyes and possible blindness. If you hurt your eyes or if a foreign object is blown into your eyes, seek medical attention immediately.

4		a. Brake drum (1) and hub (11)	Clean	Wipe with clean cloth moistened with cleaning solvent P-D-680. Dry using clean cloth
		b. Outer bearing cone (12) and inner bearing cone (13)	Clean	Immerse in cleaning solvent P-D-680 and slowly move up and down. Remove from solvent and strike large side of cone flat against block of wood to dislodge solidified particles of lubricant. Immerse in solvent and repeat above operation until thoroughly clean. Dry using moisture free compressed air. Direct air stream across bearing to avoid spinning. Do not spin bearings when drying them. Bearings may be rotated by hand to facilitate drying
		c. Remaining parts	Clean	Use cleaning solvent P-D-680

2-43. FRONT AXLE MAINTENANCE (CONT)

b. Hub and Drum (cont).

STEP	LOCATION	ITEM	ACTION	REMARKS
INSPECTION				
5		a. Brake drum (1)	Inspect for: cracks deep scores warpage damage	Replace as necessary
		b. Hub cap assembly (4)	Inspect for: distortion damage	Replace as necessary cracks
		c. Hub (11)	Inspect for: cracks distortion pitting damage	Replace as necessary; touch up minor surface irregularities by polishing surface with crocus cloth
		d. Outer bearing cone (12) and inner bearing cone (13)	Inspect for: wear chips nicks flat spots	Replace as necessary; replace associated bearing cup when replacing cone. After inspection, dip bearings in light oil and wrap in clean lintless cloth or paper until installed
		e. Outer bearing cup (15) and inner bearing cup (16)	Inspect for: cracks distortion damage	Replace as necessary
		f. Wheel studs (17)	Inspect for: cracks breaks distortion damaged threads	Replace as necessary
INSTALLATION				
6	Hub (11)	a. 10 wheel studs (17)	Install, if removed	Press into hub (11)
		b. Inner bearing cup (16) and outer bearing cup (15)	Install	Press into hub (11) until fully bottomed using proper size sleeve
		c. Inner bearing cone (13)	a. Lubricate b. Install	Use wheel bearing lubricant In hub (11)
		d. New oil seal (14)	Install	In hub (11)

2-43. FRONT AXLE MAINTENANCE (CONT)

b. Hub and Drum (cont).

STEP	LOCATION	ITEM	ACTION	REMARKS
INSTALLATION (cont)				
7	Axle spindle	a. Axle spindle, seal area	Seal	Apply bead of non-hardening sealant around edge of seal area
		b. Wear ring (6)	Install, if removed	Large diameter side to spindle
		c. Hub (11)	Install	
		d. Outer bearing cone (12)	a. Lubricate	Use wheel bearing lubricant
		e. Inner wheel bearing nut (10)	b. Install	In hub (11)
			Install, tighten, loosen, and retighten	Dowel on nut must be facing outward. Tighten to 100 pounds foot torque while rotating hub (11) in both directions. Back-off nut 1/2 to one full turn then tighten to 50 pounds foot torque
		f. Washer (9)	Install	Hole in washer (9) must engage nut (10) dowel pin
		g. Washer (8)	Install	Dimple in washer (8) must be aligned with one hole in washer (9)
		h. Outer wheel bearing nut (7)	Install	Tighten to 200-300 pounds foot torque
		i. Washer (8)	Bend over	Against one flat of nut (7)
		j. New gasket (5)	Position	On hub (11)
		k. Hub cap assembly (4)	Position	On gasket (5)
		l. Six washers (3) and capscrews (2)	Install	Tighten to 25 pounds foot torque
		m. Brake drum (1)	Install	
8	Right front hub	Hub cap assembly (1)	Lubricate	Para 2-43a
9	Front axle, right side	Right front wheel	Install	Para 2-57
10	Tractor	Front	Lower to ground	

NOTE

Perform steps 6 thru 10 above to install remaining hub and drum.

2-44. REAR AXLE MAINTENANCE

a. Servicing. This task covers lubrication of the rear axle.

INITIAL SETUP

Tools

No. 1 Common Organizational Maintenance

Tool Kit

Adjustable open end wrench

Socket wrench set

Safety glasses

5-gallon container

Roller jack

Materials/Parts

Cleaning solvent Item 1, Appendix C

Clean cloths Item 2, Appendix C

Axle lubricant Item 6, Appendix C

Personnel Required

Wheel Vehicle Mechanic MOS 63B

References

LO 9-2320-285-12

(M878A1 Lubrication Order)

Equipment Condition

Paragraph	Condition Description
-----------	-----------------------

	Parked on level surface; parking brake applied; engine off.
--	---

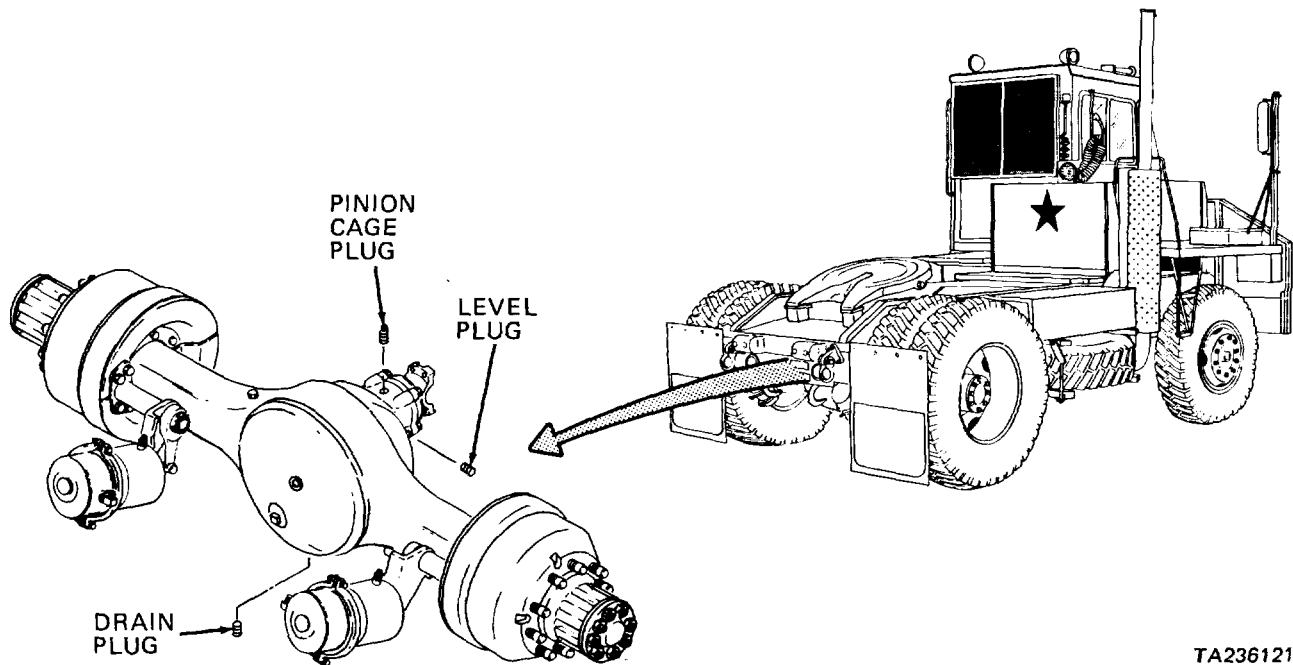

TA236121

2-44. REAR AXLE MAINTENANCE (CONT)

a. Servicing (cont).

STEP	LOCATION	ITEM	ACTION	REMARKS
SERVICING				
1	Rear axle, bottom center	a. 5-gallon container	Position	Under rear axle drain plug
		b. Drain plug	Loosen and remove	From bottom of rear axle housing
		c. Axle lubricant	Drain	Allow to drain completely

WARNING

Dry cleaning solvent (P-D-680), used to clean parts is toxic and flammable. Wear protective goggles and gloves and use only in a well ventilated area. Avoid contact with skin, eyes, and clothes and don't breathe vapors. Do not use near open flame or excessive heat and don't smoke when using it. Failure to do so could cause serious injury. If you become dizzy while using cleaning solvent, get fresh air and medical attention immediately. If contact with skin or clothes is made, flush with large amounts of water. If contact with eyes is made, wash eyes with water and seek medical aid immediately.

2	Pinion cage, top	d. Drain plug	a. Clean	Remove metal chips from magnetic end; then clean with cloth moistened in cleaning solvent P-D-680 and dry with clean cloth
		e. 5-gallon container	b. Install Remove	Tighten securely Dispose of used lubricant properly
		a. Pinion cage plug	Loosen and remove	Only if carrier assembly is new or recently rebuilt
		b. Axle lubricant	Install	Pour 1/2 pint through pinion cage plug opening to provide initial lubrication for pinion
		c. Pinion cage plug	Install	Tighten securely

2-44. REAR AXLE MAINTENANCE (CONT)

a. Servicing (cont).

STEP	LOCATION	ITEM	ACTION	REMARKS
SERVICING (cont)				
3	Pinion cage, right side	a. Level plug	Loosen and remove	
		b. Axle lubricant	Install	Pour in level plug opening until lubricant level is even with bottom of plug opening (refer to current lubrication order)
		c. Level plug	Install	Tighten securely
4	Rear axle	a. Jack	a. Raise	Several inches, one side of rear axle at a time to allow lubricant to run into axle hubs
		b. Level plug	b. Remove Loosen and remove	
		c. Axle lubricant	Check level	See step 3b above
		d. Level plug	Install	Tighten securely

2-44. REAR AXLE MAINTENANCE (CONT)

b. Axle Shafts, Hubs, and Drums.

This task covers: a. Removal/Disassembly
b. Cleaning

c. Inspection
d. Reassembly/Installation

INITIAL SETUP

Tools

No. 1 Common Organizational Maintenance

Tool Kit

- Socket wrench set
- Torque wrench
- Adjustable open end wrench
- Hammer
- Safety glasses

Brass drift, 1-1/2 inch diameter

Jack

Two jack stands

Materials/Parts

- Cleaning solvent Item 1, Appendix C
- Clean cloths Item 2, Appendix C
- Non-hardening sealant 2-57
- Item 10, Appendix C 2-44a
- No. 2 lithium grease Item 16, Appendix C 2-51d(2)
- Two gaskets FSCM 78500 PN 2208X440

Personnel Required

Wheel Vehicle Mechanic MOS 63B

References

LO 9-2320-285-12
(M878A1 Lubrication Order)

Equipment Condition

Paragraph Condition Description

Parked on level surface; parking brake applied; engine off. Front wheels blocked. Rear of chassis raised and supported on jack stands. Rear wheels and tires removed. Rear axle housing drained; drain plug installed. Parking (spring) brakes caged.

STEP	LOCATION	ITEM	ACTION	REMARKS
------	----------	------	--------	---------

REMOVAL/DISASSEMBLY

1	Rear axle, left side	a. Eight nuts (1) and lock washers (2)	Remove	
---	----------------------	--	--------	--

WARNING

Don't strike hardened steel parts with steel hammer. To do so could cause metal chips to hit your eyes causing you serious injury. Seek medical attention immediately if you get metal chips in your eyes. Always wear safety glasses when using a hammer.

CAUTION

Do not strike studs (18) since this may cause them to break and splinter. Do not use chisel or wedge to loosen axle shaft (4) or tapered sleeves (3) since this will damage axle shaft.

2-44. REAR AXLE MAINTENANCE (CONT)

b. Axle Shafts, Hubs, and Drums (cont).

KEY

- 1. Nuts (8)
- 2. Lock washers (8)
- 3. Tapered sleeves (8)
- 4. Axle shaft
- 5. Gasket
- 6. Outer nut
- 7. Locking washer
- 8. Inner nut
- 9. Hub
- 10. Brake drum
- 11. Outer cone
- 12. Oil seal
- 13. Steel retainer
- 14. Inner cone
- 15. Inner cup
- 16. Outer cup
- 17. Studs (10)
- 18. Studs (8)
- 19. Wear ring

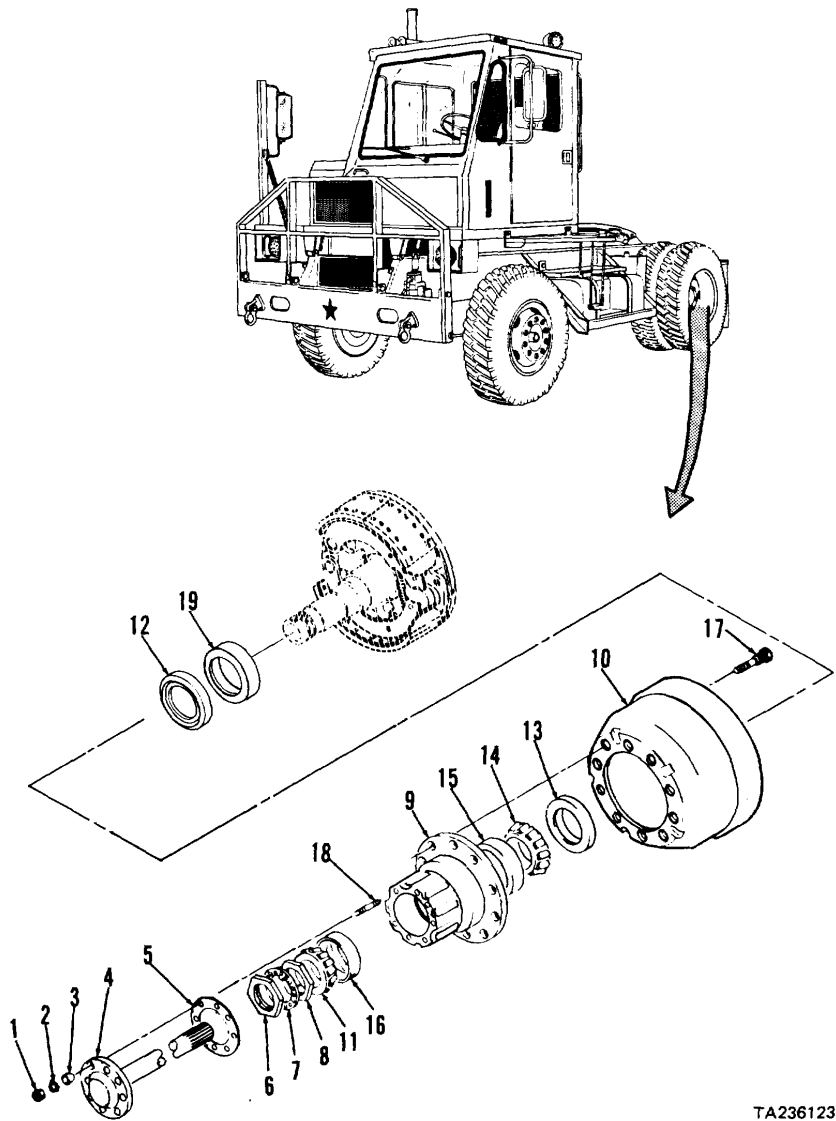

TA236123

2-44. REAR AXLE MAINTENANCE (CONT)

b. Axle Shafts, Hubs, and Drums (cont).

STEP	LOCATION	ITEM	ACTION	REMARKS
REMOVAL/DISASSEMBLY (cont)				
1 (cont)		b. Axle shaft (4)	Tap	Place 1-1/2 inch diameter brass drift against center of axle shaft and strike sharply with hammer to loosen tapered sleeves (3)
		c. Eight tapered sleeves (3)	Remove	Pull from studs (18)
NOTE				
Right and left axle shafts (4) are not interchangeable. Mark end of axle shaft to aid installation.				
		d. Axle shaft (4)	Remove	Pull from housing
		e. Gasket (5)	Remove and discard	From axle shaft (4) or hub (9)
2	Hub (9)	a. Nuts (6 and 8) with locking washer (7)	Remove	
		b. Hub (9) with drum (10)	Remove	Do not let outer bearing cone (11) fall
		c. Outer cone (11)	Remove	From hub (9)
		d. Oil seal (12)	Remove	From steel retainer (13)
		e. Steel retainer (13), inner cone (14), and inner cup (15)	Remove	Drive out with brass drift and hammer
		f. Outer cup (16)	Remove	Drive out with brass drift and hammer
NOTE				
Do not remove studs (17 and 18) and brake drum (10) from hub (9) unless replacement is required.				
		g. 10 studs (17)	Remove	Press out
		h. Brake drum (10)	Separate	From hub (9)
		i. Eight studs (18)	Remove	Press from hub (9)
3	Axle housing end	Wear ring (19)	Remove	Use puller, only if replacement is required

2-44. REAR AXLE MAINTENANCE (CONT)

b. Axle Shafts, Hubs, and Drums (cont).

STEP	LOCATION	ITEM	ACTION	REMARKS
------	----------	------	--------	---------

REMOVAL/DISASSEMBLY (cont)

NOTE

Repeat steps 1 thru 3 above to remove and disassemble right hand axle shaft, hub, and drum.

CLEANING

WARNING

Dry cleaning solvent (P-D-680), used to clean parts is toxic and flammable. Wear protective goggles and gloves and use only in a well ventilated area. Avoid contact with skin, eyes, and clothes and don't breathe vapors. Do not use near open flame or excessive heat and don't smoke when using it. Failure to do so could cause serious injury. If you become dizzy while using cleaning solvent, get fresh air and medical attention immediately. If contact with skin or clothes is made, flush with large amounts of water. If contact with eyes is made, wash eyes with water and seek medical aid immediately.

Compressed air must not exceed 30 psi. Wear safety glasses when drying parts with compressed air. Failure to do so could cause serious injury to eyes and possible blindness. If you hurt your eyes or if a foreign object is blown into your eyes, seek medical attention immediately.

4	a. Bearing cones (11 and 14)	Clean	Use cleaning solvent P-D-680. Don't spin bearings with compressed air
	b. All other parts	Clean	Use cleaning solvent P-D-680; dry with compressed air

INSPECTION

5	a. Bearing cones (11 and 14)	Inspect	Replace if worn, chipped, or nicked. If bearing is to be replaced, replace mating bearing cup (16 or 15). Dip bearing cone in light oil after inspection
---	------------------------------	---------	--

2-44. REAR AXLE MAINTENANCE (CONT)

b. Axle Shafts, Hubs, and Drums (cont).

STEP	LOCATION	ITEM	ACTION	REMARKS
INSPECTION (cont)				
5 (cont)		b. Axle shaft (4)	Inspect	Replace if bent, twisted, splines worn or damaged, or flange distorted
		c. Brake drum (10)	Inspect	Replace if worn, scored, or cracked
		d. Hub (9)	Inspect	Replace if cracked; be sure all grease and dirt is removed from inside hub
		e. All other parts	Inspect	Replace if damaged, bent, distorted, or threads damaged
REASSEMBLY/INSTALLATION				
6	Axle housing end	a. Axle housing end, seal area	Seal	Apply bead of non-hardening sealant around edge of seal area
7	Hub (9)	b. Wear ring (19)	Install	Against hub (9), with holes aligned
		a. Brake drum (10)	Position, if necessary	
		b. 10 studs (17)	Install, if necessary	Press in
		c. Inner cup (15)	Install	Use brass drift
		d. Outer cup (16)	Install	Use brass drift
		e. Eight studs (18)	Install, if necessary	Screw in
8	Rear axle, left side	f. Inner cone (14)	a. Lubricate	Refer to current lubrication order
		g. Steel retainer (13)	b. Position	In inner cup (15)
			a. Seal	Apply bead of non-hardening sealant to outer diameter
		h. Oil seal (12)	b. Install	In steel retainer (13)
			a. Install	
		a. Hub (9) with drum (10)	b. Lubricate	Carefully, to prevent damage to oil seal (12)
			Install	
		b. Outer cone (11)	a. Lubricate	Refer to current lubrication order
b. Position	In outer cup (16)			

2-44. REAR AXLE MAINTENANCE (CONT)

b. Axle Shafts, Hubs, and Drums (cont).

STEP	LOCATION	ITEM	ACTION	REMARKS
REASSEMBLY/INSTALLATION (cont)				
8 (cont)		c. Inner nut (8)	a. Install	With locking dowel positioned outward
		b. Tighten		To 100 pounds foot; then back nut off, tighten to 50 pounds foot, and back nut off 1/6 turn
		d. Locking washer (7)	Position	Against inner nut (8)
		e. Outer nut (6)	Install and tighten	To 250-400 pounds foot
		f. New gasket (5)	Position	Over studs (18)

NOTE

Right and left axle shafts (4) are not interchangeable. Observe mark made during removal and install proper axle shaft in following step.

		g. Axle shaft (4)	Install	
		h. Eight tapered sleeves (3), lock washers (2), and nuts (1)	Install and tighten	Tighten nuts (1) to 130-165 pounds foot

NOTE

Repeat steps 6 thru 8 above to reassemble and install right hand axle shaft, hub, and drum.

9	Rear axle ends	Rear wheels and tires	Install	Para 2-57
10	Tractor frame, rear	a. Rear frame	Raise	Use jack
		b. Jack stands	Remove	From under tractor frame
		c. Rear tires	Lower	To ground; then remove jack
11	Rear axle	a. Lubricant	Install	Para 2-44a (After initial fill, raise each side of rear axle with jack several inches to allow lubricant to fill each hub. Then re-check rear axle oil level.)
		b. Parking brakes	Uncage	Para 2-51d(2)

Section VII. BRAKE SYSTEM MAINTENANCE

This section contains the information you'll need to maintain the:

- Service Brake System
- Air Brake System
- Air Compressor
- Trailer Brake Lines and Couplings

This section tells you how to troubleshoot problems, and repair or replace the components that are within the scope of organizational maintenance.

	Para
Troubleshooting Symptom Index.....	2-45
Service Brake System Troubleshooting	2-46
Air Brake System Troubleshooting.....	2-47
Air Compressor Troubleshooting.....	2-48
Trailer Brake Lines and Couplings	
Troubleshooting.....	2-49
Service Brake System Maintenance	2-50
Front Axle Brakes.....	2-50a
Rear Axle Brakes	2-50b
Air Brake System Maintenance	2-51
Air Brake Lines and Fittings	2-51a
Air Reservoirs.....	2-51b
Low Air Pressure Switch.....	2-51c
Brake Air Chambers.....	2-51d
Front Axle Brakes Air Chambers.....	2-51d(1)
Rear Axle Brakes Air Chambers	2-51d(2)
Air Compressor Assembly Maintenance	2-52
Servicing (Summary Procedure) 2-52a	
Air Strainer	2-52b
Alcohol Evaporator	2-52c
Air Compressor Governor	2-52d
Air Compressor Assembly	2-52e
Trailer Brake Lines and Couplings	2-53
Trailer Brake Lines and Couplings	2-53a
Hose Tender.....	2-53b

2-45. TROUBLESHOOTING SYMPTOM INDEX

	Para/Malfunction	Page
SERVICE BRAKE SYSTEM		
Front or rear axle brakes release slowly	2-46/1	2-520
Uneven or erratic front axle brakes	2-46/2	2-520
Uneven or erratic rear axle brakes	2-46/3	2-521
Front axle brakes automatic adjustment not operating	2-46/4	2-522
Front axle brakes dragging	2-46/5	2-523
Rear axle brakes dragging	2-46/6	2-524
Front axle brakes grabbing.....	2-46/7	2-526
Rear axle brakes grabbing	2-46/8	2-526
Front axle brakes linings wear unevenly	2-46/9	2-527
Rear axle brakes linings wear unevenly	2-46/10	2-528
Front axle brakes frozen or locked	2-46/11	2-529
Rear axle brakes frozen or locked	2-46/12	2-529
Insufficient brake force to stop vehicle (front axle brakes)	2-46/13	2-530
Insufficient brake force to stop vehicle (rear axle brakes)	2-46/14	2-531
Front axle brakes squeak or groan, or scraping noise when applied	2-46/15	2-531
Rear axle brakes squeak or groan, or scraping noise when applied	2-46/16	2-532
AIR BRAKE SYSTEM		
Rapid pressure drop after engine is shut down (brakes released)	2-47/1	2-533
Rapid pressure drop after engine is shut down (brakes applied).....	2-47/2	2-533
Pressure builds up slowly	2-47/3	2-534
Pressure won't build up to normal	2-47/4	2-534
Parking (spring) brakes won't release	2-47/5	2-535
AIR COMPRESSOR		
Pressure too high, or air compressor won't cut out.....	2-48/1	2-535
Pressure builds up slowly	2-48/2	2-535
Air compressor knocks	2-48/3	2-536
TRAILER BRAKE LINES AND COUPLINGS		
Trailer brakes do not release	2-49/1	2-536
Trailer service brakes do not function (cab guard).....	2-49/2	2-537
Trailer service brakes do not function (rear of tractor)	2-49/3	2-538

2-46. SERVICE BRAKE SYSTEM TROUBLESHOOTING

MALFUNCTION
TEST OR INSPECTION
CORRECTIVE ACTION

1. FRONT OR REAR AXLE BRAKES RELEASE SLOWLY

Check air brake system for obstructed lines and fittings.

WARNING

Compressed air must not exceed 30 psi. Wear safety glasses when using compressed air. Failure to do so could cause serious injury to eyes and possible blindness. If you hurt your eyes or if a foreign object is blown into your eyes, seek medical aid immediately.

- a. If lines or fittings are obstructed, clear using compressed air (30 psi maximum) in reverse of normal air flow. If line or fitting remains obstructed, replace (para 2-51a).
- b. If lines and fittings are not obstructed, notify direct support maintenance.

2. UNEVEN OR ERRATIC FRONT AXLE BRAKES

Step 1. Check if air pressure in each tire is 120 psi.

- a. If air pressure in tire is not 120 psi, adjust tire pressure.
- b. If air pressure in each tire is 120 psi, go to step 2 below.

Step 2. Check brake drum-to-lining clearance (para 2-50a).

- a. If clearance is excessive, adjust brakes (para 2-50a); then retest for proper operation. If front axle brakes operation remains uneven or erratic, go to step 3 below.
- b. If clearance is not excessive, go to step 3 below.

Step 3. Remove brake drums (para 2-44a).
Check brake shoe linings for wear, uneven glaze, lubricant contamination, or excessive dust.

WARNING

Brake linings contain asbestos fibers. Do not generate dust when working on brake system. Do not remove dust or dirt with compressed air because serious bodily harm may result from breathing asbestos dust.

- a. Replace brake shoe linings if worn, glazed, or contaminated (para 2-50a); remove excessive dust.

2-46. SERVICE BRAKE SYSTEM TROUBLESHOOTING (CONT)

MALFUNCTION
TEST OR INSPECTION
CORRECTIVE ACTION

2. UNEVEN OR ERRATIC FRONT AXLE BRAKES (Cont)

- Step 3. b. If brake shoe linings are okay, go to step 4 below.
(cont)
- Step 4. Check brake drums for scored, cracked, or warped condition.
- a. If brake drums are scored, cracked, or warped, replace (para 2-44a).
- b. If brake drums are not scored, cracked, or warped, go to step 5 below.
- Step 5. Remove front axle brakes air chambers (para 2-51d(1)).
Remove wedge assembly (para 2-50a).
Check front axle brakes air chambers and wedge assembly for damage or wear.
- a. If front axle brakes air chambers or wedge assembly are damaged or worn, replace (para 2-50a or 2-51d(l)).
- b. If front axle brakes air chambers and wedge assembly are not damaged or worn, go to step 6 below.
- Step 6. Disassemble front axle brakes (para 2-50a).
Check plungers for wear, damage, or sticking.
- If plungers are worn, damaged, or sticking, repair or replace parts as required (para 2-50a).

3. UNEVEN OR ERRATIC REAR AXLE BRAKES

- Step 1. Check if air pressure in each tire is 120 psi.
- a. If air pressure in each tire is not 120 psi, adjust tire pressure.
- b. If air pressure in each tire is 120 psi, go to step 2 below.
- Step 2. With front wheels blocked and PARKING BRAKE valve pushed down fully, check brake drum-to-lining clearance (para 2-50a).
- a. If clearance is excessive, adjust brakes (para 2-50a); then retest for proper operation. If rear axle brakes operation remains uneven or erratic, go to step 3 below.
- b. If clearance is not excessive, go to step 3 below.

2-46. SERVICE BRAKE SYSTEM TROUBLESHOOTING (CONT)

MALFUNCTION
TEST OR INSPECTION
CORRECTIVE ACTION

3. UNEVEN OR ERRATIC REAR AXLE BRAKES (Cont)

- Step 3. Install release stud in rear axle brakes air chambers (para 2-51d(2)).
Remove brake drums (para 2-44b).
Check brake shoe and lining assemblies for wear, uneven glaze, lubricant contamination, or excessive dust.

WARNING

Brake linings contain asbestos fibers. Do not generate dust when working on brake system. Do not remove dust or dirt with compressed air because serious bodily harm may result from breathing asbestos dust.

- a. If brake shoe and lining assemblies are worn, glazed, or contaminated, replace (para 2-50b); remove excessive dust.
- b. If brake shoe and lining assemblies are not worn, glazed, or contaminated, go to step 4 below.

- Step 4. Check brake drums for scored, cracked, or warped condition.

- a. If brake drums are scored, cracked, or warped, replace (para 2-44b).
- b. If brake drums are not scored, cracked, or warped, go to step 5 below.

- Step 5. Remove rear axle brakes air chambers (para 2-51d(2)).
Remove slack adjuster, camshafts, rear axle brakes air chambers, and associated parts (para 2-50b or 2-51d(2)).
Check slack adjuster, camshafts, rear axle brakes air chambers, and associated parts for damage or wear.

If parts are damaged, replace (para 2-50b or 2-51d(2)).

4. FRONT AXLE BRAKES AUTOMATIC ADJUSTMENT NOT OPERATING

- Step 1. Remove brake drums (para 2-44a).
Remove brake shoes (para 2-50a) and check if adjusting bolt is frozen in plunger.
- a. If adjusting bolt is frozen in plunger, free it and coat plunger (inside and outside surfaces) with grease.
 - b. If adjusting bolt is not frozen in plunger, go to step 2 below.

2-46. SERVICE BRAKE SYSTEM TROUBLESHOOTING (CONT)
--

MALFUNCTION	TEST OR INSPECTION	CORRECTIVE ACTION
--------------------	---------------------------	--------------------------

4. FRONT AXLE BRAKES AUTOMATIC ADJUSTMENT NOT OPERATING (Cont)

- Step 2. Remove plungers (para 2-50a).
Check plungers for corrosion, inadequate lubrication, or improper position.
Check plungers and pawls for damage.
- a. If plungers are corroded, replace (para 2-50a).
 - b. If plungers are inadequately lubricated, lubricate (para 2-50a).
 - c. If plunger is not positioned properly, reposition (para 2-50a).
 - d. If plungers or pawls are damaged, replace (para 2-50a).

5. FRONT AXLE BRAKES DRAGGING

- Step 1. Check wheel bearing for proper adjustment (raise wheel and use pry bar to check for any noticeable end play) or damage.
Repeat for other wheel.
- a. If end play is noticeable, adjust or replace wheel bearing (para 2-44a).
 - b. If end play is not noticeable, go to step 2 below.
- Step 2. Remove brake drums (para 2-44a).
Remove brake shoes (para 2-50a) and check brake return springs for proper tension: spring tension shall be 75-90 pounds pull at 9-1/2 inches.
- a. If return springs do not have proper tension, replace (para 2-50a).
 - b. If return springs have proper tension, go to step 3 below.
- Step 3. Check if wedge assembly is out of front axle brake air chamber housing socket or is damaged.
- a. If wedge assembly is out of front axle brake air chamber housing socket, reinstall (para 2-50a); if wedge assembly is damaged, replace (para 2-50a).
 - b. If wedge assembly is installed properly and is not damaged, go to step 4.

2-46. SERVICE BRAKE SYSTEM TROUBLESHOOTING (CONT)

MALFUNCTION	TEST OR INSPECTION	CORRECTIVE ACTION
--------------------	---------------------------	--------------------------

5. FRONT AXLE BRAKES DRAGGING (Cont)

- | | | |
|---------|--|--|
| Step 4. | Remove plungers (para 2-50a).
Check plungers for corrosion, inadequate lubrication, or sticking.
Check seals for damage. | |
| | a. If plungers are corroded, replace (para 2-50a); if plungers are inadequately lubricated, lubricate (para 2-50a); if plungers do not slide freely in respective bores in spider, replace (para 2-50a). Replace seals (para 2-50a). | |
| | b. If plungers are adequately lubricated and are not corroded or sticking, and seals are not damaged, go to step 5 below. | |
| Step 5. | Check brake shoe linings for grease or dirt contamination. | |
| | a. If brake shoe linings are contaminated, replace brake shoes (para 2-50a). | |
| | b. If brake shoe linings are not contaminated, go to step 6 below. | |
| Step 6. | Check front axle brakes air chambers for damage. | |
| | a. If front axle brakes air chambers are damaged, replace or repair (para 2-51d(1)). | |
| | b. If front axle brakes air chambers are not damaged, go to step 7 below. | |
| Step 7. | Check air brake system lines and fittings for air leaks. | |
| | a. If lines are leaking air, repair or replace (para 2-51a). | |
| | b. If fittings are leaking air, tighten. If fitting leaks after tightening, replace (para 2-51a). | |

6. REAR AXLE BRAKES DRAGGING

- | | | |
|---------|---|--|
| Step 1. | Check wheel bearing for proper adjustment (raise wheel and use pry bar to check for any noticeable end play) or damage. Repeat for other wheel. | |
| | a. If end play is noticeable, adjust or replace wheel bearing (para 2-44b). | |
| | b. If end play is not noticeable, go to step 2 below. | |

2-46. SERVICE BRAKE SYSTEM TROUBLESHOOTING (CONT)

MALFUNCTION
TEST OR INSPECTION
CORRECTIVE ACTION

6. REAR AXLE BRAKES DRAGGING (Cont)

- Step 2. Remove rear axle brakes air chambers (para 2-51d(2)).
Remove brake drums (para 2-44b).
Remove brake shoe and lining assemblies (para 2-50b) and check brake return springs in a spring tester: spring tension shall be 75-90 pounds pull at 9-1/2 inches.
- a. If return springs do not have proper tension, replace (para 2-50b).
 - b. If return springs have proper tension, go to step 3 below.
- Step 3. Check for loose, missing, or damaged brake shoe and lining assemblies mounting hardware.
- a. If mounting hardware is loose, missing, or damaged, tighten loose parts and replace missing or damaged parts (para 2-50b).
 - b. If mounting hardware is secure and undamaged, go to step 4 below.
- Step 4. Check slack adjuster, camshaft, and associated parts for damage or wear.
- a. If parts are defective, replace (para 2-50b).
 - b. If parts are not defective, go to step 5 below.
- Step 5. Check for grease or dirt contamination on brake shoe and lining assemblies.
- a. If brake shoe and lining assemblies are contaminated, replace (para 2-50b).
 - b. If brake shoe and lining assemblies are not contaminated, go to step 6 below.
- Step 6. Check rear axle brakes air chambers for damage.
- a. If rear axle brakes air chambers are damaged, repair (para 2-51d(2)).
 - b. If rear axle brakes air chambers are not damaged, go to step 7 below.

2-46. SERVICE BRAKE SYSTEM TROUBLESHOOTING (CONT)

MALFUNCTION
TEST OR INSPECTION
CORRECTIVE ACTION

6. REAR AXLE BRAKES DRAGGING (Cont)

- Step 7. Check air brake system lines and fittings for air leaks.
- a. If lines are leaking air, repair or replace (para 2-51a).
 - b. If fittings are leaking air, tighten. If fitting leaks after tightening, replace (para 2-51a).

7. FRONT AXLE BRAKES GRABBING

- Step 1. Check air brake system lines and hoses for damage or cracks.
- a. If lines and hoses are leaking air, repair or replace (para 2-51a).
 - b. If lines and hoses are not leaking air, go to step 2 below.
- Step 2. Remove brake drums (para 2-44a).
Check brake shoe linings for grease or dirt contamination.
- a. If brake shoe linings are contaminated, replace brake shoes (para 2-50a).
 - b. If brake shoe linings are not contaminated, go to step 3 below.
- Step 3. Remove brake shoes (para 2-50a) and check brake return springs for proper tension: spring tension shall be 75-90 pounds pull at 9-1/2 inches. Check brake shoes for excessive wear.
- a. If return springs do not have proper tension, replace (para 2-50a). If brake shoes are excessively worn, replace (para 2-50a).
 - b. If return springs have proper tension and brake shoes are not excessively worn, disassemble and reassemble wedge assembly and plungers (para 2-50a).

8. REAR AXLE BRAKES GRABBING

- Step 1. Check air brake system lines and fittings for air leaks.
- a. If lines and fittings are leaking air, repair or replace (para 2-51a).
 - b. If lines and fittings are not leaking air, go to step 2 below.

2-46. SERVICE BRAKE SYSTEM TROUBLESHOOTING (CONT)

MALFUNCTION
TEST OR INSPECTION
CORRECTIVE ACTION

8. REAR AXLE BRAKES GRABBING (Cont)

- Step 2. Install release stud in rear axle brakes air chambers (para 2-51d(2)).
Remove brake drums (para 2-44b).
Check brake shoe and lining assemblies for grease or dirt contamination.
- a. If brake shoe and lining assemblies are contaminated, replace (para 2-50b).
 - b. If brake shoe and lining assemblies are okay, go to step 3.
- Step 3. Remove slack adjuster, camshaft, and associated parts (para 2-50b) and inspect for damage or wear.
- a. If parts are damaged or worn, replace (para 2-50b).
 - b. If parts are not damaged or worn, go to step 4 below.
- Step 4. Remove rear axle brakes air chambers (para 2-51d(2)).
Remove brake shoe and lining assemblies (para 2-50b) and check brake return springs for proper tension: spring tension shall be 75-90 pounds pull at 9-1/2 inches.
Check brake shoe and lining assemblies for excessive wear.
- a. If springs do not have proper tension, replace (para 2-50b).
 - b. If brake shoe and lining assemblies are excessively worn, replace (para 2-50b).

9. FRONT AXLE BRAKES LININGS WEAR UNEVENLY

- Step 1. Remove brake drums (para 2-44a).
Check if brake shoes were installed backwards.
- a. If brake shoes were installed backwards, reinstall (para 2-50a).
 - b. If brake shoes were installed properly, go to step 2 below.
- Step 2. Remove brake shoes (para 2-50a) and check brake return springs for proper tension: spring tension shall be 75-90 pounds pull at 9-1/2 inches.
- a. If springs do not have proper tension, replace (para 2-50a).
 - b. If springs have proper tension, go to step 3 below.

2-46. SERVICE BRAKE SYSTEM TROUBLESHOOTING (CONT)

MALFUNCTION
TEST OR INSPECTION
CORRECTIVE ACTION

9. FRONT AXLE BRAKES LININGS WEAR UNEVENLY (Cont)

- Step 3. Check if wedge assembly is out of front axle brake air chamber housing socket or is damaged (wedge guide missing or broken).
- a. If wedge assembly is out of front axle brake air chamber housing socket, reinstall (para 2-50a); if wedge assembly is damaged, replace (para 2-50a).
 - b. If wedge assembly is correctly installed and not damaged, go to step 4 below.
- Step 4. Check that wedge assembly engages with plunger slots.
- a. If wedge assembly does not engage plunger slots, disassemble and reassemble (para 2-50a).
 - b. If wedge assembly engages plunger slots, go to step 5 below.
- Step 5. Check that brake shoe hold down clips hold brake shoes against shoe support pads on spider.
- a. If clips do not hold brake shoes properly, replace (para 2-50a).
 - b. If clips hold brake shoes properly, go to step 6 below.
- Step 6. Check brake shoe linings for grease or dirt contamination.
- a. If brake shoe linings are contaminated, replace brake shoes (para 2-50a).
 - b. If brake shoe linings are not contaminated, refer to Malfunction 5 above.

10. REAR AXLE BRAKES LININGS WEAR UNEVENLY

- Step 1. Remove rear axle brakes air chambers (para 2-51d(2)).
Remove brake drum (para 2-44b).
Check for loose, missing, or damaged brake shoe and lining assemblies mounting hardware.
- a. If mounting hardware is loose, missing, or damaged, tighten loose parts and replace missing or damaged parts (para 2-50b).
 - b. If mounting hardware is not loose, missing, or damaged, go to step 2 below.

2-46. SERVICE BRAKE SYSTEM TROUBLESHOOTING (CONT)

MALFUNCTION
TEST OR INSPECTION
CORRECTIVE ACTION

10. REAR AXLE BRAKES LININGS WEAR UNEVENLY (Cont)

- Step 2. Remove brake shoe and lining assemblies (para 2-50b) and check brake return springs for proper tension: spring tension shall be 75-90 pounds pull at 9-1/2 inches.
- a. If return springs do not have proper tension, replace (para 2-50b).
 - b. If return springs have proper tension, go to step 3 below.
- Step 3. Check that spring pins are not damaged or broken.
- a. If spring pins are damaged or broken, replace (para 2-50b).
 - b. If spring pins are okay, refer to Malfunction 3, step 4, above.

11. FRONT AXLE BRAKES FROZEN OR LOCKED

- Step 1. Remove brake drums (para 2-44a).
Disassemble front brakes (para 2-50a) and check plungers for damage.
- a. If plungers are damaged, replace (para 2-50a).
 - b. If plungers are not damaged, go to step 2 below.
- Step 2. Check front axle brakes air chambers for damage.
- a. If front axle brakes air chambers are damaged, repair (para 2-51d(1)).

12. REAR AXLE BRAKES FROZEN OR LOCKED

- Step 1. Check air brake system lines and fittings for air leaks.
- a. If lines are leaking air, repair or replace (para 2-51a).
 - b. If fittings are leaking air, tighten. If fitting leaks after tightening, replace (para 2-51a).
 - c. If air leaks are not found, go to step 2 below.
- Step 2. Check rear axle brakes air chambers for damage.
- a. If damage is found, repair (para 2-51d(2)).
 - b. If damage is not found, go to step 3 below.

2-46. SERVICE BRAKE SYSTEM TROUBLESHOOTING (CONT)

MALFUNCTION
TEST OR INSPECTION
CORRECTIVE ACTION

12. REAR AXLE BRAKES FROZEN OR LOCKED (Cont)

- Step 3. Remove rear axle brakes air chambers (para 2-51d(2)).
Remove brake drums (para 2-44b).
Disassemble rear axle brakes (para 2-50b) and check slack adjuster, camshaft, and associated parts for damage or wear.

If parts are damaged or worn, replace (para 2-50b).

13. INSUFFICIENT BRAKE FORCE TO STOP VEHICLE (FRONT AXLE BRAKES)

- Step 1. Remove brake drums (para 2-44a).
Check brake shoe linings for excessive wear (worn to depth of groove at side of lining).

- a. If brake shoe linings are excessively worn, replace brake shoes (para 2-50a).
- b. If brake shoe linings are okay, go to step 2 below.

- Step 2. Check brake shoe linings for grease or dirt contamination.

- a. If brake shoe linings are contaminated, replace brake shoes (para 2-50a).
- b. If brake shoe linings are not contaminated, go to step 3 below.

- Step 3. Disassemble front axle brakes (para 2-50a) and check plungers for damage.

- a. If plungers are damaged, replace (para 2-50a).
- b. If plungers are not damaged, go to step 4 below.

- Step 4. Check front axle brakes air chambers for damage.

- a. If front axle brakes air chambers are damaged, repair (para 2-51d(1)).
- b. If front axle brakes air chambers are okay, go to step 5 below.

- Step 5. Check air brake system lines and fittings for air leaks.

- a. If lines or fittings are leaking air, repair or replace (para 2-51a).
- b. If lines and fittings are okay, refer to Malfunction 5 above.

2-46. SERVICE BRAKE SYSTEM TROUBLESHOOTING (CONT)

MALFUNCTION	TEST OR INSPECTION	CORRECTIVE ACTION
--------------------	---------------------------	--------------------------

14. INSUFFICIENT BRAKE FORCE TO STOP VEHICLE (REAR AXLE BRAKES)

- | | | |
|---------|--|--|
| Step 1. | Remove rear axle brakes air chambers (para 2-51d(2)). Check brake shoe and lining assemblies for excessive wear. | |
| | a. If linings are excessively worn, replace brake shoe and lining assemblies (para 2-50b). | |
| | b. If linings are not excessively worn, go to step 2 below. | |
| Step 2. | Check brake shoe and lining assemblies for grease or dirt contamination. | |
| | a. If brake shoe and lining assemblies are contaminated, replace (para 2-50b). | |
| | b. If brake shoe and lining assemblies are not contaminated, go to step 3 below. | |
| Step 3. | Check slack adjuster, camshaft, and associated parts for damage or wear. | |
| | a. If parts are damaged or worn, replace (para 2-50b). | |
| | b. If parts are not damaged or worn, go to step 4 below. | |
| Step 4. | Check rear axle brakes air chambers for damage. | |
| | a. If rear axle brakes air chambers are damaged, repair (para 2-51d(2)). | |
| | b. If rear axle brakes air chambers are not damaged, go to step 5 below. | |
| Step 5. | Check air brake system lines and fittings for air leaks. | |
| | a. If lines are leaking air, repair or replace (para 2-51a). | |
| | b. If fittings are leaking air, tighten. If fitting leaks after tightening, replace (para 2-51a). | |

15. FRONT AXLE BRAKES SQUEAK OR GROAN, OR SCRAPING NOISE WHEN APPLIED

- | | | |
|---------|---|--|
| Step 1. | Remove brake drums (para 2-44a).
Check brake shoe linings for wear (worn to depth of groove at side of lining), glaze, lubricant contamination, or excessive dust. | |
|---------|---|--|

2-46. SERVICE BRAKE SYSTEM TROUBLESHOOTING (CONT)

MALFUNCTION
TEST OR INSPECTION
CORRECTIVE ACTION

15. FRONT AXLE BRAKES SQUEAK OR GROAN, OR SCRAPING NOISE WHEN APPLIED (Cont)

WARNING

Brake linings contain asbestos fibers. Do not generate dust when working on brake system. Do not remove dust or dirt with compressed air because serious bodily harm may result from breathing asbestos dust.

- a. If brake shoe linings are worn, glazed, or contaminated, replace (para 2-50a); remove excessive dust.
- b. If brake shoe linings are not worn, glaze, or contaminated, and there is not excessive dust, go to step 2 below.

Step 2. Check brake drum for scored condition.

- a. If brake drum is scored, replace (para 2-44a).
- b. If brake drum is not scored, refer to Malfunction 5, step 2, above.

16. REAR AXLE BRAKES SQUEAK OR GROAN, OR SCRAPING NOISE WHEN APPLIED

Step 1. Remove rear axle brakes air chambers (para 2-51d(2)).
Remove brake drums (para 2-44b).
Check brake shoe linings for wear, glaze, lubricant contamination, or excessive dust.

WARNING

Brake linings contain asbestos fibers. Do not generate dust when working on brake system. Do not remove dust or dirt with compressed air because serious bodily harm may result from breathing asbestos dust.

- a. If brake linings are worn, glazed, or contaminated, replace brake shoe and lining assemblies (para 2-50b); remove excessive dust.
- b. If brake linings are not worn, glazed, or contaminated, and dust is not excessive, go to step 2 below.

Step 2. Check brake drum for scored condition.

- a. If brake drum is scored, replace (para 2-44b).
- b. If brake drum is okay, refer to Malfunction 10, step 2, above.

12-47. AIR BRAKE SYSTEM TROUBLESHOOTING

MALFUNCTION
TEST OR INSPECTION
CORRECTIVE ACTION

1. RAPID PRESSURE DROP AFTER ENGINE IS SHUT DOWN (BRAKES RELEASED)

- Step 1. With engine off and brake pedal released, record drop in AIR PRESS gage reading during 1-minute period.
- a. If AIR PRESS gage reading drops less than 2 psi per minute, air system leakage is within limits.
 - b. If AIR PRESS gage reading drops more than 2 psi per minute, go to step 2 below.
- Step 2. Check for open drain cock on service air tank.
- a. If drain cock is open, close it fully.
 - b. If drain cock is closed fully, go to step 3 below.
- Step 3. Check air brake system lines and fittings for air leaks.
- a. If line is leaking air, replace (para 2-51a). If fitting is leaking air, tighten. If fitting leaks after tightening, replace (para 2-51a).
 - b. If lines and fittings are not leaking air, notify direct support maintenance.

2. RAPID PRESSURE DROP AFTER ENGINE IS SHUT DOWN (BRAKES APPLIED)

- Step 1. With engine off and brake pedal released, record drop in AIR PRESS gage reading during 1-minute period.
- a. If AIR PRESS gage reading drops more than 2 psi per minute, go to Malfunction 1, step 2, above.
 - b. If AIR PRESS gage reading drops less than 2 psi per minute, go to step 2 below.
- Step 2. With engine off and brake pedal fully depressed, record drop in AIR PRESS gage reading during 1-minute period.
- a. If AIR PRESS gage reading drops less than 3 psi per minute, air system leakage is within limits.
 - b. If AIR PRESS gage reading drops more than 3 psi per minute. Go to step 3 below.

2-47. AIR BRAKE SYSTEM TROUBLESHOOTING (CONT)

MALFUNCTION
TEST OR INSPECTION
CORRECTIVE ACTION

2. RAPID PRESSURE DROP AFTER ENGINE IS SHUT DOWN (BRAKES APPLIED) (Cont)

Step 3. Check air brake system lines and fittings for air leaks.

- a. If line is leaking air, replace (para 2-51a). If fitting is leaking air, tighten. If fitting leaks after tightening, replace (para 2-51a).
- b. If air leaks are not seen, notify direct support maintenance.

3. PRESSURE BUILDS UP SLOWLY

Step 1. Open drain cock on service air tank to relieve system pressure to zero; then close drain cock. Note and record time; then start engine and operate at 1200 rpm. Note and record time when AIR PRESS gage indicates 90 psi.

- a. If elapsed time is 5 minutes or less, no further action required.
- b. If elapsed time is more than 5 minutes, go to step 2 below.

Step 2. Stop engine, open engine hood, and check fan and air compressor belts for proper tension. Depress belts midway between fan pulley and crankshaft pulley. Belts should deflect 1/2 inch with moderate thumb pressure.

- a. If belts do not deflect 1/2 inch, adjust tension (para 2-15d).
- b. If belts deflect approximately 1/2 inch, go to step 3 below.

Step 3. With engine off and brake pedal released, record drop in AIR PRESS gage reading during 1-minute period.

- a. If reading drops more than 2 psi per minute, refer to Malfunction 1, step 2, above.
- b. If reading drops less than 2 psi per minute, notify direct support maintenance.

4. PRESSURE WON'T BUILD UP TO NORMAL

Troubleshoot AIR PRESS gage (para 2-83).

- a. If AIR PRESS gage is defective, replace (para 2-87b).
- b. If AIR PRESS gage is okay, go to Malfunction 3, step 1, above.

2-47. AIR BRAKE SYSTEM TROUBLESHOOTING (CONT)

MALFUNCTION
TEST OR INSPECTION
CORRECTIVE ACTION

5. PARKING (SPRING) BRAKES WON'T RELEASE

- Step 1. Check AIR PRESS gage for minimum indication of 60 psi.
- a. If indication is less than 60 psi, refer to Malfunction 4 above.
 - b. If indication is at least 60 psi, go to step 2 below.
- Step 2. Check if PARKING BRAKE valve is pushed down.
- a. If PARKING BRAKE valve is up, push down.
 - b. If PARKING BRAKE valve is pushed down, go to step 3 below.
- Step 3. With AIR PRESS gage reading 60 psi minimum and PARKING BRAKE valve pushed down, check air brake system lines and fittings for air leaks.
- a. If line is leaking air, replace (para 2-51a). If fitting is leaking air, tighten. If fitting leaks after tightening, replace (para 2-51a).
 - b. If are leaks are not seen, notify direct support maintenance.

2-48. AIR COMPRESSOR TROUBLESHOOTING

MALFUNCTION
TEST OR INSPECTION
CORRECTIVE ACTION

1. PRESSURE TOO HIGH, OR AIR COMPRESSOR WON'T CUT OUT

Perform air compressor governor adjustment (para 2-52d).

- a. If governor adjusts for cut out at 118-120 psi pressure, and cut in at 100-102 psi pressure, no further action required.
- b. If governor won't adjust, notify direct support maintenance.

2. PRESSURE BUILDS UP SLOWLY

Check for clogged air strainer filter element.

- a. If filter element is clogged, clean or replace (para 2-52b).
- b. If filter element is okay, refer to para 2-47, Malfunction 3.

2-48. AIR COMPRESSOR TROUBLESHOOTING (CONT)

MALFUNCTION
TEST OR INSPECTION
CORRECTIVE ACTION

3. AIR COMPRESSOR KNOCKS

Remove cotter pin (para 2-52e) and check pulley nut for looseness.

- a. If nut is loose, tighten (para 2-52e) and install new cotter pin (para 2-52e). Grasp pulley and check for play on shaft; replace pulley (para 2-52e) if play is excessive.
- b. If nut is tight, install new cotter pin (para 2-52e). Then notify direct support maintenance.

2-49. TRAILER BRAKE LINES AND COUPLINGS TROUBLESHOOTING

MALFUNCTION
TEST OR INSPECTION
CORRECTIVE ACTION

1. TRAILER BRAKES DO NOT RELEASE

Step 1. Check if air system pressure is above 60 psi.

- a. If air system pressure is below 60 psi, run engine at 1200 rpm to increase air system pressure.
- b. If air supply is above 60 psi, go to step 2 below.

Step 2. Check if tractor protection valve is fully depressed.

- a. If tractor protection valve is not depressed, depress fully.
- b. If tractor protection valve is fully depressed, go to step 3.

Step 3. Check if trailer brake air lines are properly connected (emergency (red) hose to emergency connection on trailer; service (blue) hose to service connection on trailer). Check trailer brake lines and couplings for air leaks.

- a. If air lines are not connected properly, reconnect (para 2-53a).
- b. If lines and couplings are leaking air, repair or replace (para 2-53a).
- c. If air lines are connected properly and lines and couplings are not leaking, go to step 4 below.

2-49. TRAILER BRAKE LINES AND COUPLINGS TROUBLESHOOTING (CONT)

MALFUNCTION
TEST OR INSPECTION
CORRECTIVE ACTION

1. TRAILER BRAKES DO NOT RELEASE (Cont)

- Step 4. Remove glad hands from emergency (red) and service (blue) trailer hoses and install calibrated air pressure gage on each hose. Depress tractor protection valve. Test gage on red hose should indicate air system pressure (same as AIR PRESS gage indication). Test gage on blue hose should indicate zero psi.
- a. If test gage on red hose indicates zero psi and test gage on blue hose indicates air system pressure, hoses are crossed at tractor protection valve; reconnect (para 2-53a).
 - b. If test gage on red hose indicates air system pressure and test gage on blue hose indicates zero psi, go to Malfunction 2 below.
 - c. If both test gages indicate zero psi, notify direct support maintenance.

2. TRAILER SERVICE BRAKES DO NOT FUNCTION (CAB GUARD)

- Step 1. Remove glad hands from emergency (red) and service (blue) trailer air hoses and install calibrated air pressure gage on each hose. With the tractor air system pressure at 100 psi, depress tractor protection valve. Test gage on red hose should indicate air system pressure (same as AIR PRESS gage indication). Depress the brake treadle valve fully and watch pressure gage on blue hose. Test gage on blue hose should indicate air system pressure (same as AIR PRESS gage indication).
- a. If indication of test gage on blue hose agrees to within 10 psi of AIR PRESS gage indication, go to step 2 below.
 - b. If indication of test gage on blue hose differs by more than 10 psi from AIR PRESS gage indication, notify direct support maintenance.
- Step 2. Remove glad hands from emergency (red) and service (blue) trailer air hoses and install calibrated air pressure gage on each hose. With the tractor air system pressure at 100 psi, depress tractor protection valve. Test gage on red hose should indicate air system pressure (same as AIR PRESS gage indication). Pull trailer hand brake control all the way down. Test gage on blue hose should indicate air system pressure (same as AIR PRESS gage indication).

2-49. TRAILER BRAKE LINES AND COUPLINGS TROUBLESHOOTING (CONT)

MALFUNCTION	TEST OR INSPECTION	CORRECTIVE ACTION
--------------------	---------------------------	--------------------------

2. TRAILER SERVICE BRAKES DO NOT FUNCTION (CAB GUARD) (Cont)

- | | |
|-------------------|--|
| Step 2.
(cont) | <ul style="list-style-type: none"> a. If indication of test gage on blue hose agrees to within 10 psi of AIR PRESS gage indication, trailer brake system functions properly. b. If indication of test gage on blue hose differs by more than 10 psi from AIR PRESS gage indication, notify direct support maintenance. |
|-------------------|--|

3. TRAILER SERVICE BRAKES DO NOT FUNCTION (REAR OF TRACTOR)

- | | |
|---------|---|
| Step 1. | <p>Remove glad hands from emergency (red) and service (blue) trailer air hoses and install calibrated air pressure gage on each hose. With the tractor air system pressure at 100 psi, depress tractor protection valve. Test gage on red hose should indicate air system pressure (same as AIR PRESS gage indication). Depress the brake treadle valve fully and watch pressure gage on blue hose. Test gage on blue hose should indicate air system pressure (same as AIR PRESS gage indication).</p> <ul style="list-style-type: none"> a. If indication of test gage on blue hose agrees to within 10 psi of AIR PRESS gage indication, go to step 2 below. b. If indication of test gage on blue hose differs by more than 10 psi from AIR PRESS gage indication, notify direct support maintenance. |
| Step 2. | <p>Remove glad hands from emergency (red) and service (blue) trailer air hoses and install test air pressure gage on each hose. With the tractor air system pressure at 100 psi, depress tractor protection valve. Test gage on red hose should indicate air system pressure (same as AIR PRESS gage indication). Pull trailer hand brake control all the way down. Test gage on blue hose should indicate air system pressure (same as AIR PRESS gage indication).</p> <ul style="list-style-type: none"> a. If indication of test gage on blue hose agrees to within 10 psi of AIR PRESS gage indication, trailer brake system functions properly. b. If indication of test gage on blue hose differs by more than 10 psi from AIR PRESS gage indication, notify direct support maintenance. |

12-50. SERVICE BRAKE SYSTEM MAINTENANCE

- a. Front Axle Brakes.

This task covers:

- a. Removal/ Disassembly
- b. Cleaning
- c. Inspection
- d. Reassembly/Installation
- e. Adjustment

INITIAL SETUP:

Tools

No. 1 Common Organizational Maintenance Tool Kit

- Adjustable open end wrench
- Socket wrench set
- Torque wrench
- Screwdriver
- Safety glasses

Automotive Mechanic's Tool Kit

- Brake repair pliers
- Brake shoe adjusting tool
- Thickness gage

Materials/Parts

- Cleaning solvent Item 1, Appendix C
- Clean cloths Item 2, Appendix C
- Grease Item 16, Appendix C
- Masking tape Item 27, Appendix C
- Seals FSCM 78500 PN A1705K219

Personnel Required

Wheel Vehicle Mechanic MOS 63B

Equipment Condition

Paragraph Condition Description

- Parked on level surface, engine off, and parking brake applied.
- Rear wheels blocked.
- Front of chassis raised, with jack stands in position.
- 2-57 Front wheels and tires removed.
- 2-43b Front axle hubs and drums removed.
- 2-51d(l) Front axle brake chambers removed.

STEP	LOCATION	ITEM	ACTION	REMARKS
------	----------	------	--------	---------

REMOVAL/DISASSEMBLY

WARNING

Brake linings contain asbestos fibers. Do not generate dust when working on brake system. Do not remove dust or dirt with compressed air because serious bodily harm may result from breathing asbestos dust.

1	Front axle end, right hand side	<ul style="list-style-type: none"> a. Two return springs (1) b. Two brake shoes (2) c. Two guide screws (3) and washers (4) 	<ul style="list-style-type: none"> a. Unhook b. Remove Disengage Remove 	<ul style="list-style-type: none"> Use brake repair pliers From clips (18) and slots in ends of adjusting bolts (11) and plungers (9) From plunger housings on spider (25)
---	---------------------------------	--	---	---

2-50. SERVICE BRAKE SYSTEM MAINTENANCE (CONT)

a. Front Axle Brakes (cont).

KEY

- 1. Return springs (2)
- 2. Brake shoes (2)
- 3. Guide screws (2)
- 4. Washers (2)
- 5. Guide screws (2)
- 6. Washers (2)
- 7. Springs (2)
- 8. Pawls (2)
- 9. Plungers (2)
- 10. Seals (2)
- 11. Adjusting bolts (2)
- 12. Adjusting sleeves (2)
- 13. Plungers (2)
- 14. Seals (2)
- 15. Capscrews (2)
- 16. Lock washers (2)
- 17. Nuts (2)
- 18. Clips (2)
- 19. Wedge assemblies (2)
- 20. Locknuts (8)
- 21. Washers (8)
- 22. Capscrews (8)
- 23. Washers (8)
- 24. Plate
- 25. Spider
- 26. Capscrews (4)
- 27. Lock washers (4)
- 28. Dust shield
- 29. Plugs (4)
- 30. Plugs (2)

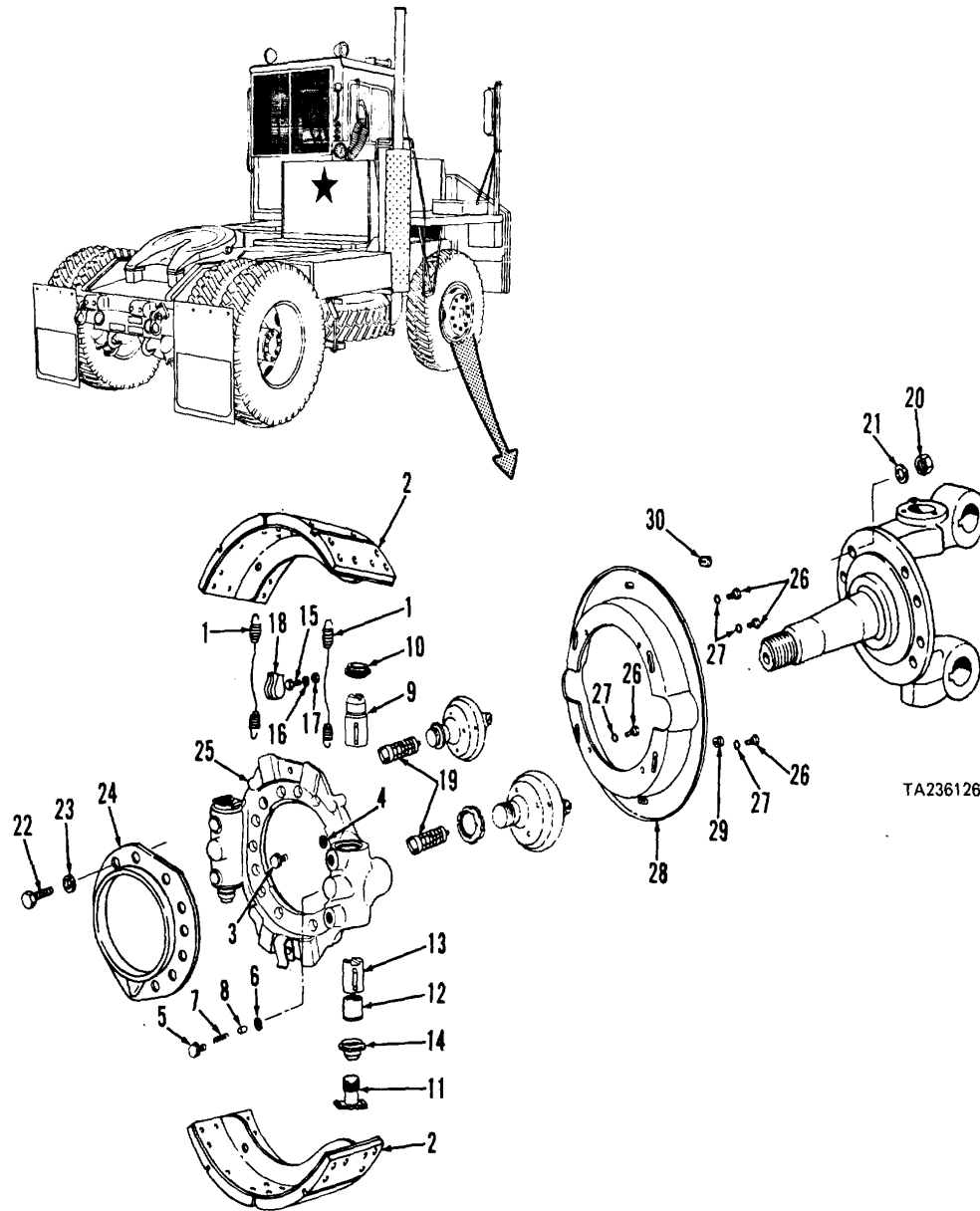

2-50. SERVICE BRAKE SYSTEM MAINTENANCE (CONT)

a. Front Axle Brakes (cont).

STEP	LOCATION	ITEM	ACTION	REMARKS
REMOVAL/DISASSEMBLY (cont)				
1 (cont)		d. Two guide screws (5), washers (6), springs (7), pawls (8), and plungers (9)	Remove	Do not interchange parts of plunger (9) assemblies. Keep mating parts together
		e. Two seals (10)	Remove and discard	
		f. Two adjusting bolts (11), adjusting sleeves (12), and plungers (13)	Remove	Do not interchange parts of plunger (13) assemblies. Keep mating parts together
		g. Two seals (14)	Remove and discard	
		h. Two capscrews (15), lock washers (16), nuts (17), and clips (18)	Remove	
		i. Two wedge assemblies (19)	Remove	
		j. Eight locknuts (20), washers (21), capscrews (22), washers (23), plate (24), and brake spider (25)	Remove	
		k. Four capscrews (26), lock washers (27), and dust shield (28)	Remove	
		l. Four plugs (29) and two plugs (30)	Remove	Pry from dust shield (28)

2-50. SERVICE BRAKE SYSTEM MAINTENANCE (CONT)

- a. Front Axle Brakes (cont).

STEP	LOCATION	ITEM	ACTION	REMARKS
------	----------	------	--------	---------

REMOVAL/DISASSEMBLY (cont)

NOTE

Repeat step 1 above to remove and disassemble left hand front brake.

CLEANING

2		a. Brake shoes (2)	Clean	Wipe with clean, dry cloth
---	--	--------------------	-------	----------------------------

WARNING

Dry cleaning solvent (P-D-680), used to clean parts is toxic and flammable. Wear protective goggles and gloves and use only in a well ventilated area. Avoid contact with skin, eyes, and clothes and don't breathe vapors. Do not use near open flame or excessive heat and don't smoke when using it. Failure to do so could cause serious injury. If you become dizzy while using cleaning solvent, get fresh air and medical attention immediately. If contact with skin or clothes is made, flush with large amounts of water. If contact with eyes is made, wash eyes with water and seek medical aid immediately.

Compressed air must not exceed 30 psi. Wear safety glasses when drying parts with compressed air. Failure to do so could cause serious injury to eyes and possible blindness. If you hurt your eyes or if a foreign object is blown into your eyes, seek medical attention immediately.

		b. All other parts	Clean	Use cleaning solvent P-D-680; dry with compressed air
--	--	--------------------	-------	---

INSPECTION

3		a. Brake shoes (2)	Inspect	Replace if cracked, distorted, if linings have absorbed grease or oil, or if linings are worn to depth of groove at side of lining
		b. Plungers (9 and 13)	Inspect	Replace if pitted, or if plungers do not slide freely in respective bores in spider (25)

2-50. SERVICE BRAKE SYSTEM MAINTENANCE (CONT)

a. Front Axle Brakes (cont).

STEP	LOCATION	ITEM	ACTION	REMARKS
INSPECTION (cont)				
3 (cont)		c. Spider (25)	Inspect	Replace if cracked, bent, or otherwise damaged
		d. Wedge assemblies (19)	Inspect	Replace if spring cracked or distorted, plunger rod or roller cage bent, or rollers loose or damaged. Replace as an assembly.
		e. All other parts	Inspect	Replace if cracked, bent, worn, or threads damaged
REASSEMBLY/INSTALLATION				
4	Front axle end, right hand side	a. Plate (24)	Position	On spider (25)
		b. Four lock washers (27) and capscrews (26)	Install and tighten	
		c. Four plugs (29) and two plugs (30)	Install	Press into slots in dust shield (28)
		d. Two clips (18)	Position	On spider (25)
		e. Two nuts (17), lock washers (16), and capscrews (15)	Install	
		f. Plate (24) and spider (25)	Position	On steering knuckle
		g. Washers (23), capscrews (22), washers (21), and locknuts (20)	Install	
		h. Two plungers (9)	Cover	With thin strip of masking tape and cover brake shoe web slots in ends to prevent damage to seals (10)
		i. Two new seals (10)	a. Lubricate	With grease, and apply film to inside surfaces of seals (10)

2-50. SERVICE BRAKE SYSTEM MAINTENANCE (CONT)

a. Front Axle Brakes (cont).

STEP	LOCATION	ITEM	ACTION	REMARKS
REASSEMBLY/INSTALLATION (cont)				
4 (cont)			b. Install	Push seals (10) onto plungers (9), stretching outer seal lip over taped end of plunger, until inner lip is seated in second plunger groove and outer lip is seated in first plunger groove. Remove masking
tape		j. Two plungers (9)	Lubricate	Coat plungers (9) and plunger housing bores with grease; fill cavities behind seals (10) with grease

NOTE

Install plungers (9) marked "L" in left hand brake, and plungers marked "R" in right hand brake. The solid plungers (9) must be installed in the plunger housing locations at the trailing end of each brake shoe (2) as shown below.

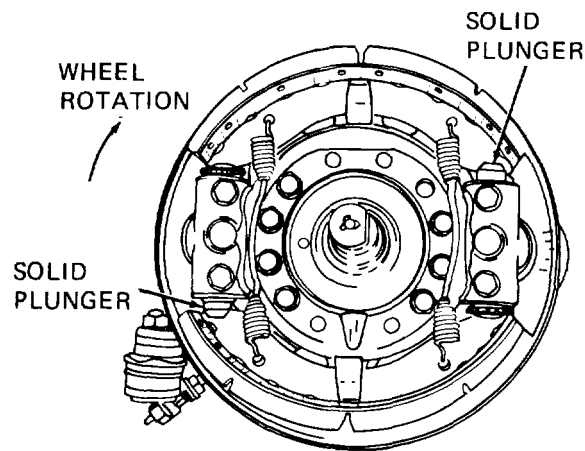

k. Two plungers (9)

Install

Into bores of spider (25), with keyways in plungers aligned with holes in guide screws (3). Be sure plungers go all the way into bores, and sit on bosses at bottom of bores

2-50. SERVICE BRAKE SYSTEM MAINTENANCE (CONT)

a. Front Axle Brakes (cont).

STEP	LOCATION	ITEM	ACTION	REMARKS
REASSEMBLY/INSTALLATION (cont)				
4 (cont)		l. Two seals (10)	Install	Use 1-3/4 inch wrench socket, and drive seals (10) on plungers (9) onto plunger housings of spider (25)
		m. Two washers (4) and guide screws (3)	Install	Into spider (25). Ends of screws must enter keyways of plungers (9)
		n. Two plungers (13)	a. Lubricate	Coat inside and outside surfaces with grease
		o. Two new seals (14) and adjusting bolts (11)	b. Install	Into bores of spider (25)
			a. Lubricate b. Assemble	With grease
		p. Two adjusting sleeves (12)	a. Lubricate b. Install	With grease On adjusting bolts (11)

NOTE

Adjusting sleeves (12) must bottom on shoulders of plungers (13). If adjusting bolts (11) are threaded too far into sleeves, capscrews will bottom in plungers, and automatic adjusters will not function.

		q. Two adjusting sleeves (12), plungers (13), seals (14), and adjusting bolts (11)	Install	Use 1-3/4 inch wrench socket, drive seals (14) onto plunger housings of spider (25)
		r. Two pawls (8)	Lubricate	With grease
		s. Two pawls (8), springs (7), washers (6), and guide screws (5)	Install	In spider (25). Keys of pawls (8) must enter keyways of plungers (13)
		t. Guide screws (3 and 5)	Tighten	To 15-25 pounds foot torque
		u. Two brake shoes (2)	Align	In clips (18), with webs of brake shoes fitting in slots of plungers (9) and adjusting bolts (11)

2-50. SERVICE BRAKE SYSTEM MAINTENANCE (CONT)

a. Front Axle Brakes (cont).

STEP	LOCATION	ITEM	ACTION	REMARKS
REASSEMBLY/INSTALLATION (cont)				
4 (cont)		v. Two return springs (1)	Install	Use brake repair pliers
		w. Two wedge assemblies (19)	a. Lubricate b. Install	With grease Into spiders (25). Check that rollers on wedge assemblies fit into slots in ends of plungers (9 and 13)
		x. Hub and drum	Install	Para 2-43b
		y. Brake chambers	Install	Para 2-51d(1)

NOTE

Repeat step 4 above to reassemble and install left hand front brake.

ADJUSTMENT

5	Dust shield (28)	a. Two plugs (30)	Remove	Pry from upper slots in dust shield (28)
---	------------------	-------------------	--------	--

NOTE

In the following step, only two plugs (29) need be removed from dust shield (28). The front brake adjusting slots are below the forward air chamber and above the rear air chamber. If the adjusting bolts (11) are not found at these locations, the brakes are assembled on the wrong side of the front axle.

		b. Two plugs (29)	Remove	
6	Upper brake shoe, right hand front brake	a. Upper inspection slot	Check	Drum-to-lining clearance
		b. Adjusting bolt (11)	Rotate	Use brake shoe adjusting tool. Rotate adjusting bolt (11) until there is strong resistance to drum rotation. Then rotate adjusting bolt (11) in opposite direction until very light drum drag is felt

2-50. SERVICE BRAKE SYSTEM MAINTENANCE (CONT)

a. Front Axle Brakes (cont).

STEP	LOCATION	ITEM	ACTION	REMARKS
ADJUSTMENT (cont)				
6 (cont)		c. Drum to lining clearance	Measure	Use feeler gage. Drum-to-lining clearance must not exceed 0.060 inch for proper operation of the automatic adjusters

NOTE

Repeat steps 5 and 6 above for adjustment of the lower brake shoe. Then repeat steps 5 and 6 twice more for adjustment of the left hand front brake upper and lower brake shoes.

7	Brake assemblies	Two plugs (29) and two plugs (30)	Install	Press into slots in dust shields (28)
8	Front axle ends	Front wheels and tires	Install	Para 2-57
9	Front axle	Jack stands and jack	Remove	
10	Rear wheels	Wheel blocks	Remove	
11	Cab	Tractor	Road test	To check for proper brake operation

2-547

2-50. SERVICE BRAKE SYSTEM MAINTENANCE (CONT)

b. Rear Axle Brakes.

This task covers:

- a. Removal/Disassembly
- b. Cleaning
- c. Inspection
- d. Repair
- e. Reassembly/Installation

INITIAL SETUP

Tools

No. 1 Common Organizational Maintenance

Tool Kit

- Hammer
- Socket wrench set
- Retaining ring pliers
- Safety glasses
- Lubricating kit

Automotive Mechanic's Tool Kit

- Brake repair pliers
- Diagonal cutting pliers
- Pliers

Arbor press

Brass rod

Materials/Parts

Cleaning

- solvent Item 1, Appendix C
- Clean cloths Item 2, Appendix C
- Grease Item 3, Appendix C
- Soft lockwire Item 5, Appendix C
- Axle lubricant Item 6, Appendix C
- Oil seal FSCM 78500 PN A1205V1556
- Block of wood

Personnel Required

Two Wheel Vehicle Mechanics MOS 63B

References

LO 9-2320-285-12
(M878A1 Lubrication Order)

Equipment Condition

Paragraph Condition Description

- Parked on level surface, engine off, and parking brake applied.
- Front wheels blocked.
- Rear of chassis raised, with jack stands in position.
- 2-57 Rear wheels and tires removed.
- 2-51a Brake air lines removed.
- 2-51d(2) Brake air chambers removed.
- 2-44a Rear axle housing drained; drain plug installed.
- 2-44b Rear axle shafts, hubs, and drums removed.

STEP	LOCATION	ITEM	ACTION	REMARKS
------	----------	------	--------	---------

REMOVAL/DISASSEMBLY

WARNING

Brake linings contain asbestos fibers. Do not generate dust when working on brake system. Do not remove dust or dirt with compressed air because serious bodily harm may result from breathing asbestos dust.

1	Rear axle end, left hand side	a. Six capscrews (29)	Remove	Support dust shield (31)
		b. Dust shield (31)	Remove	
		c. Spring (1)	Unhook and remove	Use brake repair pliers. Support lower shoe and lining assembly (9)

2-50. SERVICE BRAKE SYSTEM MAINTENANCE (CONT)

b. Rear Axle Brakes (cont).

KEY

1. Return spring
2. Spring pins (2)
3. Retaining rings (4)
4. Retainers (4)
5. Felts (4)
6. Lockwire
7. Capscrews (2)
8. Anchor pins (2)
9. Shoe and lining assemblies (2)
10. Retaining ring
11. Washers (AR)
12. Slack adjuster
13. Washer
14. Camshaft
15. Washer
16. Oil seal
17. Capscrews (4)
18. Washers (4)
19. Brake chamber bracket
20. Oil seal
21. Nuts (16)
22. Washers (32)
23. Screws (16)

24. Spider
25. Bushings (2)
26. Bushings
27. Oil seal
28. Bushings
29. Capscrews (6)
30. Dust shield
31. Dust shield
32. Plugs (2)
33. Lubrication fittings (2)
34. Bushings (2)
35. Pins
36. Rollers
37. Setscrews

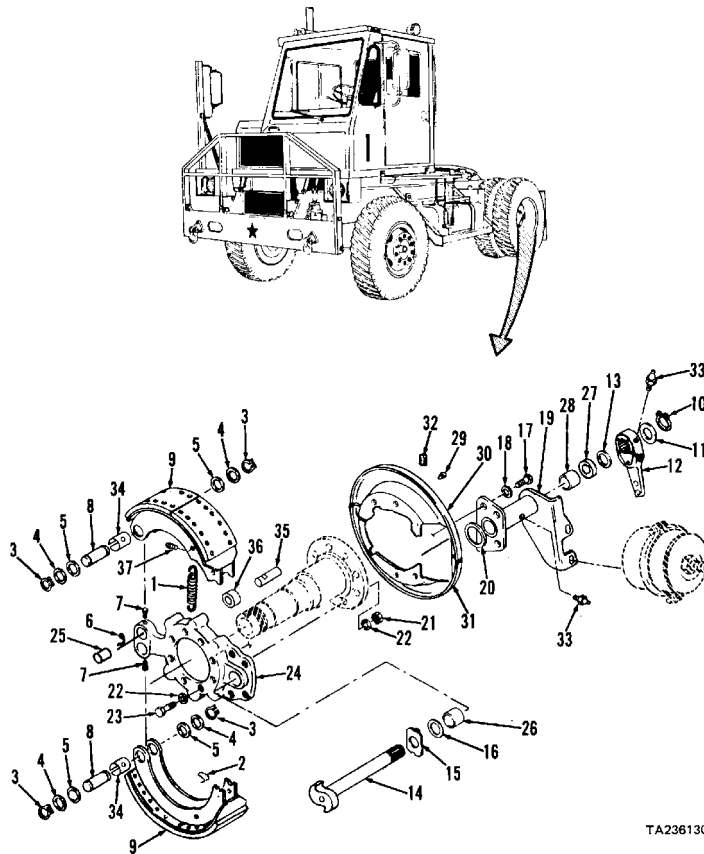

TA236130

2-50. SERVICE BRAKE SYSTEM MAINTENANCE (CONT)
--

b. Rear Axle Brakes (cont).

STEP	LOCATION	ITEM	ACTION	REMARKS
REMOVAL/DISASSEMBLY (cont)				
1 (cont)		d. Lower shoe and lining assembly (9)	Rotate	Swing down
		e. Upper shoe and lining assembly (9) and dust shield (30)	Rotate	Swing forward
		f. Dust shield (30)	Remove	
		g. Two spring pins (2)	Remove	
		h. Four retaining rings (3), retainers (4), and felts (5)	Remove	Use retaining ring pliers
		i. Lockwire (6)	Cut and remove	From heads of capscrews (7). Discard lockwire (6)
		j. Two capscrews (7)	Remove	
		k. Two anchor pins (8)	Remove	From shoe and lining assemblies (9) and spider (24)
		l. Shoe and lining assemblies (9)	Remove	
		m. Retaining ring (10), washers (11), slack adjuster (12) and washer (13)	Remove	From camshaft (14). Use retaining ring pliers

NOTE

Right and left hand camshafts (14) are not interchangeable. Tag camshaft to aid in reassembly.

n. Camshaft (14)	Remove	From spider (24) and brake chamber bracket (19)
o. Washer (15) and oil seal (16)	Remove	Discard oil seal (16)
p. Four capscrews (17)	Loosen	

2-50. SERVICE BRAKE SYSTEM MAINTENANCE (CONT)

b. Rear Axle Brakes (cont).

STEP	LOCATION	ITEM	ACTION	REMARKS
REMOVAL/DISASSEMBLY (cont)				
1 (cont)		q. 16 nuts (21), 32 washers (22), and 16 screws (23)	Remove	
		r. Spider (24)	Remove	From axle housing
		s. Four capscrews (17), washers (18), bracket (19), and oil seal (20)	Remove	
		t. Two lubrication fittings (33)	Remove	

NOTE

Repeat step 1 above to remove and disassemble righthand rear brake.

CLEANING

2		a. Shoe and lining assembly (9) brake linings	Clean	Wipe with clean, dry cloth only
---	--	---	-------	------------------------------------

WARNING

Dry cleaning solvent (P-D-680), used to clean parts is toxic and flammable. Wear protective goggles and gloves and use only in a well ventilated area. Avoid contact with skin, eyes, and clothes and don't breathe vapors. Do not use near open flame or excessive heat and don't smoke when using it. Failure to do so could cause serious injury. If you become dizzy while using cleaning solvent, get fresh air and medical attention immediately. If contact with skin or clothes is made, flush with large amounts of water. If contact with eyes is made, wash eyes with water and seek medical aid immediately.

Compressed air must not exceed 30 psi. Wear safety glasses when drying parts with compressed air. Failure to do so could cause serious injury to eyes and possible blindness. If you hurt your eyes or if a foreign object is blown into your eyes, seek medical attention immediately.

2-50. SERVICE BRAKE SYSTEM MAINTENANCE (CONT)

b. Rear Axle Brakes (cont).

STEP	LOCATION	ITEM	ACTION	REMARKS
CLEANING (cont)				
2 (cont)		b. All other parts dry with compressed air	Clean	Use cleaning solvent P-D-680;
INSPECTION				
3		a. Shoe and lining assemblies (9)	Inspect	Replace if cracked, distorted, if linings have absorbed grease or oil, or if linings are worn to 3/32 inch or less
		b. Return springs (1)	Inspect	Replace if bent, cracked, distorted, or stretched
		c. Slack adjusters (12)	Inspect	Replace if cracked, distorted, splines damaged, clevis pin holes elongated, or otherwise damaged
		d. Dust shields (30 and 31), brake chamber brackets (19) and spring pins (2)	Inspect distorted	Replace if bent, cracked, or
		e. All other parts	Inspect	Replace if cracked, bent, worn, or threads damaged

REPAIR

NOTE

Do not perform step 4 below unless inspection requires replacement of bushings (25, 26, and 28) or oil seal(27).

4	Spider (24)	a. Spider (24)	Support firmly	
		b. Bushings (25, 26, and 28) and oil seal (27)	Drive out	Insert brass rod in anchor pin hole until rod contacts bushing. Place block of wood on top of brass rod and strike wood with hammer
		c. New bushings (25, 26, and 28) and new oil seal (27)	Install	Press in using arbor press

2-50. SERVICE BRAKE SYSTEM MAINTENANCE (CONT)

b. Rear Axle Brakes (cont).

STEP	LOCATION	ITEM	ACTION	REMARKS
REPAIR (cont)				
NOTE				
Do not perform step 5 below unless inspection requires replacement of bushing (34), pin (35), or roller (36).				
5	Shoe and lining assemblies (9)	a. Bushing (34)	Remove	Press out using arbor press
		b. New bushing (34)	Install	Press in using arbor press
		c. Setscrew (37)	Remove	
		d. Pin (35) and roller (36)	Remove	Drive pin out using brass punch
		e. New roller (36)	Position	
		f. New pin (35)	Install	Drive pin in using brass punch, making sure that flat on pin aligns with hole in shoe and lining assembly (9)
		g. Setscrew (37)	Install and tighten	

REASSEMBLY/INSTALLATION

6	Rear axle end, left hand side	a. Oil seal (16)	Install	
		b. Spider (24)	Position	On axle housing
		c. New oil seal (20)	Position	On spider (24)
		d. Brake chamber bracket (19)	Position	On spider (24)
		e. Four washers (18) and cap-screws (17)	Install	
		f. 16 screws (23), 32 washers (22), and 16 nuts (21)	Install	
		g. Washer (15) and new oil seal (16)	Install	On camshaft (14)

NOTE

Right and left hand camshafts (14) are not interchangeable. Observe tag installed during disassembly and install proper camshaft (14) in following step.

2-50. SERVICE BRAKE SYSTEM MAINTENANCE (CONT)
--

b. Rear Axle Brakes (cont).

STEP	LOCATION	ITEM	ACTION	REMARKS
------	----------	------	--------	---------

REASSEMBLY/INSTALLATION (cont)

6 (cont)		h. Camshaft (14)	Insert	In spider (24), and brake chamber bracket (19). Then remove tag
		i. Washer (13) and slack adjuster (12)	Install	On camshaft (14)

NOTE

In following step select quantity and thickness of washers (11) required. Washers (11) are available in 0.032 and 0.064 inch thicknesses.

		j. Washer (11)	Install	On camshaft (14), as required to stop at retaining ring groove on camshaft
		k. Retaining ring (10)	Install	Use retaining ring pliers
		l. Two lubrication fittings (33)	Install	
		m. Shoe and lining assembly (9)	Position	On spider (24)

NOTE

Center anchor pins (8) with shoe and lining assemblies(9), with flat of anchor pin (8) facing capscrew (7)hole.

		n. Two anchor pins (8)	Install	
		o. Two capscrews (7)	Install and tighten	
		p. New lockwire (6)	Insert	Through heads of capscrews (7); then use pliers to twist
		q. Four felts (5) and retainers (4)	Install	On anchor pins (8)
		r. Four retaining rings (3)	Install	Use retaining ring pliers
		s. Upper shoe and lining assembly (9)	Rotate	Swing forward

2-50. SERVICE BRAKE SYSTEM MAINTENANCE (CONT)

b. Rear Axle Brakes (cont).

STEP	LOCATION	ITEM	ACTION	REMARKS
REASSEMBLY/INSTALLATION (cont)				
6 (cont)		t. Dust shield (30)	Position	Against upper shoe and lining assembly (9)
		u. Dust shield	Rotate	Swing into position (30) and upper shoe and lining assembly (9)
		v. Two spring pins (2)	Position	On shoe and lining assemblies (9)
		w. Return spring (1)	Install	On spring pins (2) using brake repair pliers
		x. Dust shield (31)	Position	
		y. Six capscrews (29)	Install and tighten	Secures dust shields (30 and 31)

NOTE

Repeat steps 4 thru 6 above to repair, reassemble, and install right hand rear brake.

7	Rear axle	a. Rear axle shafts, hubs, and drums	Install	Para 2-44b
		b. Axle lubricant	Install	Pars 2-44a
		c. Lubrication fittings (33)	Grease	Refer to current lubrication order
		d. Rear wheels and tires	Install	Para 2-57
		e. Brake air chambers	Install	Para 2-51d(2)
	g. Brake air	f. Brake air lines Adjust chambers	Install Para 2-51d(2)	Para 2-51a
8	Rear axle	Jack stands and jack	Remove	
9	Front wheels	Wheel blocks	Remove	
10	Cab	Tractor	Road test	Check for proper brake operation

2-51. AIR BRAKE SYSTEM MAINTENANCE

a. Air Brake Lines and Fittings.

This task covers:

- a. Removal
- b. Cleaning
- c. Inspection
- d. Repair
- e. Installation

INITIAL SETUP

Tools

No. 1 Common Organizational Maintenance

Tool Kit

Socket wrench set

Combination wrench set

Fine tooth hacksaw

Scratch wire brush

Knife

Safety glasses

Automotive Mechanic's Tool Kit

Pliers

Rule

Materials/Parts

Cleaning

Solvent

Clean cloths

Item 1, Appendix C

Item 2, Appendix C

Tags

Teflon tape

Tie straps

Item 14, Appendix C

Item 43, Appendix C

FSCM 96906 PN MS3667-2-9

Personnel Required

Two Wheel Vehicle Mechanics MOS 63B

Equipment Condition

Paragraph Condition Description

Vehicle parked on level surface, engine off, and parking brake applied.

Cab tilted 45 degrees.

2-41h(l)

All air pressure relieved.

2-65d

Heat shield removed.

STEP	LOCATION	ITEM	ACTION	REMARKS
------	----------	------	--------	---------

REMOVAL

NOTE

Tag all hoses and tubing before removal. Cut, remove, and discard all tie straps and remove all clamps as they are encountered. Note location of tie straps, and position of tees and elbows, to aid installation.

1 Cab floor, underside (1 and 2)	a. Two plugs	Remove	From treadle valve
b. Connector (3)		Loosen nut	
c. Tubing (4) with nut		Disconnect	From connector (3)
d. Connector (3)		Remove	From treadle valve
e. Elbow (5)	Loosen nut		
f. Tubing (6) with nut		Disconnect	From elbow (5)
g. Elbow (5)	Remove	From treadle valve	

2-51. AIR BRAKE SYSTEM MAINTENANCE (CONT)

a. Air Brake Lines and Fittings (cont).

STEP	LOCATION	ITEM	ACTION	REMARKS
REMOVAL (cont)				
2	Left hand frame rail, outside	a. Swivel (69) with hose (8)	Disconnect	From elbow (71)
		b. Elbow (71)	Remove	From bulkhead fitting (70)
		c. Swivel (53) with hose (51)	Disconnect	From connector (95)
		d. Connector (95) and elbow (55)	Remove	
		e. Swivel (63)	Disconnect with hose (12)	From connector (96)
3	Cab deck bulkhead	. Connector (96), elbow (65), and bushing (97)	Remove	
		a. Connector (10)	Loosen nut	
		b. Tubing (4) with nuts	a. Disconnect	From connector (10)
		c. Connector (10)	b. Remove	From cab deck
		d. Connector (11) with hose (12)	Remove	From bulkhead fitting (16)
		e. Elbow (14)	a. Disconnect	From bulkhead fitting (13)
		f. Tubing (15) with nut	b. Remove	From tractor
		g. Elbow (14)	Loosen nut	
		h. Bulkhead fitting (13)	Disconnect	From elbow (14)
		i. Elbow (17)	Remove	From bulkhead fitting (13)
		j. Tubing (18) with nut	Remove	Remove nut and pull fitting from cab deck bulkhead
		k. Elbow (17) fitting (16)	Loosen nut	
4	Air control valve	1. Bulkhead from cab deck bulkhead	Disconnect	From elbow (17)
		a. Plug (2)	Remove	From bulkhead fitting (16)
		b. Low air pressure switch	Remove	Remove nut and pull fitting
		c. Elbow (20)		
		d. Tubing (18) with nuts		
4	Air control valve	e. Elbow (20)	Remove	
		a. Plug (2)	Remove	From tee (19); para 2-51c
		b. Low air pressure switch		
		c. Elbow (20)	Loosen nut	
		d. Tubing (18) with nuts	a. Disconnect	From elbow (20)
e. Elbow (20)	b. Remove	From tractor		

2-51. AIR BRAKE SYSTEM MAINTENANCE (CONT)

a. Air Brake Lines and Fittings (cont).

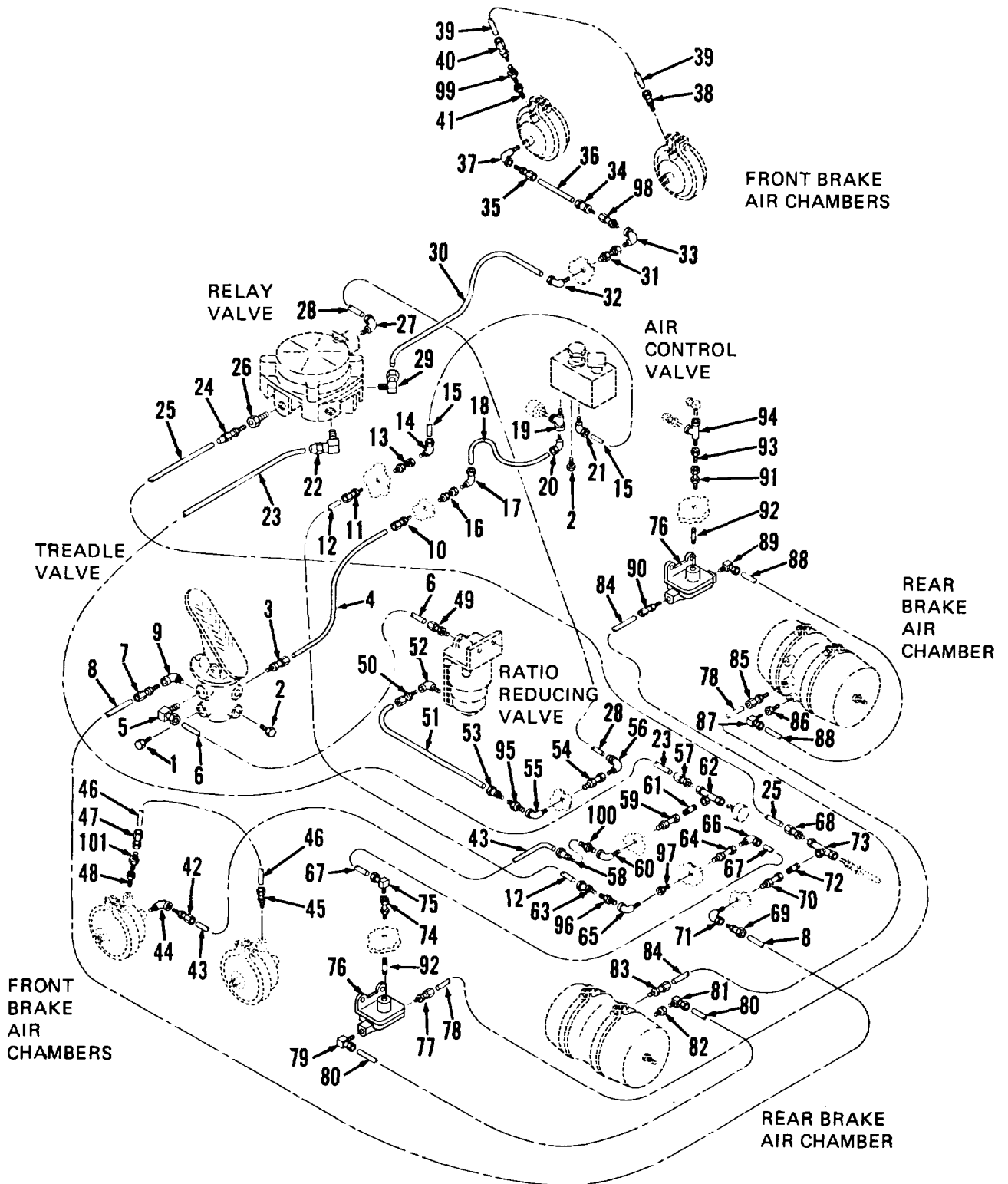

2-51. AIR BRAKE SYSTEM MAINTENANCE (CONT)

a. Air Brake Lines and Fittings (cont).

KEY

- | | | |
|----------------------|----------------------|------------------------------|
| 1. Plug | 35. Connector | 69. Swivel |
| 2. Plugs (2) | 36. Hose (BLK) | 70. Bulkhead fitting |
| 3. Connector | 37. Elbow | 71. Elbow |
| 4. Tubing (BLK) | 38. Connector | 72. Nipple |
| 5. Elbow | 39. Hose (BLK) | 73. Tee |
| 6. Tubing (BLU) | 40. Swivel | 74. Bulkhead fitting |
| 7. Fitting | 41. Bushing | 75. Elbow |
| 8. Hose (BLK) | 42. Connector | 76. Quick release valves (2) |
| 9. Elbow | 43. Hose (BLK) | 77. Connector |
| 10. Connector | 44. Elbow | 78. Tubing (ORG) |
| 11. Connector | 45. Connector | 79. Elbow |
| 12. Hose (BLK) | 46. Hose (BLK) | 80. Tubing (ORG) |
| 13. Bulkhead fitting | 47. Swivel | 81. Elbow |
| 14. Elbow | 48. Bushing | 82. Bushing |
| 15. Tubing (ORG) | 49. Connector | 83. Connector |
| 16. Bulkhead fitting | 50. Connector | 84. Tubing (BLU) |
| 17. Elbow | 51. Hose (BLK) | 85. Connector |
| 18. Tubing (BLK) | 52. Elbow | 86. Bushing |
| 19. Tee | 53. Swivel | 87. Elbow |
| 20. Elbow | 54. Bulkhead fitting | 88. Tubing (BLU) |
| 21. Elbow | 55. Elbow | 89. Elbow |
| 22. Elbow | 56. Elbow | 90. Connector |
| 23. Tubing (BLU) | 57. Connector | 91. Bulkhead fitting |
| 24. Connector | 58. Swivel | 92. Nipples (2) |
| 25. Tubing (BLK) | 59. Bulkhead fitting | 93. Bushing |
| 26. Bushing | 60. Elbow | 94. Tee |
| 27. Elbow | 61. Nipple | 95. Connector |
| 28. Tubing (BLU) | 62. Tee | 96. Connector |
| 29. Elbow | 63. Swivel | 97. Bushing |
| 30. Tubing (BLU) | 64. Bulkhead fitting | 98. Connector |
| 31. Bulkhead fitting | 65. Elbow | 99. Connector |
| 32. Elbow | 66. Elbow | 100. Connector |
| 33. Elbow | 67. Tubing (ORG) | 101. Connector |
| 34. Swivel | 68. Connector | |

STEP	LOCATION	ITEM	ACTION	REMARKS
------	----------	------	--------	---------

REMOVAL (cont)

4 (cont)		f. Tee (19) g. Elbow (21) h. Tubing (15) with nuts i. Elbow (21)	Remove Loosen nut a. Disconnect b. Remove Remove	From elbow (21) From tractor
-------------	--	--	--	---------------------------------

2-51. AIR BRAKE SYSTEM MAINTENANCE (CONT)
--

a. Air Brake Lines and Fittings (cont).

STEP	LOCATION	ITEM	ACTION	REMARKS
REMOVAL (cont)				
5	Ratio reducing valve	a. Connector (49)	Loosen nut	
		b. Tubing (6) with nuts	a. Disconnect	From connector (49)
		c. Connector (49)	b. Remove	From tractor
		d. Connector (50) with hose (51)	Remove	
6	Brake treadle valve	d. Connector (50) with hose (51)	a. Disconnect	From elbow (52)
		e. Elbow (52)	b. Remove	From tractor
6	Brake treadle valve	a. Fitting (7) with hose (8)	Remove	
		b. Elbow (9)	a. Disconnect	From elbow (9)
7	Relay valve, front crossmember	b. Remove	b. Remove	From tractor
		a. Elbow (22)	Loosen nut	
		b. Tubing (23) with nut	Disconnect	From elbow (22)
		c. Elbow (22)	Remove	
		d. Connector (24)	Loosen nut	
		e. Tubing (25) with nut	Disconnect	From connector (24)
		f. Connector (24) and bushing (26)	Remove	From relay valve
		g. Elbow (27)	Loosen nut	
		h. Tubing (28) with nut	Disconnect	From elbow (27)
		i. Elbow (27)	Remove	From relay valve
		j. Elbow (29)	Loosen nut	
8	Right hand frame rail	k. Tubing (30) with nut	Disconnect	From elbow (29)
		l. Elbow (29)	Remove	From relay valve
		a. Swivel (34) with hose (36)	Disconnect	From elbow (33)
		b. Elbow (32)	Loosen nut	
		c. Tubing (30) with nuts	a. Disconnect	From elbow (32)
		d. Elbow (32)	b. Remove	From tractor
8	Right hand frame rail	e. Connector (98) and elbow (33)	Remove	
		f. Bulkhead fitting (31)	Remove	Remove nut and pull fitting from frame rail

2-51. AIR BRAKE SYSTEM MAINTENANCE (CONT)

a. Air Brake Lines and Fittings (cont).

STEP	LOCATION	ITEM	ACTION	REMARKS
REMOVAL (cont)				
9	Front axle brakes air chambers, right hand side	a. Connector (35) with hose (36)	a. Disconnect b. Remove	From elbow (37) From tractor
		b. Elbow (37)	Remove	From front axle brake air chamber
		c. Swivel (40) with hose (39)	Disconnect	From connector (99)
		d. Connector (38) with hose (39)	a. Disconnect b. Remove	From brake air chamber From tractor
		e. Connector (99) and bushing (41)	Remove	
10	Left hand frame rail, outside	a. Swivel (58) with hose (43)	Disconnect	From connector (100)
		b. Connector (100) and elbow (60)	Remove	
11	Front axle brake air chambers, left hand side	a. Connector (42) with hose (43)	a. Disconnect b. Remove	From elbow (44) From tractor
		b. Elbow (44)	Remove	
		c. Swivel (47) with hose (46)	Disconnect	From connector (101)
		d. Connector (45) with hose	a. Disconnect b. Remove (46)	From brake air chamber From tractor
		e. Connector (101) and bushing (48)	Remove	
12	Left hand frame rail	a. Elbow (56)	Loosen nut	
		b. Tubing (28) with nuts	a. Disconnect b. Remove	From elbow (56) From tractor
		c. Elbow (56)	Remove	
		d. Bulkhead fitting (54)	Remove	Remove nut and pull fitting
		e. Connector (57)	Remove from frame rail Loosen nut	

2-51. AIR BRAKE SYSTEM MAINTENANCE (CONT)

a. Air Brake Lines and Fittings (cont).

STEP	LOCATION	ITEM	ACTION	REMARKS
REMOVAL (cont)				
12	f. Tubing (23) (cont)	a. Disconnect with nuts	From connector (57)	
		g. Connector (57)	b. Remove	From tractor
		h. Service brakes stop light switch	Remove	
		i. Tee (62) and nipple (61)	Remove	From tee (62); para 2-32f(1)
		j. Bulkhead fitting (59)	Remove	Remove nut and pull fitting from frame rail
		k. Elbow (66)	Loosen nut	
		l. Tubing (67) with nut	Disconnect	From elbow (66)
		m. Elbow (66)	Remove	
		n. Bulkhead fitting (64)	Remove	Remove nut and pull fitting from frame rail
		o. Connector (68)	Loosen nut	
		p. Tubing (25) with nuts	a. Disconnect	From connector (68)
			b. Remove	From tractor
	q. Connector (68)	Remove		
	r. Service reser- voir black tubing and connector	Remove	From tee (73); para 2-51b	
	s. Tee (73) and nipple (72)	Remove		
		t. Bulkhead fitting (70)	Remove	Remove nut and pull fitting from frame rail
13	Rear frame, above left rear axle brake air chamber	a. Elbow (75)	Loosen nut	
		b. Tubing (67) with nuts	a. Disconnect	From elbow (75)
		c. Elbow (75)	b. Remove	From tractor
		d. Connector (77)	Remove	
		e. Tubing (78) with nut	Loosen nut	
		f. Connector (77)	Disconnect	From connector (77)
		g. Elbow (79)	Remove	
		h. Tubing (80) with nut	Loosen nut	
		i. Elbow (79)	Disconnect	From elbow (79)
		j. Quick release valve (76)	Remove	
		k. Nipple (92)	Remove	From nipple (92); note position for installation
		l. Bulkhead fitting (74)	Remove	Remove nut and pull fitting from tractor frame

2-51. AIR BRAKE SYSTEM MAINTENANCE (CONT)
--

a. Air Brake Lines and Fittings (cont).

STEP	LOCATION	ITEM	ACTION	REMARKS
REMOVAL (cont)				
14	Left rear axle brake air chamber	a. Elbow (81)	Loosen nut	From elbow (81) From tractor
		b. Tubing (80) with nuts	a. Disconnect b. Remove Remove	
		c. Elbow (81) and bushing (82)	Loosen nut Disconnect Remove	From connector (83)
		d. Connector (83)		
		e. Tubing (84) with nut		
		f. Connector (83)		
15	Right rear axle brake air chamber	a. Connector (85)	Loosen nut	From connector (85) From tractor
		b. Tubing (78) with nuts	a. Disconnect b. Remove Remove	
		c. Connector (85)	Loosen nut Disconnect Remove	From elbow (87)
		d. Elbow (87)		
		e. Tubing (88) with nut		
		f. Elbow (87) and bushing (86)		
16	Rear frame, above right rear axle brake air chamber	a. Elbow (89)	Loosen nut	From elbow (89) From tractor
		b. Tubing (88) with nuts	a. Disconnect b. Remove Remove	
		c. Elbow (89)	Loosen nut Disconnect Remove Remove	From connector (90) From tractor
		d. Connector (90)		
		e. Tubing (84) with nuts		
		f. Connector (90)		
		g. Shift lockout blue tubing and connector	Remove	From tee (94); para 2-41h(1)
		h. Tractor protection valve-blue tubing and connector	Remove	From tee (94); para 2-53a
		i. Quick release valve (76)	Remove	From nipple (92); note position for installation
		j. Nipple (92)	Remove	
		k. Tee (94) and bushing (93)	Remove	
l. Bulkhead fitting (91)	Remove	Remove nut and pull fitting from tractor frame		

2-51. AIR BRAKE SYSTEM MAINTENANCE (CONT)

a. Air Brake Lines and Fittings (cont).

STEP	LOCATION	ITEM	ACTION	REMARKS
CLEANING				
17		a. Hoses and tubing	Clean	Wipe with a clean cloth moistened with water
WARNING				
<p>Dry cleaning solvent (P-D-680), used to clean parts is toxic and flammable. Wear protective goggles and gloves and use only in a well ventilated area. Avoid contact with skin, eyes, and clothes and don't breathe vapors. Do not use near open flame or excessive heat and don't smoke when using it. Failure to do so could cause serious injury. If you become dizzy while using cleaning solvent, get fresh air and medical attention immediately. If contact with skin or clothes is made, flush with large amounts of water. If contact with eyes is made, wash eyes with water and seek medical aid immediately.</p> <p>Compressed air must not exceed 30 psi. Wear safety glasses when drying parts with compressed air. Failure to do so could cause serious injury to eyes and possible blindness. If you hurt your eyes or if a foreign object is blown into your eyes, seek medical attention immediately.</p>				
		b. All other parts	Clean	Use cleaning solvent P-D-680; dry with compressed air

INSPECTION

18		a. Hoses and tubing	Inspect	Replace if cracked, split, chafed, or deteriorated. Refer to step 19 below for tubing replacement; refer to step 20 below for hose replacement
		b. All other parts	Inspect	Replace if cracked, worn, distorted, or threads damaged. Refer to step 19 below for tubing connector replacement; refer to step 20 below for hose connector replacement

2-51. AIR BRAKE SYSTEM MAINTENANCE (CONT)

a. Air Brake Lines and Fittings (cont).

STEP	LOCATION	ITEM	ACTION	REMARKS
REPAIR				
19	Tubing	a. Tubing b. Nut c. Insert d. Sleeve	Cut Remove Remove, if necessary Discard	Between nut and sleeve Slide from tubing Pull from tubing only if separated from fitting

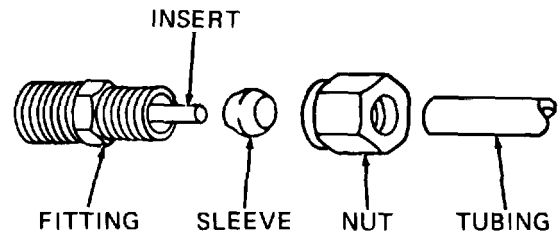

TA236242

NOTE

Repeat steps 19a thru 19d above to disassemble remaining fittings from tubing.

e. Tubing	Cut to proper length	Use new tubing; use old tubing to determine proper length
f. Nut	Position	Slide onto tubing, threaded end out
g. New sleeve h. Insert	Position Install, if necessary	Slide onto tubing Push into tubing only if separated from fitting

WARNING

Tubing must be installed over insert for secure connection. Installation of fitting without insert will allow air pressure to force tubing from fitting, resulting in dangerous loss of air pressure.

i. Tubing	Install	Push onto insert until seated inside fitting
j. Nut	Tighten	Hand tight only; prevents loss of sleeve before installation

2-51. AIR BRAKE SYSTEM MAINTENANCE (CONT)

a. Air Brake Lines and Fittings (cont).

STEP	LOCATION	ITEM	ACTION	REMARKS
------	----------	------	--------	---------

REPAIR (cont)

NOTE

Repeat steps 19e thru 19j above to install remaining fittings on tubing.

20	Hoses	a. Connector b. Nut	Turn counterclockwise out of nut and hose Turn clockwise and remove from hose	
----	-------	------------------------	--	--

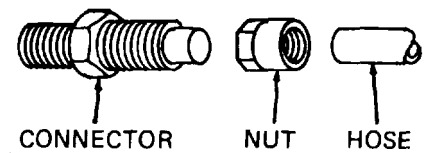

TA236184

NOTE

Repeat steps 20a and 20b above to disassemble remaining connectors from hoses.

WARNING

Dry cleaning solvent (P-D-680), used to clean parts is toxic and flammable. Wear protective goggles and gloves and use only in a well ventilated area. Avoid contact with skin, eyes, and clothes and don't breathe vapors. Do not use near open flame or excessive heat and don't smoke when using it. Failure to do so could cause serious injury. If you become dizzy while using cleaning solvent, get fresh air and medical attention immediately. If contact with skin or clothes is made, flush with large amounts of water. If contact with eyes is made, wash eyes with water and seek medical aid immediately.

	c. Connector and nut	Clean	Use cleaning solvent P-D-680; allow to air dry. Use wire brush to remove all hose residue from connector and nut
	d. Hose length	Cut to proper	Use new hose; use old hose to determine proper length required. Cut hose square using fine tooth hacksaw onto hose until hose bottoms
	e. Nut	Screw counterclockwise	and hose and tighten securely
	f. Connector	Screw clockwise into nut	

2-51. AIR BRAKE SYSTEM MAINTENANCE (CONT) J

- a. Air Brake Lines and Fittings (cont).

STEP	LOCATION	ITEM	ACTION	REMARKS
------	----------	------	--------	---------

REPAIR (cont)

NOTE

Repeat steps 20e and 20f above to install remaining connectors on hoses.

INSTALLATION

NOTE

In the following steps, wrap male pipe threads with Teflon tape before installation. Tighten tees and elbows to positions noted during removal. Secure hoses and tubing with clamps and new tie straps at locations noted during removal.

21	Rear frame, above right rear axle brake air chamber	a. Bulkhead fitting (91), bushing (93), and tee (94)	Install	
		b. Nipple (92) and quick release valve (76)	Install	
		c. Shift lockout connector and blue tubing	Install	In tee (94), para 2-41h(1)
		d. Tractor protection valve elbow and blue tubing	Install	In tee (94), para 2-53a
		e. Connector (90)	Install	
		f. Tubing (84) with nuts	a. Route b. Connect c. Tighten nut	To connector (90)
		g. Elbow (89)	Install	
		h. Tubing (88) with nuts	a. Route b. Connect c. Tighten nut	To elbow (89)
22	Right rear axle brake air chamber	a. Bushing (86)	Install	In air chamber service port
		b. Elbow (87)	Install	
		c. Tubing (88) with nut	a. Connect b. Tighten nut	To elbow (87)

2-51. AIR BRAKE SYSTEM MAINTENANCE (CONT)
--

a. Air Brake Lines and Fittings (cont).

STEP	LOCATION	ITEM	ACTION	REMARKS
INSTALLATION (cont)				
22 (cont)		d. Connector (85) e. Tubing (78) with nuts	Install a. Route b. Connect c. Tighten nut	In air chamber emergency port To connector (85)
23	Left rear axle brake air chamber	a. Connector (83) b. Tubing (84) with nut c. Bushing (82) d. Elbow (81) e. Tubing (80) with nuts	Install a. Connect b. Tighten nut Install a. Route b. Connect c. Tighten nut Install	In air chamber emergency port To connector (83) In air chamber service port To elbow (81)
24	Rear frame, above left rear axle brake air chamber	a. Bulkhead fitting (74) and elbow (75) b. Nipple (92) and quick release valve (76) c. Tubing (67) with nuts d. Elbow (79) e. Tubing (80) with nut f. Connector (77) g. Tubing (78) with nut	Install a. Route b. Connect c. Tighten nut Install a. Connect b. Tighten nut Install a. Connect b. Tighten nut Install	To elbow (75) To elbow (79) To connector (77)
25	Left hand frame rail, inside	a. Bulkhead fitting (70) and nipple (72) b. Tee (73) c. Service reservoir connector and black tubing d. Connector (68) e. Tubing (25) with nuts	Install Connect Install a. Route b. Connect c. Tighten nut	To tee (73), para 2-51b To connector (68)

2-51. AIR BRAKE SYSTEM MAINTENANCE (CONT)
--

a. Air Brake Lines and Fittings (cont).

STEP	LOCATION	ITEM	ACTION	REMARKS		
INSTALLATION (cont)						
25 (cont)		f. Bulkhead fitting (64) and elbow (66)	Install			
		g. Tubing (67) with nut	a. Connect b. Tighten nut	To elbow (66)		
		h. Tee (62), nipple (61), and bulkhead fitting (59)	Install			
		i. Connector (57)	Install			
		j. Tubing (23) with nuts	a. Route b. Connect c. Tighten nut	To connector (57)		
		k. Service brakes stop light switch	Install	In tee (62); para 2-32f(1)		
		l. Bulkhead fitting (54) and elbow (56)	Install			
		m. Tubing (28) with nuts	a. Route b. Connect c. Tighten nut	To elbow (56)		
		26	Ratio reducing valve	a. Elbow (52)	Install	
				b. Connector (50) with hose (51)	Connect	To elbow (52)
c. Hose (51)	Route					
d. Connector (49)	Install					
e. Tubing (6) with nuts	a. Route b. Connect c. Tighten nut			To connector (49)		
27	Front axle brake air chambers, left hand side	a. Bushing (48)	Install			
		b. Connector (101)	Install			
		c. Connector (45) with hose (46)	Connect	To brake air chamber		
		d. Hose (46)	Route			
		e. Swivel (47) with hose (46)	Connect	To connector (101)		
		f. Elbow (44)	Install			

2-51. AIR BRAKE SYSTEM MAINTENANCE (CONT)

a. Air Brake Lines and Fittings (cont).

STEP	LOCATION	ITEM	ACTION	REMARKS
INSTALLATION (cont)				
		g. Connector (42) with hose (43)	Connect	To elbow (44)
		h. Hose (43)	Route	
28	Front axle brake air chambers, right hand side	a. Bushing (41) b. Connector (99) c. Connector (38) with hose (39) d. Hose (39) e. Swivel (40) with hose (39) f. Elbow (37) g. Connector (35) with hose (36) h. Hose (36)	Install Install Connect Route Connect Install Connect	 To brake air chamber To connector (99) To elbow (37)
29	Frame, right hand side	a. Bulkhead fitting (31) and elbow (33) b. Connector (98) c. Swivel (34) with hose (36) d. Elbow (32) e. Tubing (30) with nuts	Install Install Connect Install a. Route b. Connect c. Tighten nut	 To connector (98) To elbow (32)
30	Relay valve	a. Elbow (29) b. Tubing (30) with nut c. Elbow (27) d. Tubing (28) with nut e. Bushing (26) f. Connector (24) g. Tubing (25) with nut h. Elbow (22) i. Tubing (23) with nut	Install a. Connect b. Tighten nut Install a. Connect b. Tighten nut Install a. Connect b. Tighten nut Install a. Connect b. Tighten nut	 To elbow (29) To elbow (27) To connector (24) To elbow (22)

2-51. AIR BRAKE SYSTEM MAINTENANCE (CONT)

a. Air Brake Lines and Fittings (cont).

STEP	LOCATION	ITEM	ACTION	REMARKS
INSTALLATION (cont)				
31	Air control valve	a. Elbow (21)	Install	
		b. Tubing (15) with nuts	a. Route b. Connect c. Tighten nut	To elbow (21)
		c. Tee (19)	Install	
		d. Elbow (20)	Install	
		e. Tubing (18) with nuts	a. Route b. Connect c. Tighten nut	To elbow (20)
		f. Plug (2)	Install and tighten	
		g. Low air pressure switch	Install	In tee (19); para 2-51c
32	Cab deck bulkhead	a. Bulkhead fitting (16)	Install	
		b. Elbow (17)	Install	
		c. Tubing (18) with nut	a. Connect b. Tighten nut	To elbow (17)
		d. Bulkhead fitting (13)	Install	
		e. Elbow (14)	Install	
		f. Tubing (15) with nut	a. Connect b. Tighten nut	To elbow (14)
		g. Connector (11) with hose (12)	Connect	To bulkhead fitting (13)
		h. Hose (12)	Route	
		i. Connector (10)	Install	
		j. Tubing (4) with nuts	a. Route b. Connect c. Tighten nut	To connector (10)
33	Brake treadle valve	a. Elbow (9)	Install	
		b. Fitting (7) with hose (8)	Connect	To elbow (9)
		c. Hose (8)	Route	
		d. Elbow (5)	Install	
		e. Tubing (6) with nut	a. Connect b. Tighten nut	To elbow (5)
		f. Connector (3)	Install	
		g. Tubing (4) with nut	a. Connect b. Tighten nut	To connector (3)
		h. Two plugs (1 and 2)	Install and tighten	

2-51. AIR BRAKE SYSTEM MAINTENANCE (CONT)

a. Air Brake Lines and Fittings (cont).

STEP	LOCATION	ITEM	ACTION	REMARKS
INSTALLATION (cont)				
34	Left hand frame rail	a. Elbow (55) and connector (95)	Install	
		b. Swivel (53) with hose (51)	Connect	To connector (95)
		c. Elbow (60) and connector (100)	Install	
		d. Swivel (58) with hose (43)	Connect	To connector (100)
		e. Bushing (97), elbow (65), and connector (96)	Install	
		f. Swivel (63) with hose (12)	Connect	To connector (96)
		g. Elbow (71)	Install	
		h. Swivel (69) with hose (8)	Connect	To elbow (71)
		i. Heat shield	Install	
35	Cab tilt pump	Cab	Lower	Para 2-65d To normal operating position
36	Tractor	Air pressure	Restore	Para 2-41h(l)
37	Lines and fittings	All connections leaks	Inspect for	Apply soapy solution around connections and check for leaks; tighten or replace leaky connections

2-51. AIR BRAKE SYSTEM MAINTENANCE (CONT)

b. Air Reservoirs.

This task covers:

- a. Removal
- b. Cleaning
- c. Inspection

- d. Repair
- e. Installation

INITIAL SETUP

Tools

No. 1 Common Organizational Maintenance

Tool Kit

- Socket wrench set
- Combination wrench set
- Fine tooth hacksaw
- Machinist's vise
- Knife
- Safety glasses

Automotive Mechanic's Tool Kit

- Pliers
- Rule

Mandrel assembly tool

FSCM 00624 PN 1582-8

Transmission jack

Materials/Parts

Cleaning

- Solvent Item 1, Appendix C
- Clean cloths Item 2, Appendix C

Tags

Hydraulic oil

Teflon tape

Tie straps

Item 14, Appendix C

Item 22, Appendix C

Item 43, Appendix C

FSCM 96906 PN MS3667-2-9

Personnel Required

Two Wheel Vehicle Mechanics MOS 63B

Equipment Condition

Paragraph

Condition Description

Vehicle parked on level surface, engine off, and parking brake applied. Cab tilted 45 degrees.

2-41h(1)

All air pressure relieved.

2-65d

Heat shield removed.

STEP	LOCATION	ITEM	ACTION	REMARKS
------	----------	------	--------	---------

REMOVAL

1	Engine, right side, air compressor	a. Elbow (1)	Loosen nut	
		b. Tubing (2) with nut	Disconnect	From elbow (1)
		c. Elbow (1)	Remove	From air compressor governor
		d. Hose assembly (3)	Disconnect	From air compressor manifold
		e. Five tie straps (4)	Cut, remove, and discard	Only if necessary to remove hose assembly (3); note locations for installation
2	Supply reservoir (41)	a. Fitting (5) with hose (6)	Disconnect	From swivel (11)
		b. Fitting (7) with hose (6)	Disconnect	From coupling (8)
		c. Hose (6) with fittings (5 and 7)	Remove	As an assembly

2-51. AIR BRAKE SYSTEM MAINTENANCE (CONT)

b. Air Reservoirs (cont).

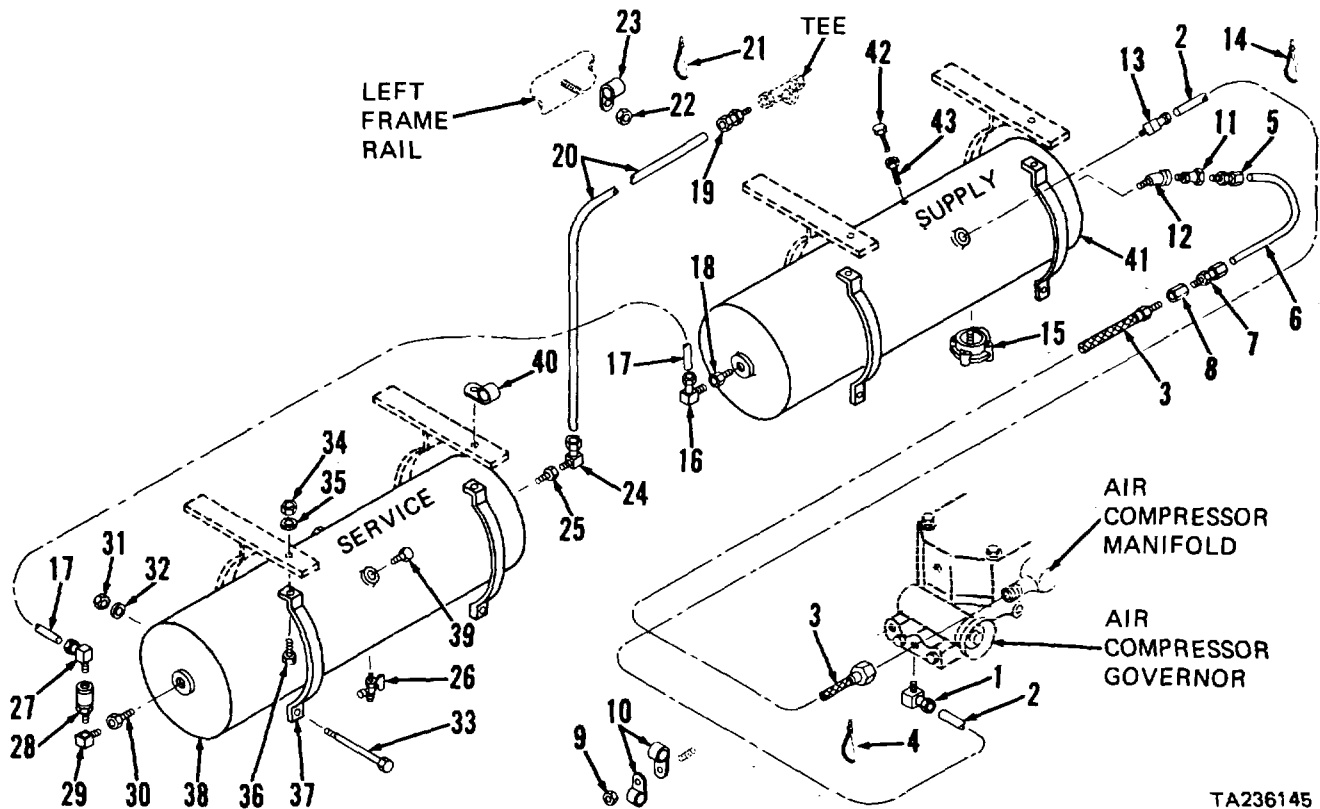

TA236145

KEY

- | | | |
|---------------------------|--------------------|-----------------------|
| 1. Elbow | 16. Elbow | 30. Bushing |
| 2. Tubing (RED) | 17. Tubing (BLK) | 31. Locknuts (4) |
| 3. Hose assembly | 18. Bushing | 32. Washers (4) |
| 4. Tie straps (5) | 19. Connector | 33. Capscrews (4) |
| 5. Fitting | 20. Tubing (BLK) | 34. Locknuts (4) |
| 6. Hose (BLK) | 21. Tie straps (2) | 35. Washers (4) |
| 7. Fitting | 22. Nut | 36. Capscrews (4) |
| 8. Coupling | 23. Clamp | 37. Brackets (4) |
| 9. Nut | 24. Elbow | 38. Service reservoir |
| 10. Clamps (2) | 25. Bushing | 39. Plugs (2) |
| 11. Swivel | 26. Drain cock | 40. Clamp |
| 12. Elbow | 27. Elbow | 41. Supply reservoir |
| 13. Elbow | 28. Check valve | 42. Safety valve |
| 14. Tie straps (2) | 29. Elbow | 43. Bushing |
| 15. Automatic drain valve | | |

2-51. AIR BRAKE SYSTEM MAINTENANCE (CONT)

b. Air Reservoirs (cont).

STEP	LOCATION	ITEM	ACTION	REMARKS
REMOVAL (cont)				
3	Transmis- sion mount	a. Coupling (8)	Remove	From hose assembly (3)
		b. Nut (9) and two clamps (10)	Remove	
		c. Hose assembly (3)	Remove	From tractor
4	Supply reservoir (41)	a. Swivel (11)	Remove	From elbow (13)
		b. Elbow (12)	Remove	
		c. Elbow (13)	Loosen nut	
		d. Tubing (2) with nut	Disconnect	
		e. Elbow (13)	Remove	From supply reservoir (41)
		f. Two tie straps (14)	Cut, remove, and discard	Note locations for installa- tion
		g. Tubing (2) with nuts	Remove	From tractor
		h. Automatic drain valve (15)	Remove	
		i. Elbow (16)	Loosen nut	From elbow (16)
		j. Tubing (17) with nut	Disconnect	
		k. Elbow (16) and bushing (18)	Remove	From supply reservoir (41)
5	Left hand frame rail	a. Connector (19)	Loosen nut	From connector (19)
		b. Tubing (20) with nut	Disconnect	
		c. Connector (19)	Remove	From tee
		d. Two tie straps (21)	Cut, remove, and discard	Note locations for installa- tion
		e. Nut (22) and clamp (23)	Remove	
6	Service reservoir (38)	a. Elbow (24)	Loosen nut	From elbow (24)
		b. Tubing (20) with nut	a. Disconnect b. Remove	
		c. Bushing (25)	Remove	From service reservoir (38)
		d. Drain cock (26)	Remove	
		e. Elbow (27)	Loosen nut	From elbow (27)
		f. Tubing (17) with nut	Disconnect	
		g. Elbow (27)	Remove	From check valve (28)

2-51. AIR BRAKE SYSTEM MAINTENANCE (CONT)
--

b. Air Reservoirs (cont).

STEP	LOCATION	ITEM	ACTION	REMARKS		
REMOVAL (cont)						
6 (cont)		h. Check valve (28), elbow (29), and bushing (30)	Remove	Note position of elbow (29) for installation		
		i. Service reservoir (38)	Support	Use transmission jack		
		j. Two locknuts (31), washers (32), and capscrews (33)	Remove			
		k. Two locknuts (34), washers (35), capscrews (36), and brackets (37)	Remove			
		l. Service reservoir (38)	Lower and	Use transmission jack remove		
		m. Two plugs (39)	Remove			
		n. Clamp (40)	Remove	From tubing (17)		
		o. Tubing (17) with nuts	Remove	From tractor		
		7	Supply reservoir (41)	a. Supply reservoir (41)	Remove	Repeat steps 6i thru 6l above
				b. Safety valve (42)	Remove	
c. Bushing (43)	Remove					
CLEANING						
8		a. Tubing (2, 17, and 20) and hoses (3 and 6)	Clean	Wipe with a clean cloth moistened with water		

2-51. AIR BRAKE SYSTEM MAINTENANCE (CONT)

- b. Air Reservoirs (cont).

STEP	LOCATION	ITEM	ACTION	REMARKS
------	----------	------	--------	---------

CLEANING (cont)

8
(cont)

WARNING

Dry cleaning solvent (P-D-680), used to clean parts is toxic and flammable. Wear protective goggles and gloves and use only in a well ventilated area. Avoid contact with skin, eyes, and clothes and don't breathe vapors. Do not use near open flame or excessive heat and don't smoke when using it. Failure to do so could cause serious injury. If you become dizzy while using cleaning solvent, get fresh air and medical attention immediately. If contact with skin or clothes is made, flush with large amounts of water. If contact with eyes is made, wash eyes with water and seek medical aid immediately. Compressed air must not exceed 30 psi. Wear safety glasses when drying parts with compressed air. Failure to do so could cause serious injury to eyes and possible blindness. If you hurt your eyes or if a foreign object is blown into your eyes, seek medical attention immediately.

b.	All other parts	Clean	Use cleaning solvent P-D-680; dry with compressed air
----	-----------------	-------	---

INSPECTION

9

a.	Tubing (2, 17, and 20) and hose (6)	Inspect	Replace if cracked, split, chafed, or deteriorated. Refer to step 10 below for hose (6) replacement; refer to step 11 below for tubing (2, 17, or 20) replacement
b.	Hose assembly (3)	Inspect	Replace assembly if cracked, split, deteriorated, or connectors damaged
c.	All other parts	Inspect	Replace if cracked, worn, distorted, or threads damaged. Refer to step 10 below for replacement of fittings (5 and 7); refer to step 11 below for replacement of connector (19) and elbows (1, 13, 16, 24, and 27)

2-51. AIR BRAKE SYSTEM MAINTENANCE (CONT)
--

b. Air Reservoirs (cont).

STEP	LOCATION	ITEM	ACTION	REMARKS
REPAIR				
10	Hose (6)	a. Fitting (5 or 7)	Place fitting socket in vise as shown	
		b. Mandrel assembly tool	Install in fitting nipple; tighten nut of fitting. Turn tool counterclockwise to remove fitting nipple and nut	
		c. Hose (6)	Turn hose (6) clockwise out of fitting (5 or 7) socket	

NOTE

Repeat steps 10a thru 10c above to remove remaining fitting (5 or 7) from hose (6).

WARNING

Dry cleaning solvent (P-D-680), used to clean parts is toxic and flammable. Wear protective goggles and gloves and use only in a well ventilated area. Avoid contact with skin, eyes, and clothes and don't breathe vapors. Do not use near open flame or excessive heat and don't smoke when using it. Failure to do so could cause serious injury. If you become dizzy while using cleaning solvent, get fresh air and medical attention immediately. If contact with skin or clothes is made, flush with large amounts of water. If contact with eyes is made, wash eyes with water and seek medical aid immediately.

d.	Fitting (5 or 7)	Clean	Use cleaning solvent P-D-680; allow to air dry. Use wire brush to remove all hose residue from socket and nipple of fittings
e.	Hose (6)	Cut to proper length	Use new hose; use old hose to determine proper length required. Cut hose square using fine tooth hacksaw
f.	Fitting (5 or 7)	Place fitting socket in vise as shown	
g.	Hose (6)	Screw hose counterclockwise into socket until hose bottoms; back hose off 1/4 to 1/2 turn	

2-51. AIR BRAKE SYSTEM MAINTENANCE (CONT)

b. Air Reservoirs (cont).

STEP	LOCATION	ITEM	ACTION	REMARKS
REPAIR (cont)				
10 (cont)		h. Mandrel assembly tool		Oil nipple threads, mandrel assembly tool, and inside of hose liberally using hydraulic oil. Tighten fitting nipple and nut on mandrel assembly tool. Apply oil to all parts
		i. Fitting (5 or 7)		Screw nipple clockwise into socket and hose. Allow 1/32 to 1/16 inch clearance between nut and socket so nut will swivel. Remove mandrel assembly tool from fitting. Remove fitting from vise

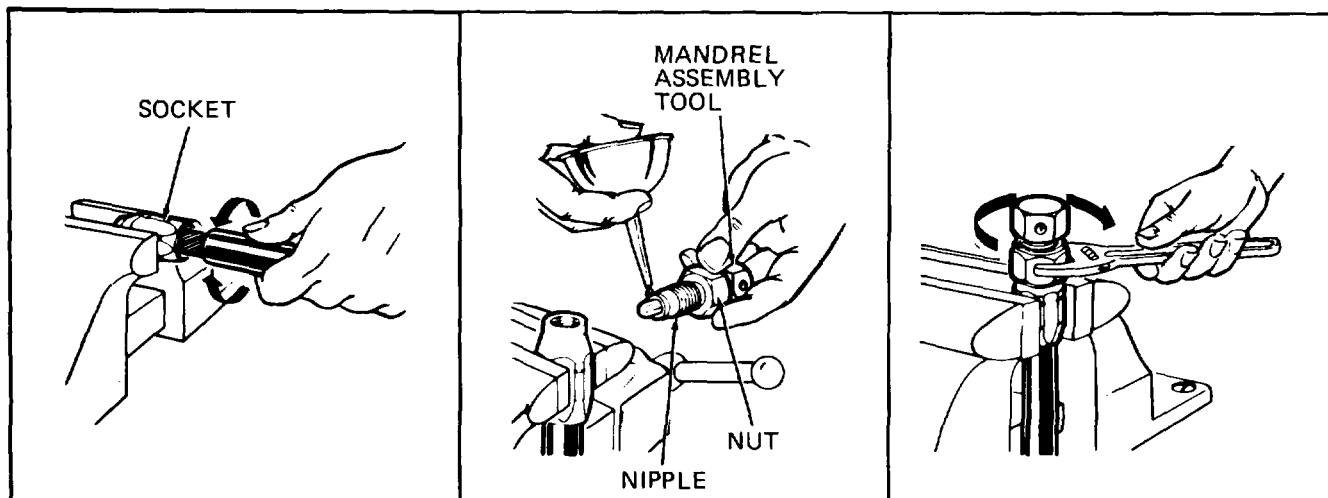

TA236149

NOTE

Repeat steps 10f thru 10i above to install remaining connector (5 or 7) on hose (6).

11	Tubing (2, 17, or 20)	a. Tubing (2, 17, or 20)	Cut	Between nut and sleeve
		b. Nut	Remove	Slide from tubing

2-51. AIR BRAKE SYSTEM MAINTENANCE (CONT)

b. Air Reservoirs (cont).

STEP	LOCATION	ITEM	ACTION	REMARKS
11 (cont)	c.	Insert	Remove, if necessary	Pull from tubing only if separated from fitting
	d.	Sleeve	Discard	

REPAIR (cont)

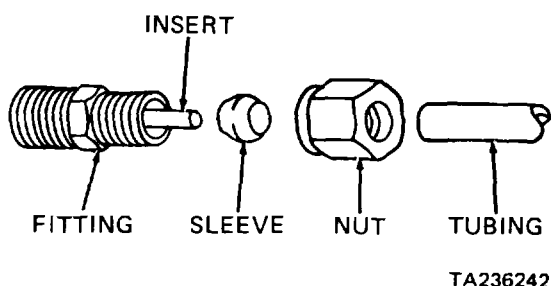

NOTE

Repeat steps 11a thru lid above to disassemble remaining fittings from tubing (2, 17, or 20).

e.	Tubing (2, 17 or 20)	Cut to proper length	Use new tubing; use old tubing to determine proper length
f.	Nut	Position	Slide onto tubing, threaded end out
g.	New sleeve	Position	Slide onto tubing
h.	Insert	Install, if necessary	Push into tubing only if separated from fitting

WARNING

Tubing must be installed over insert for secure connection. Installation of fitting without insert will allow air pressure to force tubing from fitting, resulting in dangerous loss of air pressure.

i.	Tubing	Install	Push onto insert until seated inside fitting
j.	Nut	Tighten	Hand tight only; prevents loss of sleeve before installation

NOTE

Repeat steps lie thru 11j above to install remaining fittings on tubing (2, 17, or 20).

2-51. AIR BRAKE SYSTEM MAINTENANCE (CONT)

b. Air Reservoirs (cont).

STEP	LOCATION	ITEM	ACTION	REMARKS
INSTALLATION				
12	Service reservoir (38)	a. Two plugs (39)	a. Tape b. Install	Wrap threads with Teflon tape In service reservoir (38)
		b. Tubing (17) with nuts	Route	
		c. Clamp (40)	Position	On tubing (17)
		d. Service reservoir (38)	Position	Use transmission jack to raise and position
		e. Two brackets (37), cap-tighten screws (36), washers (35), and locknuts (34)	Install and	Be sure clamp (40) is secured
		f. Two capscrews (33), washers (32), and locknuts (31)	Install and tighten	
		g. Transmission jack	Lower and remove	
		h. Bushing (30), elbow (29), and check valve (28)	a. Tape b. Install	Wrap threads with Teflon tape Tighten elbow (29) to position noted during removal
		i. Elbow (27)	a. Tape b. Install	Wrap threads with Teflon tape Tighten to position noted during removal
		j. Tubing (17) with nut	a. Connect b. Tighten nut	To elbow (27)
		k. Drain cock (26)	a. Tape b. Install	Wrap threads with Teflon tape
		l. Bushing (25)	a. Tape b. Install	Wrap threads with Teflon tape In service reservoir (38)
		m. Elbow (24)	a. Tape b. Install	Wrap threads with Teflon tape Tighten to position noted during removal
		n. Tubing (20) with nuts	a. Route b. Connect c. Tighten nut	To elbow (24)
13	Supply reservoir (41)	a. Bushing (43) and safety valve (42)	a. Tape b. Install	Wrap threads with Teflon tape In supply reservoir (41)
		b. Supply reservoir (41)	Install	Repeat steps 12d thru 12g above

2-51. AIR BRAKE SYSTEM MAINTENANCE (CONT)

b. Air Reservoirs (cont).

STEP	LOCATION	ITEM	ACTION	REMARKS		
INSTALLATION (cont)						
14	Left hand frame rail	a. Clamp (23) and nut (22)	Install and tighten			
		b. Two new tie straps (21)	Install	At locations noted during removal		
		c. Connector (19)	a. Tape	Wrap threads with Teflon tape		
		b. Install	In tee			
		d. Tubing (20) with nut	a. Connect	To connector (19)		
			b. Tighten nut			
		15	Supply reservoir (41)	a. Bushing (18)	a. Tape	Wrap threads with Teflon tape
				b. Elbow (16)	b. Install	In supply reservoir (41)
	a. Tape			Wrap threads with Teflon tape		
	b. Install			Tighten to position noted during removal		
		c. Tubing (17) with nut	a. Connect	To elbow (16)		
		d. Automatic drain valve (15)	b. Tighten nut			
		e. Tubing (2) with nuts	a. Tape	Wrap threads with Teflon tape		
		f. Two new tie straps (14)	b. Install			
		g. Elbow (13)	Route			
			Install	At locations noted during removal		
			a. Tape	Wrap threads with Teflon tape		
			b. Install	Tighten to position noted during removal		
			a. Connect	To elbow (13)		
			b. Tighten nut			
			a. Tape	Wrap threads with Teflon tape		
			b. Install	Tighten elbow (12) to position noted during removal		
16	Transmission mount	a. Tubing (2) and hose assembly (3)	Route			
		b. Two clamps (10)	Install and position	On tubing (2) and hose assembly (3)		
		c. Nut (9)	Install and tighten			
		d. Coupling (8)	Install	Wrap hose assembly threads with Teflon tape		

2-51. AIR BRAKE SYSTEM MAINTENANCE (CONT)
--

b. Air Reservoirs (cont).

STEP	LOCATION	ITEM	ACTION	REMARKS
INSTALLATION (cont)				
17	Supply reservoir (41)	a. Fitting (7) with hose (6) b. Fitting (5) with hose (6)	a. Tape b. Connect Connect	Wrap threads with Teflon tape To coupling (8) To swivel (11)
18	Engine right side, air compressor(3)	a. Five new tie straps (4) b. Hose assembly c. Elbow (1) d. Tubing (2) with nut	Install Connect a. Tape b. Install a. Connect b. Tighten nut	At locations noted during removal To air compressor manifold Wrap threads with Teflon tape Tighten to position noted during removal To elbow (1)
19	Left hand frame rail	Heat shield	Install	Para 2-65d
20	Cab tilt pump	Cab	Lower	To normal operating position
21	Instrument panel	Key switch b. Turn off	a. Turn on	Start and run engine to restore air pressure Press engine stop button to shut down engine
22	Air reservoirs	All connections	Inspect	Check for leaks using soap solution; tighten or adjust as necessary

2-51. AIR BRAKE SYSTEM MAINTENANCE (CONT)

c. Low Air Pressure Switch.

This task covers: a. Removal c. Inspection
 b. Cleaning d. Installation

INITIAL SETUP

Tools

No. 1 Common Organizational Maintenance
 Tool Kit
 Screwdriver
 Combination wrench set
 Safety glasses

Equipment Condition

Paragraph	Condition Description
	Vehicle parked on level surface, engine off, and parking brake applied. Key switch off and key removed.
	Cab tilted 45 degrees.
2-41h(1)	All air pressure relieved.

Materials/Parts

Cleaning solvent	Item 1, Appendix C
Clean cloths	Item 2, Appendix C
Sealant	Item 38, Appendix C

Personnel Required

Wheel Vehicle Mechanic MOS 63B

STEP	LOCATION	ITEM	ACTION	REMARKS
------	----------	------	--------	---------

REMOVAL

NOTE

Tag and identify all electrical leads before removing and disconnecting.

1	Brake control valve	a. Electrical lead (2)	Tag	
		b. Screw (1)	Remove	
		c. Electrical lead (2)	Disconnect	
		d. Two electrical leads (4 and 5)	Tag	
		e. Screw (3)	Remove	
		f. Two electrical leads (4 and 5)	Disconnect	
		g. Low air pressure switch (6)	Remove	From tee; use wrench on base of switch

2-51. AIR BRAKE SYSTEM MAINTENANCE (CONT)

- c. Low Air Pressure Switch.

KEY

- 1. Screw
- 2. Electrical lead
- 3. Screw
- 4. Electrical lead (BRN/WHT)
- 5. Electrical lead (RED)
- 6. Low air pressure switch

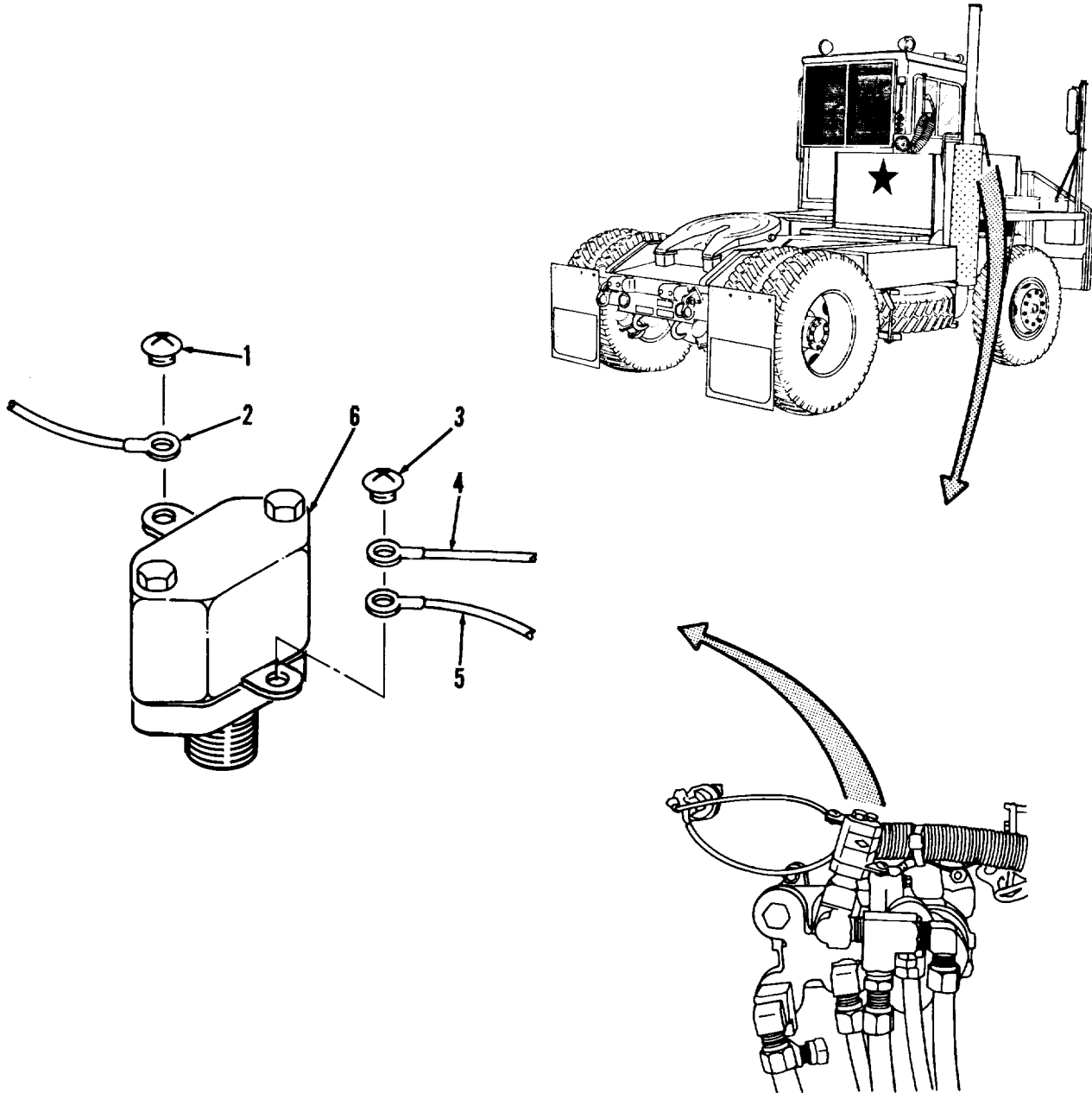

2-51. AIR BRAKE SYSTEM MAINTENANCE (CONT)
--

- c. Low Air Pressure Switch.

STEP	LOCATION	ITEM	ACTION	REMARKS
CLEANING				
2		a. Electrical leads (2, 4, and 5) and low air pressure switch (6)	Clean	Wipe with clean, dry cloth only
<u>WARNING</u>				
<p>Dry cleaning solvent (P-D-680), used to clean parts is toxic and flammable. Wear protective goggles and gloves and use only in a well ventilated area. Avoid contact with skin, eyes, and clothes and don't breathe vapors. Do not use near open flame or excessive heat and don't smoke when using it. Failure to do so could cause serious injury. If you become dizzy while using cleaning solvent, get fresh air and medical attention immediately. If contact with skin or clothes is made, flush with large amounts of water. If contact with eyes is made, wash eyes with water and seek medical aid immediately. Compressed air must not exceed 30 psi. Wear safety glasses when drying parts with compressed air. Failure to do so could cause serious injury to eyes and possible blindness. If you hurt your eyes or if a foreign object is blown into your eyes, seek medical attention immediately.</p>				
		b. Screws (1 and 3)	Clean	Use cleaning solvent P-D-680; dry thoroughly with compressed air
INSPECTION				
3		a. Low air pressure switch (6)	Inspect	Replace if damaged or inoperative
		b. Three electrical leads (2, 4, and 5)	Inspect	Replace if insulation cracked or cut, or if conductors corroded or broken
		c. Screws (1 and 3)	Inspect	Replace if cracked, bent, distorted, or threads damaged

2-51. AIR BRAKE SYSTEM MAINTENANCE (CONT)

c. Low Air Pressure Switch.

STEP	LOCATION	ITEM	ACTION	REMARKS
INSTALLATION				
4	Brake control valve	a. Low air pressure switch (6)	a. Seal	Apply sealant to first three threads of switch
		b. Electrical lead (2)	b. Install Position	On tee As tagged
		c. Screw (1)	Install and tighten	Secures electrical lead (2)
		d. Two electrical leads (4 and 5)	Position	As tagged
		e. Screw (3)	Install and tighten	Secures electrical leads (4 and 5)

2-51. AIR BRAKE SYSTEM MAINTENANCE (CONT)

d. Brake Air Chambers.

(1) Front Axle Brakes Air Chambers.

- This task covers:
- | | |
|----------------|-----------------|
| a. Removal | e. Repair |
| b. Disassembly | f. Reassembly |
| c. Cleaning | g. Installation |
| d. Inspection | |

INITIAL SETUP

Tools

No. 1 Common Organizational Maintenance

Tool Kit

- Adjustable open end wrench
- Socket wrench set
- Combination wrench set
- Drill set
- Safety glasses

Automotive Mechanic's Tool Kit

- Hammer
- Punch

Automotive Maintenance Tool Kit

- Electric drill

Materials/Parts

- | | | |
|----------------------|----------|------------|
| Cleaning solvent | Item 1, | Appendix C |
| Clean cloths | Item 2, | Appendix C |
| Non-hardening sealer | Item 10, | Appendix C |

- Detergent Item 27, Appendix C
- Housing boot parts kit FSCM 78500 PN MPS2002
- Two wooden blocks

Personnel Required

Two Wheel Vehicle Mechanics MOS 63B

Equipment Condition

Paragraph Condition Description

Parked on level surface; parking brake applied; engine off. Chassis front raised; rear wheels blocked. All air pressure relieved.

STEP	LOCATION	ITEM	ACTION	REMARKS
------	----------	------	--------	---------

REMOVAL

- | | | | |
|---|------------|----------------------|--------------------|
| 1 | Front axle | a. Collet nut (1) | Loosen |
| | | b. Brake air chamber | Unscrew and remove |
| | | c. Collet nut (1) | Remove |

REMOVE TIRE AND WHEEL (PARA 2-57)

DISCONNECT HOSES, REMOVE FITTINGS (PARA 2-51a)

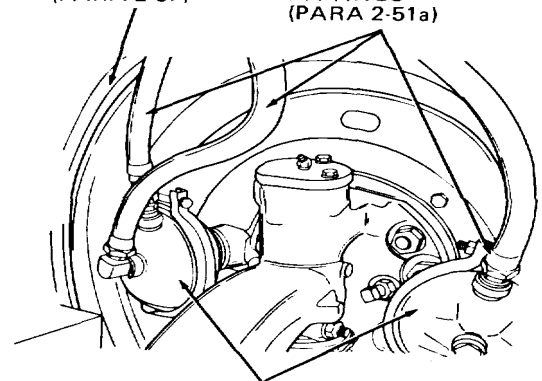

BRAKE AIR CHAMBERS

TA236147

2-51. AIR BRAKE SYSTEM MAINTENANCE (CONT)

d. Brake Air Chambers.

(1) Front Axle Brakes Air Chambers (cont).

KEY

1. Collet nut
2. Nut
3. Bolt
4. Ring clamp
5. Pressure housing
6. Non-pressure housing
7. Diaphragm
8. Push rod assembly
9. Wedge guide
10. Rivets (4)
11. Retainer
12. Boot
13. Plug

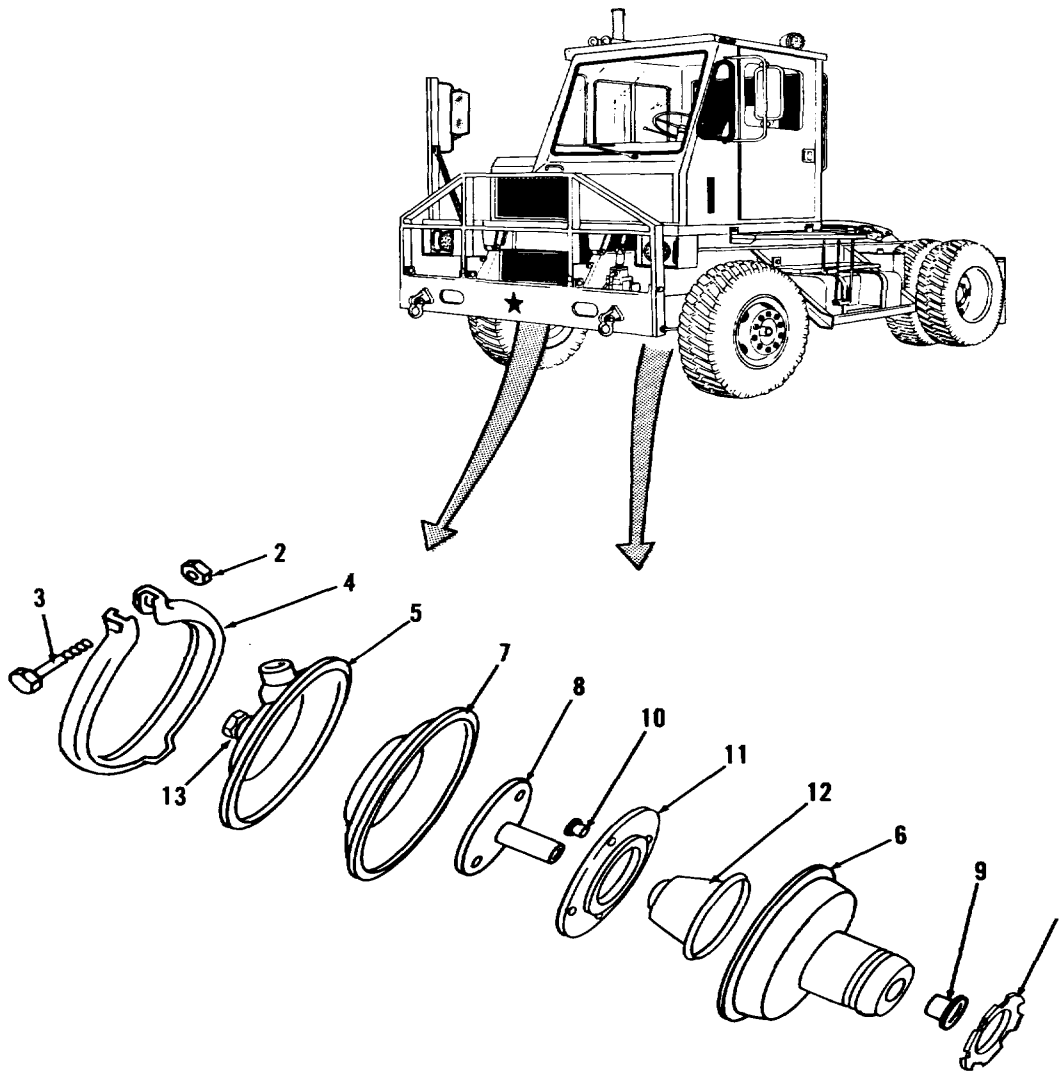

TA236146

2-51. AIR BRAKE SYSTEM MAINTENANCE (CONT)

d. Brake Air Chambers.

(1) Front Axle Brakes Air Chambers.

STEP	LOCATION	ITEM	ACTION	REMARKS
DISASSEMBLY				
2	Non-pressure housing (6)	a. Plug (13)	Remove	From air chamber mounted at rear of wheel end
		b. Nut (2) and bolt (3)	Remove	
		c. Ring clamp (4)	Spread; remove	
		d. Pressure housing (5) and non-pressure housing (6)	Separate	
		e. Diaphragm (7), push rod assembly (8), and wedge guide (9)	Remove from housings (5 and 6)	

NOTE

Do not remove rivets (10), retainer (11), or boot (12) unless necessary for replacement.

CLEANING

3	a. Diaphragm (7)	Clean	Use clean cloth, moistened with detergent
	b. Non-pressure housing (6) and retainer (11)	Clean	Wipe with clean dry cloth

WARNING

Dry cleaning solvent (P-D-680), used to clean parts is toxic and flammable. Wear protective goggles and gloves and use only in a well ventilated area. Avoid contact with skin, eyes, and clothes and don't breathe vapors. Do not use near open flame or excessive heat and don't smoke when using it. Failure to do so could cause serious injury. If you become dizzy while using cleaning solvent, get fresh air and medical attention immediately. If contact with skin or clothes is made, flush with large amounts of water. If contact with eyes is made, wash eyes with water and seek medical aid immediately.

2-51. AIR BRAKE SYSTEM MAINTENANCE (CONT)

d. Brake Air Chambers.

(1) Front Axle Brakes Air Chambers.

STEP	LOCATION	ITEM	ACTION	REMARKS
------	----------	------	--------	---------

CLEANING (cont)

3
(cont)

WARNING

Compressed air must not exceed 30 psi. Wear safety glasses when drying parts with compressed air. Failure to do so could cause serious injury to eyes and possible blindness. If you hurt your eyes or if a foreign object is blown into your eyes, seek medical attention immediately.

		c. All remaining parts	Clean	Use cleaning solvent P-D-680; dry with compressed air
--	--	------------------------	-------	---

INSPECTION

4		a. Ring clamp (4), push rod (8), and wedge guide (9)	Inspect	Replace if cracked, bent, or distorted
		b. Diaphragm (7)	Inspect	Replace if torn or deteriorated
		c. Retainer (11) and boot (12)	Inspect	Replace if cracked, bent, or if boot (12) is damaged or deteriorated (see step 5 below)
		d. All remaining parts	Inspect	Replace if cracked, or if threads damaged

REPAIR

5	Non-pressure housing (6)	a. Non-pressure housing (6)	Clamp	In vise. Use wooden blocks against vice jaws to protect housing. Clamp so that retainer (11) faces up
		b. Four rivets (10)	Remove	Use drill of diameter smaller than rivets

2-51. AIR BRAKE SYSTEM MAINTENANCE (CONT)

d. Brake Air Chambers.

(1) Front Axle Brakes Air Chambers.

STEP	LOCATION	ITEM	ACTION	REMARKS
------	----------	------	--------	---------

REPAIR (cont)

5 (cont)		c. Retainer (11) and non-pressure housing (6)	Separate	Remove boot (12). Discard retainer (11) and boot (12)
-------------	--	---	----------	---

NOTE

Housing boot parts kit includes four rivets (10), retainer (11), and boot (12).

		d. New boot (12)	Position	Inside non-pressure housing (6)
		e. New retainer (11)	Position	Place lip of retainer (11) against lip of boot (12)
		f. New boot (12) and new retainer (11)	Align	Match rivet holes with corresponding holes in non-pressure housing (6). Temporarily secure boot and retainer to housing with two bolts and nuts in opposite rivet holes
		g. Two new rivets (10)	Install	Use flat head drift and hammer to install rivets in two remaining holes
		h. Two temporary bolts and nuts	Remove	
		i. Two new rivets (10)	Install	Use flat head drift and hammer to install rivets in two remaining rivet holes
		j. Non-pressure housing (6)	Remove	From vise

REASSEMBLY

6	Non-pressure housing (6)	a. Push rod assembly (8)	Install	Through retainer (11), boot (12), and non-pressure housing (6)
---	--------------------------	--------------------------	---------	--

2-51. AIR BRAKE SYSTEM MAINTENANCE (CONT)

d. Brake Air Chambers.

(1) Front Axle Brakes Air Chambers.

STEP	LOCATION	ITEM	ACTION	REMARKS
REASSEMBLY (cont)				
6 (cont)		b. Wedge guide (9) bly (8)	Install	Onto end of push rod assembly
		c. Diaphragm (7)	Install	In non-pressure housing (6)
		d. Pressure housing (5)	Install	Over diaphragm (7)
		e. Ring clamp (4)	Install	Over flanges of pressure housing (5) and non-pressure housing (6)
		f. Bolt (3) and nut (2)	Install	Do not tighten

NOTE

In the next step, taper of collet nut (1) must be facing end of tube on non-pressure housing (6).

		g. Collet nut (1)	Install	On tube of non-pressure housing (6)
--	--	-------------------	---------	-------------------------------------

INSTALLATION

7	Axle end	a. Non-hardening sealer	Apply	To first three threads of tube on non-pressure housing (6)
		b. Brake air chambers	Install	Into spider until brake air chamber bottoms against spider. Do not tighten collet nut (1)
		c. Pressure housing (5)	Rotate	Align inlet port with brake air line
		d. Nut (2)	Tighten	
		e. Fittings and air lines	Install	Para 2-51a
		f. Plug (13)	Install	In port of air chamber mounted at rear of axle end
8	Cab	a. Key switch	Turn on	Start engine to build up air pressure
		b. Brakes	Apply	Depress brakes fully and hold

2-51. AIR BRAKE SYSTEM MAINTENANCE (CONT)

d. Brake Air Chambers.

(1) Front Axle Brakes Air Chambers.

STEP	LOCATION	ITEM	ACTION	REMARKS
INSTALLATION (cont)				
9	Axle end	a. Collet nut (1)	Tighten	Hand-tighten against spider; then use drift and hammer to tighten an additional 3/16 turn
		b. Connections	Inspect	Check for leaks; tighten as necessary
10	Instrument panel	Key switch	Turn off	
11	Axle end	Wheel and tire	Install	Para 2-57

NOTE

Repeat steps 1 thru 11 for remaining front axle brakes air chamber.

2-51. AIR BRAKE SYSTEM MAINTENANCE (CONT)

d. Brake Air Chambers.

(2) Rear Axle Brakes Air Chambers.

- This task covers:
- a. Removal
 - b. Disassembly
 - c. Cleaning
 - d. Inspection
 - e. Reassembly
 - f. Installation
 - g. Adjustment

INITIAL SETUP

Tools

No.1 Common Organizational Maintenance

Tool Kit

- Adjustable open end wrench
- Socket wrench set
- Screwdriver
- Torque wrench
- Safety glasses

Automotive Mechanic's Tool Kit

- Pliers
- Punch
- Rule

Automotive jack

Two jack stands

Flashlight

Soft-faced vise

- O-ring FSCM 50153 PN 11M114
- Diaphragm FSCM 50153 PN 1126M009
- Cotter pin FSCM 50153 PN 11M063

Personnel Required

Two Wheel Vehicle Mechanics MOS 63B

Equipment Condition

Paragraph Condition Description

- 2-41h(1) Vehicle parked on level surface, engine off, and front wheels blocked.
- 2-51a All air pressure relieved. Lines and fittings removed from rear axle brakes air chambers.

Materials/Parts

Cleaning solvent

Item 1, Appendix C

Clean cloths

Item 2, Appendix C

STEP	LOCATION	ITEM	ACTION	REMARKS
------	----------	------	--------	---------

REMOVAL

1	Rear axle	a. Dust plug (1)	Remove	From cover of spring chamber assembly (12)
		b. Nut (2) and washer (3)	Remove	From release stud (4)
		c. Release stud (4)	a. Remove b. Insert	From adapter (13) Cross pin end through cover of spring chamber assembly (12); then turn release stud clockwise 1/4 turn to secure cross pin in pressure plate (31)

2-51. AIR BRAKE SYSTEM MAINTENANCE (CONT)

d. Brake Air Chambers.

(2) Rear Axle Brakes Air Chambers.

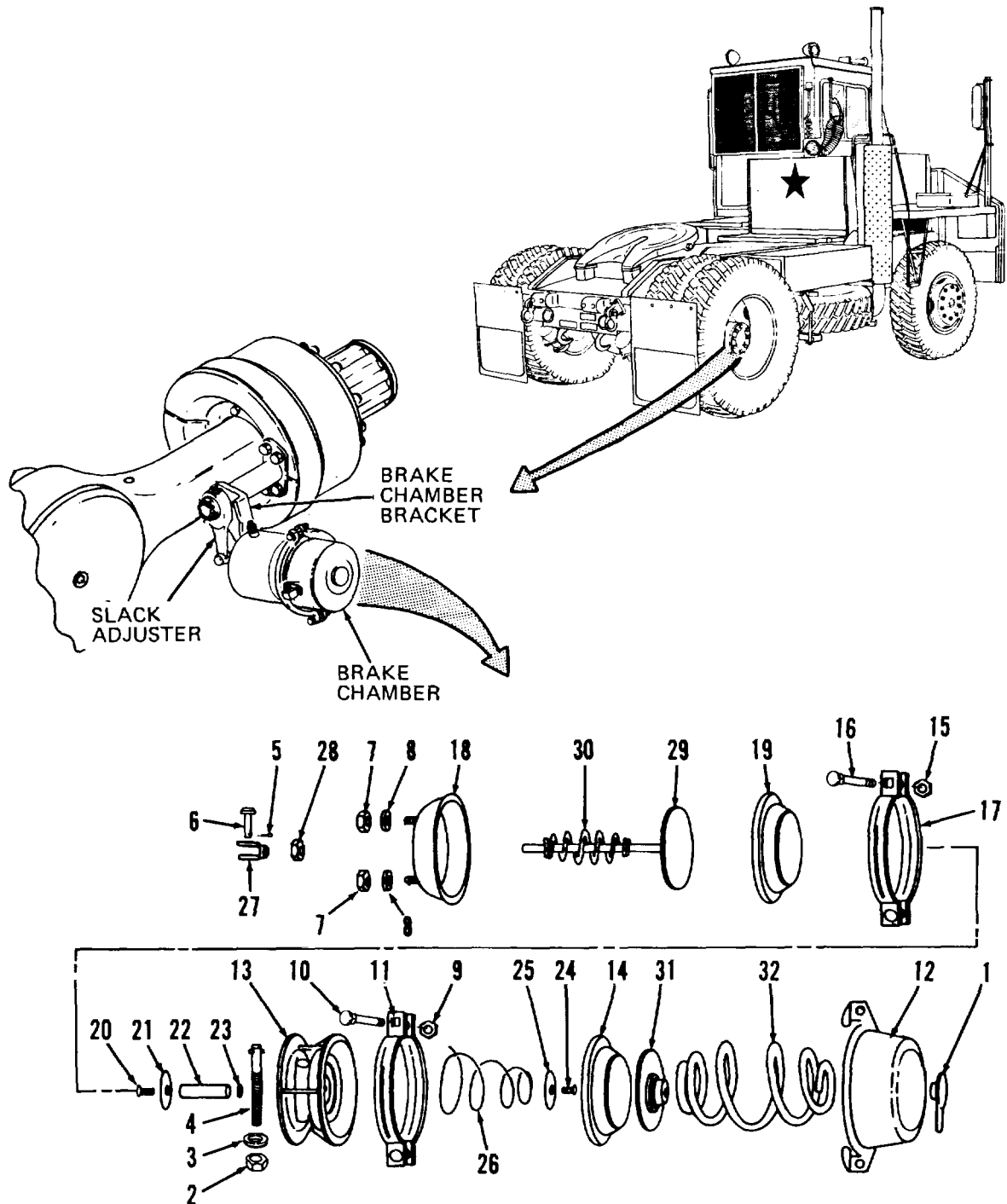

TA236252

2-51. AIR BRAKE SYSTEM MAINTENANCE (CONT)

d. Brake Air Chambers.

(2) Rear Axle Brakes Air Chambers.

KEY

- | | | |
|--------------------------|-----------------------------|------------------------|
| 1. Dust plug | 12. Spring chamber assembly | 23. O-ring |
| 2. Nut | 13. Adapter | 24. Screw |
| 3. Washer | 14. Diaphragm | 25. Plate |
| 4. Release stud | 15. Nuts (2) | 26. Spring |
| 5. Cotter pin | 16. Carriage bolts (2) | 27. Clevis |
| 6. Clevis pin | 17. Clamp assemblies (2) | 28. Nut |
| 7. Nuts (2) | 18. Housing assembly | 29. Push rod |
| 8. Lock washers (2) | 19. Diaphragm | 30. Spring |
| 9. Nuts (2) | 20. Screw | 31. Pressure plate |
| 10. Carriage bolts (2) | 21. Plate | 32. Compression spring |
| 11. Clamp assemblies (2) | 22. Push rod adapter | |

STEP	LOCATION	ITEM	ACTION	REMARKS
------	----------	------	--------	---------

REMOVAL (cont)

1 (cont)	d.	Washer (3) and nut (2)	Install	On release stud (4). Tighten nut (2) with wrench to completely cage compression spring (32)
	e.	Push rod (29)	Observe	While tightening nut (2). Push rod (29) should retract into housing assembly (18) as nut is being tightened

WARNING

Do not attempt to remove release stud (4) from spring chamber assembly (12) at this time. Compression spring (32) is under extreme tension. Failure to follow this procedure could result in severe injury. If you are injured, seek medical aid immediately.

f.	Cotter pin (5) and clevis pin (6)	Remove	Discard cotter pin (5)
g.	Clevis (27)	Disconnect	From slack adjuster
h.	Two nuts (7) and lock washers (8)	Remove	
i.	Brake air chamber	Remove	From brake chamber bracket

2-51. AIR BRAKE SYSTEM MAINTENANCE (CONT)
--

d. Brake Air Chambers.

(2) Rear Axle Brakes Air Chambers.

STEP	LOCATION	ITEM	ACTION	REMARKS
------	----------	------	--------	---------

DISASSEMBLY

WARNING

Before proceeding, make certain that release stud (4) is properly installed. Do not remove nuts (9) and carriage bolts (10) unless compression spring (32) is caged. Failure to follow this procedure could result in severe injury. If you are injured, seek medical aid immediately.

STEP	LOCATION	ITEM	ACTION	REMARKS
2	Rear axle brake air chamber	a. Two nuts (9) and carriage bolts (10)	Remove	
		b. Two clamp assemblies (11)	Remove	
		c. Spring chamber assembly (12) and adapter (13)	Separate	
		d. Diaphragm (14)	Remove and discard	
		e. Two nuts (15) and carriage bolts (16)	Remove	
		f. Two clamp assemblies (17)	Remove	
		g. Housing assembly (18) and adapter (13)	Separate	
		h. Diaphragm (19)	Remove and discard	
		i. Screw (20), plate (21), push rod adapter (22), and O-ring (23)	Remove	Discard O-ring (23)
		j. Screw (24), plate (25), and spring (26)	Remove	

2-51. AIR BRAKE SYSTEM MAINTENANCE (CONT)

d. Brake Air Chambers.

(2) Rear Axle Brakes Air Chambers.

STEP	LOCATION	ITEM	ACTION	REMARKS
DISASSEMBLY (cont)				
2 (cont)		k. Clevis (27) and nut (28)	Remove	
		l. Push rod (29) and spring (30)	Remove and separate	
		m. Spring chamber assembly (12)	Position	In soft-faced vise. Wear safety glasses; tighten vise to contact pressure plate (31) and spring chamber assembly (12)

WARNING

Observe caution when removing nut (2), washer (3), and release stud (4). Compression spring (32) is under extreme tension. Failure to follow this procedure could result in extreme injury. If you are injured, seek medical aid immediately.

		n. Nut (2) and washer (3)	Remove	
		o. Release stud (4)	Remove	Turn counterclockwise 1/4 turn to disengage from pressure plate (31); then withdraw release stud
		p. Soft-faced vise	Open slowly	Relieves spring tension
		q. Pressure plate (31) and spring chamber assembly (12)	Separate	
		r. Compression spring (32)	Remove	

CLEANING

3		a. Dust plug (1)	Clean	Use clean cloth, moistened with water
---	--	------------------	-------	--

2-51. AIR BRAKE SYSTEM MAINTENANCE (CONT)

d. Brake Air Chambers.

(2) Rear Axle Brakes Air Chambers.

STEP	LOCATION	ITEM	ACTION	REMARKS
------	----------	------	--------	---------

CLEANING (cont)

3
(cont)

WARNING

Dry cleaning solvent (P-D-680), used to clean parts is toxic and flammable. Wear protective goggles and gloves and use only in a well ventilated area. Avoid contact with skin, eyes, and clothes and don't breathe vapors. Do not use near open flame or excessive heat and don't smoke when using it. Failure to do so could cause serious injury. If you become dizzy while using cleaning solvent, get fresh air and medical attention immediately. If contact with skin or clothes is made, flush with large amounts of water. If contact with eyes is made, wash eyes with water and seek medical aid immediately. Compressed air must not exceed 30 psi. Wear safety glasses when drying parts with compressed air. Failure to do so could cause serious injury to eyes and possible blindness. If you hurt your eyes or if a foreign object is blown into your eyes, seek medical attention immediately.

b. All other parts	Clean	Use cleaning solvent P-D-680; dry thoroughly with compressed air
--------------------	-------	--

INSPECTION

4

a. Dust plug (1)	Inspect	Replace if cracked or deteriorated
b. Springs (26, 30, and 33)	Inspect	Replace if cracked, deformed, or permanently set
c. All other parts	Inspect	Replace if cracked, bent, distorted, or threads damaged

REASSEMBLY

5

Rear axle brake air chamber

a. Compression spring (32)	Install	In spring chamber assembly (12)
b. Pressure plate (31)	Position	Inside compression spring (32)

2-51. AIR BRAKE SYSTEM MAINTENANCE (CONT)

d. Brake Air Chambers.

(2) Rear Axle Brakes Air Chambers.

STEP	LOCATION	ITEM	ACTION	REMARKS
REASSEMBLY (cont)				
5 (cont)		c. Pressure plate (31), compression spring (32), and spring chamber assembly (12)	Position	In soft-faced vise. Wear safety glasses; tighten vise to contact pressure plate (31) and spring chamber assembly (12)
		d. Soft-faced vise	Tighten	
		e. Release stud (4)	Insert	Cross pin end through cover of spring chamber assembly (12); then turn release stud clockwise 1/4 turn to secure cross pin in pressure plate (31)
		f. Washer (3) and nut (2)	Install	On release stud (4). Tighten nut (2) with wrench to completely cage
	compression	g. Spring (30)	Install	spring (32)
		h. Push rod (29)	Install	On push rod (29)
		i. Nut (28) and clevis (27)	Install	Through housing assembly (18)
		j. New O-ring (23)	Install	On push rod (29)
		k. Push rod adapter (22)	Install	In adapter (13)
		l. Plate (21) and screw (20)	Install	In adapter (13)
		m. Spring (26), plate (25), and screw (24)	Install	
		n. New diaphragm (19)	Position	On housing assembly (18)
		o. Adapter (13)	Align	On diaphragm (19)
		p. Housing assembly (18) and adapter (13)	Mate	
		q. Two clamp assemblies (17)	Install	
		r. Two carriage bolts (16) foot torque and nuts (15)	Install	Tighten nuts to 20-30 pounds
		s. New diaphragm (14)	Position	On adapter (13)

2-51. AIR BRAKE SYSTEM MAINTENANCE (CONT)

d. Brake Air Chambers.

(2) Rear Axle Brakes Air Chambers.

STEP	LOCATION	ITEM	ACTION	REMARKS
------	----------	------	--------	---------

REASSEMBLY (cont)

5
(cont)

WARNING

Do not attempt to remove release stud (4) from spring chamber assembly (12) at this time. Compression spring (32) is under extreme tension. Failure to follow this procedure could result in severe injury. If you are injured, seek medical aid immediately.

t.	Spring chamber assembly (12)	a.	Align	On diaphragm (14)
u.	Two clamp assemblies (11)	b.	Mate	With adapter (13)
v.	Two carriage bolts (10) and nuts (9)		Install	Tighten nuts to 20-30 pounds foot torque

INSTALLATION

6	Rear axle	a.	Brake air chamber	Position	On brake chamber bracket	
		b.	Two lock washers (8) and nuts (7)	Install	Tighten nuts to 80-100 pounds foot torque	
		c.	Clevis (27)	Connect	To slack adjuster	
		d.	Clevis pin (6)	Install		
		e.	New cotter pin (5)	Insert and spread		
		f.	Nut (2) and washer (3)	Remove		
		g.	Release stud (4)	a.	Remove	Turn counterclockwise 1/4 turn to disengage from pressure plate (31); then withdraw release stud
		h.	Washer (3) and nut (2)	b.	Insert	In adapter (13)
		i.	Dust plug (1)	Install	On release stud (4)	Press firmly

2-51. AIR BRAKE SYSTEM MAINTENANCE (CONT)

d. Brake Air Chambers.

(2) Rear Axle Brakes Air Chambers.

STEP	LOCATION	ITEM	ACTION	REMARKS
ADJUSTMENT				
7	Rear axle	Air lines and fittings	Install	Para 2-51a
8	Instrument panel	Key switch	Turn on	Run engine several minutes to restore air pressure; then stop engine
9	Tractor	a. Parking brake	Release	Be sure front wheels are blocked Under rear axle ends
		b. Rear wheels	Raise	
		c. Two jack stands	Position	

WARNING

Before performing the following steps, be sure that axle ends are securely supported by jack stands. Failure to do so could cause tractor to fall on you causing serious injury or death.

10	Left rear brake air chamber	a. Clevis pin	Measure distance between centerline of clevis pin and face of brake air chamber. Distance should be 2.9 inches
----	-----------------------------	---------------	--

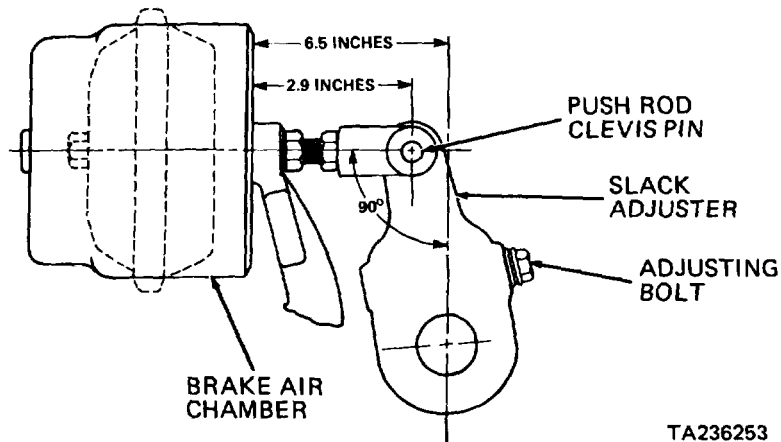

TA236253

2-51. AIR BRAKE SYSTEM MAINTENANCE (CONT)

d. Brake Air Chambers.

(2) Rear Axle Brakes Air Chambers.

STEP	LOCATION	ITEM	ACTION	REMARKS
ADJUSTMENT (cont)				
10 (cont)		b. Brake air chamber		Measure distance between face of brake air chamber, and a vertical through the centerline of the slack adjuster mounting hole. Distance should be 6.5 inches
NOTE				
If measurement in step 10a above is 2.9 inches, proceed to step 12 below. If measurement for left brake air chamber is not 2.9 inches, perform steps 1a thru 1g above, then proceed to step 11 below.				
11	Rear axle	a. Nut (28) b. Clevis (27)	Loosen	Adjust to obtain correct measurement. When correct measurement is obtained, perform steps 6c thru 6i above
NOTE				
After you complete steps 6c thru 6i, proceed to step 12 below.				
12	Slack adjuster	Adjusting bolt		Fully depress adjusting bolt lock collar. Turn adjusting bolt counterclockwise until there is strong resistance to drum rotation (if adjusting bolt rotates fully counterclockwise without strong resistance proceed to step 17); then rotate adjusting bolt clockwise until very light drum drag is felt. Left rear brake adjustment is now complete
NOTE				
Perform steps 10 thru 12 above, and all intermediate steps as necessary, to properly adjust right rear brake.				
13	Rear axle	Two jack stands	Remove.	Lower rear wheels to ground
14	Left rear brake air chamber	Push rod (29)		Use scribe to mark a reference line on push rod (29) near brake air chamber mounting bracket

2-51. AIR BRAKE SYSTEM MAINTENANCE (CONT)
--

d. Brake Air Chambers.

(2) Rear Axle Brakes Air Chambers.

STEP	LOCATION	ITEM	ACTION	REMARKS
ADJUSTMENT (cont)				
15	Cab	Key switch	Turn on to start engine. Have assistant apply service brakes	
16	Left rear brake air chamber	Push rod (29)	Measure distance of travel. Travel should not exceed 2 inches	
NOTE				
If travel of push rod (29) exceeds 2 inches, turn key switch off to stop engine; then perform steps 1a thru 1e above. After performing these steps, proceed to step 17 below.				
17	Rear axle	Slack adjusters	a. Remove (para 2-50b) b. Reposition on camshaft to decrease travel of brake air chamber push rod (29). Then perform step 12 above	
NOTE				
Perform steps 14 thru 17 above for right rear brake air chamber.				
18	Front wheels	Wheel blocks	Remove	

2-52. AIR BRAKE SYSTEM MAINTENANCE

- a. Servicing (Summary Procedure).

This job covers servicing of the air compressor assembly.

INITIAL SETUP

Tools

No.1 Common Organizational Maintenance

Tool Kit

- Combination wrench set
- Screwdriver
- Socket wrench set

Materials/Parts

- Clean cloths Item 2, Appendix C
- Detergent Item 27, Appendix C
- Methanol Item 39, Appendix C

Personnel Required

Wheel Vehicle Mechanic MOS 63B

Equipment Condition

Paragraph Condition Description

Parked on level surface; parking brake applied; engine off.
Cab tilted 45 degrees.

List of Tasks			
Task No.	Task	Task Ref.	Troubleshooting Ref. No. (Para)
1.	Service air strainer	2-52b	2-48
2.	Service alcohol evaporator	2-52c	2-48

2-52. AIR COMPRESSOR ASSEMBLY MAINTENANCE (CONT)

b. Air Strainer. This task covers servicing, removal, disassembly, cleaning, inspection, reassembly, and installation of the air strainer.

INITIAL SETUP

Tools

No. 1 Common Organizational Maintenance
Tool Kit
Socket wrench set
Screwdriver set
Safety glasses

Personnel Required

Wheel Vehicle Mechanic MOS 63B

Equipment Condition

Paragraph Condition Description

Materials/Parts

Cleaning solvent Item 1, Appendix C
Clean cloths Item 2, Appendix C
Detergent Item 27, Appendix C
Gasket FSCM 06853 PN 243430
Gasket FSCM 06853 PN 236959

Vehicle parked on level surface, engine off, and parking brake applied.
Cab tilted 45 degrees.
2-41h(l) Air pressure relieved.

STEP	LOCATION	ITEM	ACTION	REMARKS
------	----------	------	--------	---------

SERVICING

1	Air compressor	a. Two screws (1), washers (2), and cover (3)	Remove	
		b. Baffle (4) and filter element (5)	Remove	
2		Filter element (5)	a. Clean b. Inspect c. Install	Wash in mild detergent solution; allow to air dry Replace if torn or deteriorated In strainer body (8)
3	Air compressor	a. Baffle (4) b. Cover (3) c. Two washers (2) and screws (1)	Install Install Install and tighten	

REMOVAL

4	Air compressor	a. One capscrew (6) and lock washer (7) b. One capscrew (6) Loosen	Remove	
---	----------------	---	--------	--

2-52. AIR COMPRESSOR ASSEMBLY MAINTENANCE (CONT)

b. Air Strainer (cont).

1. Screws (2)
2. Washers (2)
3. Cover
4. Baffle
5. Filter element
6. Capscrews (2)
7. Lock washers (2)

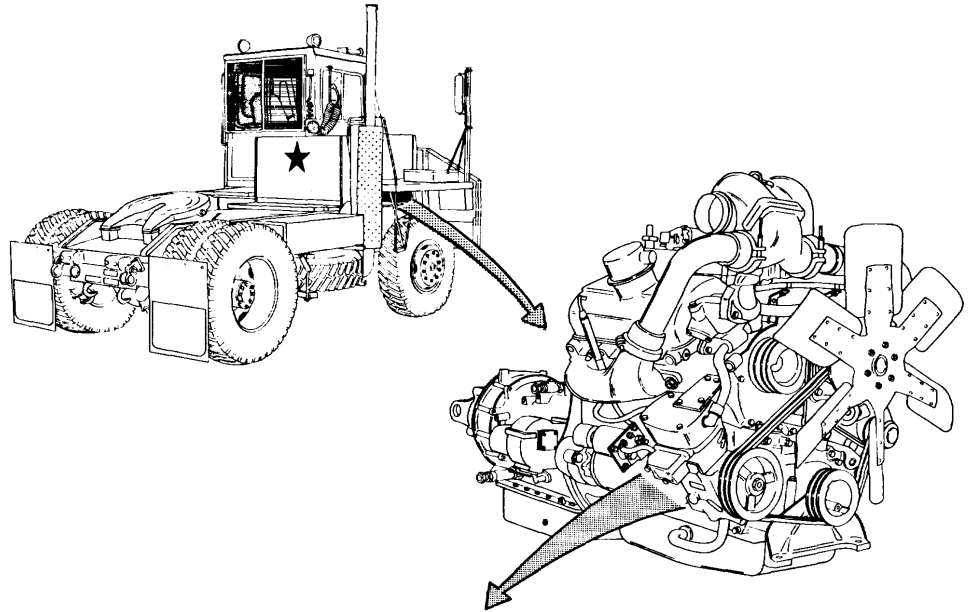

8. Strainer body
9. Gasket
10. Screws
11. Washers
12. base plate
13. Gasket
14. Baffle

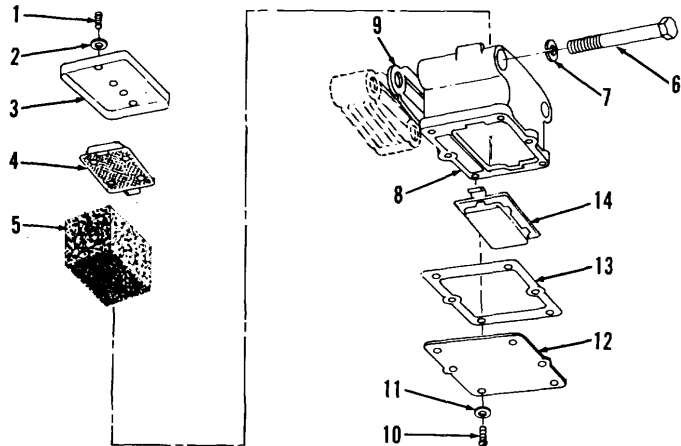

TA236254

2-52. AIR COMPRESSOR ASSEMBLY MAINTENANCE (CONT)

b. Air Strainer (cont).

STEP	LOCATION	ITEM	ACTION	REMARKS
REMOVAL (cont)				
4 (cont)		c. Strainer body (8) and gasket (9)	Rotate on loosened capscrew (6). Support adapter while rotating strainer body and gasket	
		d. One capscrew (6)	Install through adapter to support adapter	
		e. One capscrew (6) and lock washer (7)	Remove	Capscrew securing strainer body
		f. Strainer body (8)	Remove	
		g. Gasket (9)	Remove and discard	
DISASSEMBLY				
5	Strainer body (8), bottom	a. Six screws (10), and washers (11)	Remove	
		b. Base plate (12)	Remove	
		c. Gasket (13)	Remove and discard	
		d. Baffle (14)	Remove	
6	Strainer body (8), top	a. Two screws (1) and washers (2)	Remove	
		b. Cover (3)	Remove	
		c. Baffle (4) and filter element (5)	Remove	
CLEANING				
7		a. Filter element (5)	Clean	Wash in mild detergent solution; allow to air dry

2-52. AIR COMPRESSOR ASSEMBLY MAINTENANCE (CONT)

b. Air Strainer (cont).

STEP	LOCATION	ITEM	ACTION	REMARKS
CLEANING (cont)				
7			<u>WARNING</u>	
(cont)			Dry cleaning solvent (P-D-680), used to clean parts is toxic and flammable. Wear protective goggles and gloves and use only in a well ventilated area. Avoid contact with skin, eyes, and clothes and don't breathe vapors. Do not use near open flame or excessive heat and don't smoke when using it. Failure to do so could cause serious injury. If you become dizzy while using cleaning solvent, get fresh air and medical attention immediately. If contact with skin or clothes is made, flush with large amounts of water. If contact with eyes is made, wash eyes with water and seek medical aid immediately.	
		b. Remaining parts	Clean	Use cleaning solvent P-D-680; dry using clean cloths
INSPECTION				
8		a. Cover (3), baffles (4 and 14), and base plate (12)	Inspect for cracks dents bent condition	Replace if defects observed
		b. Strainer body (8)	Inspect for cracks breaks damaged threads	Replace if defects observed
		c. Filter element (5)	Inspect for tears deterioration	Replace if defects observed
		d. Remaining parts	Inspect for cracks damaged threads	Replace if defects observed
9	Air compressor	Adapter	Inspect	Check gasket between adapter and compressor. If adapter has loosened from gasket, replace gasket (para 2-52c)

2-52. AIR COMPRESSOR ASSEMBLY MAINTENANCE (CONT)

b. Air Strainer (cont).

STEP	LOCATION	ITEM	ACTION	REMARKS
REASSEMBLY				
10	Strainer body (8), top	a. Filter element (5) b. Baffle (4) c. Cover (3) d. Two washers (2) and screws (1)	Install Install Install Install and tighten	
11	Strainer body (8), bottom	a. Baffle (14) b. New gasket (13) c. Base plate (12) d. Six washers (11) and capscrews (10)	Install Install Install Install and tighten	
INSTALLATION				
12	Air compressor	a. Adapter b. One capscrew (6) c. New gasket (9) d. Strainer body (8) e. Two lock washers (7) and capscrews (6)	Support Remove Position Install Install and tighten	From adapter while supporting adapter On adapter
13	Vehicle, right side	Cab	Lower	To normal driving position

2-52. AIR COMPRESSOR ASSEMBLY MAINTENANCE (CONT)

c. Alcohol Evaporator.

- This task covers:
- a. Servicing
 - b. Removal
 - c. Disassembly
 - d. Cleaning
 - e. Inspection
 - f. Reassembly
 - g. Installation

INITIAL SETUP

Tools

No. 1 Common Organizational Maintenance

Tool Kit

- Socket wrench set
- Combination wrench set
- Safety glasses

Materials/Parts

- Cleaning solvent Item 1, Appendix C
- Clean cloths Item 2, Appendix C
- Methanol alcohol Item 39, Appendix C
- Gasket FSCM 06853 PN 243940
- O-ring FSCM 06853 PN 239071
- Filter FSCM 06853 PN 239139

Personnel Required

Wheel Vehicle Mechanic MOS 63B

Equipment Condition

Paragraph Condition Description

2-52b Parked on level surface; parking brake applied; engine off. Cab tilted 45 degrees (for evaporator removal).
Air strainer removed (for evaporator removal).

STEP	LOCATION	ITEM	ACTION	REMARKS
------	----------	------	--------	---------

SERVICING

1	Cab, right side	Engine hood	Unlatch and raise	
2	Fan shroud, right side, alcohol evaporator	a. Filler plug (17) b. Reservoir (8) c. Filler plug (17)	Remove Fill Install	With methanol alcohol
3	Cab, right side	Engine hood	Lower and latch	

REMOVAL

4	Engine, right side, front, air compressor	a. Nut (1) b. Tube (2) c. Adapter (3) d. Gasket (4) e. Connector (5)	Loosen Disconnect Remove Remove and discard Remove	From elbow (6)
---	---	--	--	----------------

2-52. AIR COMPRESSOR ASSEMBLY MAINTENANCE (CONT)

c. Alcohol Evaporator (cont).

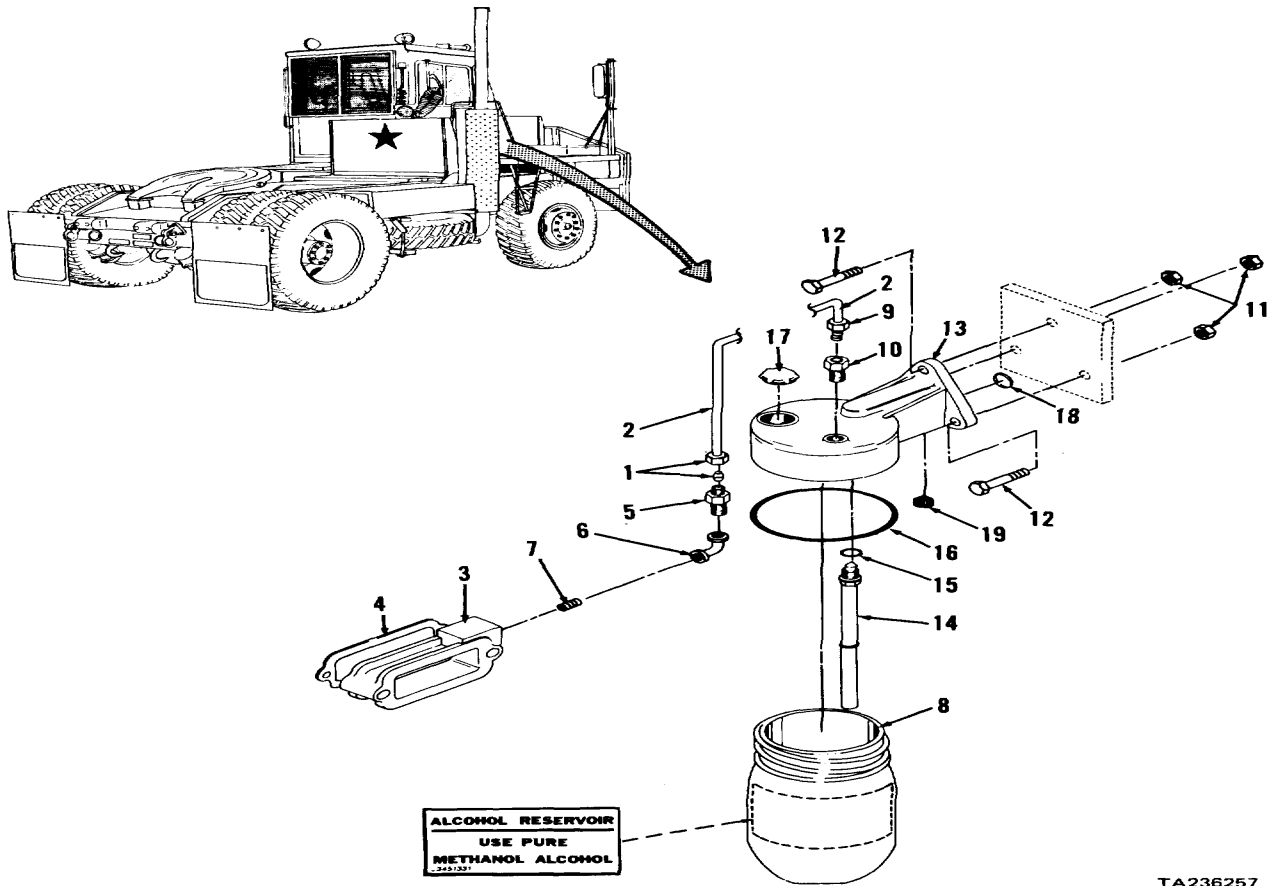

TA236257

KEY

- 1. Nut
- 2. Tube
- 3. Adapter
- 4. Gasket
- 5. Connector
- 6. Elbow
- 7. Nipple
- 8. Reservoir
- 9. Nut
- 10. Connector
- 11. Locknuts (3)
- 12. Capscrews (3)
- 13. Body
- 14. Evaporator tube
- 15. O-ring
- 16. Gasket
- 17. Filler plug
- 18. Plug
- 19. Filter

2-52. AIR COMPRESSOR ASSEMBLY MAINTENANCE (CONT)

c. Alcohol Evaporator (cont).

STEP	LOCATION	ITEM	ACTION	REMARKS
REMOVAL (cont)				
4 (cont)		f. Elbow (6)	Remove	From nipple (7)
		g. Nipple (7)	Remove	From adapter (3)
5	Alcohol evaporator	a. Reservoir (8)	Unscrew and remove	
		b. Nut (9)	Loosen	
		c. Tube (2)	Disconnect and remove	
		d. Connector (10)	Remove	From body (13)
		e. Three locknuts (11) and capscrews (12)	Remove	Support body (13)
		f. Body (13)	Remove	From vehicle
DISASSEMBLY				
6	Evaporator body (13)	a. Evaporator tube (14)	Remove	
		b. O-ring (15)	Remove and discard	
		c. Gasket (16)	Remove and discard	
		d. Plug (18)	Remove	
		e. Filter (19)	Remove and discard	
CLEANING				
7		a. Reservoir (8)	Clean	Use clean cloth moistened with methanol alcohol

WARNING

Dry cleaning solvent (P-D-680), used to clean parts is toxic and flammable. Wear protective goggles and gloves and use only in a well ventilated area. Avoid contact with skin, eyes, and clothes and don't breathe vapors. Do not use near open flame or excessive heat and don't smoke when using it. Failure to do so could cause serious injury. If you become dizzy while using cleaning solvent, get fresh air and medical attention immediately. If contact with skin or clothes is made, flush with large amounts of water. If contact with eyes is made, wash eyes with water and seek medical aid immediately.

2-52. AIR COMPRESSOR ASSEMBLY MAINTENANCE (CONT)

c. Alcohol Evaporator (cont).

STEP	LOCATION	ITEM	ACTION	REMARKS
CLEANING (cont)				
7 (cont)		b. Remaining parts	Clean	Use cleaning solvent P-D-680; dry using clean cloths
INSPECTION		a. Tubing (2)	Inspect for: cracks dents splits	Replace as necessary
8		b. Adapter (3)	Inspect for: cracks warpage damage	Replace as necessary
		c. Reservoir (8)	Inspect for: cracks chipping	Replace as necessary
		d. Evaporator tube (14)	Inspect for: cracks dents bent condition	Replace as necessary
		e. Remaining parts	Inspect for: cracks breaks damaged threads	Replace as necessary
REASSEMBLY				
9	Evaporator body (13)	a. New filter (19)	Install	
		b. Plug (18)	Install	
		c. New gasket (16)	Install	
		d. New O-ring (15)	Install	
		e. Connector (10)	Install	
		f. Evaporator tube (14)	Install	
		g. Evaporator body (13)	Position	On vehicle
		h. Three capscrews (12) and lock- nuts (11)	Install	Secures evaporator body (13)

2-52. AIR COMPRESSOR ASSEMBLY MAINTENANCE (CONT)

c. Alcohol Evaporator (cont).

STEP	LOCATION	ITEM	ACTION	REMARKS
INSTALLATION				
10	Adapter (3)	a. Nipple (7) b. Elbow (6) c. Connector (5)	Install Install Install	In adapter On nipple (7) On elbow (6)
11	Air compressor	a. New gasket (4) b. Adapter (3) c. Air strainer d. Tube (2) e. Nut (1)	Position Position Install Route Connect and tighten	On air compressor On gasket (4) Para 2-52b Between adapter (3) and body body (13) To connector (5)
12	Alcohol evaporator	a. Tube (2) b. Nut (9) c. Reservoir (8) d. Filler plug (17)	Connect Tighten Install and fill with methanol alcohol Install and tighten	To connector (10)

2-52. AIR COMPRESSOR ASSEMBLY MAINTENANCE (CONT)

d. Air Compressor Governor.

- This task covers:
- a. Removal
 - b. Cleaning
 - c. Inspection
 - d. Installation
 - e. Adjustment

INITIAL SETUP

Tools

No. 1 Common Organizational Maintenance

Tool Kit

- Socket wrench set
- Screwdriver
- Safety glasses

Materials/Parts

- Cleaning solvent Item 1, Appendix C
 - Clean cloths Item 2, Appendix C
 - Gasket FSCM 06853 PN 236577
- line disconnected.

Equipment Condition

Paragraph Condition Description

- Vehicle parked on level surface, engine off and cool, and parking brake applied. Cab tilted 45 degrees.
- 2-41h(l) All air pressure relieved.
- 2-15e Fan clutch air supply line disconnected.
- 2-51b Air compressor governor supply

Personnel Required

Wheel Vehicle Mechanic MOS 63B

KEY

1. Capscrews (2)
2. Lock washers (2)
3. Governor
4. Gasket
5. Rubber cover
6. Nut
7. Adjusting screw

Error! Not a valid filename.

2-52. AIR COMPRESSOR ASSEMBLY MAINTENANCE (CONT)

d. Air Compressor Governor (cont).

STEP	LOCATION	ITEM	ACTION	REMARKS
REMOVAL				
1	Air compressor, rear	a. Two capscrews (1) and lock washers (2) b. Governor (3) c. Gasket (4)	Remove Remove Remove and discard	Support governor (3)

CLEANING

2		a. Governor (3)	Clean	Wipe with clean, dry cloth
---	--	-----------------	-------	----------------------------

WARNING

Dry cleaning solvent (P-D-680), used to clean parts is toxic and flammable. Wear protective goggles and gloves and use only in a well ventilated area. Avoid contact with skin, eyes, and clothes and don't breathe vapors. Do not use near open flame or excessive heat and don't smoke when using it. Failure to do so could cause serious injury. If you become dizzy while using cleaning solvent, get fresh air and medical attention immediately. If contact with skin or clothes is made, flush with large amounts of water. If contact with eyes is made, wash eyes with water and seek medical aid immediately.

		b. Capscrews (1) and lock washers (2)	Clean	Use cleaning solvent P-D-680; dry with clean cloths
--	--	---------------------------------------	-------	---

INSPECTION

3		a. Governor (3)	Inspect	Replace if cracked, inoperative, or otherwise damaged
		b. Capscrews (1) and lock washers (2)	Inspect	Replace if cracked, broken, or threads damaged

2-52. AIR COMPRESSOR ASSEMBLY MAINTENANCE (CONT)

d. Air Compressor Governor (cont).

STEP	LOCATION	ITEM	ACTION	REMARKS
INSTALLATION				
4	Air compressor, rear	a. New gasket (4) b. Governor (3) c. Two lock washers (2) and capscrews (12) d. Governor supply line e. Fan clutch air supply line	Position Position Install and tighten Connect and tighten Connect and tighten	 Para 2-51b Para 2-15e
5	Tractor	a. Cab b. Engine c. Air pressure	Lower Start Check	To normal operating position Build up air pressure Check that AIR PRESS gage indicates within range of 110-120 psi. If gage does not indicate 110-120 psi, perform step 6 below to bring air pressure within proper range
ADJUSTMENT				
6	Governor (3)	a. Rubber cover (5) b. Nut (6) c. Adjusting screw (7) d. Nut (6) e. Rubber cover (5)	Remove Loosen Turn Tighten Install	Turn counterclockwise Don't remove nut (6) To adjust air pressure. Turn clockwise to decrease pressure setting; counterclockwise to increase pressure setting Secures adjustment Turn clockwise to tighten

2-52. AIR COMPRESSOR ASSEMBLY MAINTENANCE (CONT)

e. Air Compressor Assembly.

This task covers: a. Removal c. Inspection
 b. Cleaning d. Installation

INITIAL SETUP

Tools

No. 1 Common Organizational Maintenance Tool Kit

- Socket wrench set
- Combination wrench set
- Puller kit
- Safety glasses

Automotive Mechanic's Tool Kit

- Pliers
- Hammer

Block of wood

Materials/Parts

- Cleaning solvent Item 1, Appendix C
- Clean cloths Item 2, Appendix C
- Tags Item 14, Appendix C
- Gasket, compressor support FSCM 72582 PN 5131939
- Gasket, manifold FSCM 90915 PN 53140297

Equipment Condition

Paragraph Condition Description

- Vehicle parked on level surface, engine off and cool, and parking brake applied. Cab tilted 45 degrees.
- 2-15a(l) Engine cooling system drained.
- 2-41h(1) All air pressure relieved.
- 2-52b Air strainer removed.
- 2-52c Intake adapter and line removed.
- 2-12b Engine oil pan drained.
- 2-15b(2) Coolant filter lines removed.
- 2-51b Air compressor discharge hose disconnected.
- 2-52d Air compressor governor removed.
- 2-15d Drive belts removed.

Personnel Required

Wheel Vehicle Mechanic MOS 63B

STEP	LOCATION	ITEM	ACTION	REMARKS
------	----------	------	--------	---------

REMOVAL

WARNING

Allow engine to cool before beginning these procedures. Hot oil and hot water can cause severe injury. If you are injured, seek medical help immediately.

NOTE

Before disconnecting oil or water hoses, position containers to catch these fluids. Tag all hoses before removal.

1	Engine oil pan, right hand side	a. Connector (1) b. Hose (4) c. Elbow (2)	Loosen Disconnect Remove	From elbow (2)
---	---------------------------------	---	--------------------------------	----------------

2-52. AIR COMPRESSOR ASSEMBLY MAINTENANCE (CONT)

e. Air Compressor Assembly (cont).

KEY

- | | |
|------------------------|----------------------|
| 1. Connector | 32. Nut |
| 2. Elbow | 33. Pulley |
| 3. Connector | 34. Key |
| 4. Hose | 35. Capscrews (2) |
| 5. Connector | 36. Lock washers (2) |
| 6. Hose | 37. Manifold |
| 7. Elbow | 38. Gasket |
| 8. Connector | |
| 9. Hose | |
| 10. Elbow | |
| 11. Capscrews (2) | |
| 12. Lock washers (2) | |
| 13. Washers (2) | |
| 14. Capscrews (2) | |
| 15. Bracket assembly | |
| 16. Capscrew | |
| 17. Lock washer | |
| 18. Nuts (5) | |
| 19. Lock washers (5) | |
| 20. Capscrews (5) | |
| 21. Compressor | |
| 22. Gasket | |
| 23. Capscrew | |
| 24. Lock washer | |
| 25. Capscrew | |
| 26. Lock washer | |
| 27. Capscrew | |
| 28. Lock washer | |
| 29. Compressor support | |
| 30. Shims (AR) | |
| 31. Cotter pin | |

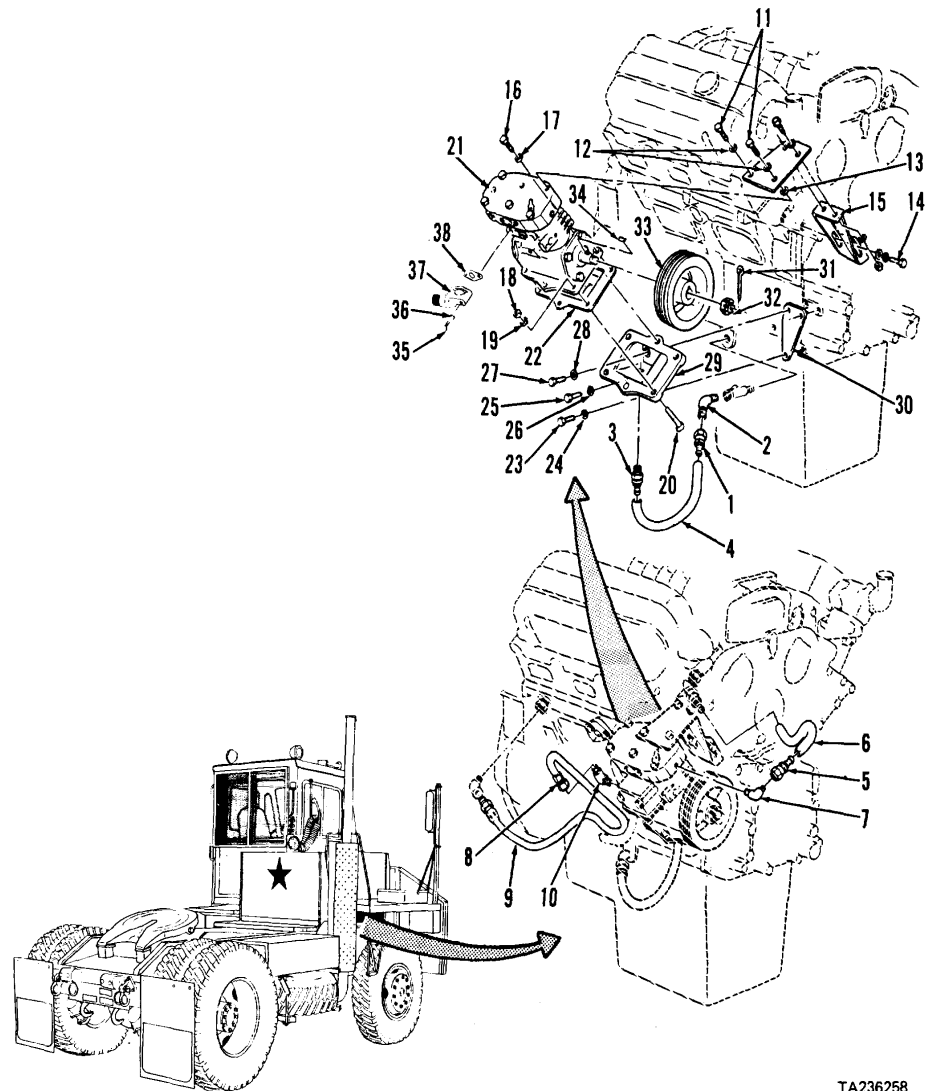

TA236258

2-52. AIR COMPRESSOR ASSEMBLY MAINTENANCE (CONT)

e. Air Compressor Assembly (cont).

STEP	LOCATION	ITEM	ACTION	REMARKS
REMOVAL (cont)				
1 (cont)		d. Connector (3) e. Hose (4)	Loosen Disconnect and remove	From compressor mounting
2	Compressor (21)	a. Connector (5) b. Hose (6) c. Elbow (7) d. Connector (8) e. Hose (9) f. Elbow (10)	Loosen Disconnect Remove Loosen Disconnect Remove	
3	Bracket assembly (15)	a. Two capscrews (11), lock washers (12), and washers (13) b. Two capscrews (14) c. Bracket assembly (15) d. Capscrew (14) in raised position	Remove Loosen Raise Tighten	 Lift up and away from compressor head Holds bracket assembly (15)
4	Compressor (21)	a. Capscrew (16) and lock washer (17) b. Five nuts (18), lock washers (19), and capscrews (20) c. Compressor (21) and gasket (22)	Remove Remove Remove	 Discard gasket (22)
5	Compressor support (29)	a. Capscrew (23) and lock washer (24) b. Capscrew (25) and lock washer (26)	Remove Remove	

2-52. AIR COMPRESSOR ASSEMBLY MAINTENANCE (CONT)

e. Air Compressor Assembly (cont).

STEP	LOCATION	ITEM	ACTION	REMARKS
REMOVAL (cont)				
5 (cont)		c. Capscrew (27), lock washer (28), and compressor support (29)	Remove	
		d. Shims (30)	Remove	Note location and number of shims removed
6	Compressor (21)	a. Compressor (21)	Support	In vise
		b. Cotter pin (31)	Remove	
		c. Nut (32)	Remove	
		d. Pulley (33)	Remove	Use pulley puller
		e. Key (34)	Remove	
		f. Two capscrews (35) and lock washers (36)	Remove	If necessary to remove manifold (37)
		g. Manifold (37) and gasket (38)	Remove discard gasket	If necessary for replacement;
CLEANING				
7		a. Hoses (4, 6, and 9)	Clean	Wipe with clean cloth moist- ened with clean diesel fuel

WARNING

Dry cleaning solvent (P-D-680), used to clean parts is toxic and flammable. Wear protective goggles and gloves and use only in a well ventilated area. Avoid contact with skin, eyes, and clothes and don't breathe vapors. Do not use near open flame or excessive heat and don't smoke when using it. Failure to do so could cause serious injury. If you become dizzy while using cleaning solvent, get fresh air and medical attention immediately. If contact with skin or clothes is made, flush with large amounts of water. If contact with eyes is made, wash eyes with water and seek medical aid immediately.

Compressed air must not exceed 30 psi. Wear safety glasses when drying parts with compressed air. Failure to do so could cause serious injury to eyes and possible blindness. If you hurt your eyes or if a foreign object is blown into your eyes, seek medical attention immediately.

2-52. AIR COMPRESSOR ASSEMBLY MAINTENANCE (CONT)

e. Air Compressor Assembly (cont).

STEP	LOCATION	ITEM	ACTION	REMARKS
CLEANING (cont)				
7 (cont)		b. All remaining parts	Clean	Use cleaning solvent P-D-680; dry with compressed air
INSPECTION				
8		a. Hoses (4, 6, and 9)	Inspect	Replace if cracked, split, or holes are apparent
		b. Compressor support (29)	Inspect	Replace if cracked or distorted
		c. Shims (30)	Inspect	Replace if cracked, broken, or distorted
		d. Pulley (33)	Inspect	Replace if cracked, broken, or otherwise damaged
		e. All other parts	Inspect	Replace if cracked, broken, or threads damaged
INSTALLATION				
9	Compressor (21)	a. Compressor (21)	Support	In vise
		b. Key (34)	Install	
		c. Pulley (33)	Install	Use block of wood and hammer
		d. Nut (32)	Install	Tighten to 100 pounds foot torque

CAUTION

Do not back off nut (32) to align holes for installation of cotter pin (31). If necessary, tighten nut (32) clockwise to align holes.

		e. Cotter pin (31)	Install and spread	
		f. Manifold (37) with new gasket (38)	Position	If removed
		g. Two capscrews (35) and lock washers (36)	Install and tighten	
10	Compressor support (29)	a. Shims (30) and compressor support (29)	Position	

2-52. AIR COMPRESSOR ASSEMBLY MAINTENANCE (CONT)

e. Air Compressor Assembly (cont).

STEP	LOCATION	ITEM	ACTION	REMARKS
INSTALLATION (cont)				
10 (cont)		b. Lock washer (28) and cap-screw (27)	Install and tighten	
		c. Lock washer (26) and cap-screw (25)	Install and tighten	
		d. Lock washer (24) and cap-screw (23)	Install and tighten	
11	Compressor (21)	a. New gasket (22) and compressor (21)	Position	
		b. Five capscrews (20), lock washers (19), and nuts (18)	Install torque	Tighten to 38-45 pounds foot
		c. Lock washer (17) and cap-screw (16)	Install and tighten	
12	Bracket assembly (15)	a. Two capscrews (14)	Loosen	Allows bracket assembly (15) freedom to move
		b. Bracket assembly (15)	Move	Slide downward into position
		c. Two washers (13), lock washers (12), and capscrews (11)	Install and tighten	
		d. Two capscrews (14)	Tighten	
13	Compressor (21)	a. Elbow (10)	Install	
		b. Hose (9)	Connect	
		c. Connector (8)	Tighten	
		d. Elbow (7)	Install	
		e. Hose (6)	Connect	
		f. Connector (5)	Tighten	
14	Engine oil pan, right hand side	a. Hose (4)	Connect	
		b. Connector (3)	Tighten	
		c. Elbow (2)	Install and tighten	
		d. Connector (1)	Tighten	

2-52. AIR COMPRESSOR ASSEMBLY MAINTENANCE (CONT)

e. Air Compressor Assembly (cont).

STEP	LOCATION	ITEM	ACTION	REMARKS
INSTALLATION (cont)				
15	Engine, right hand side	a. Coolant filter lines	Install	Para 2-15b(2)
		b. Air compressor governor	Install	Para 2-52d
		c. Compressor dis- charge hose	Connect	To manifold (37); para 2-51b
		d. Drive belts	Install and adjust	Para 2-15d
		e. Intake adapter and line	Install	Para 2-52c
		f. Air strainer	Install	Para 2-52b
		g. Engine cooling system	Fill	Para 2-15a(1)
		h. Engine oil pan	Fill	Para 2-12b
16	Tractor	a. Cab	Lower	To normal operating position
		b. Engine	Start	Build up air pressure
		c. Air pressure	Check	Para 2-52d
17	Engine, right side, front	All connections	Inspect	For oil or water leaks; tighten connections as necessary

2-53. TRAILER BRAKE LINES AND COUPLINGS

a. Trailer Brake Lines and Couplings.

- This task covers:
- a. Removal
 - b. Cleaning
 - c. Inspection
 - d. Repair
 - e. Installation

INITIAL SETUP

Tools

No. 1 Common Organizational Maintenance

Tool Kit

- Socket wrench set
- Fine tooth hacksaw
- Scratch wire brush
- Combination wrench set
- Screwdriver
- Safety glasses

Materials/Parts

Cleaning

- solvent Item 1, Appendix C
- Clean cloths Item 2, Appendix C
- Tags Item 14, Appendix C
- Teflon tape Item 43, Appendix C
- Tie straps FSCM 96906 PN MS3667-2-9

Personnel Required

Wheel Vehicle Mechanic MOS 63B

Equipment Condition

Paragraph Condition Description

- Vehicle parked on level surface, engine off, and parking brake applied.
- 2-41h(1) All air pressure relieved.
- 2-65d Heat shield removed.
- 2-32f(2) Trailer hand brake stop light switch removed.

STEP	LOCATION	ITEM	ACTION	REMARKS
------	----------	------	--------	---------

REMOVAL

NOTE

Tag all hoses and tubing before removal. Cut, remove, and discard all tie straps and remove all clamps as they are encountered. Note locations of tie straps, and position of tees and elbows, to aid installation.

1	Trailer hand brake control valve	a. Connector (61)	Loosen nut	From connector (61)
		b. Tubing (60) with nut	Disconnect	
		c. Connector (61)	Remove	From trailer hand brake control valve
		d. Connector (62)	Loosen nut	From connector (62)
		e. Tubing (34) with nut	Disconnect	
		f. Connector (62)	Remove	

2-53. TRAILER BRAKE LINES AND COUPLINGS (CONT)

- a. Trailer Brake Lines and Couplings (cont).

Error! Not a valid filename.

2-628

2-53. TRAILER BRAKE LINES AND COUPLINGS (CONT)

a. Trailer Brake Lines and Couplings (cont).

KEY

- | | | |
|--------------------------|---------------------------|----------------------|
| 1. Fitting | 24. Connector | 47. Bulkhead fitting |
| 2. Hose | 25. Tubing (BLU) | 48. Plug |
| 3. Bulkhead fittings (2) | 26. Elbow | 49. Fitting |
| 4. Tubing (RED) | 27. Connector | 50. Elbow |
| 5. Elbow | 28. Elbow | 51. Connector |
| 6. Tee | 29. Connector | 52. Bushing |
| 7. Elbow | 30. Tubing assembly (RED) | 53. Bushing |
| 8. Connector | 31. Coupling | 54. Coupling |
| 9. Rose | 32. Tubing assembly (BLU) | 55. Swivel |
| 10. Bulkhead fitting | 33. Coupling | 56. Hose |
| 11. Swivel | 34. Tubing (BLK) | 57. Connector |
| 12. Elbow | 35. Elbow | 58. Elbow |
| 13. Bushing | 36. Tee | 59. Bushing |
| 14. Bulkhead fitting | 37. Tubing (BLU) | 60. Tubing (BLU) |
| 15. Elbow | 38. Elbow | 61. Connector |
| 16. Fitting | 39. Connector | 62. Connector |
| 17. Tubing (RED) | 40. Tubing (BLU) | 63. Tubing |
| 18. Tee | 41. Connector | 64. Elbow |
| 19. Connector | 42. Tubing (RED) | 65. Tee |
| 20. Tubing | 43. Connector | 66. Elbow |
| 21. Swivel | 44. Connector | 67. Elbow |
| 22. Elbow | 45. Bulkhead fitting | 68. Connector |
| 23. Bulkhead fitting | 46. Plug | |

STEP	LOCATION	ITEM	ACTION	REMARKS
------	----------	------	--------	---------

REMOVAL (cont)

2	Cab firewall, inside	a. Tee (36)	Loosen nut	
		b. Tubing (34) with nuts	a. Disconnect	From tee (36)
			b. Remove	From tractor
		c. Tee (6)	Loosen nut	
		d. Tubing (60) with nuts	a. Disconnect	From tee (6)
			b. Remove	From tractor
3	Cab tilt pump	e. Tee	Disconnect	Para 2-87b
		f. Tees (6 and 36)	Remove	From bulkhead fittings (3)
3	Cab tilt pump	Cab	Tilt 45 degrees	
4	Frame, left hand side	a. Swivel (21) with hose (2)	Disconnect	From elbow (22)
		b. Elbow (22)	Remove	
		c. Swivel (11) with hose (9)	Disconnect	From connector (51)

2-53. TRAILER BRAKE LINES AND COUPLINGS (CONT)

a. Trailer Brake Lines and Couplings (cont).

STEP	LOCATION	ITEM	ACTION	REMARKS
REMOVAL (cont)				
4 (cont)		d. Connector (51), elbow (12), and bushing (13)	Remove	
5	Brake treadle, underside	Fitting (1) with hose (2)	a. Disconnect b. Remove	From brake treadle valve From tractor
6	Air control valve, underside	a. Elbow (5) b. Tubing (4) with nut c. Elbow (5) d. Elbow (64) e. Tubing (63) with nuts f. Elbow (64) g. Air tubing h. Tee (65)	Loosen nut Disconnect Remove Loosen nut Disconnect Remove Disconnect Remove	From elbow (5) From air control valve From elbow (64) From tee (65) From tee (65); para 2-72 From air control valve
7	Cab deck bulkhead	a. Elbow (7) b. Tubing (4) with nut c. Elbow (7) d. Conffector (8) with hose (9) e. Bulkhead fitting (10)	Loosen nut Disconnect Remove a. Disconnect b. Remove Remove	From elbow (7) From bulkhead fitting (10) From bulkhead fitting (10) From tractor Remove nut and pull fitting from cab deck bulkhead
8	Frame, left hand side	a. Fitting (16) b. Tubing (20) with nut c. Connector (19) d. Tubing (17) with nut e. Connector (19), fitting (16), and tee (18) f. Elbow (15) g. Bulkhead fitting (14) h. Elbow (26) i. Tubing (25) with nut	Loosen nut Disconnect Loosen nut Disconnect Remove Remove Remove Loosen nut Disconnect	From fitting (16) From connector (19) From bulkhead fitting (14) Remove nut and pull fitting from bulkhead From elbow (26)

2-53. TRAILER BRAKE LINES AND COUPLINGS (CONT)

a. Trailer Brake Lines and-Couplings (cont).

STEP	LOCATION	ITEM	ACTION	REMARKS
REMOVAL (cont)				
8 (cont)		j. Elbow (26)	Remove	From bulkhead fitting (23)
		k. Bulkhead fitting (23)	Remove	Remove nut and pull fitting from bulkhead
9	Rear cab guard	a. Elbow (28)	Loosen nut	
		b. Tubing (25) with nuts	a. Disconnect	From elbow (28)
		c. Elbow (28)	b. Remove	From tractor
		d. Coupling (54)	Remove	From coupling (54)
		e. Swivel (55) with hose (56)	Remove	From double check valve
		f. Connector (57) and elbow (58)	Disconnect	
		g. Bushing (59)	Remove	From double check valve
		h. Connector (29)	Loosen nut	
		i. Tubing (20) with nuts	a. Disconnect	From connector (29)
		j. Connector (29)	b. Remove	From tractor
		k. Tubing assembly (30)	Remove	
		l. Connector (24)	Disconnect	From connector (24)
		m. Tubing assembly (30)	Remove	From tractor protection valve
		n. Bushing (52)	a. Disconnect	From bushing (52)
		o. Coupling (31)	b. Remove	From tractor
		p. Tubing assembly (32)	Remove	From coupling (31)
		q. Connector (27)	Remove	From hose tender
		r. Tubing assembly (32)	Disconnect	From connector (27)
		s. Bushing (53)	Remove	From tractor protection valve
		t. Coupling (33)	a. Disconnect	From bushing (53)
			b. Remove	From tractor
			Remove	From coupling (33)
			Remove	From hose tender
10	Cab firewall, outside	a. Connector (68) with hose (56)	a. Disconnect	From elbow (67)
		b. Elbow (67)	b. Remove	From tractor
		c. Elbow (66)	Remove	From bulkhead fitting (3)
		d. Tubing (63) with nuts	Loosen nut	
		e. Elbow (66)	a. Disconnect	From elbow (63)
		f. Two bulkhead fittings (3)	b. Remove	From tractor
			Remove	
			Remove	Have assistant remove nuts from other side and pull fittings from cab firewall

2-53. TRAILER BRAKE LINES AND COUPLINGS (CONT)

a. Trailer Brake Lines and Couplings (cont).

STEP	LOCATION	ITEM	ACTION	REMARKS
REMOVAL (cont)				
11	Rear frame	a. Elbow (35)	Loosen nut	
		b. Tubing (17) with nuts	a. Disconnect b. Remove	From elbow (35) From tractor
		c. Elbow (35)	Remove	From tractor protection valve
		d. Elbow (38)	Loosen nut	
		e. Tubing (37) with nut	Disconnect	From elbow (38)
		f. Elbow (38)	Remove	From tractor protection valve
		g. Connector (39)	Loosen nut	
		h. Tubing (40) with nut	Disconnect	From connector (39)
		i. Connector (41)	Loosen nut	
		j. Tubing (42)	Disconnect	From connector (41)
		k. Two connectors (39 and 41)	Remove	From tractor protection valve
		l. Connector (43)	Loosen nut	
		m. Tubing (42) with nuts	a. Disconnect b. Remove	From connector (43) From tractor
		n. Connector (44)	Loosen nut	
		o. Tubing (40) with nuts	a. Disconnect b. Remove	From connector (44) From tractor
		p. Two connectors (43 and 44)	Remove	From bulkhead fittings (45 and 47)
		q. Plug (46)	Remove	From bulkhead fitting (45)
		r. Bulkhead fitting (45)	Remove	Remove nut and pull fitting from bulkhead
		s. Plug (48)	Remove	From bulkhead fitting (47)
		t. Bulkhead fitting (47)	Remove	Remove nut and pull fitting from bulkhead
		u. Fitting (49)	Loosen nut	
		v. Tubing (37) with nuts	a. Disconnect b. Remove	From fitting (49) From tractor
		w. Fitting (49)	Remove	From elbow (50)
		x. Elbow (50)	Remove	From tee
CLEANING				
12		a. Tubing (4, 17, 20, 25, 30, 32, 34, 37, 40, 42, 60, and 63) and hoses (2, 9, and 56)	Clean	Wipe with a clean cloth moistened with water

2-53. TRAILER BRAKE LINES AND COUPLINGS (CONT)

a. Trailer Brake Lines and Couplings (cont).

STEP	LOCATION	ITEM	ACTION	REMARKS
------	----------	------	--------	---------

CLEANING (cont)
12
(cont)

WARNING

Dry cleaning solvent (P-D-680), used to clean parts is toxic and flammable. Wear protective goggles and gloves and use only in a well ventilated area. Avoid contact with skin, eyes, and clothes and don't breathe vapors. Do not use near open flame or excessive heat and don't smoke when using it. Failure to do so could cause serious injury. If you become dizzy while using cleaning solvent, get fresh air and medical attention immediately. If contact with skin or clothes is made, flush with large amounts of water. If contact with eyes is made, wash eyes with water and seek medical aid immediately.

Compressed air must not exceed 30 psi. Wear safety glasses when drying parts with compressed air. Failure to do so could cause serious injury to eyes and possible blindness. If you hurt your eyes or if a foreign object is blown into your eyes, seek medical attention immediately.

		b. All other parts	Clean	Use cleaning solvent P-D-680; dry with compressed air
--	--	--------------------	-------	---

INSPECTION

13	a.	Tubing (4, 17, 20, 25, 30, 32, 34, 37, 40, 42, 60, and 63) and hoses (2, 9, and 56)	Inspect	Replace if cracked, split, chafed, or deteriorated. Refer to step 14 below for hose replacement; refer to step 15 below for tubing replacement
	b.	All other parts	Inspect	Replace if cracked, worn, distorted, or threads damaged. Refer to step 14 below for replacement of hose connectors; refer to step 15 below for replacement of tubing connectors

2-53. TRAILER BRAKE LINES AND COUPLINGS (CONT)

a. Trailer Brake Lines and Couplings (cont).

STEP	LOCATION	ITEM	ACTION	REMARKS
------	----------	------	--------	---------

REPAIR

14	Hoses	a. Connector b. Nut	Turn counterclockwise out of nut and hose Turn clockwise and remove from hose	
----	-------	------------------------	--	--

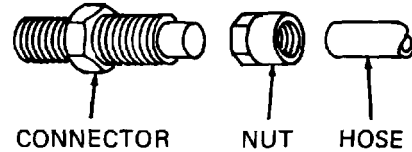

TA236184

NOTE

Repeat steps 14a and 14b above to disassemble remaining connectors from hoses.

WARNING

Dry cleaning solvent (P-D-680), used to clean parts is toxic and flammable. Wear protective goggles and gloves and use only in a well ventilated area. Avoid contact with skin, eyes, and clothes and don't breathe vapors. Do not use near open flame or excessive heat and don't smoke when using it. Failure to do so could cause serious injury. If you become dizzy while using cleaning solvent, get fresh air and medical attention immediately. If contact with skin or clothes is made, flush with large amounts of water. If contact with eyes is made, wash eyes with water and seek medical aid immediately.

		c. Connector and nut	Clean	Use cleaning solvent P-D-680; allow to air dry. Use wire brush to remove all hose residue from connector and nut
		d. Hose	Cut to proper length	Use new hose; use old hose to determine proper length required. Cut hose square using fine tooth hacksaw
		e. Nut	Screw counterclockwise onto hose until hose bottoms	
		f. Connector	Screw clockwise into nut and hose and tighten securely	

2-53. TRAILER BRAKE LINES AND COUPLINGS (CONT)

a. Trailer Brake Lines and Couplings (cont).

STEP	LOCATION	ITEM	ACTION	REMARKS
------	----------	------	--------	---------

REPAIR (cont)

14
(cont)

NOTE

Repeat steps 14e and 14f above to install remaining connectors on hoses.

15	Tubing	a. Tubing	Cut	Between nut and sleeve
		b. Nut	Remove	Slide from tubing
		c. Insert	Remove, if necessary	Pull from tubing only if separated from fitting
		d. Sleeve	Discard	

Error! Not a valid filename.

NOTE

Repeat steps 15a thru 15d above to disassemble remaining fittings from tubing.

e. Tubing	Cut to proper length	Use new tubing; use old tubing to determine proper length
f. Nut	Position	Slide onto tubing, threaded end out
g. New sleeve	Position	Slide onto tubing
h. Insert	Install, if necessary	Push into tubing only if separated from fitting

WARNING

Tubing must be installed over insert for secure connection. Installation of fitting without insert will allow air pressure to force tubing from fitting, resulting in dangerous loss of air pressure.

2-53. TRAILER BRAKE LINES AND COUPLINGS (CONT)

a. Trailer Brake Lines and Couplings (cont).

STEP	LOCATION	ITEM	ACTION	REMARKS
REPAIR (cont)				
15 (cont)		i. Tubing	Install	Push onto insert until seated inside fitting
		j. Nut	Tighten	Hand tight only; prevents loss of sleeve before installation

NOTE

Repeat steps 15e thru 15j above to install remaining fittings on tubing.

INSTALLATION**NOTE**

In the following steps, wrap male pipe threads with Teflon tape before installation. Tighten tees and elbows to positions noted during removal. Secure hoses and tubing with clamps and new tie straps at locations noted during removal.

16	Frame, right hand side, rear	a. Elbow (50)	Install	
		b. Fitting (49)	Install	
		c. Tubing (37) with nuts	a. Route b. Connect c. Tighten nut	To fitting (49)
17	Rear frame	a. Bulkhead fitting (47)	Install	
		b. Bulkhead fitting (45)	Install	
		c. Plug (48)	Install	
		d. Plug (46)	Install	
		e. Connector (44)	Install	
		f. Tubing (40) with nuts	a. Route b. Connect c. Tighten nut	To connector (44)
		g. Connector (43)	Install	
		h. Tubing (42) with nuts	a. Route b. Connect c. Tighten nut	To connector (43)
		i. Connector (41)	Install	
		j. Tubing (42) with nut	a. Connect b. Tighten nut	To connector (41)

2-53. TRAILER BRAKE LINES AND COUPLINGS (CONT)

a. Trailer Brake Lines and Couplings (cont).

STEP	LOCATION	ITEM	ACTION	REMARKS
INSTALLATION (cont)				
17 (cont)		k. Connector (39)	Install	
		l. Tubing (40) with nut	a. Connect	To connector (39)
		m. Elbow (38)	b. Tighten nut	
		n. Tubing (37) with nut	Install	
		o. Elbow (35)	a. Connect	To elbow (38)
		p. Tubing (17) with nuts	b. Tighten nut	
			Install	
			a. Route	
			b. Connect	
			c. Tighten nut	
18	Cab firewall, outside	a. Two bulkhead fittings(3)	Install	Have assistant hold nut while tightening
		b. Elbow (66)	Install	
		c. Tubing (63) with nuts	a. Route	
			b. Connect	To elbow (66)
			c. Tighten nut	
		d. Elbow (67)	Install	
		e. Connector (68) with hose (56)	a. Route	
			b. Connect	To elbow (67)
			c. Tighten nut	
19	Rear cab guard	a. Bushing (59)	Install	In double check valve
		b. Elbow (58) and connector (57)	Install	
		c. Swivel (55) with hose (56)	Connect	To connector (57)
		d. Coupling (54)	Install	In double check valve
		e. Elbow (28)	Install	
		f. Tubing (25) with nuts	a. Route	
			b. Connect	To elbow (28)
		c. Tighten nut		
		g. Coupling (33)	Connect	To hose tender
		h. Bushing (53)	Install	In coupling (33)
		i. Tubing assembly (32)	a. Route	
			b. Connect	To bushing (53)
		j. Coupling (31)	Connect	To hose tender
		k. Bushing (52)	Install	In coupling (31)
		l. Tubing assembly (30)	a. Route	
			b. Connect	To bushing (52)
		m. Two connectors (24 and 27)	Install	In tractor protection valve
		n. Tubing assembly Connect (32)	To connector (27)	

2-53. TRAILER BRAKE LINES AND COUPLINGS (CONT)

a. Trailer Brake Lines and Couplings (cont).

STEP	LOCATION	ITEM	ACTION	REMARKS
INSTALLATION (cont)				
19 (cont)		o. Tubing assembly (30)	Connect	To connector (24)
		p. Connector (29)	Install	In tractor protection valve
		q. Tubing (20) with nuts	a. Route b. Connect	To connector (29)
20	Frame, left hand side	c. Tighten nut		
		a. Bulkhead fitting (23)	Install	
		b. Elbow (26)	Install	
		c. Tubing (25) with nuts	a. Route b. Connect c. Tighten nut	To elbow (26)
		d. Bulkhead fitting (14)	Install	
		e. Elbow (15)	Install	
		f. Tee (18)	Install	
		g. Fitting (16)	Install	
		h. Tubing (20) with nut	a. Connect b. Tighten nut	To fitting (16)
		i. Connector (19)	Install	
		j. Tubing (17) with nut	a. Connect b. Tighten nut	To connector (19)
21	Cab deck bulkhead	a. Bulkhead fitting (10)	Install	
		b. Connector (8) with lose (9)	a. Route b. Connect	To bulkhead fitting (10)
		c. Elbow (7)	Install	
		d. Tubing (4) with nuts	a. Route b. Connect	To elbow (7)
		c. Tighten nut		
22	Air control valve, underside	a. Elbow (5)	Install	To elbow (5)
		b. Tubing (4) with nuts	a. Connect nut b. Tighten nut	To elbow (5)
		c. Tee (65)	Install	
		d. Air tubing	Connect	To tee (65); para 2-72
		e. Elbow (64)	Install	
		f. Tubing (63) with nuts	a. Connect b. Tighten nut	To elbow (64)

2-53. TRAILER BRAKE LINES AND COUPLINGS (CONT)

- a. Trailer Brake Lines and Couplings (cont).

STEP	LOCATION	ITEM	ACTION	REMARKS
INSTALLATION (cont)				
23	Brake treadle, underside	Fitting (1) with hose (2)	a. Route b. Connect	
24	Frame, left hand side	a. Bushing (13), elbow (12), and connector (51) b. Swivel (11) with hose (9) c. Elbow (22) d. Connector (21) with hose (2) e. Heat shield	Install Connect Install Connect Install	 Para 2-65d
25	Cab tilt pump	Cab	Lower	To normal operating position
26	Cab deck bulkhead	a. Tee (36) b. Tee c. Tubing (34) with nuts d. Tee (6) e. Tubing (60) with nuts	Install Install a. Route b. Connect c. Tighten nut Install a. Route b. Connect c. Tighten nut	Para 2-87b To tee (36)
27	Trailer hand brake control valve	a. Two connectors (61 and 62) b. Tubing (60) with nut c. Tubing (34) with nut	Install a. Connect b. Tighten nut a. Connect b. Tighten nut	In trailer hand brake control valve To connector (61) To connector (62)
28	Cab	Trailer hand brake stop light switch	Install	Para 2-32f(2)
29	Tractor	Air pressure	Restore	Para 2-41h(1)
30	Lines and couplings	All connections	Inspect for leaks	Apply soapy solution around connections and check for leaks; tighten or replace leaky connections

2-53. TRAILER BRAKE LINES AND COUPLINGS (CONT)

b. Hose Tender.

- This task covers:**
- | | |
|----------------|-----------------|
| a. Removal | d. Inspection |
| b. Disassembly | e. Reassembly |
| c. Cleaning | f. Installation |

INITIAL SETUP

Tools

- No. 1 Common Organizational Maintenance Tool Kit
 Socket wrench set
 Combination wrench set
 Screwdriver
 Safety glasses

Equipment Condition

- | Paragraph | Condition Description |
|-----------|---|
| 2-53a | Vehicle parked on level surface, engine off, and parking brake applied.
Trailer brake air lines disconnected from hose tender couplings. |

Materials/Parts

- | | |
|------------------|--------------------|
| Cleaning solvent | Item 1, Appendix C |
| Clean cloths | Item 2, Appendix C |

Personnel Required

Wheel Vehicle Mechanic MOS 63B

KEY

1. Nut
2. Lock washer
3. Washer
4. Hose tender
5. Locknuts (4)
6. Screws (4)
7. Brackets (2)
8. Nut
9. J-bolt

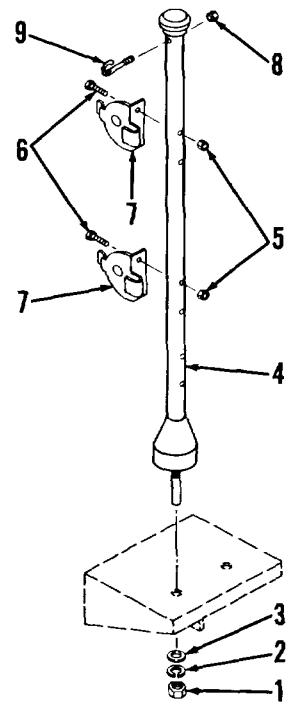
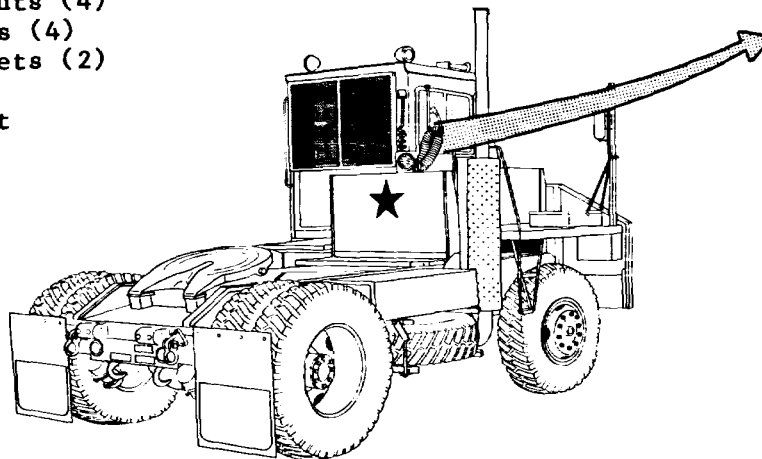

TA236221

2-53. TRAILER BRAKE LINES AND COUPLINGS (CONT)

b. Hose Tender.

STEP	LOCATION	ITEM	ACTION	REMARKS
------	----------	------	--------	---------

REMOVAL

1	Rear cab guard and washer (3)	a. Nut (1), lock washer (2),	Remove	Support hose tender (4)
		b. Hose tender (4)	Remove	Lift from rear cab guard

DISASSEMBLY

2	Hose tender (4)	a. Four nuts (5) and screws (6)	Remove	Support brackets (7)
		b. Two brackets (7)	Remove	
		c. Nut (8) and J-bolt (9)	Remove	

CLEANING**WARNING**

Dry cleaning solvent (P-D-680), used to clean parts is toxic and flammable. Wear protective goggles and gloves and use only in a well ventilated area. Avoid contact with skin, eyes, and clothes and don't breathe vapors. Do not use near open flame or excessive heat and don't smoke when using it. Failure to do so could cause serious injury. If you become dizzy while using cleaning solvent, get fresh air and medical attention immediately. If contact with skin or clothes is made, flush with large amounts of water. If contact with eyes is made, wash eyes with water and seek medical aid immediately.

Compressed air must not exceed 30 psi. Wear safety glasses when drying parts with compressed air. Failure to do so could cause serious injury to eyes and possible blindness. If you hurt your eyes or if a foreign object is blown into your eyes, seek medical attention immediately.

3	All parts	Clean	Use cleaning solvent P-D-680; dry using compressed air or clean cloths
---	-----------	-------	--

2-641

2-53. TRAILER BRAKE LINES AND COUPLINGS (CONT)

- b. Hose Tender.

STEP	LOCATION	ITEM	ACTION	REMARKS
INSPECTION				
4		a. Hose tender (4)	Inspect	Replace if bent, distorted, dented, or cracked
		b. All other parts	Inspect	Replace if cracked, bent, distorted, or threads damaged
REASSEMBLY				
5	Hose tender (4)	a. J-bolt (9) and nut (8)	Install and tighten	
		b. Two brackets (7)	Position	
		c. Four screws (6) and nuts	Install and tighten	
INSTALLATION				
6	Rear cab guard	a. Hose tender (4)	Position	
		b. Washer (3), lock washer (2), and nut (1)	Install and tighten	
7	Trailer brake air lines	Air lines couplings	Connect	To hose tender couplings (prevents entry of dirt)

Section VIII. WHEELS AND STEERING SYSTEM MAINTENANCE

This section contains the information you will need to maintain the:

- Wheels and Tires
- Steering System

It gives you information on how to troubleshoot problems and repair or replace the components that are within the scope of organizational maintenance.

	Para
Troubleshooting Symptom Index	2-54
Wheels and Tires Troubleshooting	2-55
Steering System Troubleshooting	2-56
Wheels and Tires Maintenance	2-57
Steering System Maintenance	2-58
Steering Wheel.....	2-58a
Hydraulic Steering Lines & Fittings	2-58b
Power Steering Reservoir	2-58c

2-54. TROUBLESHOOTING SYMPTOM INDEX

	Para/Malfunction	Page
WHEELS AND TIRES		
Tire wearing unevenly	2-55/1	2-644
Noisy or bumping sound while traveling	2-55/2	2-644
STEERING SYSTEM		
Tractor wanders over road	2-56/1	2-646
No recovery	2-56/2	2-646
Shimmy.....	2-56/3	2-646
High steering effort in both directions.....	2-56/4	2-647
Lost motion at steering wheel.....	2-56/5	2-647
Power steering pump making noise	2-56/6	2-648

2-55. WHEELS AND TIRES TROUBLESHOOTING

MALFUNCTION**TEST OR INSPECTION****CORRECTIVE ACTION****1. TIRE WEARING UNEVENLY**

Step 1. Place wood blocks at each wheel to prevent tractor from moving.

Raise one axle and wheels off ground.

Release tractor parking brake.

Place jack stands under tractor at axle ends.

Rotate wheel by hand; there should be a slight drag on wheel.

Repeat above for remaining wheel and axle.

a. If there is excessive drag on wheels, adjust brakes (para 2-50a for front axle brakes; para 2-51d(2) for rear axle brakes).

b. If there is only a slight drag on wheels, go to step 2 below.

Step 2. With wheel off ground (step 1 above), check wheel bearing adjustment (use pry bar to check for noticeable end play).

a. If there is noticeable end play, adjust wheel bearing (para 2-43b for front axle; para 2-44b for rear axle).

b. If there is no noticeable end play, go to step 3 below.

Step 3. Check that wheel bearing is properly lubricated.

a. If wheel bearing is not properly lubricated, lubricate (para 2-43b for front axle; para 2-44b for rear axle).

b. If wheel bearing is properly lubricated, go to step 4 below.

Step 4. Check wheel bearing for damage (para 2-43b for front axle; para 2-44b for rear axle).

a. If wheel bearing is damaged, replace (para 2-43b for front axle; para 2-44b for rear axle).

b. If wheel bearing is not damaged, notify direct support maintenance.

2. NOISY OR BUMPING SOUND WHILE TRAVELING

Step 1. Check if wheel lug nuts are loose.

a. If lug nuts are loose, tighten to 500-550 pounds foot (para 2-57).

b. If lug nuts are tight, go to step 2 below.

2-55. WHEELS AND TIRES TROUBLESHOOTING

MALFUNCTION**TEST OR INSPECTION****CORRECTIVE ACTION****2. NOISY OR BUMPING SOUND WHILE TRAVELING (Cont)**

Step 2. If sound is coming from front axle, check shock absorbers for cracks, scored rod, or leakage. Check spacers for wear or damage.

- a. If shock absorbers are cracked, leaking fluid, or if rod is scored, replace (para 2-64); if spacers are worn or damaged, replace (para 2-64).
- b. If shock absorbers and spacers are okay, go to step 3 below.

Step 3. If sound is coming from front axle, check rubber block for damage.

- a. If rubber block is damaged or worn, replace (para 2-64).
- b. If rubber block is not damaged or worn, go to step 4 below.

Step 4. Place wood blocks at each wheel to prevent tractor from moving.

Raise one axle and wheels off ground.

Release parking brake; then rotate wheel by hand while listening for a rumbling or grinding sound. Repeat for other axle.

- a. If rumbling or grinding sound is heard, go to step 5 below.
- b. If rumbling or grinding sound is not heard, go to step 6 below.

Step 5. Check front axle hub or rear axle lubrication level.

- a. If level is low, add lubricant (para 2-43a or 2-44a).
- b. If level is not low, go to step 7 below.

Step 6. With wheel off ground (step 4 above), check wheel bearing adjustment (use pry bar to check for noticeable end play).

- a. If there is noticeable end play, adjust wheel bearing (para 2-43b for front axle; para 2-44b for rear axle).
- b. If there is no noticeable end play, go to step 7 below.

Step 7. Check front and rear axle wheel bearings for damage.

- a. If wheel bearing is damaged, replace (para 2-43b for front axle; para 2-44b for rear axle).
- b. If wheel bearing is not damaged, go to step 8 below.

2-55. WHEELS AND TIRES TROUBLESHOOTING (CONT)**MALFUNCTION****TEST OR INSPECTION****CORRECTIVE ACTION****2. NOISY OR BUMPING SOUND WHILE TRAVELING (Cont)**

Step 8. Check front and rear axle brakes for loose, missing, or damaged parts.

- a. If parts are loose, missing, or damaged, replace (para 2-50a for front axle brakes; para 2-50b for rear axle brakes).
- b. If parts are not loose, missing, or damaged, go to step 9 below.

Step 9. Disassemble tire from wheel and check for damage due to foreign material (para 2-57).

- a. Remove foreign material; replace tire if damaged (para 2-57).
- b. If tire is not damaged, notify direct support maintenance.

2-56. STEERING SYSTEM TROUBLESHOOTING**MALFUNCTION****TEST OR INSPECTION****CORRECTIVE ACTION****1. TRACTOR WANDERS OVER ROAD**

Check if air pressure in each tire is 120 psi.

- a. If air pressure is not 120 psi, adjust tire pressure.
- b. If air pressure is 120 psi, notify direct support maintenance.

2. NO RECOVERY

Check if air pressure in each tire is 120 psi.

- a. If air pressure is not 120 psi, adjust tire pressure.
- b. If air pressure is 120 psi, notify direct support maintenance.

3. SHIMMY

Check power steering hoses, lines and fittings for leaks.

- a. If hoses, lines or fittings are leaking, replace (para 2-58b).
- b. If leaks are not seen, refer to para 2-39, Malfunction 2.

2-56. STEERING SYSTEM TROUBLESHOOTING (CONT)**MALFUNCTION****TEST OR INSPECTION****CORRECTIVE ACTION****4. HIGH STEERING EFFORT IN BOTH DIRECTIONS**

- Step 1. Check oil level in power steering reservoir.
- a. If oil level is low, add oil (para 2-58c).
 - b. If oil level is not low, go to step 2 below.
- Step 2. Check if air pressure in front tires is 120 psi.
- a. If air pressure in front tires is not 120 psi, adjust tire pressure.
 - b. If air pressure in front tires is 120 psi, go to step 3 below.
- Step 3. Check power steering system hoses for restrictions (sharp bends, blockage). Remove hoses if necessary (para 2-58b).

WARNING

Compressed air must not exceed 30 psi. Wear safety glasses when using compressed air. Failure to do so could cause serious injury to eyes and possible blindness. If you hurt your eyes or if a foreign object is blown into your eyes, seek medical aid immediately.

- a. If hoses are blocked, use compressed air (30 psi maximum) to remove blockage; if blockage cannot be removed, replace hoses (para 2-58b).
 - b. If hoses are not blocked, go to step 4 below.
- Step 4. Check for clogged power steering reservoir filter element.
- a. If filter element is clogged, replace (para 2-58c).
 - b. If filter element is okay, notify direct support maintenance.

5. LOST MOTION AT STEERING WHEEL

Check if steering wheel is loose on shaft.

- a. If steering wheel is loose, tighten wheel nut (para 2-58a).
- b. If steering wheel is not loose, notify direct support maintenance.

2-56. STEERING SYSTEM TROUBLESHOOTING (CONT)**MALFUNCTION****TEST OR INSPECTION****CORRECTIVE ACTION****6. POWER STEERING PUMP MAKING NOISE**

- Step 1. Check for restriction (sharp bends, blockage) in two hoses connecting power steering reservoir to power steering pump.
Remove hoses if necessary (para 2-58b).

WARNING

Compressed air must not exceed 30 psi. Wear safety glasses when using compressed air. Failure to do so could cause serious injury to eyes and possible blindness. If you hurt your eyes or if a foreign object is blown into your eyes, seek medical aid immediately.

- a. If hoses are blocked, use compressed air (30 psi maximum) to remove blockage; if blockage cannot be removed, replace hoses (para 2-58b).
- b. If hoses are not blocked, go to step 2 below.

- Step 2. Check for clogged power steering reservoir filter element.

- a. If filter element is clogged, replace (para 2-58c).
- b. If filter element is not clogged, notify direct support maintenance.

12-57. WHEELS AND TIRES MAINTENANCE

- This task covers:
- a. Removal
 - b. Dismounting
 - c. Cleaning
 - d. Inspection/Repair
 - e. Mounting
 - f. Installation

INITIAL SETUP

Tools

- No. 1 Common Organizational Maintenance Tool Kit
 - Safety glasses
 - Pneumatic tire valve fishing tool
 - Wire brush
 - Tire pressure gage
 - Tire iron
 - Wheel stud nut socket wrench
 - Torque wrench, 550 pounds foot capacity
 - Chain hoist

Personnel Required

Two Wheel Vehicle Mechanics MOS 63B

Equipment Condition

Paragraph Condition Description

Parked on level surface; parking brake applied; engine off. Wheels blocked (as required). Axle end supported (as required).

Materials/Parts

- Cleaning solvent Item 1, Appendix C
- Clean cloths Item 2, Appendix C
- Detergent Item 27, Appendix C
- Tube repair kit
- Wood blocks

STEP	LOCATION	ITEM	ACTION	REMARKS
------	----------	------	--------	---------

REMOVAL

WARNING

Before performing the following step, be sure that axle end is securely supported by jack stands. Failure to do so could cause chassis to fall on you causing serious injury or death.

NOTE

Step.1 details the removal of the front wheel and tire assembly. Removal of the dual-mounted rear wheels and tires is similar, except that both wheels must be removed to replace the inner wheel and tire.

- | | | | | |
|----|---------------------|--|--|---|
| 1. | Wheel to be removed | <ul style="list-style-type: none"> a. Valve cap (1) b. Valve core (2) c. Ten lug nuts (3) d. Wheel and tire assembly | <ul style="list-style-type: none"> Remove Remove Remove Remove from axle end | <ul style="list-style-type: none"> To deflate tire Use lug nut wrench |
|----|---------------------|--|--|---|

2-57. WHEELS AND TIRES MAINTENANCE (CONT)

KEY

- 1. Valve cap
- 2. Value core
- 3. Lug nuts (10)
- 4. Rim
- 5. Wheel
- 6. Flap
- 7. Tube
- 8. Tire
- 9. Ring

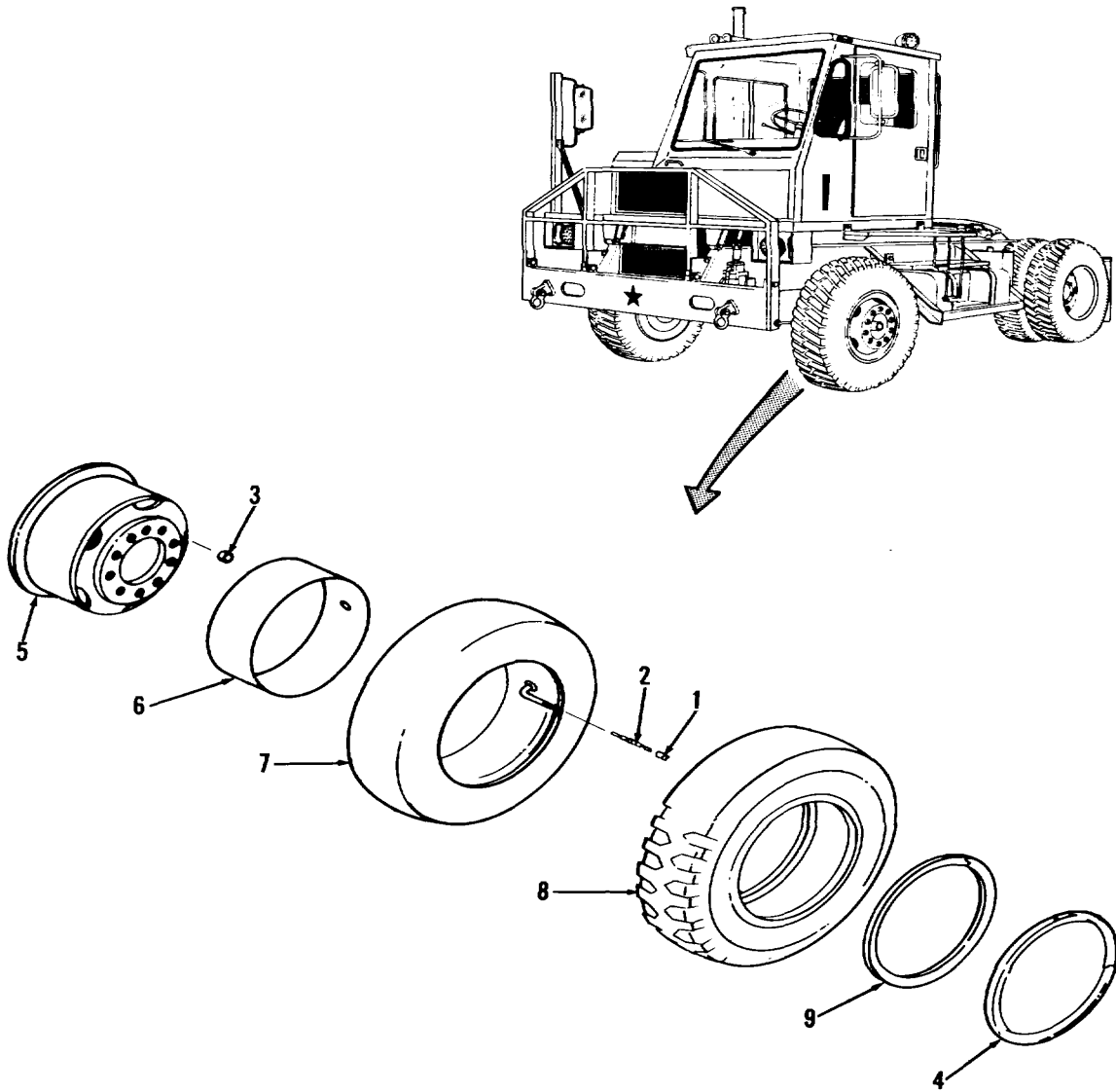

TA236365

2-57. WHEELS AND TIRES MAINTENANCE (CONT)

STEP	LOCATION	ITEM	ACTION	REMARKS
DISMOUNTING				
WARNING				
Be sure tire is deflated and valve core removed before proceeding with dismounting. Failure to do so could cause serious injury due to parts flying off wheel and tire. If you are injured due to not completely deflating tire, obtain medical aid immediately.				
2	Wheel and tire assembly	a. Tire (8)	Break bead	Use tire iron; break top bead loose from wheel (5) flange Turn assembly over and break opposite bead loose from ring (9)
		b. Ring (9)	Depress	Depress enough to clear rim (4)
		c. Rim (4)	Remove	Insert end of tire iron at safety bulge on rim; pry rim out of groove in wheel (5) base
		d. Ring (9)	Remove	
		e. Valve cap (1)	Install	On tube (7) valve
		f. Tube (7) valve	Depress	Use blunt tool and push valve down through valve hole
		g. Valve cap (1)	Remove	
		h. Wheel (5)	Remove	Withdraw evenly out of tire (8)
		i. Flap (6)	Remove	
		j. Tube (7)	Remove	

CLEANING

WARNING

Dry cleaning solvent (P-D-680), used to clean parts is toxic and flammable. Wear protective goggles and gloves and use only in a well ventilated area. Avoid contact with skin, eyes, and clothes and don't breathe vapors. Do not use near open flame or excessive heat and don't smoke when using it. Failure to do so could cause serious injury. If you become dizzy while using cleaning solvent, get fresh air and medical attention immediately. If contact with skin or clothes is made, flush with large amounts of water. If contact with eyes is made, wash eyes with water and seek medical aid immediately.

2-57. WHEELS AND TIRES MAINTENANCE (CONT)

STEP	LOCATION	ITEM	ACTION	REMARKS
CLEANING (cont)				
WARNING				
Compressed air must not exceed 30 psi. Wear safety glasses when drying parts with compressed air. Failure to do so could cause serious injury to eyes and possible blindness. If you hurt your eyes or if a foreign object is blown into your eyes, seek medical attention immediately.				
3	a. Wheel (5)	Clean	Use cleaning solvent P-D-680 and wire brush to remove any rust and corrosion. Dry using compressed air	
	b. Lug nuts (3),	Clean	Use cleaning solvent P-D-680; rim (4), ring dry using compressed air (9), and wheel studs	
	c. Flap (6) and tire (7)	Clean	Use mild detergent solution; rinse with clear water. Dry using compressed air	

INSPECTION/REPAIR

4	a. Lug nuts (3) and studs	Inspect for: cracks breaks distortion damaged threads	Replace as necessary; if vehicle has been operated with one or more broken studs, replace all studs on affected side of vehicle (para 2-43)	
	b. Rim (4) and ring (9)	Inspect for: cracks distortion damage	Replace as necessary	
	c. Wheel (5)	Inspect for: cracks distortion wear elongated bolt holes damage	:Replace as necessary	
	d. Flap (6)	Inspect for: cracks tears deterioration damage	Replace as necessary	

2-57. WHEELS AND TIRES MAINTENANCE (CONT)
--

STEP	LOCATION	ITEM	ACTION	REMARKS
INSPECTION/REPAIR (cont)				
4 (cont)	e. Tube (7)	Inspect for: deterioration holes		Repair leaks/holes using tube repair kit. Replace if deteriorated or beyond economical repair Replace as necessary
	f. Tire (8)	Inspect for: cuts breaks uneven tread wear damage		

MOUNTING**WARNING**

Don't use oil as a lubricant. Oil will cause the rubber to deteriorate over a period of time with possible personal injury resulting.

5	Tire (8)	a. Tube (7) and flap (6)	Install	In tire (8). Lubricate tire beads and flap with soapy water solution or commercial lubricant Start wheel into tire evenly and insert valve through valve hole in wheel Push wheel evenly into tire; then position wheel on blocks to hold wheel up in tire Push down so rim (4) can be Installed Place rim on wheel evenly, and walk rim into position. Be sure rim is firmly and evenly seated
		b. Wheel (5)	a. Install b. Position	
	c. Ring (9)	Install		
	d. Rim (4)	Install		
	e. Valve core (2)	Install		

WARNING

Place tire and wheel assembly in a safety cage before inflating tire. If not properly assembled, inflation may cause the wheel and rim to separate with explosive force causing serious injury or death. If you are injured, obtain medical help immediately.

2-57. WHEELS AND TIRES MAINTENANCE (CONT)
--

STEP	LOCATION	ITEM	ACTION	REMARKS
MOUNTING (cont)				
5 (cont)		f. Tire (8)	a. Inflate b. Lift up-right	To approximately 30 psi Check that beads are properly positioned

WARNING

Don't overinflate tire. Observe caution when inflating tires. Be sure tires are properly seated on rims before inflating. Improperly seated tires can burst with explosive force sufficient to cause death or serious injury. If you are injured while inflating a tire, obtain medical aid immediately.

		g. Valve cap (1)	c. Inflate Install	To 120 psi
--	--	------------------	-----------------------	------------

INSTALLATION

6	Axle end	a. Wheel and tire assembly b. Ten lug nuts (3)	Install Install and tighten	On axle end Tighten to 525 pounds foot torque
7	Tractor Axle end		Lower to ground and remove wheel chocks	

2-654

2-58. STEERING SYSTEM MAINTENANCE

a. Steering Wheel.

This task covers: a. Removal c. Inspection
 b. Cleaning d. Installation

INITIAL SETUP

Tools

- No. 1 Common Organizational Maintenance Tool Kit
 - Socket wrench set
 - Torque wrench
 - Knife
 - Safety glasses
- Automotive Mechanic's Tool Kit
 - Steering wheel puller

Personnel Required

Wheel Vehicle Mechanic MOS 63B

Equipment Condition

Paragraph Condition Description
 Vehicle parked on level surface, engine off, and parking brake applied.
 2-33b Horn button removed.

Materials/Parts

- Cleaning solvent Item 1, Appendix C
- Clean cloths Item 2, Appendix C
- Detergent Item 27, Appendix C
- Masking tape Item 28, Appendix C

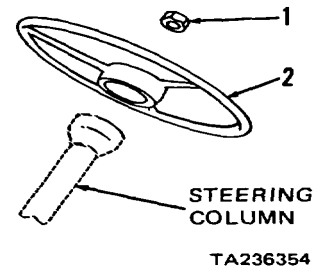

KEY

- 1. Wheel nut
- 2. Steering wheel

STEP	LOCATION	ITEM	ACTION	REMARKS
REMOVAL 1	Steering column	a. Steering wheel (2)	Mark position	Use masking tape; mark positions of steering wheel spokes by taping strips of tape downward from spokes at button ends and onto steering column
		b. Tape applied in step 1a	Slit	
		c. Wheel nut (1)	Remove	Use steering wheel puller
		d. Steering wheel (2)	Remove	

2-655

2-58. STEERING SYSTEM MAINTENANCE (CONT)

a. Steering Wheel (cont).

STEP	LOCATION	ITEM	ACTION	REMARKS
CLEANING				
2	a. Steering wheel (2)	Clean		Wipe with clean cloth moistened with mild detergent solution

WARNING

Dry cleaning solvent (P-D-680), used to clean parts is toxic and flammable. Wear protective goggles and gloves and use only in a well ventilated area. Avoid contact with skin, eyes, and clothes and don't breathe vapors. Do not use near open flame or excessive heat and don't smoke when using it. Failure to do so could cause serious injury. If you become dizzy while using cleaning solvent, get fresh air and medical attention immediately. If contact with skin or clothes is made, flush with large amounts of water. If contact with eyes is made, wash eyes with water and seek medical aid immediately.

Compressed air must not exceed 30 psi. Wear safety glasses when drying parts with compressed air. Failure to do so could cause serious injury to eyes and possible blindness. If you hurt your eyes or if a foreign object is blown into your eyes, seek medical attention immediately.

	b. Wheel nut (1)	Clean	Use cleaning solvent P-D-680; dry thoroughly with compressed air or clean cloths	
INSPECTION				
3	Wheel nut (1) and steering wheel (2)	Inspect		Replace if cracked, broken, distorted, or threads damaged

INSTALLATION

4	Steering column	a. Steering wheel (2)	Install	Align tape on steering wheel base with tape on steering column
		b. Wheel nut (1)	Install	Tighten to 55-65 pounds foot torque
		c. Masking tape	Remove	From steering wheel base and steering column
		d. Horn button	Install	Para 2-33b

2-58. STEERING SYSTEM MAINTENANCE (CONT)

b. Hydraulic Steering Lines and Fittings.

- This task covers:**
- a. Removal
 - b. Cleaning
 - c. Inspection
 - d. Repair
 - e. Installation

INITIAL SETUP

Tools

- No. 1 Common Organizational Maintenance Tool Kit
 - Open end wrench set
 - Fine tooth hacksaw
 - Scratch wire brush
 - Machinist's vise
 - Machinist's steel rule
 - Mandrel assembly tool
 - FSCM 00624 PN 1582-8

- Detergent
- Tie straps
- Item 27, Appendix C
- FSCM 96906 PN MS3667-2-9

Personnel Required

Wheel Vehicle Mechanic MOS 63B

Equipment Condition

Paragraph Condition Description

Materials/Parts

- Cleaning solvent Item 1, Appendix C
- Clean cloths Item 2, Appendix C
- Hydraulic oil Item 22, Appendix C

2-58c Parked on level surface; parking brake applied; engine off. Cab tilted 45 degrees. Hydraulic oil drained from power steering reservoir.

REMOVAL

- | | | | | |
|---|---------------------|---------------------------------|--------------------------------|--------------------------------------|
| 1 | Steering gear | a. Connector (1) | Loosen, disconnect, and cap | Cap prevents entry of foreign matter |
| | | b. Hose (2) | Pull from behind steering gear | |
| 2 | Front spring hanger | a. Nut (3) and lock washer (4) | Remove | |
| | | b. Clamp (5) | Remove | From hose (2) |
| 3 | Left axle stop | a. Nut (6) and lock washer (7) | Remove | |
| | | b. Clamp (8) | Remove | From hose (2) |
| 4 | Frame, bottom | a. Nut (9) and lock washer (10) | Remove | |
| | | b. Clamp (11) | Remove | From hose (2) |
| | | c. Tie strap (12) | Cut, Remove, and discard | |

2-58. STEERING SYSTEM MAINTENANCE (CONT)

b. Hydraulic Steering Lines and Fittings (cont).

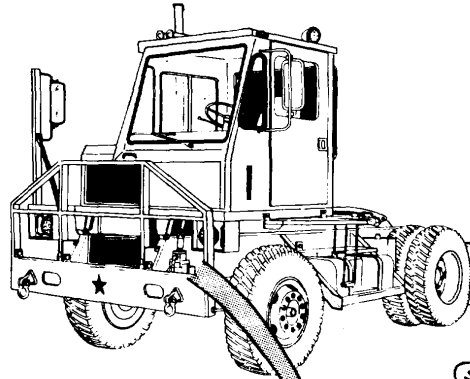

KEY

- 1. Elbow
- 2. Hose
- 3. Nut
- 4. Lock washer
- 5. Clamp
- 6. Nut
- 7. Lock washer
- 8. Clamp
- 9. Nut
- 10. Lock washer
- 11. Clamp
- 12. Tie strap
- 13. Nut
- 14. Lock washer
- 15. Clamp
- 16. Connector
- 17. Clamp
- 18. Clamp
- 19. Hose
- 20. Hose
- 21. 45 degree elbow
- 22. Reducer bushing
- 23. Connector
- 24. Reducer bushing
- 25. Clamp
- 26. Clamp
- 27. Elbow
- 28. Fitting
- 29. Fitting
- 30. Elbow
- 31. Hose
- 32. Fitting

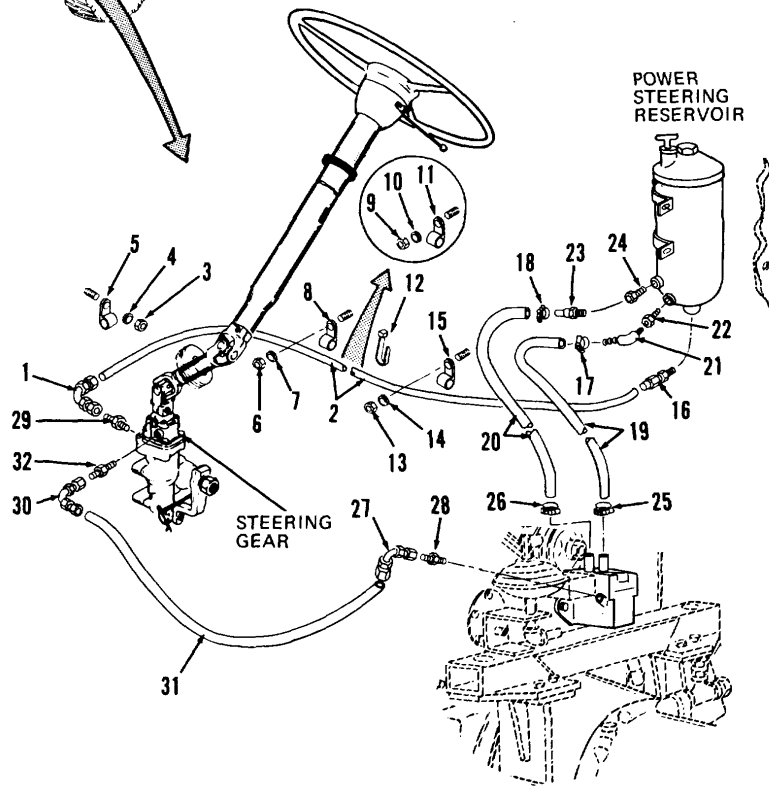

TA236148

2-58. STEERING SYSTEM MAINTENANCE (CONT)

b. Hydraulic Steering Lines and Fittings (cont).

STEP	LOCATION	ITEM	ACTION	REMARKS
REMOVAL (CONT)				
5	Cab guard bottom, left side	a. Nut (13) and lock washer (14)	Remove	
		b. Clamp (15)	Remove	From hose (2)
6	Power steering reservoir	a. Connector (16)	Loosen, disconnect, and cap	Cap prevents entry of foreign matter
		b. Clamps (17 and 18)	Loosen	
		c. Hose (19)	Disconnect	
		d. Clamp (17)	Remove	From hose (19)
		e. Hose (20)	Disconnect	
		f. Clamp (18)	Remove	From hose (20)
		g. Connector (23) and reducer bushing (24)	Remove	
		h. 45 degree elbow (21) and reducer bushing (22)	Remove	
7	Power steering pump	a. Clamps (25 and 26)	Loosen	
		b. Hose (19)	Disconnect and remove	
		c. Clamp (25)	Remove	From hose (19)
		d. Hose (20)	Disconnect and remove	
		e. Clamp (26)	Remove	From hose (20)
		f. Elbow (27)	Loosen, disconnect, and cap	Cap prevents entry of foreign matter
		g. Fitting (28)	Remove	
8.	Steering gear	a. Fitting (29)	Remove	
		b. Elbow (30)	Loosen, disconnect, and cap	Cap prevents entry of foreign matter
		c. Hose (31)	Remove	
		d. Fitting (32)	Remove	

2-58. STEERING SYSTEM MAINTENANCE (CONT)

b. Hydraulic Steering Lines and Fittings (cont).

STEP	LOCATION	ITEM	ACTION	REMARKS
CLEANING				
9	a.	Hoses (2, 19, 20, and 31)	Clean	Use clean cloth moistened with detergent; allow to air dry
<u>WARNING</u>				
Dry cleaning solvent (P-D-680), used to clean parts is toxic and flammable. Wear protective goggles and gloves and use only in a well ventilated area. Avoid contact with skin, eyes, and clothes and don't breathe vapors. Do not use near open flame or excessive heat and don't smoke when using it. Failure to do so could cause serious injury. If you become dizzy while using cleaning solvent, get fresh air and medical attention immediately. If contact with skin or clothes is made, flush with large amounts of water. If contact with eyes is made, wash eyes with water and seek medical aid immediately.				
	b.	All remaining parts	Clean	Use cleaning solvent P-D-680; allow to air dry
INSPECTION				
10	a.	Hoses (2 and 31)	Inspect for: cracks wear chafing	Replace if any defects are observed; refer to step 11 for removal and replacement of connector (16) and elbows (1, 27 and 30)
	b.	Connector (16) and elbows (1, 27, and 30)	Inspect for: cracks breaks thread damage	Replace if any defects are observed; refer to step 11 for removal and replacement
	c.	Hoses (19 and 20)	Inspect for: cracks wear chafing	Replace if any defects are observed; cut replacement hose to same size as original hose
	d.	Elbow (21), connector (23), reducer bushings (22 and 24), and fittings (28, 29, and 32)	Inspect for: cracks deformation thread damage	Replace if any defects are observed

2-58. STEERING SYSTEM MAINTENANCE (CONT)

b. Hydraulic Steering Lines and Fittings (cont).

STEP	LOCATION	ITEM	ACTION	REMARKS
INSPECTION (cont)				
10 (cont)		e. Clamps (5, 8, 11, and 15)	Inspect for: damage cracks	Replace as necessary
		f. Clamps (17, 18, 25, and 26)	Inspect for: damage cracks deformed threads	Replace if any defects are observed

REPAIR

WARNING

If connector (16) and/or elbows (1, 27, and 30) require replacement, discard hose (2 or 31). If hose is reused, hydraulic oil leakage could occur causing loss of steering control. This in turn could cause serious injury or loss of life.

11	Hose (2)	a. Connector (16) b. Mandrel assembly c. Hose (2)	Place connector socket in vise as shown Install in connector nipple; tighten nut of tool connector. Turn tool counterclockwise to remove connector nipple and nut Turn hose (2) clockwise out of connector (16) socket; discard hose
12	Hose (2 or 31)	a. Elbow (1, 27, or 30) b. Hose (2 or 31)	Place elbow socket in vise. Turn elbow counterclockwise to remove nipple and nut from elbow socket Turn hose clockwise out of elbow socket; discard hose

WARNING

Dry cleaning solvent (P-D-680), used to clean parts is toxic and flammable. Wear protective goggles and gloves and use only in a well ventilated area. Avoid contact with skin, eyes, and clothes and don't breathe vapors. Do not use near open flame or excessive heat and don't smoke when using it. Failure to do so could cause serious injury. If you become dizzy while using cleaning solvent, get fresh air and medical attention immediately. If contact with skin or clothes is made, flush with large amounts of water. If contact with eyes is made, wash eyes with water and seek medical aid immediately.

2-58. STEERING SYSTEM MAINTENANCE (CONT)

b. Hydraulic Steering Lines and Fittings (cont).

STEP	LOCATION	ITEM	ACTION	REMARKS
REPAIR (CONT)				
13		Connector (16) and/or elbow (1, 27, or 30)	Clean	Use cleaning solvent P-D-680; allow to air dry. Use wire brush to remove all hose residue from socket and/or nipple of connector or elbows
14	Hose (2 or 31)	a. Hose (2 or 31)	Cut to proper length	Use new hose; use old hose for determining proper length required. Cut hose square using fine tooth hacksaw
		b. Connector (16)	Place connector socket in vise as shown	
		c. Hose (2)	Screw hose counterclockwise into socket until hose bottoms; back hose off 1/4 to 1/2 turn	
		d. Mandrel assembly tool	Oil nipple threads, mandrel assembly tool, and inside of hose liberally using hydraulic oil. Tighten connector nipple and nut on mandrel assembly tool. Apply oil to all parts	
		e. Connector (16)	Screw nipple clockwise into socket and hose. Allow 1/32 to 1/16 inch clearance between nut and socket so nut will swivel. Remove mandrel assembly tool from connector. Remove connector from vise	
15	Hose (2 or 31)	a. Hose (2 or 31)	Cut to proper length	Use new hose; use old hose for determining length required. Cut hose square using fine tooth hacksaw
		b. Elbow (1, 27, or 30)	Place elbow socket in vise	
		c. Hose (2 or 31)	Screw hose counterclockwise into socket until hose bottoms; back off hose 1/4 to 1/2 turn	

2-58. STEERING SYSTEM MAINTENANCE (CONT)

b. Hydraulic Steering Lines and Fittings (cont).

STEP	LOCATION	ITEM	ACTION	REMARKS
------	----------	------	--------	---------

REPAIR (CONT)

15	d. Elbow (1, 27,		Oil nipple threads and inside of hose (cont) and 30) nipple liberally using hydraulic oil. Screw and nut nipple clockwise into socket and hose until nut near nipple bottoms on socket. Remove hose from vise	
----	------------------	--	---	--

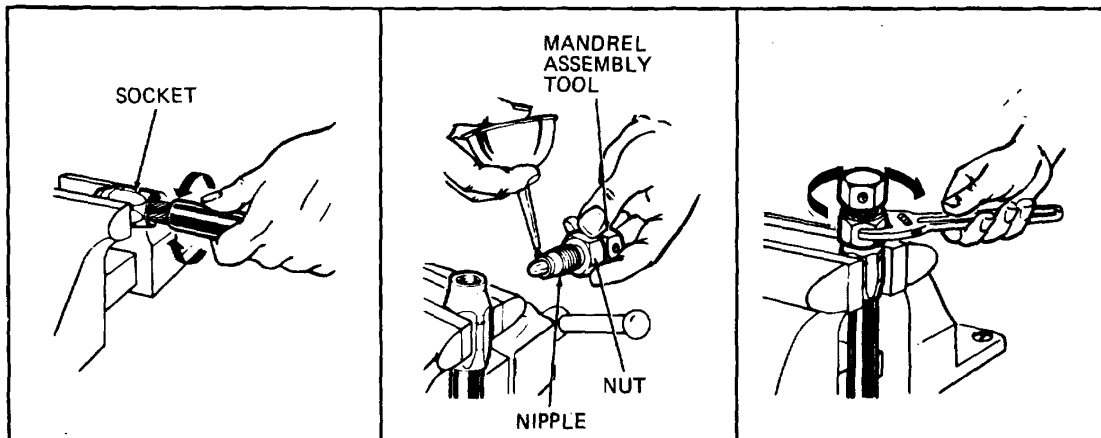

TA236149

INSTALLATION

16	Steering gear	a. Fitting (32)	Install	
		b. Hose (31)	Route	Between steering gear and power steering pump
		c. Elbow (30)	Remove cap, connect, and tighten	To fitting (32)
		d. Fitting (29)	Install	
17	Power steering reservoir	a. Hose (2)	Position	Don't position behind steering gear; route between steering gear and power steering reservoir
		b. Connector (16)	Remove cap, connect, and tighten	To power steering reservoir
		c. Hose (2)	Route	Behind steering gear to fitting (29)

2-58. STEERING SYSTEM MAINTENANCE (CONT)

b. Hydraulic Steering Lines and Fittings (cont).

STEP	LOCATION	ITEM	ACTION	REMARKS
INSTALLATION (CONT)				
18	Steering gear	Elbow (1)	Remove cap, connect, and tighten	To fittings (29)
19	Cab guard bottom, left side	a. Clamp (15)	Install and position	On hose (2)
		b. Lock washer (14) and nut (13)	Install	Secures clamp (15) and hose (2)
20	Frame, bottom	a. Tie strap (12)	Install	Secures hose (2) to existing lines
		b. Clamp (11)	Install and position	On hose (2)
		c. Lock washer (10) and nut (9)	Install	Secures clamp (11) and hose (2)
21	Left axle stop	a. Clamp (8)	Install and position	On hose (2)
		b. Lock washer (7) and nut (6)	Install	Secures clamp (8) and hose (2)
22	Front spring hanger	a. Clamp (5)	Install and position	On hose (2)
		b. Lock washer (4) and nut (3)	Install	Secures clamp (5) and hose (2)
23	Power steering pump	a. Fitting (28)	Install	To fitting (28)
		b. Elbow (27)	Remove cap, connect, and tighten	
		c. Clamps (26 and 25)	Install	On hoses (20 and 19)
		d. Hose (19)	Position and connect	Between power steering pump and power steering reservoir. Connect to power steering pump
		e. Clamp (25)	Position and tighten	On end of hose (19)

2-58. STEERING SYSTEM MAINTENANCE (CONT)

b. Hydraulic Steering Lines and Fittings (cont).

STEP	LOCATION	ITEM	ACTION	REMARKS
INSTALLATION (CONT)				
23 (cont)		f. Hose (20)	Position and connect	Between power steering pump and power steering reservoir. Connect to power steering pump
		g. Clamp (26)	Position and tighten	On end of hose (20)
24	Power steering reservoir	a. Reducer bushing (24) and connector (23)	Install	
		b. Reducer bushing (22) and 45 degree elbow (21)	Install	
		c. Clamp (18)	Install	On hose (20)
		d. Hose (20)	Connect	
		e. Clamp (18)	Position and tighten	On end of hose (20)
		f. Clamp (17)	Install	On hose (19)
		g. Hose (19)	Connect	
		h. Clamp (17)	Position and tighten	On end of hose (19)
25	Power steering reservoir		Fill with hydraulic oil	Para 2-58c

2-58. STEERING SYSTEM MAINTENANCE (CONT)

c. Power Steering Reservoir.

- This task covers:**
- a. Servicing
 - b. Removal
 - c. Disassembly
 - d. Cleaning
 - e. Inspection
 - f. Reassembly
 - g. Installation

INITIAL SETUP

Tools

No. 1 Common Organizational Maintenance
 Tool Kit
 Open end wrench set
 Two quart funnel
 Two gallon container

Personnel Required

Wheel Vehicle Mechanic MOS 63B

Equipment Condition

Paragraph Condition Description

Tractor parked on level surface, parking brake applied, and engine off. Cab tilted 45 degrees.

Materials/Parts

Cleaning solvent Item 1, Appendix C
 Clean cloths Item 2, Appendix C
 Hydraulic oil Item 22, Appendix C
 Gasket FSCM 33457 PN 250389S
 O-ring FSCM 33457 PN 3301603S
 Filter element FSCM 33457 PN LF634

STEP	LOCATION	ITEM	ACTION	REMARKS
SERVICING				
1	Power steering gear, bottom	a. Two gallon container b. Connector	Position a. Loosen b. Disconnect c. Allow to drain d. Cap	Under power steering gear to drain hydraulic oil Para 2-58b Dispose of used oil properly
2	Power steering reservoir, top	a. Dipstick (1)	Remove	

WARNING

Spring (6) is under tension. Hold cover (4) down with your hand when removing capscrew (2). Failure to do so could cause serious injury by cover (4) flying up and hitting your eye. If you are injured, obtain medical aid immediately.

2-58. STEERING SYSTEM MAINTENANCE (CONT)

c. Power Steering Reservoir (cont).

KEY

- | | |
|-------------------|----------------------|
| 1. Dipstick | 9. Capscrews (4) |
| 2. Wing bolt | 10. Shell |
| 3. O-ring | 11. Washers (4) |
| 4. Cover | 12. Capscrews (2) |
| 5. Gasket | 13. Nuts (2) |
| 6. Spring | 14. Lock washers (2) |
| 7. Spring seat | 15. Brackets (2) |
| 8. Filter element | |

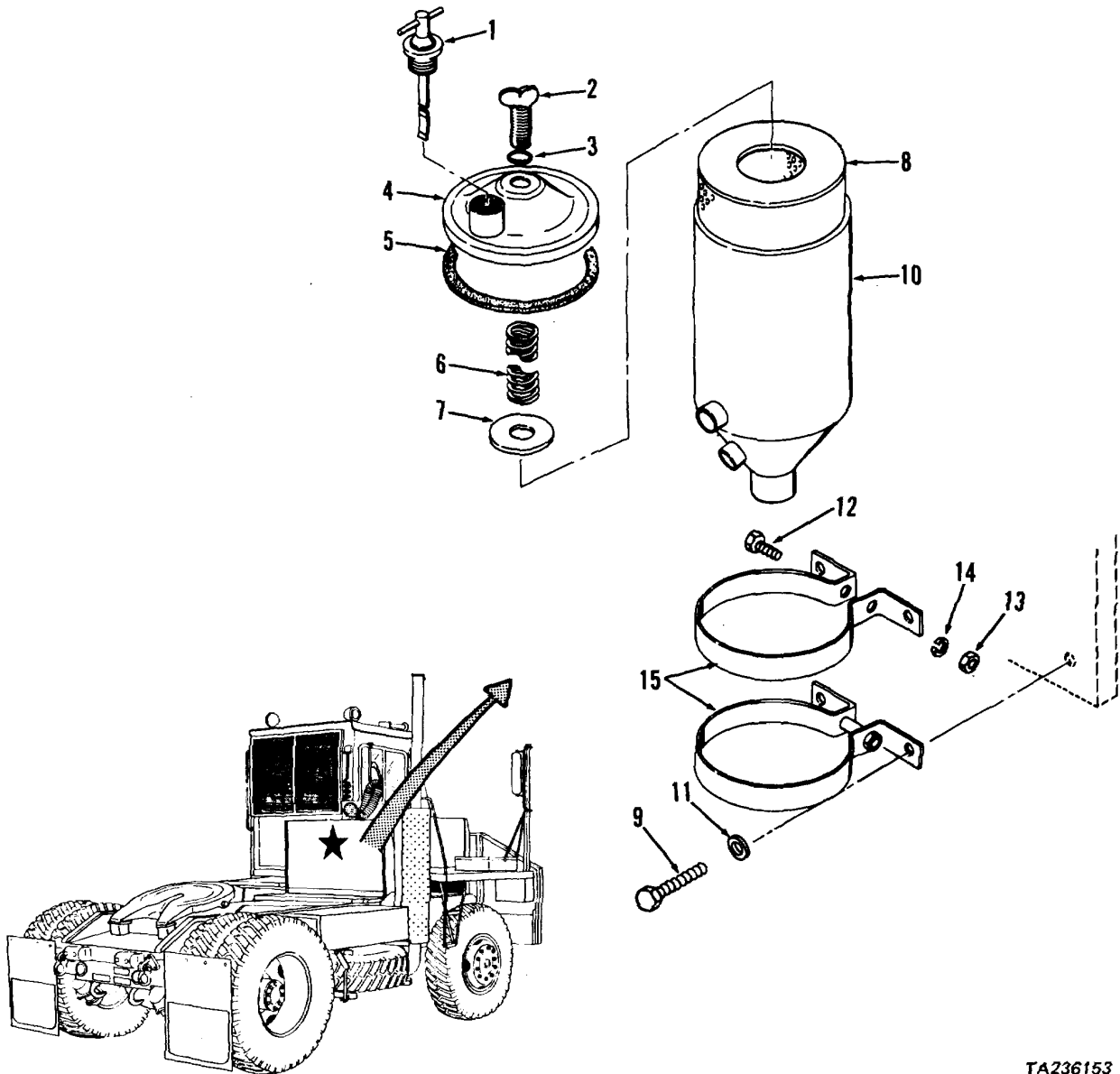

TA236153

2-58. STEERING SYSTEM MAINTENANCE (CONT)

c. Power Steering Reservoir (cont).

STEP	LOCATION	ITEM	ACTION	REMARKS
SERVICING (cont)				
2 (cont)		b. Wing bolt (2) and O-ring (3)	Remove	Discard O-ring (3)
		c. Cover (4) and gasket (5)	Remove	Discard gasket (5)
		d. Spring (6) and spring seat (7)	Remove	
		e. Filter element (8)	Remove and discard	

WARNING

Dry cleaning solvent (P-D-680), used to clean parts is toxic and flammable. Wear protective goggles and gloves and use only in a well ventilated area. Avoid contact with skin, eyes, and clothes and don't breathe vapors. Do not use near open flame or excessive heat and don't smoke when using it. Failure to do so could cause serious injury. If you become dizzy while using cleaning solvent, get fresh air and medical attention immediately. If contact with skin or clothes is made, flush with large amounts of water. If contact with eyes is made, wash eyes with water and seek medical aid immediately.

Compressed air must not exceed 30 psi. Wear safety glasses when drying parts with compressed air. Failure to do so could cause serious injury to eyes and possible blindness. If you hurt your eyes or if a foreign object is blown into your eyes, seek medical attention immediately.

3	Power steering gear, bottom	f. Shell (10) Connector	Clean Remove cap, connect, and tighten	Use cleaning solvent P-D-680; dry using compressed air Para 2-58b
---	-----------------------------	----------------------------	---	--

2-58. STEERING SYSTEM MAINTENANCE (CONT)

c. Power Steering Reservoir (cont).

STEP	LOCATION	ITEM	ACTION	REMARKS
SERVICING (cont)				
4	Power steering reservoir, top	a. New filter element (8)	Install	
		b. Spring seat (7) and spring (6)	Install	
		c. Cover (4) and new gasket (5)	Install	
		d. New O-ring (3) and wing bolt (2)	Install	Press down on cover to compress spring (6)
		e. Hydraulic oil	Install	Fill through dipstick opening to full mark on dipstick (1)
		f. Dipstick (1)	Install	

NOTE

Start engine and turn steering wheel several times. Stop engine and check hydraulic oil level on dipstick (1). Add oil if necessary.

REMOVAL

5	Power steering gear, bottom	a. Two gallon container	Position	Under power steering gear to drain hydraulic oil
		b. Connector	a. Loosen b. Disconnect c. Allow to drain d. Cap	Para 2-58b Dispose of used oil properly
		a. Three hoses and fittings	Disconnect and cap	Para 2-58b
		b. Four capscrews (9) and washers (11)	Remove	Support reservoir
6	Power steering reservoir	c. Two brackets (15), shell (10), and associated parts	Remove	As an assembly

2-58. STEERING SYSTEM MAINTENANCE (CONT)

c. Power Steering Reservoir (cont).

STEP	LOCATION	ITEM	ACTION	REMARKS
DISASSEMBLY				
7	Power steering reservoir	a. Filter element (8)	Remove	As described in step 2 above
		b. Two capscrews (12), nuts (13), and lock washers (14)	Remove	
		c. Two brackets (15)	Remove	Slide off shell (10)

CLEANING**WARNING**

Dry cleaning solvent (P-D-680), used to clean parts is toxic and flammable. Wear protective goggles and gloves and use only in a well ventilated area. Avoid contact with skin, eyes, and clothes and don't breathe vapors. Do not use near open flame or excessive heat and don't smoke when using it. Failure to do so could cause serious injury. If you become dizzy while using cleaning solvent, get fresh air and medical attention immediately. If contact with skin or clothes is made, flush with large amounts of water. If contact with eyes is made, wash eyes with water and seek medical aid immediately.

Compressed air must not exceed 30 psi. Wear safety glasses when drying parts with compressed air. Failure to do so could cause serious injury to eyes and possible blindness. If you hurt your eyes or if a foreign object is blown into your eyes, seek medical attention immediately.

8		All parts	Clean	Use cleaning solvent P-D-680; dry with compressed air
INSPECTION				
9		a. Dipstick (1)	Inspect	Replace if cracked, bent, or otherwise defective
		b. Cover (4) and shell (10)	Inspect	Replace if cracked, dented, threads damaged, or otherwise defective
		c. Spring (6)	Inspect	Replace if coils broken, cracked, or permanently set

2-58. STEERING SYSTEM MAINTENANCE (CONT)

c. Power Steering Reservoir (cont).

STEP	LOCATION	ITEM	ACTION	REMARKS
INSPECTION (cont)				
9 (cont)		d. Spring seat (7)	Inspect	Replace if worn, bent, or otherwise defective
		e. Brackets (15)	Inspect	Replace if cracked or broken
REASSEMBLY				
10	Power steering reservoir	a. Two brackets (15)	Position	Slide onto shell (10)
		b. Two capscrews (12), lock washers (14), and nuts (13)	Install	Do not tighten

NOTE

Complete reassembly of the power steering reservoir will be accomplished after installation.

INSTALLATION

11	Rear cab guard	a. Shell (10) and brackets (15)	Position	
		b. Four capscrews (9) and washers (11)	Install and tighten	
		c. Shell (10)	Position	Tighten two capscrews (12) and nuts (13) after shell (10) is positioned
12	Power steering reservoir, bottom	Fittings and hoses	Install	Para 2-58b

NOTE

Install remaining parts as described in step 4 above.

Section IX. FRAME AND TOWING ATTACHMENTS, SHOCK ABSORBERS, AND BODY AND CAB MAINTENANCE

This section contains the information you need to maintain the:

- Spare Tire Mount and Fifth Wheel
- Shock Absorbers
- Body and Cab

It gives you instructions on how to troubleshoot problems and repair or replace the components that are within the scope of organizational maintenance.

	Para		Para
Troubleshooting Symptom Index.....	2-59	Body and Cab Maintenance.....	2-65
Frame and Towing Attachments		Side Step	2-65a
Troubleshooting	2-60	Mud Flaps and Dock Bumpers	2-65b
Shock Absorbers Troubleshooting	2-61	Rear Platform	2-65c
Body and Cab Troubleshooting.....	2-62	Rear Cab Guard and Heat Shield.....	2-65d
Frame and Towing Attachments		Bumper and Grille Guard.....	2-65e
Maintenance.....	2-63	Hood and Latch and Rear	
Frame Grille	2-63a	Enclosure.....	2-65f
Tow Shackles and Tow Hooks.....	2-63b	Radiator Access Panel	2-65g
Spare Tire Mount	2-63c	Cab Grille.....	2-65h
Fifth Wheel Servicing	2-63d	Door and Arm Rest.....	2-65i
Boom Platform and Latch	2-63e	Rear Window Guard	2-65j
Shock Absorbers Maintenance	2-64	Cab Pivot Pins and Bushings	2-65k
		Seat Belt and Seat.....	2-65l
		Paper Compartment	2-65m
		Tool Box.....	2-65n

2-59. TROUBLESHOOTING SYMPTON INDEX

	Para/Malfunction	Page
FRAME AND TOWING ATTACHMENTS		
Tire carrier will not lower	2-60/1	2-673
Tow shackles will not pivot.....	2-60/2	2-673
Boom platform will not latch or unlatch	2-60/3	2-673
SHOCK ABSORBERS		
Vehicle vibrates excessively during bumps.....	2-61/1	2-673
Harsh bump when vehicle bottoms	2-61/2	2-674
BODY AND CAB		
Seat bottoms or tops out too easily.....	2-62/1	2-674
Seat wobbles.....	2-62/2	2-674
Door sticks, or will not open or close.....	2-62/3	2-675
Hood will not latch or unlatch	2-62/4	2-675
Radiator access panel will not latch or unlatch	2-62/5	2-675
Tool box will not open or close.....	2-62/6	2-676
Cab grille guard will not tilt forward	2-62/7	2-676
Cab difficult to raise or wobbles when raised.....	2-62/8	2-677

2-60. FRAME AND TOWING ATTACHMENTS TROUBLESHOOTING

MALFUNCTION
TEST OR INSPECTION**CORRECTIVE ACTION**

1. TIRE CARRIER WILL NOT LOWER

Step 1. Check if rod nuts are over-tightened.

- a. If rod nuts are over-tightened, loosen until rods will clear tire carrier (para 2-63c).
- b. If rod nuts are not excessively tight, go to step 2 below.

Step 2. Check tire carrier, connecting rod, hanger rod, and mounting parts for damage or bent condition.

If parts are damaged, replace (para 2-63c).

2. TOW SHACKLES WILL NOT PIVOT

Check tow shackles for damage or wear.

If tow shackles are damaged or worn, replace (para 2-63b).

3. BOOM PLATFORM WILL NOT LATCH OR UNLATCH

Check latches and latch brackets for wear or damage.

If parts are damaged or worn, replace (para 2-63e).

2-61. SHOCK ABSORBERS TROUBLESHOOTING
--

MALFUNCTION
TEST OR INSPECTION**CORRECTIVE ACTION**

1. VEHICLE VIBRATES EXCESSIVELY DURING BUMPS

Step 1. Check if shock absorber rubber bushings are worn, deteriorated, or missing.

- a. If rubber bushings are worn, deteriorated, or missing, replace (para 2-64).
- b. If rubber bushings are not worn, deteriorated, or missing, go to step 2 below.

2-61. SHOCK ABSORBERS TROUBLESHOOTING (CONT)

MALFUNCTION**TEST OR INSPECTION****CORRECTIVE ACTION**

1. VEHICLE VIBRATES EXCESSIVELY DURING BUMPS (Cont)

Step 2. Check if shock absorbers are leaking or damaged. Remove shock absorbers (para 2-64) and check operation.

- a. If a shock absorber is leaking or operation is jerky, replace both shock absorbers (para 2-64).
- b. If shock absorbers operate smoothly and are not leaking, notify direct support maintenance.

2. HARSH BUMP WHEN VEHICLE BOTTCMS

Check if rubber blocks are cracked, deteriorated, or missing.

If rubber blocks are cracked, deteriorated, or missing, replace (para 2-64).

2-62. BODY AND CAB TROUBLESHOOTING

MALFUNCTION**TEST OR INSPECTION****CORRECTIVE ACTION**

1. SEAT BOTTOMS OR TOPS OUT TOO EASILY

Check if seat is correctly adjusted for operator's weight.

- a. If seat is not correctly adjusted for operator's weight, adjust (refer to Operator's Manual, TM 9-2320-285-10).
- b. If seat is correctly adjusted for operator's weight, notify direct support maintenance.

2. SEAT WOBBLES

Check seat mounting parts for looseness, wear, or damage.

If seat mounting parts are loose, tighten (para 2-651); if parts are worn or damaged, replace (para 2-651).

2-62. BODY AND CAB TROUBLESHOOTING (CONT)**MALFUNCTION****TEST OR INSPECTION****CORRECTIVE ACTION****3. DOOR STICKS, OR WILL NOT OPEN OR CLOSE**

Step 1. Check for obstructions at door edges.

- a. If obstructions are found, remove.
- b. If obstructions are not found, go to step 2 below.

Step 2. Check if hinge, door jamb, or door restraints are bent or damaged.

- a. If parts are bent or damaged, replace (para 2-65i).
- b. If parts are not bent or damaged, go to step 3 below.

Step 3. Check if striker bolt is loose, bent, or damaged.

- a. If striker bolt is loose, bent, or damaged, replace (para 2-65i).
- b. If striker bolt is okay, notify direct support maintenance.

4. HOOD WILL NOT LATCH OR UNLATCH

Step 1. Check hood latch parts for damage, wear, or bent condition.

- a. If parts are damaged, worn, or bent, replace (para 2-65f).
- b. If parts are not damaged, worn, or bent, go to step 2 below.

Step 2. Check hood for damage or distortion.

If hood is distorted or damaged, replace (para 2-65f).

5. RADIATOR ACCESS PANEL WILL NOT LATCH OR UNLATCH

Step 1. Check radiator access panel latch for bent condition or damage.

- a. If latch is bent or damaged, replace (para 2-65g).
- b. If latch is not bent or damaged, go to step 2 below.

Step 2. Check if rubber strips are cracked, worn, or deteriorated.

- a. If rubber strips are cracked, worn, or deteriorated, replace (para 2-65g).
- b. If rubber strips are okay, go to step 3 below.

2-62. BODY AND CAB TROUBLESHOOTING (CONT)
--

MALFUNCTION**TEST OR INSPECTION****CORRECTIVE ACTION****5. RADIATOR ACCESS PANEL WILL NOT LATCH OR UNLATCH (Cont)**

Step 3. Check if radiator access panel or hinge is damaged or distorted.

If radiator access panel or hinge is damaged or distorted, replace (para 2-65g).

6. TOOL BOX WILL NOT OPEN OR CLOSE

Check tool box for cracks, wear, or distortion.

If tool box is cracked, worn, or distorted, replace (para 2-65n).

7. CAB GRILLE GUARD WILL NOT TILT FORWARD**WARNING**

Support cab grille guard before removing pins. Grille guard is heavy; do not allow it to fall forward freely. Failure to follow this procedure could result in injury from falling grille guard. If you are injured, obtain medical aid immediately.

Step 1. Try to remove pins from grille guard (para 2-65e).

- a. If pins can not be removed, go to step 2 below.
- b. If pins are removed, go to step 3 below.

Step 2. Check pins and pin retainers for cracks, wear, or bent or twisted condition.

- a. If pins or pin retainers are cracked, worn, bent, or twisted, replace (para 2-65e).
- b. If pins and pin retainers are not cracked, worn, bent, or twisted, go to step 4 below.

Step 3. Check if grille guard mounting parts are bent, damaged, or over-tightened.

- a. If grille guard mounting parts are over-tightened, loosen; if parts are bent or damaged, replace (para 2-65e).
- b. If grille guard mounting parts are not bent, damaged, or over-tightened, go to step 4 below.

2-62. BODY AND CAB TROUBLESHOOTING (CONT)**MALFUNCTION****TEST OR INSPECTION****CORRECTIVE ACTION****7. CAB GRILLE GUARD WILL NOT TILT FORWARD (Cont)**

Step 4. Check grille guard for cracks, wear, or distortion.

If grille guard is cracked, worn, or distorted, replace (para 2-65e).

8. CAB DIFFICULT TO RAISE OR WOBBLER WHEN RAISED

Step 1. Check cab pivot pins and bushings for looseness, wear, damage, or bent condition.

a. If pivot pins and bushings are loose, tighten (para 2-65k); if worn, damaged, or bent, replace (para 2-65k).

b. If pivot pins and bushings are not loose, worn, damaged, or bent, go to step 2 below.

Step 2. Check pivot pins for inadequate lubrication. Check lubrication fittings for damage.

a. If pivot pins are inadequately lubricated, lubricate (para 2-65k).

b. If lubrication fittings are damaged, replace (para 2-65k).

c. If pivot pins are adequately lubricated and lubrication fittings are not damaged, notify direct support maintenance.

2-63. FRAME AND TOWING ATTACHMENTS MAINTENANCE

- a. Frame Grille.

This task covers:

- a. Removal
- b. Cleaning
- c. Inspection
- d. Installation

INITIAL SETUP:

Tools

Socket wrench set, 3/8 inch drive
Welding shop equipment
Air compressor

Materials/Parts

Cleaning solvent Item 1, Appendix C
Clean cloths Item 2, Appendix C

Personnel Required

Wheel Vehicle Mechanic MOS 63B

Equipment Condition

Paragraph Condition Description

Vehicle parked on level surface and engine off.

KEY

- 1. Capscrews (4)
- 2. Locknuts (4)
- 3. Washers (4)
- 4. Frame grille

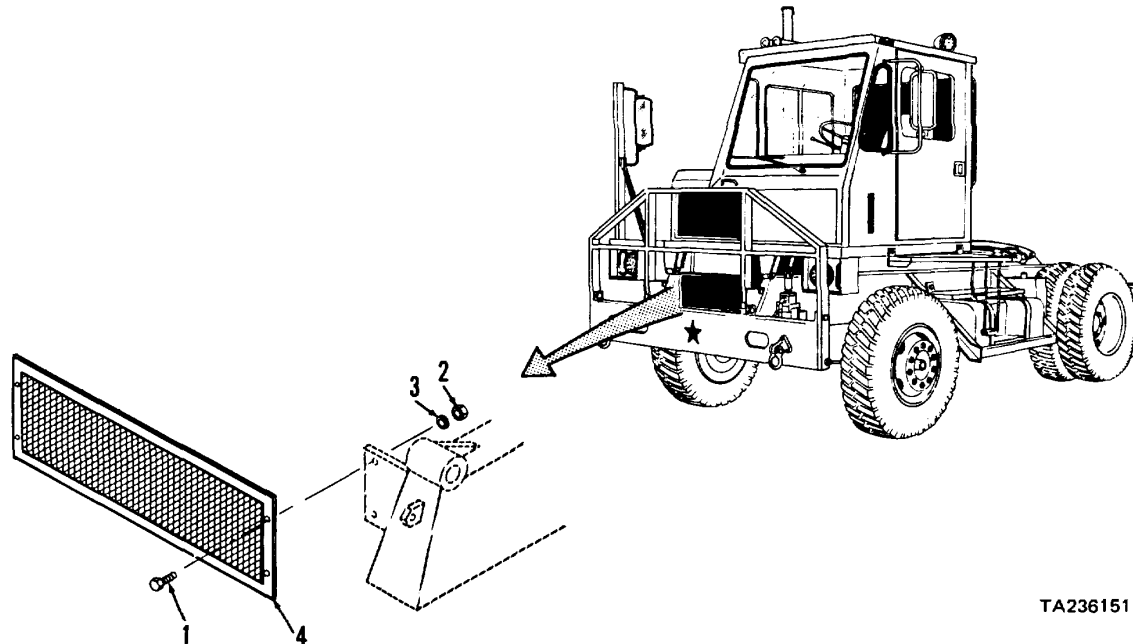

TA236151

STEP	LOCATION	ITEM	ACTION	REMARKS
------	----------	------	--------	---------

REMOVAL

1	Front of vehicle behind grille guard	a. Four capscrews (1), locknuts (2), and washers (3)	Remove	Support frame grille (4)
		b. Frame grille (4)	Remove	

2-63. FRAME AND TOWING ATTACHMENTS MAINTENANCE (CONT)

- a. Frame Grille (cont).

STEP	LOCATION	ITEM	ACTION	REMARKS
------	----------	------	--------	---------

CLEANING

WARNING

Dry cleaning solvent (P-D-680), used to clean parts is toxic and flammable. Wear protective goggles and gloves and use only in a well ventilated area. Avoid contact with skin, eyes, and clothes and don't breathe vapors. Do not use near open flame or excessive heat and don't smoke when using it. Failure to do so could cause serious injury. If you become dizzy while using cleaning solvent, get fresh air and medical attention immediately. If contact with skin or clothes is made, flush with large amounts of water. If contact with eyes is made, wash eyes with water and seek medical aid immediately.

Compressed air must not exceed 30 psi. Wear safety glasses when drying parts with compressed air. Failure to do so could cause serious injury to eyes and possible blindness. If you hurt your eyes or if a foreign object is blown into your eyes, seek medical attention immediately.

2		All parts	Clean	Use cleaning solvent P-D-680; dry with compressed air
---	--	-----------	-------	---

INSPECTION

3		a. Frame grille (4)	Inspect for: broken welds cracks dents	Replace if necessary. Repair broken welds by welding
		b. All other parts	Inspect for: damaged threads	Replace if necessary

INSTALLATION

4	Front of vehicle behind grille guard	a. Frame grille (4)	Position
		b. Four capscrews (1), washers (2), and locknuts (3)	Install and tighten

2-63. FRAME AND TOWING ATTACHMENTS MAINTENANCE (CONT)

b. Tow Shackles and Tow Hooks.

This task covers:

- a. Removal
- b. Cleaning
- c. Inspection
- d. Installation

INITIAL SETUP:

Tools

Socket wrench set, 3/8 inch drive
Air compressor

Personnel Required

Wheel Vehicle Mechanic MOS 63B

Materials/Parts

Cleaning solvent
Clean cloths

Paragraph
Item 1, Appendix C
Item 2, Appendix C

Equipment Condition

Condition Description

Vehicle parked on level surface and engine off.

KEY

- 1. Capscrews (6)
- 2. Locknuts (6)
- 3. Washers (6)
- 4. Tow shackles (2)
- 5. Capscrews (2)
- 6. Capscrews (2)
- 7. Locknuts (2)
- 8. Locknuts (2)
- 9. LH tow hook
- 10. RH tow hook
- 11. Capscrews (6)
- 12. Lock washers (6)
- 13. Tow shackles (2)

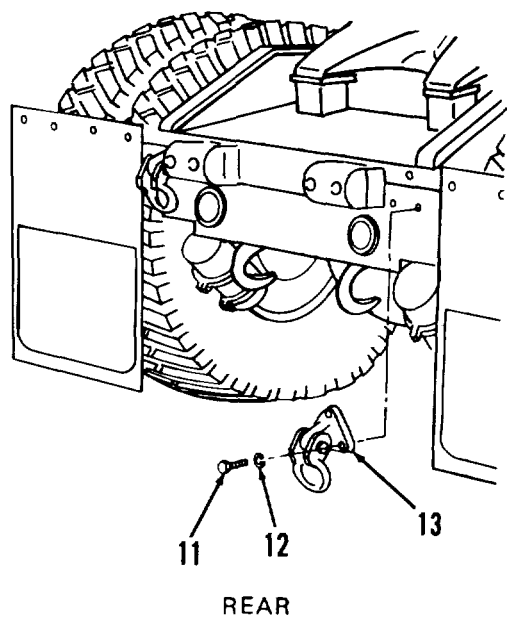
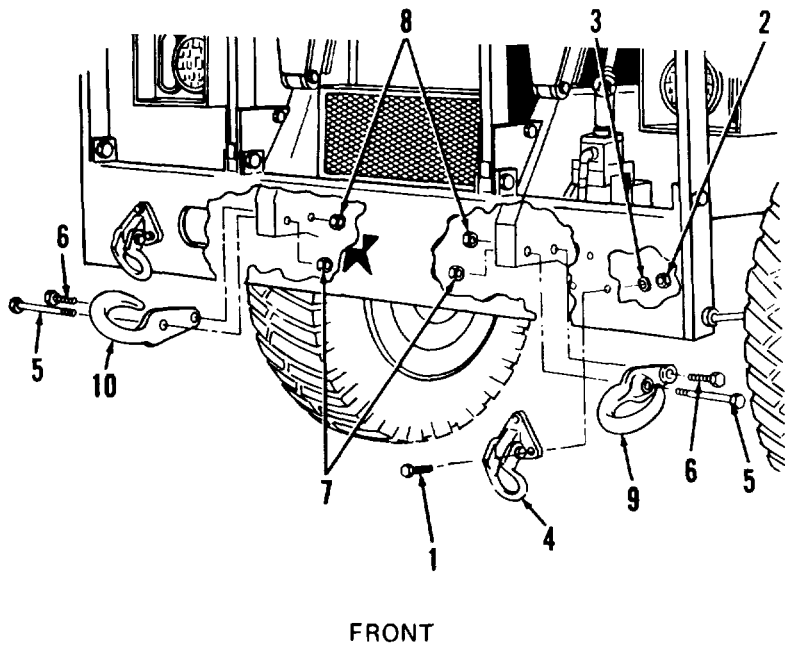

TA236152

2-63. FRAME AND TOWING ATTACHMENTS MAINTENANCE (CONT)

b. Tow Shackles and Tow Hooks (cont).

STEP	LOCATION	ITEM	ACTION	REMARKS
------	----------	------	--------	---------

REMOVAL

1	Front of vehicle on front bumper	a. Three capscrews (1), locknuts (2), and washers (3)	Remove	Support tow shackle (4)
		b. Tow shackle (4)	Remove	

NOTE

Perform step 1 above to remove the remaining tow shackle.

2	Front of vehicle behind front bumper	a. Four capscrews (5 and 6) and locknuts (7 and 8)	Remove	Support tow hook (9 or 10)
		b. Tow hook (9 or 10)	Remove	

NOTE

Perform step 2 above to remove remaining tow hook.

3	Rear of vehicle	a. Three capscrews (11) and lock washers (12)	Remove	Support tow shackle (13)
		b. Tow shackle (13)	Remove	

NOTE

Perform step 3 above to remove remaining tow shackle.

2-43. FRAME AND TOWING ATTACHMENTS MAINTENANCE (CONT)

b. Tow Shackles and Tow Hooks (cont).

STEP	LOCATION	ITEM	ACTION	REMARKS
------	----------	------	--------	---------

CLEANING

WARNING

Dry cleaning solvent (P-D-680), used to clean parts is toxic and flammable. Wear protective goggles and gloves and use only in a well ventilated area. Avoid contact with skin, eyes, and clothes and don't breathe vapors. Do not use near open flame or excessive heat and don't smoke when using it. Failure to do so could cause serious injury. If you become dizzy while using cleaning solvent, get fresh air and medical attention immediately. If contact with skin or clothes is made, flush with large amounts of water. If contact with eyes is made, wash eyes with water and seek medical aid immediately.

Compressed air must not exceed 30 psi. Wear safety glasses when drying parts with compressed air. Failure to do so could cause serious injury to eyes and possible blindness. If you hurt your eyes or if a foreign object is blown into your eyes, seek medical attention immediately.

4		All parts	Clean	Use cleaning solvent P-D-680; dry using compressed air
---	--	-----------	-------	--

INSPECTION

5		a. Tow shackles (4 and 13) and tow hooks (9 and 10)	Inspect	Replace if cracked, broken, or deformed
		b. Remaining parts	Inspect	Replace if deformed or threads damaged

INSTALLATION

6	Rear of vehicle	a. Tow shackle (13)	Position	
		b. Three cap-screws (11) and lock washers (12)	Install and tighten	

2-3. FRAME AND TOWING ATTACHMENTS MAINTENANCE (CONT)

b. Tow Shackles and Tow Hooks (cont).

STEP	LOCATION	ITEM	ACTION	REMARKS
------	----------	------	--------	---------

INSTALLATION (cont)

NOTE

Perform step 6 above to install remaining tow shackle.

7	Front of vehicle behind front bumper	a. Tow hook (9 or 10)	Position
		b. Four capscrews (5 and 6) and locknuts (7 and 8)	Install and tighten

NOTE

Perform step 7 above to install remaining tow hook.

8	Front of vehicle on front bumper	a. Tow shackle (4)	Position
		b. Three capscrews (1), washers (3), and locknuts (2)	Install and tighten

NOTE

Perform step 8 above to install remaining tow shackle.

2-63. FRAME AND TOWING ATTACHMENTS MAINTENANCE (CONT)

- c. Spare Tire Mount.

This task covers:

- a. Removal
- b. Cleaning
- c. Inspection/Repair
- d. Installation

INITIAL SETUP:

Tools

- No. 1 Common Organizational Maintenance Tool Kit
 - Safety glasses
 - Open end wrench set
 - Socket wrench set, 3/8 inch drive
 - Scratch wire brush
- Air compressor
- Screw threading set
- Welding shop equipment

Materials/Parts

- Cleaning solvent Item 1, Appendix C
- Clean cloths Item 2, Appendix C
- Detergent Item 27, Appendix C

Personnel Required

Two Wheel Vehicle Mechanics MOS 63B

Equipment Condition

Paragraph	Condition Description
	Parked on level surface; parking brake applied; engine off.

STEP	LOCATION	ITEM	ACTION	REMARKS
------	----------	------	--------	---------

REMOVAL

1	Middle right side of vehicle	a. Padlock (1)	Unlock and remove	If necessary
		b. Chain (2) and sleeve (3)	Remove	If necessary
		c. Tire carrier (8)	Lift and lower	Just enough to disengage nuts (4) by moving rods (12 and 13) outward
		d. Two lug nuts (9)	Remove	
		e. Spare tire	Remove	Lift from tire carrier (8)
		f. Two nuts (4)	Remove	
		g. Tire carrier (8)	Support	In rear
		h. Two nuts (5), washers (6) and capscrews (7)	Remove	
		i. Tire carrier (8)	Remove	

2-63. FRAME AND TOWING ATTACHMENTS MAINTENANCE (CONT)

c. Spare Tire Mount (cont).

KEY

- 1. Padlock
- 2. Chain
- 3. Sleeve
- 4. Nuts (2)
- 5. Nuts (2)
- 6. Washers (2)
- 7. Capscrews (2)
- 8. Tire carrier
- 9. Lug nuts (2)
- 10. Nuts (2)
- 11. Washers (2)
- 12. Connecting rod
- 13. Hanger rod

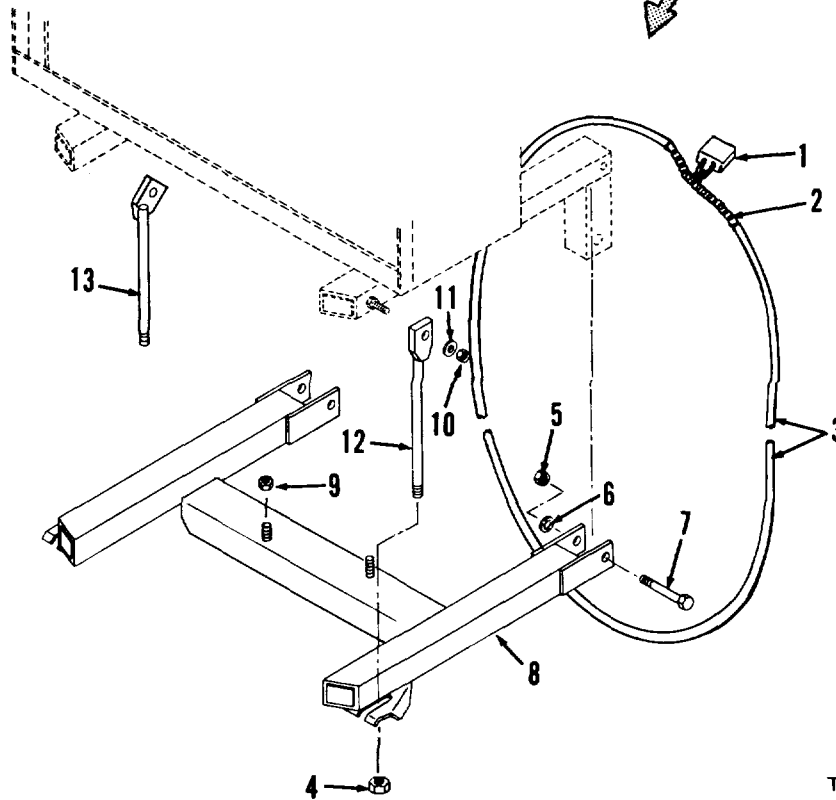
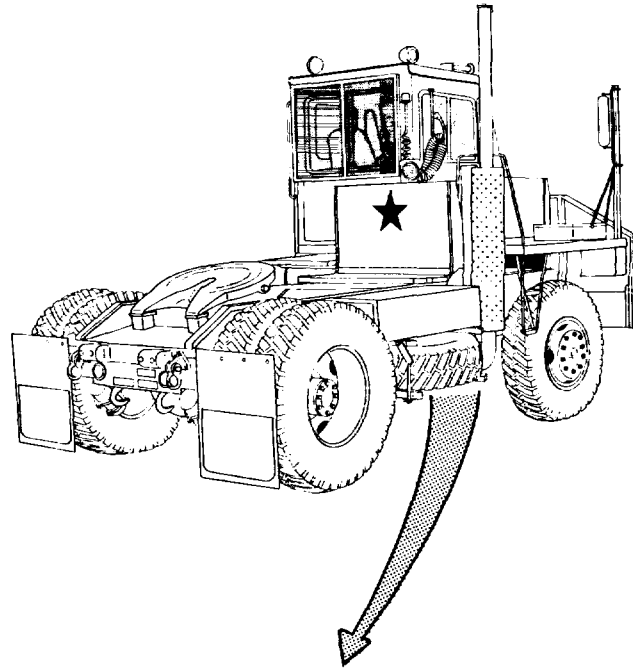

TA236154

2-63. FRAME AND TOWING ATTACHMENTS MAINTENANCE (CONT)
--

c. Spare Tire Mount (cont).

STEP	LOCATION	ITEM	ACTION	REMARKS
REMOVAL (cont)				
1 (cont) (11)		j. Two nuts (10) and washers	Remove	
		k. Connecting rod (12) and hanger rod (13)	Remove	
CLEANING				
2		a. Chain (2) and sleeve (3)	Clean	Wipe with clean cloth moistened with mild detergent solution; dry with clean cloth

WARNING

Dry cleaning solvent (P-D-680), used to clean parts is toxic and flammable. Wear protective goggles and gloves and use only in a well ventilated area. Avoid contact with skin, eyes, and clothes and don't breathe vapors. Do not use near open flame or excessive heat and don't smoke when using it. Failure to do so could cause serious injury. If you become dizzy while using cleaning solvent, get fresh air and medical attention immediately. If contact with skin or clothes is made, flush with large amounts of water. If contact with eyes is made, wash eyes with water and seek medical aid immediately.

Compressed air must not exceed 30 psi. Wear safety glasses when drying parts with compressed air. Failure to do so could cause serious injury to eyes and possible blindness. If you hurt your eyes or if a foreign object is blown into your eyes, seek medical attention immediately.

b. All other parts	Clean	Use cleaning solvent P-D-680. Use wire brush to remove rust if necessary. Dry with compressed air
--------------------	-------	---

2-63. FRAME AND TOWING ATTACHMENTS MAINTENANCE (CONT)

c. Spare Tire Mount (cont).

STEP	LOCATION	ITEM	ACTION	REMARKS
INSPECTION/REPAIR				
3		a. Padlock (1)	Inspect for: smooth action damage	Replace if necessary
		b. Chain (2)	Inspect for: damage broken links	Replace if necessary
		c. Sleeve (3)	Inspect for: worn areas cracks cuts	Replace if necessary
		d. Tire carrier (8)	Inspect for: broken welds bent studs damaged threads cracks dents	Repair broken welds by weld- ing. Repair bent studs by straightening. Use 3/4-16 die to chase threads. Replace tire carrier if other defects are observed
		e. Rods (12 and 13)	Inspect for: damaged threads cracks bends	Chase damaged threads using 3/4-16 die. Replace part if other defects observed
INSTALLATION				
4	Middle right side of vehicle	a. Hanger rod (13)	Position on stud	
		b. Connecting rod (12)	Position on stud	
		c. Two nuts (10) and washers (11)	Install	
		d. Two lug nuts (9)	Install	On tire carrier studs only if spare tire is not to be in- stalled
		e. Tire carrier (8)	Position and support rear	
		f. Two capscrews (7), washers (6), and nuts (5)	Install	Align holes in spare tire carrier weldment/battery box and tire carrier (8)

2-63. FRAME AND TOWING ATTACHMENTS MAINTENANCE (CONT)
--

c. Spare Tire Mount (cont).

STEP	LOCATION	ITEM	ACTION	REMARKS
INSTALLATION (cont)				
4 (cont)		g. Two nuts (4)	Install	On rods (12 and 13)
		h. Spare tire	Position	On tire carrier (8)
		i. Lug nuts (9)	Install	Secures spare tire to carrier
		j. Tire carrier (8)	Lift	Just enough to engage rods in slots without interference from nuts (4)
		k. Two nuts (4)	Tighten	
	l. Chain (2)	Install		Around spare tire, tire car- rier (8), and battery box weldment as shown to deter theft of spare tire
	m. Padlock (1)		Install and lock	Deters theft of spare tire

2-688

12-3. FRAME AND TOWING ATTACHMENTS MAINTENANCE (CONT)

d. Fifth Wheel Servicing. This task covers servicing of the fifth wheel.

INITIAL SETUP:

Tools

Grease gun
Hand oiler

Materials/Parts

Clean cloths	Item 2, Appendix C
Grease	Item 3, Appendix C
Engine oil	Item 24, Appendix C

Personnel Required

Wheel Vehicle Mechanic MOS 63B

Equipment Condition

Paragraph	Condition Description
-----------	-----------------------

Vehicle parked on level surface and engine off.
Fifth wheel boom platform removed.

KEY

1. Lubrication fittings (2)
2. Lubrication fittings (4)
3. Lubrication fittings (2)

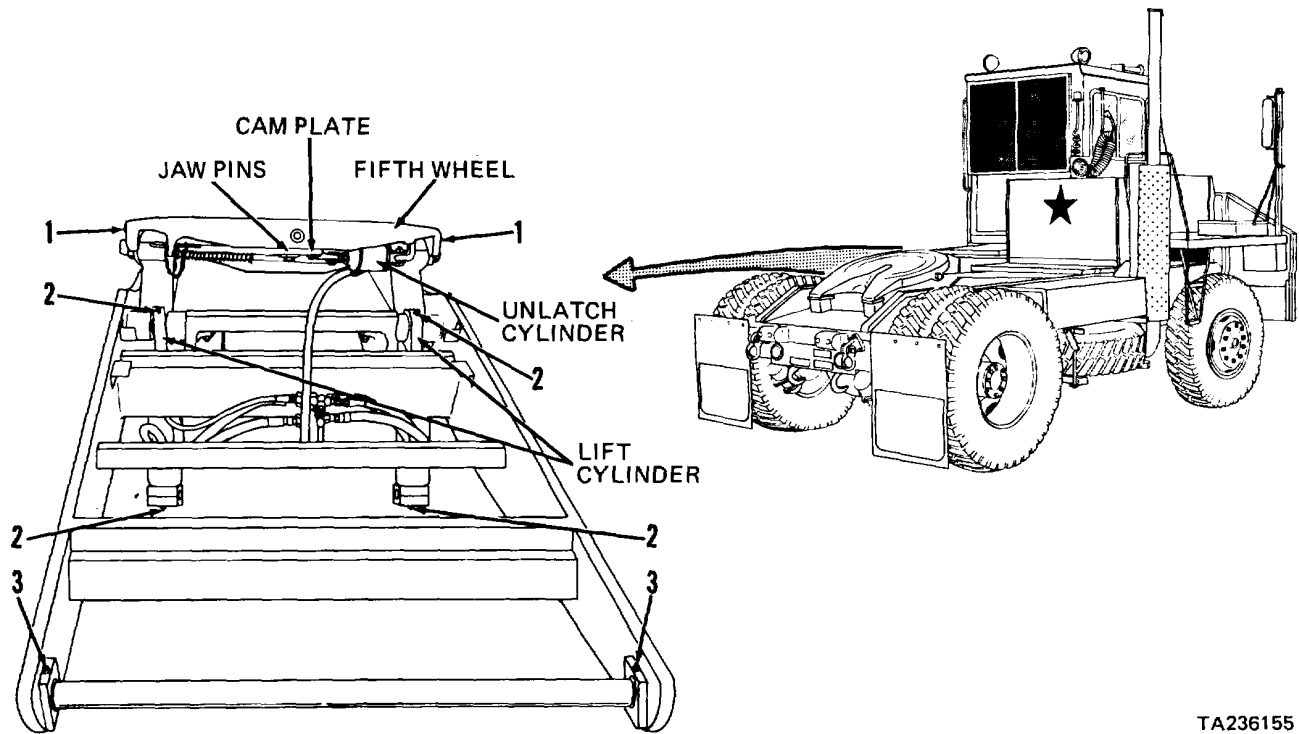

TA236155

2-63. FRAME AND TOWING ATTACHMENTS MAINTENANCE (CONT)

d. Fifth Wheel Servicing (cont).

STEP	LOCATION	ITEM	ACTION	REMARKS
SERVICING				
1	Fifth wheel	a. Two lubrication fittings (1)	Clean; then apply grease	Use clean cloth; apply grease until fresh grease is forced out
		b. Fifth wheel surface	Apply grease	Apply liberally over top surface
2	Cam plate	a. Clevis pin	Apply oil liberally	
		b. Jaw pin	Apply oil liberally	
3	Lift cylinders, top and bottom pivot points	Four lubrication fittings (2)	Clean; then apply grease	Use clean cloth; apply grease until fresh grease is forced out
4	Boom pivot points	Two lubrication fittings (3)	Clean; then apply grease	Use clean cloth; apply grease until fresh grease is forced out
5	Tractor rear	Fifth wheel boom platform	Install	Para 2-63e

2-63. FRAME AND TOWING ATTACHMENTS MAINTENANCE (CONT)

- e. Boom Platform and Latch Assembly.

This task covers:

- a. Removal
- b. Cleaning
- c. Inspection
- d. Installation

INITIAL SETUP:

Tools

Flat tip screwdriver, 1/8 inch
 Socket wrench set, 3/8 inch drive
 Screw threading set
 Welding shop equipment
 Air compressor

Personnel Required

Wheel Vehicle Mechanic MOS 63B

Equipment Condition

Paragraph Condition Description

Vehicle parked on level surface, engine off, and parking brake applied.

Materials/Parts

Cleaning solvent Item 1, Appendix C
 Clean cloths Item 2, Appendix C
 Detergent Item 27, Appendix C

STEP	LOCATION	ITEM	ACTION	REMARKS
------	----------	------	--------	---------

REMOVAL

1	Boom assembly, rear	a. Two latches (8)	Pull up and away from latch bracket (4)	
		b. Boom platform (1)	Lift back end, pull out, and remove	

NOTE

Don't perform the following steps unless inspection indicates replacement of latch assemblies is necessary.

2	Boom platform (1)	a. Four capscrews (2) and lock-nuts (3)	Remove	Support latch brackets (4)
		b. Two latch brackets (4)	Remove	
3	Boom tie plate	a. Two cotter pins (5)	Remove	
		b. Two washers (6)	Remove	
		c. Two shafts (7)	Remove	Support latches (8)
		d. Two latches (8)	Remove	
		e. Four screws (9) and lock washers (10)	Remove	Support pivot brackets (11)

2-63. FRAME AND TOWING ATTACHMENTS MAINTENANCE (CONT)

e. Boom Platform and Latch Assembly (cont).

KEY

- 1. Boom platform
- 2. Screws (4)
- 3. Locknuts (4)
- 4. Latch brackets (2)
- 5. Cotter pins (2)
- 6. Washers (2)
- 7. Shafts (2)
- 8. Latches (2)
- 9. Screws (4)
- 10. Lock washers (4)
- 11. Pivot brackets (2)

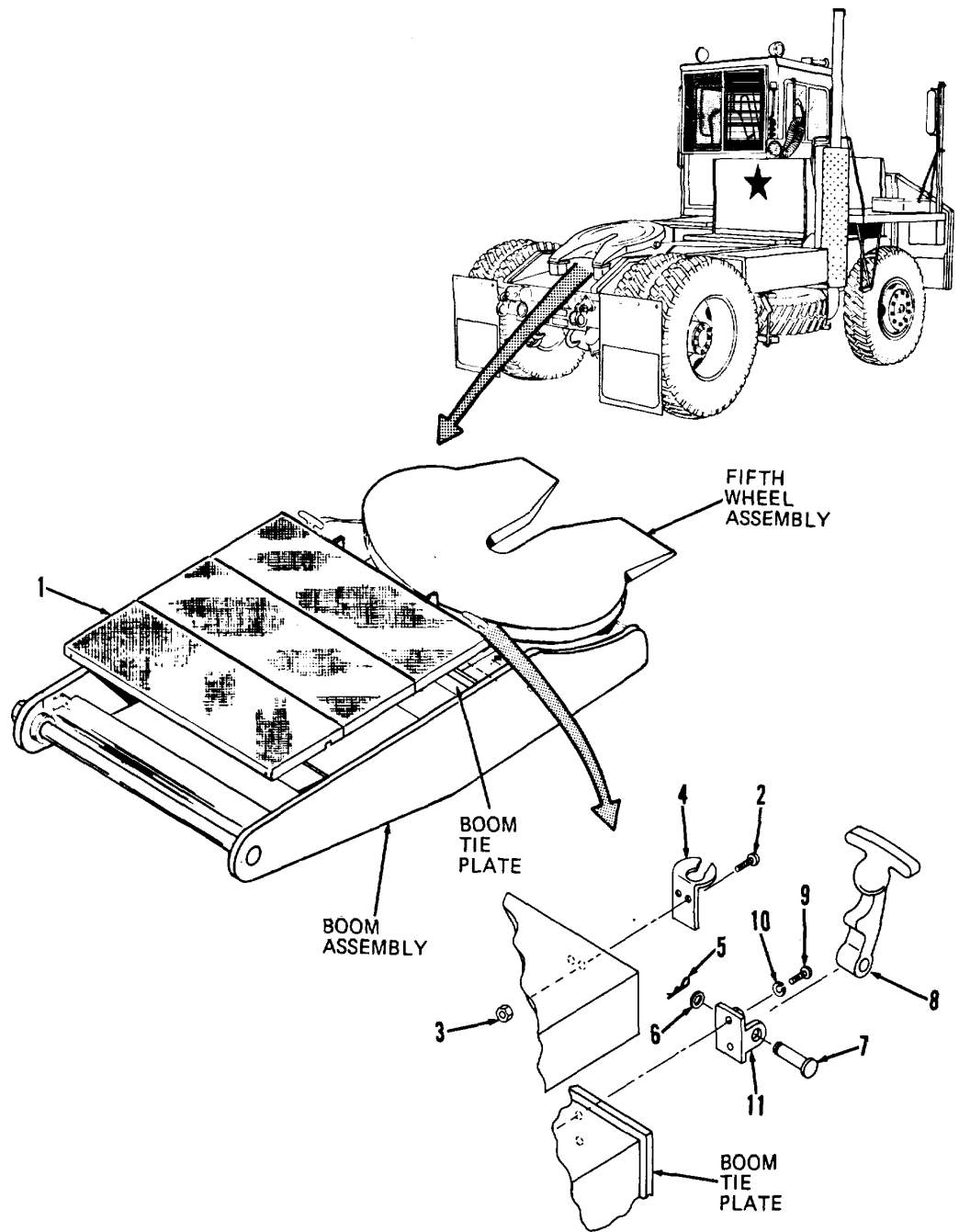

TA236150

2-63. FRAME AND TOWING ATTACHMENTS MAINTENANCE (CONT)

e. Boom Platform and Latch Assembly (cont).

STEP	LOCATION	ITEM	ACTION	REMARKS
REMOVAL (cont)				
3 (cont)		f. Two pivot brackets (11)	Remove	
CLEANING				
4		a. Latches (8)	Clean	Use clean cloth moistened with detergent. Rinse with clear water and dry with clean cloths

WARNING

Dry cleaning solvent (P-D-680), used to clean parts is toxic and flammable. Wear protective goggles and gloves and use only in a well ventilated area. Avoid contact with skin, eyes, and clothes and don't breathe vapors. Do not use near open flame or excessive heat and don't smoke when using it. Failure to do so could cause serious injury. If you become dizzy while using cleaning solvent, get fresh air and medical attention immediately. If contact with skin or clothes is made, flush with large amounts of water. If contact with eyes is made, wash eyes with water and seek medical aid immediately.

Compressed air must not exceed 30 psi. Wear safety glasses when drying parts with compressed air. Failure to do so could cause serious injury to eyes and possible blindness. If you hurt your eyes or if a foreign object is blown into your eyes, seek medical attention immediately.

		b. All other parts	Clean	Use cleaning solvent P-D-680; dry using compressed air
INSPECTION				
5		a. Boom platform (1)	Inspect for: broken welds cracks breaks	Repair broken welds by welding; replace if other defects observed
		b. Latch brackets (4) and pivot brackets (11)	Inspect for: cracks breaks	Replace if necessary

2-63. FRAME AND TOWING ATTACHMENTS MAINTENANCE (CONT)
--

e. Boom Platform and Latch Assembly (cont).

STEP	LOCATION	ITEM	ACTION	REMARKS
INSPECTION (cont)				
5 (cont)		c. Cotter pins (5) and washers (6)	Inspect for: deformation cracks	Replace if necessary
		d. Shafts (7)	Inspect for: cracks wear deformation	Replace if necessary
		e. Latches (8)	Inspect for: cracks breaks damage	Replace if necessary
		f. Boom tie plate	Inspect	For deformed or damaged threads at pivot brackets (11) mounting holes. Repair using 10-24 tap
INSTALLATION				
6	Boom tie plate	a. Two pivot brackets (11)	Position	Over mounting holes
		b. Four lock washers (10) and screws (9)	Install	
		c. Two latches (8)	Position	Between ears of pivot brackets (11)
		d. Two shafts (7)	Install	Through pivot brackets (11) ears and latches (8)
		e. Two washers (6)	Install	
		f. Two cotter pins (5)	Install	On shaft (7)
7	Boom platform (1)	a. Two latch brackets (4)	Position	Over mounting holes
		b. Four screws (2) and locknuts (3)	Install	
8	Boom assembly, rear	a. Boom platform (1)	Install	Insert front under lip of boom platform hold bracket, and lower back of platform into position
		b. Two latches (8)	Pull up and over latch bracket (4) to secure	

2-64. SHOCK ABSORBERS MAINTENANCE

This task covers:

- a. Removal
- b. Cleaning
- c. Inspection
- d. Installation

INITIAL SETUP:

Tools

- No. 1 Common Organizational Maintenance Tool Kit
- Safety glasses
- Adjustable open end wrench
- Combination wrench set
- Soft hammer

Personnel Required

Wheel Vehicle Mechanic MOS 63B

Equipment Condition

Paragraph Condition Description
 Parked on level surface; parking brake applied; engine off.

Materials/Part s

- Cleaning solvent Item 1, Appendix C
- Clean cloths Item 2, Appendix C
- Grease Item 3, Appendix C
- Detergent Item 27, Appendix C

STEP	LOCATION	ITEM	ACTION	REMARKS
REMOVAL				
1	Tractor cab	a. Key switch	Turn on	To start engine
		b. Steering wheel	Turn	Turn full left or full right, to expose shock absorber to be removed
		c. Key switch	Turn off	To stop engine
2	Shock absorber	a. Two locknuts (1) and washers (2)	Remove	
		b. Shock absorber (3)	Remove	Loosen with soft hammer, if necessary; pull free of shock absorber mounting studs
		c. Two spacers (4)	Remove	
		d. Two locknuts (5)	Remove	
		e. Rubber block (8), two cap-screws (6), and washers (7)	Remove	Separate cap-screws (6) and washers (7) from rubber block (8)
		f. Four rubber bushings (9)	Remove	From ends of shock absorber (3)

2-64. SHOCK ABSORBERS MAINTENANCE (CONT)

KEY

- 1. Locknuts (2)
- 2. Washers (2)
- 3. Shock absorber
- 4. Spacers (2)
- 5. Locknuts (2)
- 6. Capscrews (2)
- 7. Washers (2)
- 8. Rubber block
- 9. Rubber bushings (4)

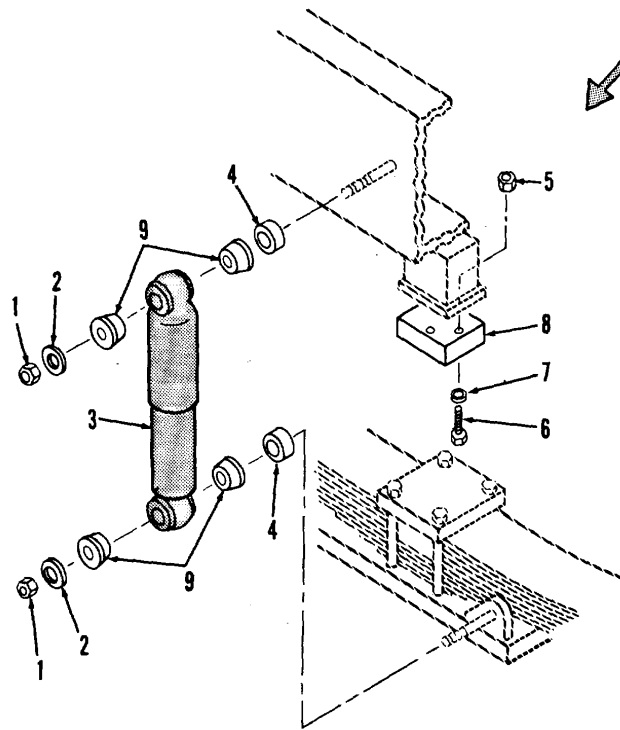
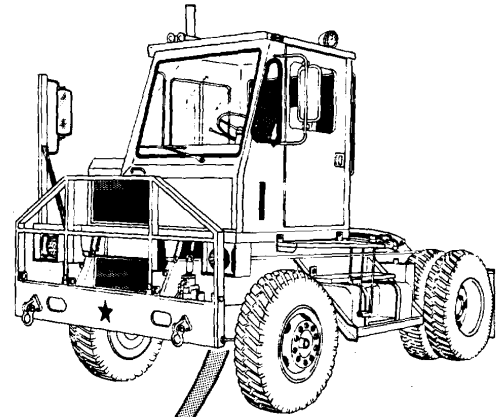

2-696

2-64. SHOCK ABSORBERS MAINTENANCE (CONT)

STEP	LOCATION	ITEM	ACTION	REMARKS
CLEANING				
3		a. Rubber block (8)	Clean	Wipe with clean cloth moistened with mild detergent solution; rinse with clear water

WARNING

Dry cleaning solvent (P-D-680), used to clean parts is toxic and flammable. Wear protective goggles and gloves and use only in a well ventilated area. Avoid contact with skin, eyes, and clothes and don't breathe vapors. Do not use near open flame or excessive heat and don't smoke when using it. Failure to do so could cause serious injury. If you become dizzy while using cleaning solvent, get fresh air and medical attention immediately. If contact with skin or clothes is made, flush with large amounts of water. If contact with eyes is made, wash eyes with water and seek medical aid immediately.

Compressed air must not exceed 30 psi. Wear safety glasses when drying parts with compressed air. Failure to do so could cause serious injury to eyes and possible blindness. If you hurt your eyes or if a foreign object is blown into your eyes, seek medical attention immediately.

		b. Shock absorber (3) and all other parts	Clean	Wipe with clean cloth moistened with cleaning solvent P-D-680; dry with compressed air
--	--	---	-------	--

INSPECTION

4		a. Shock absorber (3)	Inspect	Replace if cracked, broken, distorted, leaking, or otherwise damaged.
Replace		b. Rubber block (8) and bushings (9)	Inspect	as a pair only Replace if cracked, broken, or deteriorated
		c. All other parts	Inspect	Replace if cracked, broken, distorted, or threads damaged

2-64. SHOCK ABSORBERS MAINTENANCE (CONT)

STEP	LOCATION	ITEM	ACTION	REMARKS
INSTALLATION				
5	Frame rail	a. Rubber block (8)	Position	
		b. Two capscrews (6), washers (7), and locknuts (5)	Install and tighten	To secure rubber block (8)
		c. Two spacers (4)	Install	
		d. Four rubber bushings (9)	Install	Push in each end of shock absorber (3)
		e. Shock absorber (3)	Install	Grease studs lightly before installation; tap on with soft hammer as necessary
		f. Two washers (2) and locknuts (1)	Install and tighten	

2-65. BODY AND CAB MAINTENANCE

- a. Side Step.

This task covers:

- a. Removal
- b. Cleaning
- c. Inspection
- d. Installation/Replacement

INITIAL SETUP:

Tools

No. 1 Common Organizational Maintenance Tool Kit

Socket wrench set, 3/8 inch drive
Welding shop equipment

Personnel Required

Two Wheel Vehicle Mechanics MOS 63B

Equipment Condition

Paragraph Condition Description

Materials/Parts

Cleaning solvent Item 1, Appendix C
Clean cloths Item 2, Appendix C

Vehicle parked on level surface, engine off, and parking brake applied.

KEY

- 1. Capscrews (2)
- 2. Locknuts (2)
- 3. Washers (2)
- 4. Capscrew
- 5. Locknut
- 6. Washers (2)
- 7. Capscrews (2)
- 8. Locknuts (2)
- 9. Washers (4)
- 10. Side step

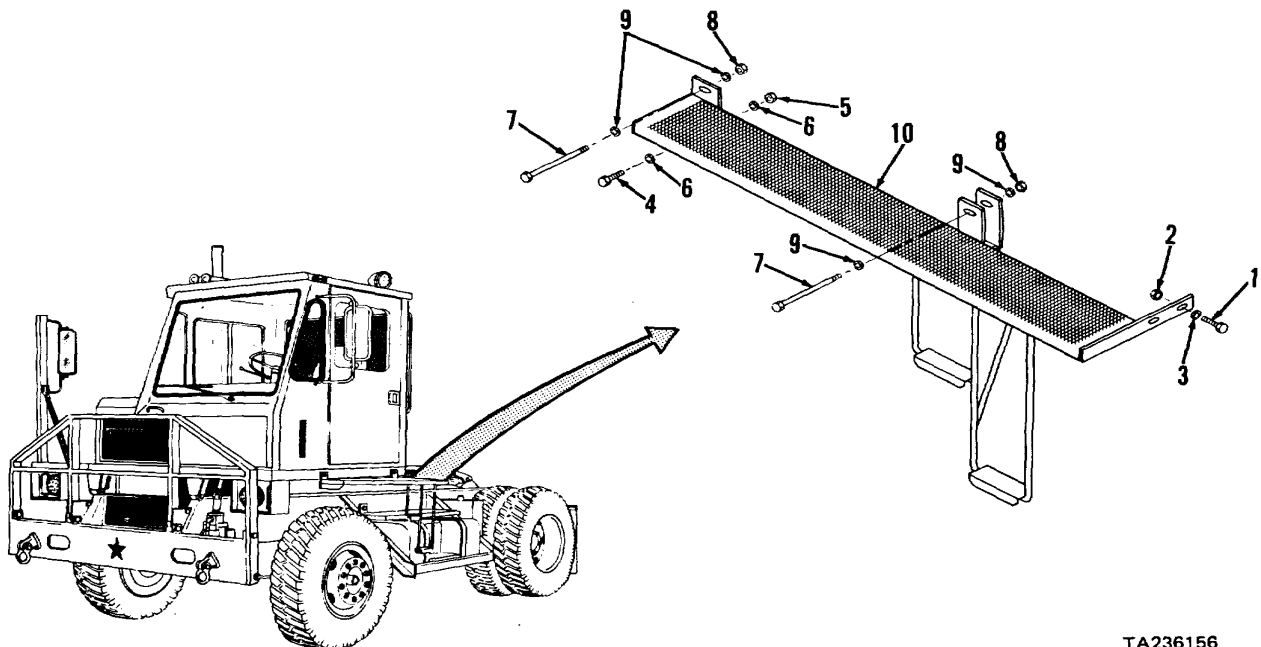

TA236156

2-65. BODY AND CAB MAINTENANCE (CONT)

a. Side Step (cont).

STEP	LOCATION	ITEM	ACTION	REMARKS
REMOVAL				
1	Cab deck	a. Two capscrews (1), lock-nuts (2), and washers (3)	Remove	
		b. Capscrew (4), locknut (5), and two washers (6)	Remove	
		c. Two capscrews (7), lock-nuts (8), and four washers (9)	Remove	Support side step (10)
		d. Side step (10)	Remove	From cab deck
CLEANING				

WARNING

Dry cleaning solvent (P-D-680), used to clean parts is toxic and flammable. Wear protective goggles and gloves and use only in a well ventilated area. Avoid contact with skin, eyes, and clothes and don't breathe vapors. Do not use near open flame or excessive heat and don't smoke when using it. Failure to do so could cause serious injury. If you become dizzy while using cleaning solvent, get fresh air and medical attention immediately. If contact with skin or clothes is made, flush with large amounts of water. If contact with eyes is made, wash eyes with water and seek medical aid immediately.

Compressed air must not exceed 30 psi. Wear safety glasses when drying parts with compressed air. Failure to do so could cause serious injury to eyes and possible blindness. If you hurt your eyes or if a foreign object is blown into your eyes, seek medical attention immediately.

2	All parts		Clean	Use cleaning solvent P-D-680; dry using clean cloths
---	-----------	--	-------	--

2-65. BODY AND CAB MAINTENANCE (CONT)

a. Side Step (cont).

STEP	LOCATION	ITEM	ACTION	REMARKS
INSPECTION				
3		a. Side step (10)	Inspect for: broken welds cracks dents	Repair broken welds by welding; replace if other defects observed
		b. All other parts	Inspect for: damaged threads twisted bent	Replace if defects observed
INSTALLATION/REPLACEMENT				
4	Cab deck	a. Side step (10)	Position	On cab deck. Align mounting holes
		b. Four washers (9), two cap-screws (7), and locknuts (8)	Install	Do not tighten
		c. Two washers (6), capscrew (4), and locknut (5)	Install	Do not tighten
		d. Two washers (3), cap-screws (1), and locknuts (2)	Install and tighten	
		e. Four capscrews (4 and 7) and locknuts (5 and 8)	Tighten	

2-65. BODY AND CAB MAINTENANCE (CONT)

- b. Mud Flaps and Dock Bumpers.

This task covers:

- a. Removal
- b. Cleaning
- c. Inspection
- d. Installation/Replacement

INITIAL SETUP:

Tools

- No. 1 Common Organizational Maintenance Tool Kit
- Socket wrench set, 1/2 inch drive
- Screw threading set

Personnel Required

Wheel Vehicle Mechanic MOS 63B

Equipment Condition

Paragraph	Condition Description
-----------	-----------------------

Materials/Parts

- | | |
|------------------|---------------------|
| Cleaning solvent | Item 1, Appendix C |
| Clean cloths | Item 2, Appendix C |
| Detergent | Item 27, Appendix C |

Vehicle parked on level surface, engine off, and parking brake applied.

KEY

1. Capscrews (4)
2. Washers (4)
3. Locknuts (4)
4. Mud flap
5. Capscrews (2)
6. Washers (2)
7. Dock bumper

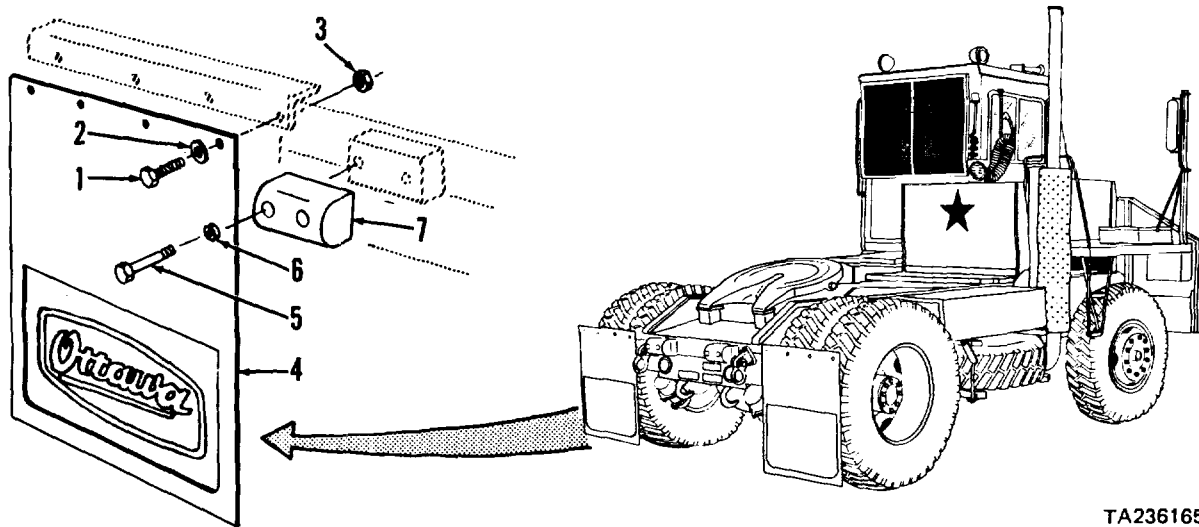

TA236165

2-65. BODY AND CAB MAINTENANCE (CONT)

b. Mud Flaps and Dock Bumpers (cont).

STEP	LOCATION	ITEM	ACTION	REMARKS
------	----------	------	--------	---------

REMOVAL

1	Rear of vehicle, left or right side	a. Four capscrews (1), washers (2), and lock-nuts (3)	Remove	Support mud flap (4)
		b. Mud flap (4)	Remove	

NOTE

Perform the above to remove the remaining mud flap.

2	Rear of vehicle, left or right side	a. Two capscrews (5) and washers (6)	Remove	Support dock bumper (7)
		b. Dock bumper (7)	Remove	

NOTE

Perform the above to remove the remaining dock bumper.

CLEANING

3		a. Mud flap (4) and dock bumper (7)	Clean	Use detergent and clean cloth; dry using clean cloths
---	--	-------------------------------------	-------	---

WARNING

Dry cleaning solvent (P-D-680), used to clean parts is toxic and flammable. Wear protective goggles and gloves and use only in a well ventilated area. Avoid contact with skin, eyes, and clothes and don't breathe vapors. Do not use near open flame or excessive heat and don't smoke when using it. Failure to do so could cause serious injury. If you become dizzy while using cleaning solvent, get fresh air and medical attention immediately. If contact with skin or clothes is made, flush with large amounts of water. If contact with eyes is made, wash eyes with water and seek medical aid immediately.

		b. All other parts	Clean	Use cleaning solvent P-D-680; dry using clean cloths
--	--	--------------------	-------	--

2-65. BODY AND CAB MAINTENANCE (CONT)

b. Mud Flaps and Dock Bumpers (cont).

STEP	LOCATION	ITEM	ACTION	REMARKS
INSPECTION				
4		a. Mud flap (4)	Inspect for: cracks tears damage	Replace if defective
		b. Dock bumper (7)	Inspect for: cracks gouges	Replace if defective
		c. All other parts	Inspect for: deformation thread damage	Replace if defective
		d. Dock bumper mounting holes (located on frame)	Inspect for: thread damage	If threads are damaged, chase using 1/2-13 tap

INSTALLATION/REPLACEMENT

5	Rear of vehicle, left or right side	a. Mud flap (4) b. Four capscrews (1), washers (2), and locknuts (3)	Position Install and tighten	
---	-------------------------------------	---	------------------------------------	--

NOTE

Perform the above to install the remaining mud flap.

6	Rear of vehicle, left or right side washers (6)	a. Dock bumper (7) b. Two capscrews (5) and	Position Install and tighten	
---	---	--	------------------------------------	--

NOTE

Perform the above to install the remaining dock bumper.

2-65. BODY AND CAB MAINTENANCE (CONT)

c. Rear Platform.

This task covers:

- a. Removal
- b. Cleaning
- c. Inspection/Repair
- d. Installation

INITIAL SETUP:

Tools

No. 1 Common Organizational Maintenance Tool Kit

- Safety glasses
- Wire brush
- Combination wrench set

Personnel Required

Two Wheel Vehicle Mechanics MOS 63B

Equipment Condition

Paragraph Condition Description

Parked on level surface; parking brake applied; engine off.

Materials/Parts

Cleaning solvent Item 1, Appendix C
Clean cloths Item 2, Appendix C

KEY

- 1. Toggle clamp
- 2. Hook
- 3. Rear platform
- 4. Eyebolt
- 5. Locknuts (2)
- 6. Washers (2)
- 7. Capscrews (2)
- 8. Nut
- 9. Nut
- 11. Locknut
- 10. Locknut

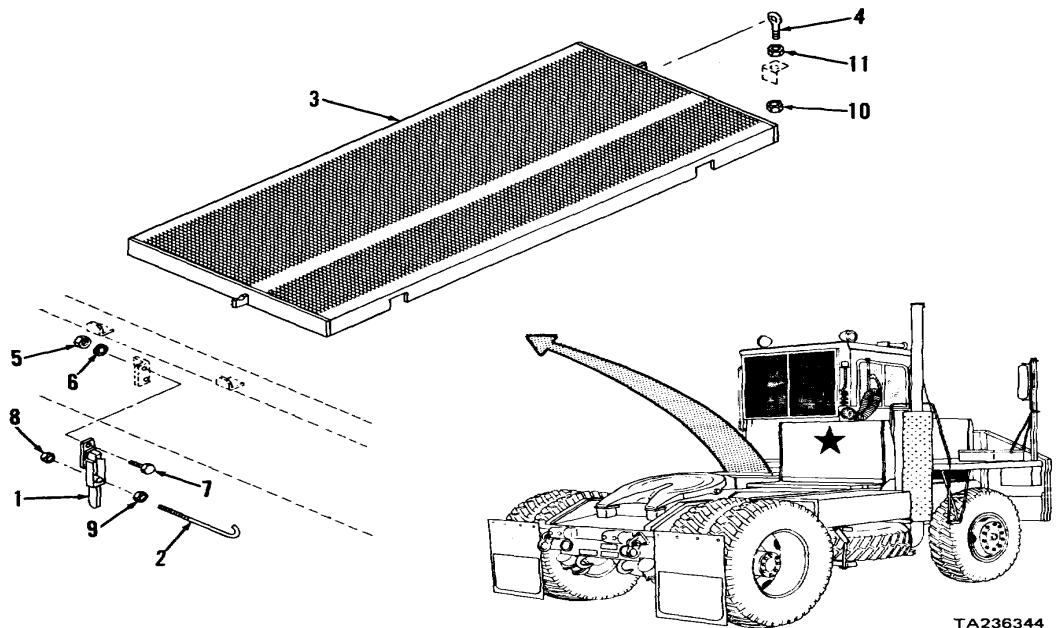

2-65. BODY AND CAB MAINTENANCE (CONT)

c. Rear Platform (cont).

STEP	LOCATION	ITEM	ACTION	REMARKS
REMOVAL				
1	Tractor, rear	a. Toggle clamp (1) handle	Raise	To release hook (2)
		b. Hook (2)	Slide	Slide toggle clamp hook (2) away from rear platform holddown
		c. Rear platform (3)	Remove	Slide left-hand side rearward and lift up to disengage from eyebolt (4). Remove from tractor with assistant
2	Left frame rail	a. Two locknuts (5), washers (6), and capscrews (7)	Remove	
		b. Toggle clamp (1)	Remove	
		c. Nut (8)	Remove	
		d. Hook (2) with nut (9)	Remove	From toggle clamp (1)
		e. Nut (9)	Separate	From hook (2)
3	Right frame rail with nut (11)	a. Nut (10)	Remove	
		b. Eyebolt (4)	Remove	
		c. Nut (11)	Separate	From eyebolt (4)

CLEANING

WARNING

Dry cleaning solvent (P-D-680), used to clean parts is toxic and flammable. Wear protective goggles and gloves and use only in a well ventilated area. Avoid contact with skin, eyes, and clothes and don't breathe vapors. Do not use near open flame or excessive heat and don't smoke when using it. Failure to do so could cause serious injury. If you become dizzy while using cleaning solvent, get fresh air and medical attention immediately. If contact with skin or clothes is made, flush with large amounts of water. If contact with eyes is made, wash eyes with water and seek medical aid immediately.

2-65. BODY AND CAB MAINTENANCE (CONT)

c. Rear Platform (cont).

STEP	LOCATION	ITEM	ACTION	REMARKS
------	----------	------	--------	---------

CLEANING (cont)

WARNING

Compressed air must not exceed 30 psi. Wear safety glasses when drying parts with compressed air. Failure to do so could cause serious injury to eyes and possible blindness. If you hurt your eyes or if a foreign object is blown into your eyes, seek medical attention immediately.

4		All parts	Clean	Use cleaning solvent P-D-680 and stiff bristled brush; dry thoroughly with compressed air
---	--	-----------	-------	---

INSPECTION/REPAIR

5		a. Rear platform (3)	Inspect	Repair broken welds and cracks by welding. Replace a rear platform beyond economical repair
		b. All other parts	Inspect	Replace if cracked, broken, distorted, or threads damaged

INSTALLATION

6	Right frame rail	a. Locknut (11)	Install	Screw onto eyebolt (4) fully
		b. Eyebolt (4)	Install	
		c. Locknut (10)	Install	Screw onto end of eyebolt (4). Do not tighten at this time
7	Left frame rail	a. Nut (9)	Install	Screw onto hook (2) fully
		b. Hook (2)	Position	In toggle clamp (1)
		c. Nut (8)	Install	Do not tighten at this time
		d. Toggle clamp (1)	Position	Align mounting holes
		e. Two capscrews (7), washers (6), and locknuts (5)	Install and tighten	

2-65. BODY AND CAB MAINTENANCE (CONT)

c. Rear Platform (cont).

STEP	LOCATION	ITEM	ACTION	REMARKS
INSTALLATION (cont)				
8	Tractor, rear	a. Rear platform (3)	Install	Engage right platform hook in eyebolt (4), lower left side of platform, and push left side of platform forward
		b. Eyebolt (4)	Position	So eyebolt rests on top of rear platform holddown
		c. Locknuts (10 and 11)	Tighten	To secure eyebolt (4)
		d. Hook (9)	Position	Onto rear platform holddown
		e. Nuts (8 and 9)	Adjust and tighten	So lowered toggle clamp (1) handle locks over-center
		f. Toggle clamp (1) handle	Lower	Secures rear platform (3)

2-65. BODY AND CAB MAINTENANCE (CONT)

d. Rear Cab Guard and Heat Shield.

This task covers:

- a. Removal
- b. Cleaning

- c. Inspection/Repair
- d. Installation

INITIAL SETUP:

Tools

No. 1 Common Organizational Maintenance
Tool Kit
 Socket wrench set, 1/2 inch drive
 Open end wrench set
 Safety glasses
Chain hoist
Welding shop equipment
Air compressor
10 gauge metal, 2 inches by 11 inches

2-53a

2-65c

2-13c

2-15b(2)

2-41e

2-58b

Materials/Parts

Cleaning solvent Item 1, Appendix C
Clean cloths Item 2, Appendix C

2-58c

2-31g

3-24i

Personnel Required

Wheel Vehicle Mechanic MOS 63B

2-53b

Equipment Condition

Paragraph Condition Description

 Vehicle parked on level
 surface, engine off, and
 parking brake applied.

2-13b(1)

2-14b

Trailer brake lines and
couplings disconnected and
removed from rear cab guard.
Rear platform removed.
Primary and secondary fuel
filters removed.
Coolant filter removed.
External transmission oil
filter removed.
Power steering hose clamp
removed.
Power steering reservoir
removed.
Rear flood light removed.
Tractor protection valve
removed.
Hose tender removed.
Fuel tank guard removed.
Exhaust stack, muffler, and
brackets removed (rear cab
guard supported on right side)

STEP	LOCATION	ITEM	ACTION	REMARKS
------	----------	------	--------	---------

REMOVAL

1	Rear cab guard (5), top	Chain hoist	Attach	To top of rear cab guard (5); take up chain slack
---	-------------------------	-------------	--------	---

WARNING

Be sure chain hoist is securely fastened to rear cab guard (5) before performing the following step. Failure to do so could cause serious injury due to rear cab guard falling on you. If you are injured, obtain medical aid immediately.

2-65. BODY AND CAB MAINTENANCE (CONT)

d. Rear Cab Guard and Heat Shield (cont).

KEY

- 1. Locknuts (4)
- 2. Washers (4)
- 3. Capscrews (2)
- 4. Capscrews (2)
- 5. Rear cab guard
- 6. Right hand upper shim
- 7. Right hand lower shim
- 8. Left hand upper shim
- 9. Left hand lower shim
- 10. Nuts (2)
- 11. Capscrews (2)
- 12. Lock washers (2)
- 13. Heat shield

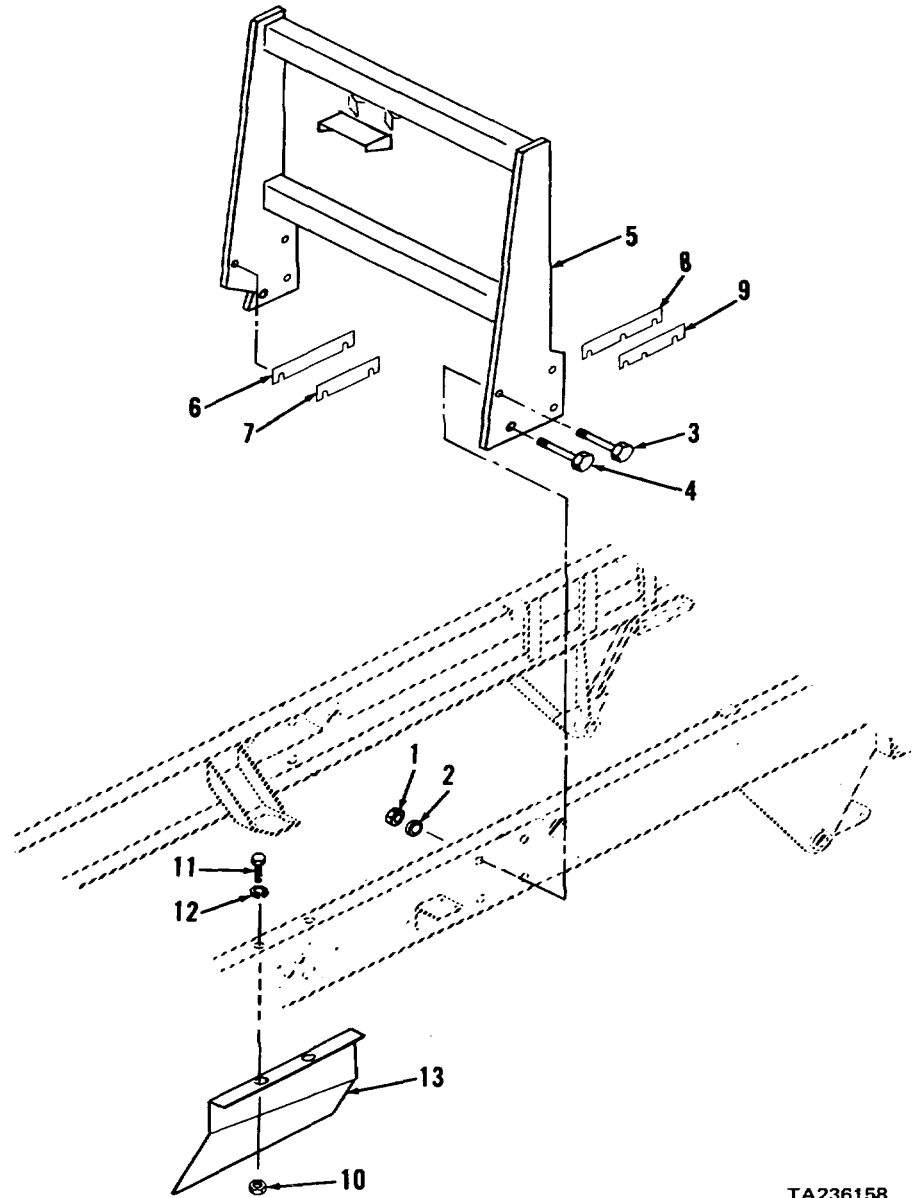

TA236158

2-65. BODY AND CAB MAINTENANCE (CONT)

d. Rear Cab Guard and Heat Shield (cont).

STEP	LOCATION	ITEM	ACTION	REMARKS
REMOVAL (cont)				
2	Rear cab guard (5), left side	a. Four locknuts (1) and washers (2)	Remove	
		b. Two capscrews (3) and two capscrews (4)	Remove	
		c. Rear cab guard (5)	Remove	Lift using chain hoist

NOTE

Shims (6, 7, 8, and 9) will fall on ground when rear cab guard (5) is pulled from frame rails.

3	Cab tilt pump	Cab		Tilt 45 degrees
4	Frame, left side, near exhaust manifold	a. Two nuts (10), capscrews (11), and lock washers (12)	Remove	Support heat shield (13)
		b. Heat shield (13)	Remove	

CLEANING

WARNING

Dry cleaning solvent (P-D-680), used to clean parts is toxic and flammable. Wear protective goggles and gloves and use only in a well ventilated area. Avoid contact with skin, eyes, and clothes and don't breathe vapors. Do not use near open flame or excessive heat and don't smoke when using it. Failure to do so could cause serious injury. If you become dizzy while using cleaning solvent, get fresh air and medical attention immediately. If contact with skin or clothes is made, flush with large amounts of water. If contact with eyes is made, wash eyes with water and seek medical aid immediately.

2-45. BODY AND CAB MAINTENANCE (CONT)

- d. Rear Cab Guard and Heat Shield (cont).

STEP	LOCATION	ITEM	ACTION	REMARKS
------	----------	------	--------	---------

CLEANING (cont)

WARNING

Compressed air must not exceed 30 psi. Wear safety glasses when drying parts with compressed air. Failure to do so could cause serious injury to eyes and possible blindness. If you hurt your eyes or if a foreign object is blown into your eyes, seek medical attention immediately.

5		All parts	Clean	Use cleaning solvent P-D-680; dry using compressed air
---	--	-----------	-------	--

INSPECTION/REPAIR

6		a. Shims (6, 7, 8, and 9) and heat shield (13)	Inspect for: cracks dents bent condition	Replace if defects are observed
		b. Rear cab guard (5)	Inspect for: broken welds cracks breaks bent condition	Repair broken welds by welding; replace if other defects are observed
		c. All other parts	Inspect for: deformation damaged threads	Replace if any defects are observed

INSTALLATION

7	Frame, left side, near exhaust manifold	a. Heat shield (13) b. Two capscrews (11), lock washers (12) and nuts (10)	Position Install and tighten	On frame
8	Cab tilt pump	Cab	Lower	To normal operating position

2-65. BODY AND CAB MAINTENANCE (CONT)

d. Rear Cab Guard and Heat Shield (cont).

STEP	LOCATION	ITEM	ACTION	REMARKS
INSTALLATION (cont)				
9	Rear cab guard (5), top	Chain hoist	Attach	To top of rear cab guard (5); take up chain slack

WARNING

Be sure chain hoist is securely fastened to rear cab guard (5) before performing the following step. Failure to do so could cause serious injury due to rear cab guard falling on you. If you are injured, obtain medical aid immediately.

10	Frame, directly behind cab	Rear cab guard (5)	Position	Use chain hoist; align mounting holes in frame with holes in rear cab guard (5)
11	Rear cab guard (5), left side	a. Two capscrews (4)	Install	Be sure slots in shim (9) are over capscrews (4). If necessary, use a piece of 10 gauge metal to position
		b. Left hand lower shim (9)	Install	

NOTE

Left hand lower shim (9) is 9 inches long.

		c. Two capscrews (3)	Install	
		d. Left hand upper shim (8)	Install	Be sure slots in shim (8) are over capscrews (3). If necessary, use a piece of 10 gauge metal to position

NOTE

Left hand upper shim (8) is 11 inches long and has 3 slots.

		e. Four washers (2) and lock-nuts (1)	Install	Do not tighten
--	--	---------------------------------------	---------	----------------

2-65. BODY AND CAB MAINTENANCE (CONT)

d. Rear Cab Guard and Heat Shield (cont).

STEP	LOCATION	ITEM	ACTION	REMARKS		
INSTALLATION (cont)						
12	Rear cab guard (5), right side	a. Muffler bracket	Position	Against rear cab guard with mounting holes aligned; para 2-14b		
		b. Two lower cap-screws	Install	Through muffler bracket, rear cab guard (5), and frame rail (para 2-14b). Do not tighten		
NOTE						
Right hand lower shim (7) is 8-1/2 inches long.						
12	Rear cab guard (5), right side	c. Shim (7)	Install	Be sure slots in shim (7) fit over capscrews. If necessary, use a piece of 10 gauge metal to position		
		d. Two washers and locknuts	Install	On lower capscrews; para 2-14b. Do not tighten		
		e. Two upper cap-screws	Install	Para 2-14b. Do not tighten		
		f. Shim (6)	Install	Be sure slots in shim (6) fit over capscrews. If necessary, use a piece of 10 gauge metal to position		
		g. Two washers and locknuts	Install and tighten	On upper capscrews; para 2-14b		
		h. Two lower cap-screws and locknuts	Tighten	Para 2-14b		
		13	Rear cab guard (5), left hand side	Four capscrews (3 and 4) and locknuts (1)	Tighten	
		14	Rear cab guard (5), top	Chain hoist	Remove	
15	Tractor, right hand side	Muffler and exhaust stack	Install	Para 2-14b		

2-65. BODY AND CAB MAINTENANCE (CONT)

d. Rear Cab Guard and Heat Shield (cont).

STEP	LOCATION	ITEM	ACTION	REMARKS
INSTALLATION (cont)				
16	Rear cab guard (5)	a. Rear flood light	Install	Para 2-31g
		b. Hose tender	Install	Para 2-53b
		c. Tractor protection valve	Install	Para 3-24i
		d. Trailer brake lines and couplings	Install	Para 2-53a
		e. Power steering reservoir	Install	Para 2-58c
		f. Power steering hose clamp	Install	Para 2-58b
		g. External transmission oil filter	Install	Para 2-41e
		h. Primary and secondary fuel filters	Install	Para 2-13c
		i. Coolant filter	Install	Para 2-15b(2)
17	Fuel tank	Fuel tank guard	Install	Para 2-13b(l)
18	Tractor frame	Rear platform	Install	Para 2-65c

2-65. BODY AND CAB MAINTENANCE (CONT)

e. Bumper and Grille Guard.

This task covers:

- a. Removal
- b. Cleaning
- c. Inspection
- d. Installation/Replacement

INITIAL SETUP:

Tools

No. 1 Common Organizational Maintenance Tool Kit

- Socket wrench set, 1/2 inch drive
- Open end wrench set
- Safety glasses

Pliers

- Welding shop equipment
- Plastic hammer
- Chain hoist
- Air compressor

Materials/Parts

- Cleaning solvent Item 1, Appendix C
- Clean cloths Item 2, Appendix C

Personnel Required

Wheel Vehicle Mechanic MOS 63B

Equipment Condition

Paragraph	Condition Description
2-63b	Vehicle parked on level surface, engine off, and parking brake applied. Tow shackles removed from bumper.
2-73f	Junction box removed.

KEY

1. Pin retainers (2)
2. Pins (2)
3. Pin retainers (2)
4. Pins (2)
5. Capscrews (2)
6. Nuts (2)
7. Washers (2)
8. Capscrews (2)
9. Nuts (2)
10. Washers (2)
11. Grille guard
12. Capscrews (4)
13. Locknuts (4)
14. Washers (4)
15. Bumper
16. Cotter pins (4)

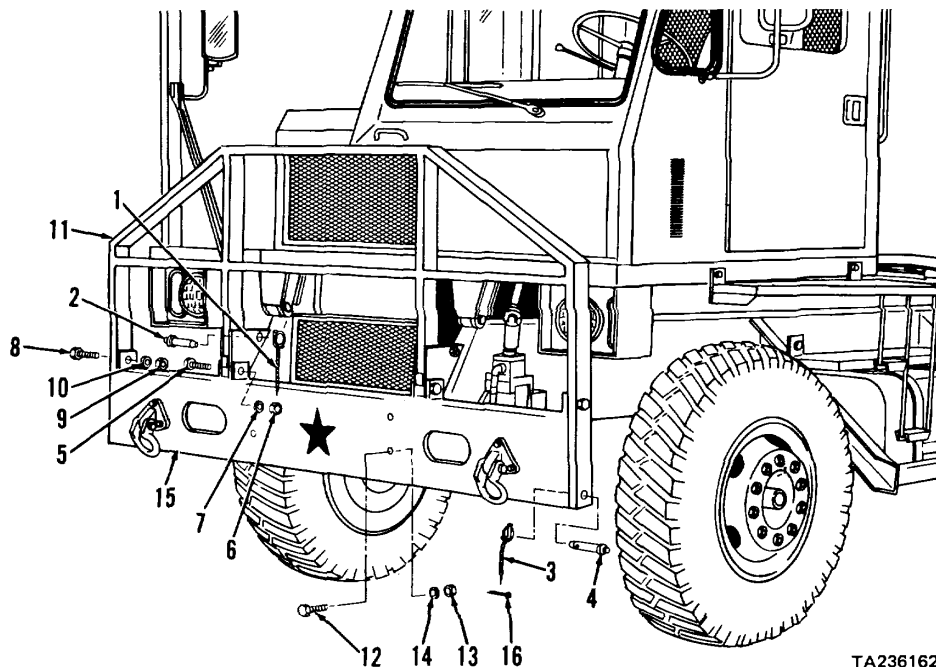

2-65. BODY AND CAB MAINTENANCE (CONT)

e. Bumper and Grille Guard (cont).

STEP	LOCATION	ITEM	ACTION	REMARKS
REMOVAL				
1	Front of vehicle, grille guard (11)	a. Chain hoist	Attach	To grille guard (11); take up chain slack
		b. Four cotter pins (16)	Remove	From pin retainers (1 and 3)
		c. Two pin retainers (1)	Remove	From pin (2)
		d. Two pins (2)	Remove	Use plastic hammer if necessary
		e. Two pin retainers (3)	Remove	From pin (4)
		f. Two pins (4)	Remove	Use plastic hammer if necessary
		g. Two capscrews (5), nuts (6), and washers (7)	Remove	

WARNING

Be sure chain hoist is securely fastened to grille guard before performing the following step. Failure to do so could cause serious injury by grille guard falling on you. If you are injured by falling equipment, obtain medical aid immediately.

		h. Two capscrews (8), nuts (9), and washers (10)	Remove	
		i. Grille guard (11)	Remove	From vehicle
2	Front of vehicle; bumper (15)	a. Chain hoist	Attach	To bumper (15); take up chain slack

WARNING

Be sure chain hoist is securely fastened to bumper before performing the following step. Failure to do so could cause serious injury by bumper falling on you. If you are injured by falling equipment, obtain medical aid immediately.

2-65. BODY AND CAB MAINTENANCE (CONT)

e. Bumper and Grille Guard (cont).

STEP	LOCATION	ITEM	ACTION	REMARKS
REMOVAL (cont)				
2 (cont)		b. Four capscrews (12), lock-nuts (13), and washers (14)	Remove	
		c. Bumper (15)	Remove	From vehicle

CLEANING

WARNING

Dry cleaning solvent (P-D-680), used to clean parts is toxic and flammable. Wear protective goggles and gloves and use only in a well ventilated area. Avoid contact with skin, eyes, and clothes and don't breathe vapors. Do not use near open flame or excessive heat and don't smoke when using it. Failure to do so could cause serious injury. If you become dizzy while using cleaning solvent, get fresh air and medical attention immediately. If contact with skin or clothes is made, flush with large amounts of water. If contact with eyes is made, wash eyes with water and seek medical aid immediately.

Compressed air must not exceed 30 psi. Wear safety glasses when drying parts with compressed air. Failure to do so could cause serious injury to eyes and possible blindness. If you hurt your eyes or if a foreign object is blown into your eyes, seek medical attention immediately.

3		All parts	Clean	Use cleaning solvent P-D-680; dry using compressed air
INSPECTION				
4		a. Pin retainers (1 and 3)	Inspect for: cracks wear damage bent condition	Replace if defective

2-65. BODY AND CAB MAINTENANCE (CONT)

e. Bumper and Grille Guard (cont).

STEP	LOCATION	ITEM	ACTION	REMARKS
INSPECTION (cont)				
4 (cont)		b. Pins (2 and 4)	Inspect for: cracks bent or twisted condition	Replace if defective
		c. Grille guard (11)	Inspect for: broken welds cracks dents	Repair broken welds by welding; replace if other defects are observed
		d. Bumper (15)	Inspect for: broken welds cracks	Repair broken welds by welding; replace if other defects are observed
		e. All other parts	Inspect for thread damage deformation	Replace if defective

INSTALLATION / REPLACEMENT

5	Front of vehicle	a. Chain hoist	Attach	To bumper (15)
---	---------------------	----------------	--------	----------------

WARNING

Be sure chain hoist is securely fastened to bumper (15) before performing steps 5b and 5c below. Failure to do so could cause serious injury due to bumper falling on you. If you are injured by falling equipment, obtain medical aid immediately.

		b. Bumper (15)	Position	Use chain hoist and position on front of vehicle
		c. Four capscrews (12), washers (14), and locknuts (13)	Install and tighten	
		d. Chain hoist	Remove	From bumper (15)

2-65. BODY AND CAB MAINTENANCE (CONT)

e. Bumper and Grille Guard (cont).

STEP	LOCATION	ITEM	ACTION	REMARKS
INSTALLATION/REPLACEMENT (cont)				
6	Bumper (15)	a. Chain hoist	Attach	To grille guard (11)
<u>WARNING</u>				
Be sure chain hoist is securely fastened to grille guard before performing steps 6b thru 6d below. Failure to do so could cause serious injury due to grille guard falling on you. If you are injured by falling equipment, obtain medical aid immediately.				
		b. Grille guard (11)	Position	Use chain hoist and position on bumper (15)
		c. Two capscrews (8), washers (10), and nuts (9)	Install and tighten	
		d. Two capscrews (5), washers (7), and nuts (6)	Install and tighten	
		e. Chain hoist	Disconnect	From grille guard (11)
		f. Four pins (2 and 4)	Install	
		g. Four pin retainers (1 and 3)	Install	
		h. Four cotter pins (16)	Install and spread	Secures pin retainers (1 and 3)
7	Bumper	a. Junction box	Install	Para 2-73f
(15)		b. Tow shackles	Install	Para 2-63b

2-65. BODY AND CAB MAINTENANCE (CONT)

f. Hood and Latch and Rear Enclosure.

This task covers:

- a. Removal
- b. Cleaning
- d. Inspection
- c. Installation /Repair
- e. Adjustment

INITIAL SETUP:

Tools

No. 1 Common Organizational Maintenance

Tool Kit

Socket wrench set, 3/8 inch drive

Open end wrench set

Scratch wire brush

Cross tip screwdriver set

Safety glasses

Retaining ring pliers

Air compressor

Materials/Parts

Cleaning solvent Item 1, Appendix C

Clean cloths Item 2, Appendix C

Detergent Item 27, Appendix C

Personnel Required

Wheel Vehicle Mechanic MOS 63B

Equipment Condition

Paragraph Condition Description

2-69c

2-30

Vehicle parked on level surface, engine off, and parking brake applied.

Windshield washer pump and reservoir removed.

12-volt and 24-volt receptacles removed from rear hood enclosure.

STEP	LOCATION	ITEM	ACTION	REMARKS
------	----------	------	--------	---------

REMOVAL

1	Cab deck, hood (4)	a. Two latches (11)	Unlatch	Pull up and disengage from latch brackets (7)
		b. Hood (4)	Open	Raise up and rest against side of cab
		c. Seven capscrews (1), locknuts (2), and washers (3)	Remove	
		d. Hood (4)	Remove	

NOTE

Don't perform steps 1e and 1f below unless inspection indicates removal/replacement of latch assemblies (7 thru 11 and 14) is necessary.

e. Four screws (5) and locknuts (6)	Remove	Support latch brackets (7)
f. Two latch brackets (7)	Remove	

2-65. BODY AND CAB MAINTENANCE (CONT)

f. Hood and Latch and Rear Enclosure (cont).

KEY

- | | |
|-----------------------|------------------------|
| 1. Capscrews (7) | 10. Shafts (2) |
| 2. Locknuts (7) | 11. Latches (2) |
| 3. Washers (7) | 12. Screws (4) |
| 4. Hood | 13. Locknuts (4) |
| 5. Screws (4) | 14. Pivot brackets (2) |
| 6. Locknuts (4) | 15. Screws (7) |
| 7. Latch brackets (2) | 16. Locknuts (7) |
| 8. Cotter pins (2) | 17. Washers (7) |
| 9. Washers (2) | 18. Screw, 1 inch long |

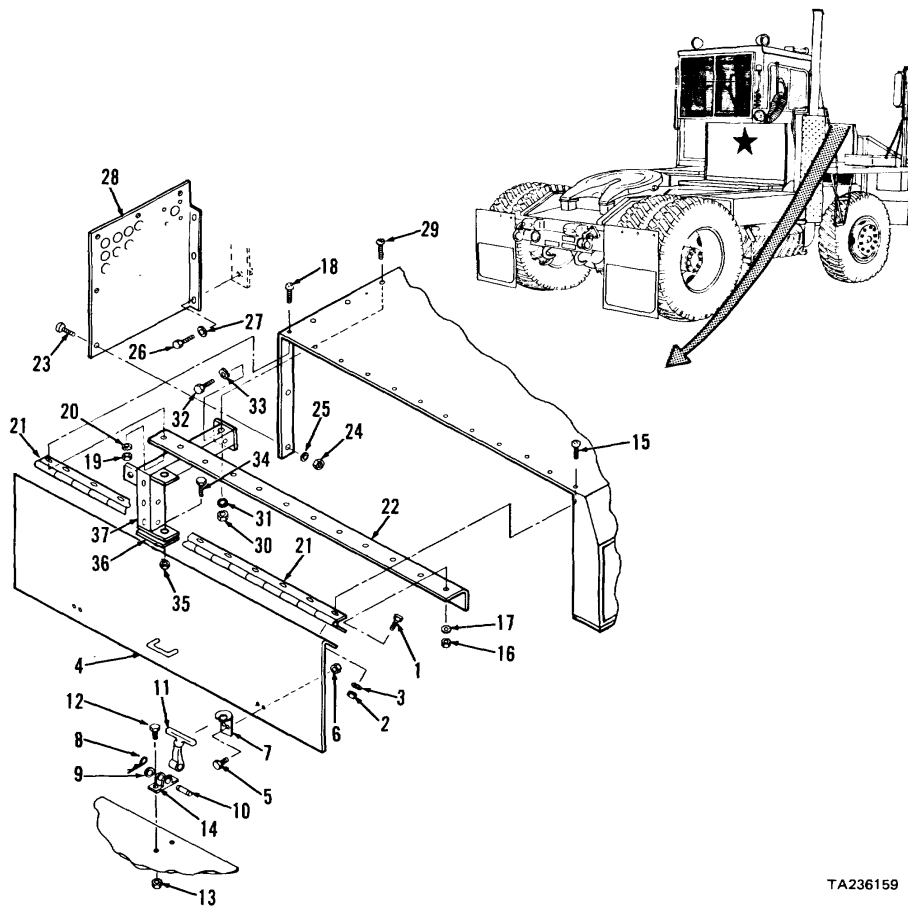

- | |
|---------------------------------|
| 19. Locknut |
| 20. Washer |
| 21. Hinge |
| 22. Angle bracket |
| 23. Screws (5) |
| 24. Locknuts (5) |
| 25. Washers (5) |
| 26. Capscrews (3) |
| 27. Washers (3) |
| 28. Rear engine enclosure panel |
| 29. Screws (3) |
| 30. Locknuts (3) |
| 31. Washers (3) |
| 32. Capscrews (2) |
| 33. Washers (2) |
| 34. Capscrew |
| 35. Nut |
| 36. Cab mount |
| 37. Hood support |

TA236159

2-65. BODY AND CAB MAINTENANCE (CONT)

f. Hood and Latch and Rear Enclosure (cont).

STEP	LOCATION	ITEM	ACTION	REMARKS
REMOVAL (cont)				
NOTE				
Don't perform step 2 below unless inspection indicates replacement of these parts (8 thru 14) is necessary.				
2	Cab deck weldment	a. Two cotter pins (8) and washers (9)	Remove	
		b. Two shafts (10)	Remove	
		c. Two latches (11)	Remove	
		d. Four screws (12) and locknuts (13)	Remove	
		e. Two pivot brackets (14)	Remove	
3	Hood, top	a. Seven screws (15), lock-nuts (16), and washers (17)	Remove	
		b. Screw (18), locknut (19), and washer (20)	Remove	Support hinge (21) and angle bracket (22)
		c. Hinge (21) and angle bracket (22)	Remove	
4	Hood, rear	a. Five screws (23), lock-nuts (24), and washers (25)	Remove	
		b. Three capscrews (26) and washers (27)	Remove	Support rear engine enclosure panel (28)
		c. Rear engine enclosure panel (28)	Remove	

2-65. BODY AND CAB MAINTENANCE (CONT)

f. Hood and Latch and Rear Enclosure (cont).

STEP	LOCATION	ITEM	ACTION	REMARKS
REMOVAL (cont)				
5	Hood, top	a. Three screws (29), lock-nuts (30), and washers (31)	Remove	
		b. Two capscrews (32) and washers (33)	Remove	
		c. Capscrew (34) and nut (35)	Remove	Support hood support (37)
		d. Cab mount (36)	Remove	
		e. Hood support (37)	Remove	
CLEANING				
6		a. Latches (11)	Clean	Use clean cloth moistened with detergent. Dry using clean cloth

WARNING

Dry cleaning solvent (P-D-680), used to clean parts is toxic and flammable. Wear protective goggles and gloves and use only in a well ventilated area. Avoid contact with skin, eyes, and clothes and don't breathe vapors. Do not use near open flame or excessive heat and don't smoke when using it. Failure to do so could cause serious injury. If you become dizzy while using cleaning solvent, get fresh air and medical attention immediately. If contact with skin or clothes is made, flush with large amounts of water. If contact with eyes is made, wash eyes with water and seek medical aid immediately.

Compressed air must not exceed 30 psi. Wear safety glasses when drying parts with compressed air. Failure to do so could cause serious injury to eyes and possible blindness. If you hurt your eyes or if a foreign object is blown into your eyes, seek medical attention immediately.

2-65. BODY AND CAB MAINTENANCE (CONT)

f. Hood and Latch and Rear Enclosure (cont).

STEP	LOCATION	ITEM	ACTION	REMARKS
CLEANING (cont)				
6 (cont)		b. All other parts	Clean	Use cleaning solvent P-D-680; dry using compressed air. If necessary, use wire brush to remove rust
INSPECTION				
7		a. Hood (4)	Inspect for: cracks dents bent condition	Replace if defective
		b. Latches (11)	Inspect for: cracks breaks damage	Replace if defective
		c. Hinge (21), angle bracket (22), and hood support (37)	Inspect for: cracks damaged holes bent condition	Replace if defective
		d. Rear engine enclosure panel (28)	Inspect for: cracks dents	Replace if defective
		e. All other parts	Inspect for: thread damage deformation cracks breaks wear	Replace if defective
INSTALLATION/REPLACEMENT				
8	Hood, top	a. Hood support (37) and cab mount (36)	Position	
		b. Capscrew (35) and nut (34)	Install and tighten	
		c. Two capscrews (32) and washers (33)	Install and tighten	

2-65. BODY AND CAB MAINTENANCE (CONT)

f. Hood and Latch and Rear Enclosure (cont).

STEP	LOCATION	ITEM	ACTION	REMARKS
INSTALLATION/REPLACEMENT (cont)				
8 (cont)		d. Three screws (29), washers (31), and locknuts (30)	Install and tighten	
9	Hood, rear	a. Rear engine enclosure panel (28)	Position	
		b. Three capscrews (26) and washers (27)	Install and tighten	
		c. Five screws (23), washers (25), and locknuts (24)	Install and tighten	

NOTE

When performing step 10 below, be sure that hinge (21) leaf with oblong holes parallel to leaf is installed on hood enclosure.

10	Hood, top	a. Angle bracket (22) and hinge (21)	Position	
		b. Screw (18), washer (20), and locknut (19)	Install and tighten	Through top of hood, hinge, angle bracket, and hood support
		c. Seven screws (15), washers (17), and locknuts (16)	Install and tighten	
11	Cab deck weldment	a. Two pivot brackets (14)	Position	
		b. Four screws (12) and locknuts (13)	Install and tighten	
		c. Two latches (11)	Position	Between ears of pivot brackets (14)
		d. Two shafts (10)	Install	Through pivot brackets (14) ears and latches (11)

2-65. BODY AND CAB MAINTENANCE (CONT)

f. Hood and Latch and Rear Enclosure (cont).

STEP	LOCATION	ITEM	ACTION	REMARKS
INSTALLATION/REPLACEMENT (cont)				
11 (cont)		e. Two washers (9) f. Two cotter pins (8)	Install Install	On shafts (10) On shafts (10)
12	Hood (4)	a. Two latch brackets (7) b. Four screws (5) and locknuts (6)	Position Install and tighten	
13	Hood, top	a. Hinge (21) leaf b. Hood (4) c. Seven capscrews (1), washers (3), and locknuts (2)	Position Position Install and tighten	Open hinge leaf Align holes in hinge (21) leaf and holes in hood (4)
14	Rear engine enclosure panel (28)	a. 12-volt and 24-volt receptacles b. Windshield washer pump and reservoir c. Trailer light- ing cable	Install Install Connect	Para 2-30 Para 2-69c Para 2-31f
ADJUSTMENT				
15	Hood, top	a. Hood (4) b. Hinge (21) c. Hood (4)	Close hood (4) and check if hood hits side of hood enclosure. If hood hits side of enclosure, loosen screws (15 and 18) and move hood (4) until it is centered between sides of hood enclosure. Tighten screws (15 and 18) Close hood (4) and check if hood hits cab deck weldment. If hood hits cab deck weldment, loosen screws (1) and raise hood. Tighten screws (1) Close hood and secure with latches (11)	

2-65. BODY AND CAB, MAINTENANCE (CONT)

g. Radiator Access Panel.

This task covers: a. Removal c. Inspection
 b. Cleaning d. Installation/Replacement

INITIAL SETUP

Tools

No. 1 Common Organizational Maintenance

Tool Kit

- Socket wrench set, 3/8 inch drive
- Open end wrench set
- Scratch wire brush
- Safety glasses
- Flat tip screwdriver

Air compressor

Materials/Parts

- Cleaning solvent Item 1, Appendix C
- Clean cloths Item 2, Appendix C

Personnel Required

Wheel Vehicle Mechanic MOS 63B

Equipment Condition

Paragraph Condition Description

Vehicle parked on level surface, engine off, and parking brake applied.

KEY

1. Screw
2. Nut
3. Washer
4. Latch
5. Washers (3)
6. Capscrews (2)
7. Locknuts (2)
8. Washers (2)
9. Radiator access plate
10. Self-adhesive rubber strips (4)

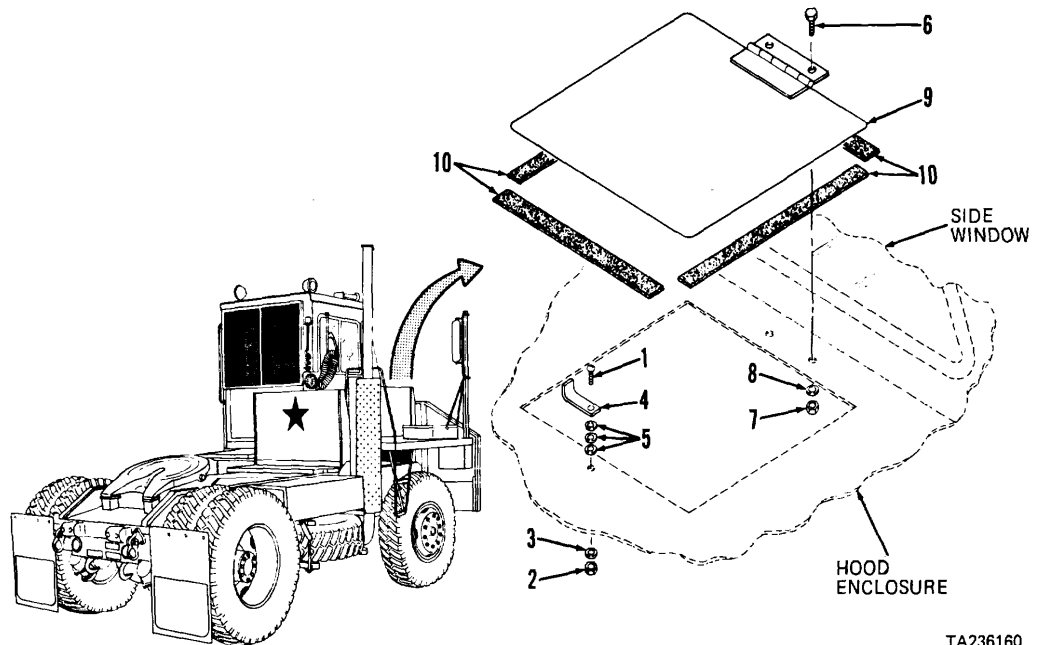

TA236160

2-65. BODY AND CAB MAINTENANCE (CONT)

g. Radiator Access Panel (cont).

STEP	LOCATION	ITEM	ACTION	REMARKS
REMOVAL				
1	Hood enclosure, top	a. Latch (4)	Position	Away from radiator access plate (9)
		b. Radiator access plate (9)	Lift up	Allow to rest on cab wall
		c. Screw (1), nut (2), and washer (3)	Remove	
		d. Latch (4)	Remove	
		e. Three washers (5)	Remove	
		f. Two capscrews (6), lock-nuts (7), and washers (8)	Remove	
		g. Radiator access plate (9)	Remove	

NOTE

Don't remove self-adhesive rubber strips (10) unless inspection indicates replacement is necessary.

CLEANING

WARNING

Dry cleaning solvent (P-D-680), used to clean parts is toxic and flammable. Wear protective goggles and gloves and use only in a well ventilated area. Avoid contact with skin, eyes, and clothes and don't breathe vapors. Do not use near open flame or excessive heat and don't smoke when using it. Failure to do so could cause serious injury. If you become dizzy while using cleaning solvent, get fresh air and medical attention immediately. If contact with skin or clothes is made, flush with large amounts of water. If contact with eyes is made, wash eyes with water and seek medical aid immediately.

2-45. BODY AND CAB MAINTENANCE (CONT)

g. Radiator Access Panel (cont).

STEP	LOCATION	ITEM	ACTION	REMARKS
------	----------	------	--------	---------

CLEANING (cont)

WARNING

Compressed air must not exceed 30 psi. Wear safety glasses when drying parts with compressed air. Failure to do so could cause serious injury to eyes and possible blindness. If you hurt your eyes or if a foreign object is blown into your eyes, seek medical attention immediately.

2		All parts	Clean	Use cleaning solvent P-D-680; if necessary use stiff wire brush to remove rust. Dry using compressed air
---	--	-----------	-------	--

INSPECTION

3		a. Latch (4)	Inspect for: cracks breaks bent condition	Replace if defective
		b. Radiator access plate (9)	Inspect for: cracks dents hinge damaged	Replace if defective

WARNING

Dry cleaning solvent (P-D-680), used to clean parts is toxic and flammable. Wear protective goggles and gloves and use only in a well ventilated area. Avoid contact with skin, eyes, and clothes and don't breathe vapors. Do not use near open flame or excessive heat and don't smoke when using it. Failure to do so could cause serious injury. If you become dizzy while using cleaning solvent, get fresh air and medical attention immediately. If contact with skin or clothes is made, flush with large amounts of water. If contact with eyes is made, wash eyes with water and seek medical aid immediately.

2-65. BODY AND CAB MAINTENANCE (CONT)

g. Radiator Access Panel (cont).

STEP	LOCATION	ITEM	ACTION	REMARKS
------	----------	------	--------	---------

INSPECTION (cont)

3
(cont)

WARNING

Compressed air must not exceed 30 psi. Wear safety glasses when drying parts with compressed air. Failure to do so could cause serious injury to eyes and possible blindness. If you hurt your eyes or if a foreign object is blown into your eyes, seek medical attention immediately.

		c. Self-adhesive rubber strips (10)	Inspect for: cracks gouges breaks	Replace if defective. Use sharp edged object and scrape strip from hood enclosure. Clean area using cleaning solvent P-D-680 and dry using compressed air
		d. All other parts threads deformation	Inspect for: damaged	Replace if defective

INSTALLATION/REPLACEMENT

4	Hood enclosure, top	a. New self-adhesive rubber strips (10)	Install if removed	Peel paper backing off a strip cut 8 inches long. Place alongside edge of radiator access hole and press down
		b. Radiator access Position plate (9)		
		c. Two capscrews (6), washers (8), and locknuts (7)	Install	
		d. Latch (4) and three washers (5)	Install on screw (1)	
		e. Screw (1), washer (3), and nut (2)	Install	
		f. Radiator access plate (9)	Close	
		g. Latch (4)	Position	Over radiator access plate (9)

2-65. BODY AND CAB MAINTENANCE (CONT)

h. Cab Grille.

This task covers: a. Removal c. Inspection
 b. Cleaning d. Installation

INITIAL SETUP

Tools

No. 1 Common Organizational Maintenance

Tool Kit

Socket wrench set, 3/8 inch drive

Open end wrench set

Safety glasses

Welding shop equipment

Air compressor

Materials/Parts

Cleaning solvent

Item 1, Appendix C

Clean cloths

Item 2, Appendix C

Personnel Required

Wheel Vehicle Mechanic MOS 63B

Equipment Condition

Paragraph Condition Description

Vehicle parked on level surface, engine off, and parking brake applied. Cab tilted 45 degrees.

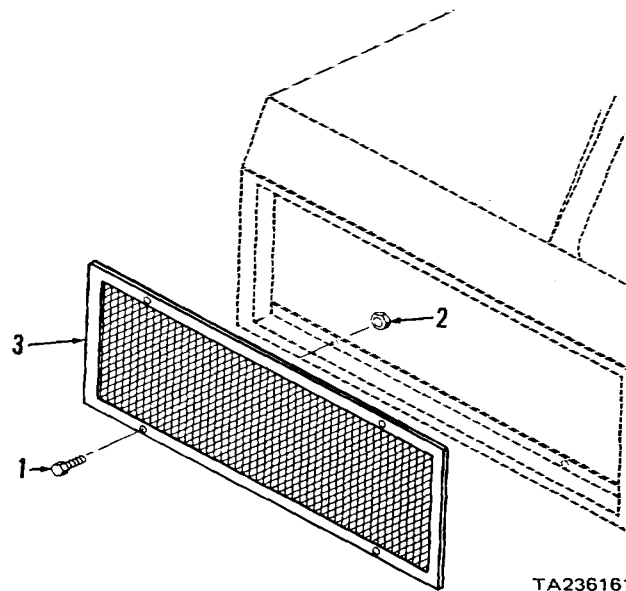
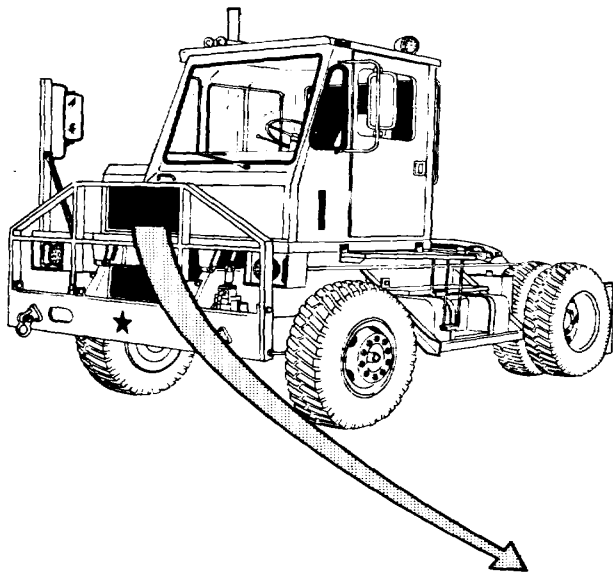

TA236161

KEY

- 1. Capscrews (4)
- 2. Locknuts (4)
- 3. Cab grille

2-65. BODY AND CAB MAINTENANCE (CONT)

h. Cab Grille (cont).

STEP	LOCATION	ITEM	ACTION	REMARKS
REMOVAL				
1	Front of vehicle, behind grille guard	a. Four capscrews (1) and lock-nuts (2)	Remove	Support cab grille (3)
		b. Cab grille (3)	Remove	

CLEANING

WARNING

Dry cleaning solvent (P-D-680), used to clean parts is toxic and flammable. Wear protective goggles and gloves and use only in a well ventilated area. Avoid contact with skin, eyes, and clothes and don't breathe vapors. Do not use near open flame or excessive heat and don't smoke when using it. Failure to do so could cause serious injury. If you become dizzy while using cleaning solvent, get fresh air and medical attention immediately. If contact with skin or clothes is made, flush with large amounts of water. If contact with eyes is made, wash eyes with water and seek medical aid immediately. Compressed air must not exceed 30 psi. Wear safety glasses when drying parts with compressed air. Failure to do so could cause serious injury to eyes and possible blindness. If you hurt your eyes or if a foreign object is blown into your eyes, seek medical attention immediately.

2		All parts	Clean	Use cleaning solvent P-D-680; dry using compressed air
---	--	-----------	-------	--

INSPECTION

3		a. Cab grille (3)	Inspect for: broken welds cracks dents	Repair broken welds by welding; replace if other defects are observed
---	--	-------------------	---	---

2-65. BODY AND CAB MAINTENANCE (CONT)

h. Cab Grille (cont).

STEP	LOCATION	ITEM	ACTION	REMARKS
INSPECTION (cont)				
3 (cont)		b. All other parts	Inspect for: damaged threads deformation	Replace if defective
INSTALLATION				
4	Front of vehicle, behind grille guard	a. Cab grille (3) b. Four capscrews (1) and locknuts (2)	Position Install and tighten	

2-734

2-65. BODY AND CAB MAINTENANCE (CONT)

i. Door and Arm Rest.

This task covers: a. Removal c. Inspection
 b. Cleaning d. Installation/Replacement

INITIAL SETUP

Tools

No. 1 Common Organizational Maintenance
 Tool Kit

- Flat tip screwdriver
- Socket wrench set, 3/8 inch drive
- Open end wrench set
- Scratch wire brush
- Safety glasses

Pliers
 Air compressor

Detergent Item 27, Appendix C
 Thread sealant Item 29, Appendix C
 Weatherstrip FSCM 90915 PN 90004040

Personnel Required

Two Wheel Vehicle Mechanics MOS 63B

Equipment Condition

Paragraph Condition Description

Materials/Parts

Cleaning solvent Item 1, Appendix C
 Clean cloths Item 2, Appendix C
 Adhesive Item 11, Appendix C

Vehicle parked on level surface, engine off, and parking brake applied.

STEP	LOCATION	ITEM	ACTION	REMARKS
------	----------	------	--------	---------

REMOVAL

1	Cab interior, left side, door (13)	a. Two capscrews (1)	Remove
		b. Handle (2)	Remove
		c. Two screws (3) and washers (4)	Remove
		d. Arm rest (5)	Remove
2	Door, top and bottom	a. Four cotter pins (6)	Remove
		b. Four clevis pins (7)	Remove
		c. Two door restraints (8)	Remove
		d. Four capscrews (9)	Remove
		e. Two brackets (10)	Remove

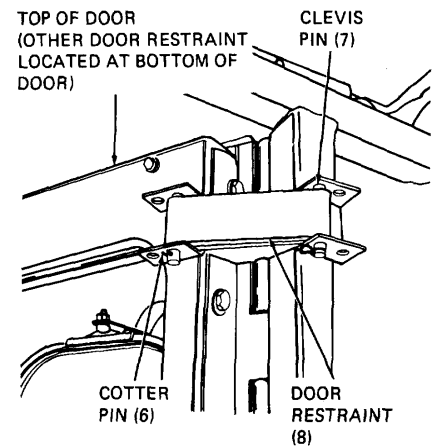

TA236166

2-65. BODY AND CAB MAINTENANCE (CONT)

i. Door and Arm Rest (cont).

KEY

- 1. Capscrews (2)
- 2. Handle
- 3. Screws (2)
- 4. Washers (2)
- 5. Arm rest
- 6. Cotter pins (4)
- 7. Clevis pins (4)
- 8. Door restraints (2)
- 9. Capscrews (4)
- 10. Brackets (2)
- 11. Capscrews (13)
- 12. Washers (13)

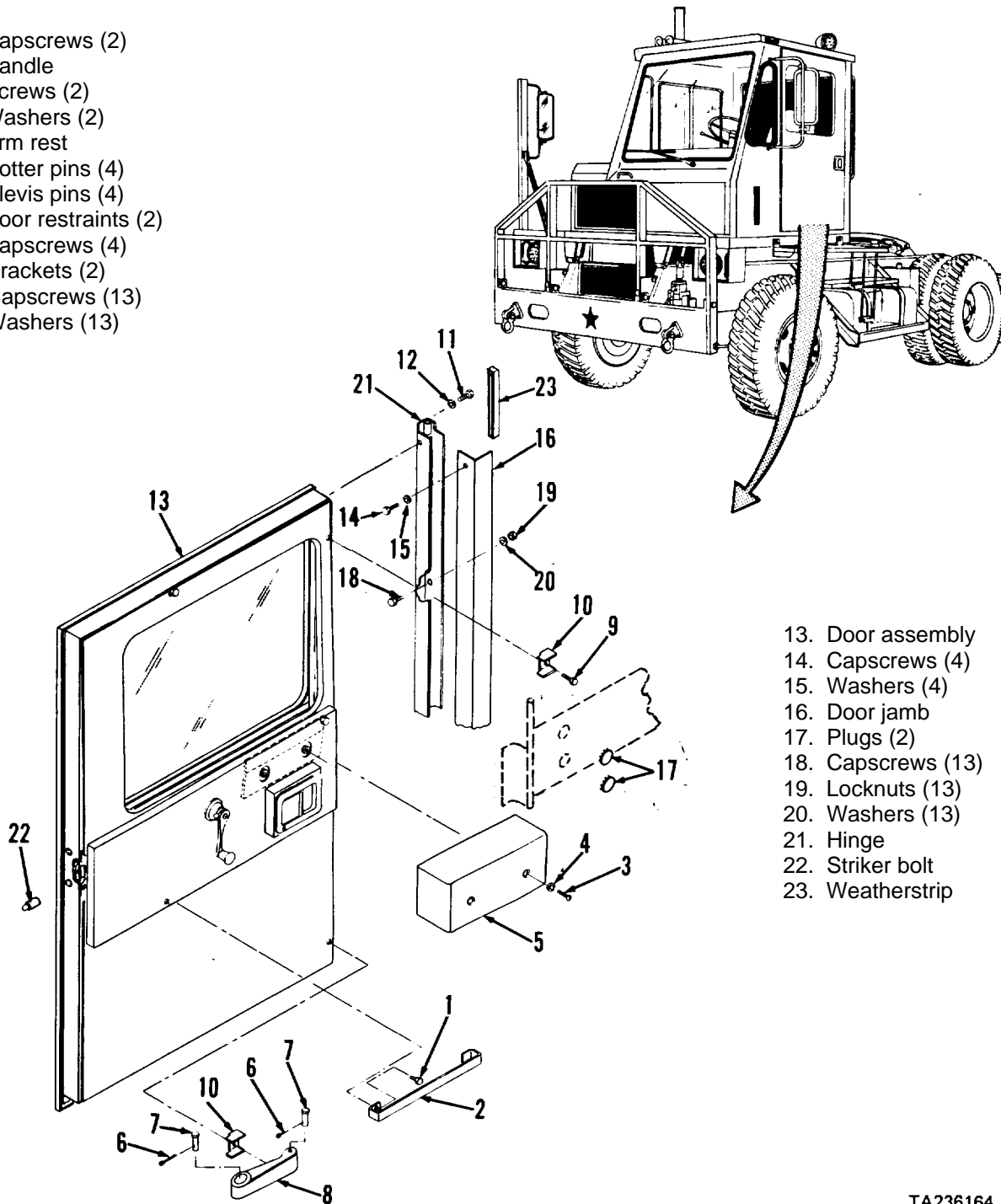

- 13. Door assembly
- 14. Capscrews (4)
- 15. Washers (4)
- 16. Door jamb
- 17. Plugs (2)
- 18. Capscrews (13)
- 19. Locknuts (13)
- 20. Washers (13)
- 21. Hinge
- 22. Striker bolt
- 23. Weatherstrip

TA236164

2-65. BODY AND CAB MAINTENANCE (CONT)

i. Door and Arm Rest (cont).

STEP	LOCATION	ITEM	ACTION	REMARKS
REMOVAL (cont)				
3	Cab interior, left side	a. Door (13)	Open	Swing completely open to gain access to capscrews (11) From hinge (21)
		b. Weatherstrip (23)	Remove	
<u>CAUTION</u>				
Support door (13) when performing the following step. Failure to do so could cause door to fall breaking window glass and damaging door.				
4	Cab interior, door jamb (16)	c. 13 capscrews (11) and washers (12)	Remove	Support door (13)
		d. Door (13)	Remove	
		a. Four capscrews (14) and washers (15)	Remove	Support door jamb (16)
		b. Door jamb (16)	Remove	
		c. Plugs (17)	Remove	Pop out
5	Doorway, opposite hinge (21)	d. 13 capscrews (18), lock-nuts (19), and washers (20)	Remove	Support hinge (21)
		e. Hinge (21)	Remove	
		Striker bolt (22)	Remove	Only if necessary
CLEANING				
6		a. Arm rest (5) and inside of door (13)	Clean	Use clean cloth moistened with detergent and rinse with clear, clean water. Dry using clean cloth

2-65. BODY AND CAB MAINTENANCE (CONT)

i. Door and Arm Rest (cont).

STEP	LOCATION	ITEM	ACTION	REMARKS
------	----------	------	--------	---------

CLEANING (cont)

(cont)

6 WARNING

Dry cleaning solvent (P-D-680), used to clean parts is toxic and flammable. Wear protective goggles and gloves and use only in a well ventilated area. Avoid contact with skin, eyes, and clothes and don't breathe vapors. Do not use near open flame or excessive heat and don't smoke when using it. Failure to do so could cause serious injury. If you become dizzy while using cleaning solvent, get fresh air and medical attention immediately. If contact with skin or clothes is made, flush with large amounts of water. If contact with eyes is made, wash eyes with water and seek medical aid immediately.

Compressed air must not exceed 30 psi. Wear safety glasses when drying parts with compressed air. Failure to do so could cause serious injury to eyes and possible blindness. If you hurt your eyes or if a foreign object is blown into your eyes, seek medical attention immediately.

b. All other parts

Clean

Use cleaning solvent P-D-680; if necessary, use a stiff wire brush to remove any rust. Dry using compressed air

INSPECTION

7

a. Door restraints (8), handle (2), door jamb (16), and hinge (20)

Inspect for:
cracks
breaks
bent
condition
dents

Replace if defects are observed

b. Arm rest (5)

Inspect for:
tears
damage

Replace if defects are observed

c. Door (13)

Inspect for:
dents
cracked or

Replace if defects are observed (notify direct support maintenance).

Check

broken
window

lock and window regulator for proper operation

2-65. BODY AND CAB MAINTENANCE (CONT)

i. Door and Arm Rest (cont).

STEP	LOCATION	ITEM	ACTION	REMARKS
INSPECTION (cont)				
7 (cont)		d. Striker bolt (22)	Inspect for: cracks wear	Replace if defects are observed
		e. Remaining parts	Inspect for: thread damage deformation	Replace if defects are observed
INSTALLATION/ REPLACEMENT				
8	Doorway, opposite hinge (21)	Striker bolt (22)	a. Apply loctite b. Install	To threads
9	Cab interior, door hinge (21) side	a. Hinge (21)	Position	Secures hinge (21)
		b. 13 capscrews (18), washers (20), and locknuts (19)	Install	
		c. Door jamb (16)	Position	Secures door jamb (16)
		d. Four capscrews (14) and washers (15)	Install	
e. Two plugs (17)	Install	In cab interior post		
<u>CAUTION</u>				
Support door (13) when performing the following step. Failure to do so could cause door to fall breaking window glass and damaging door.				
10	Cab exterior, door hinge (21) side	a. Door (13)	Position	Align holes in hinge and door Secures door to hinge (21)
		b. 13 capscrews (11) and washers (12)	Install	
		c. Weatherstrip (23)	Install	On hinge (21) using adhesive
		d. Door (13)	Close	
11	Cab interior, top and bottom	a. Two brackets (10)	Position	At top and bottom of door
		b. Four capscrews (9)	Install	Secures brackets (10) to door

2-65. BODY AND CAB MAINTENANCE (CONT)

i. Door and Arm Rest (cont).

STEP	LOCATION	ITEM	ACTION	REMARKS
INSTALLATION/REPLACEMENT (cont)				
11 (cont)		c. Two door restraints (8)	Position	On brackets (10) attached to door and brackets attached to cab wall
		d. Four clevis pins (7)	Install	
		e. Four cotter pins (6)	Install and spread	Secures clevis pins (7)
12	Cab interior, door (13)	a. Arm rest (5)	Position	See that door opens and closes properly. If adjustment is required, loosen capscrews (11), then shift door and tighten capscrews. Adjust striker bolt (22) if necessary
		b. Two screws (3) and washers (4)	Install	
		c. Handle (2)	Position	
		d. Two capscrews (1)	Install	
		e. Door (13)	Check	

2-65. BODY AND CAB MAINTENANCE (CONT)

j. Rear Window Guard.

This task covers: a. Removal c. Inspection
 b. Cleaning d. Installation/Replacement

INITIAL SETUP

Tools

No. 1 Common Organizational Maintenance

Tool Kit

Socket wrench set, 3/8 inch drive

Open end wrench set

Safety glasses

Pliers

Welding shop equipment

Screw threading set

Air compressor

Materials/Parts

Cleaning solvent

Item 1, Appendix C

Clean cloths

Item 2, Appendix C

Personnel Required

Wheel Vehicle Mechanic MOS 63B

Equipment Condition

Paragraph Condition Description

2-31f Vehicle parked on level surface, engine off, and parking brake applied.
 Trailer lighting cable and plug holder removed.

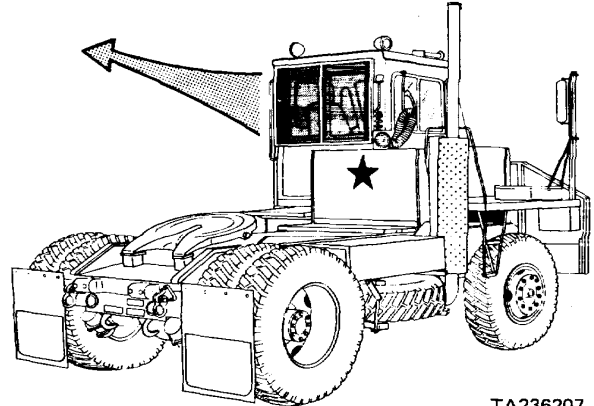
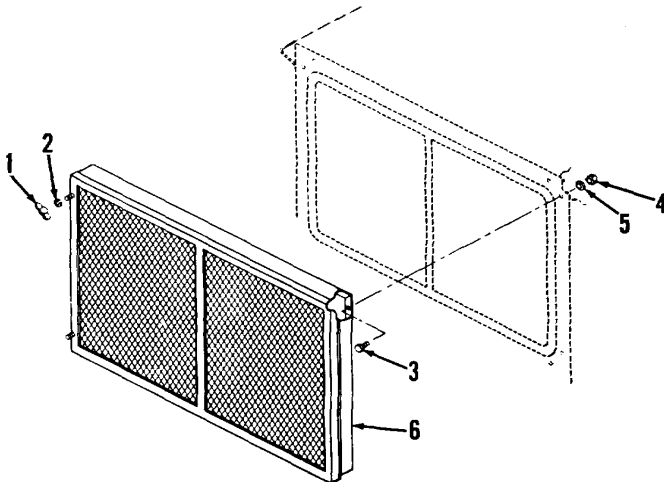

TA236207

KEY

- 1. Wing nuts (2)
- 2. Lock washers (2)
- 3. Capscrews (7)
- 4. Locknuts (7)
- 5. Washers (7)
- 6. Rear window guard

2-65. BODY AND CAB MAINTENANCE (CONT)

j. Rear Window Guard (cont).

STEP	LOCATION	ITEM	ACTION	REMARKS
REMOVAL				
1	Cab rear	a. Two wing nuts (1) and lock washers (2)	Remove	Swing window guard screen open to gain access to capscrews (3)
		b. Seven capscrews (3), locknuts (4), and washers (5)	Remove	Support rear window guard (6)
		c. Rear window guard (6)	Remove	

CLEANING

WARNING

Dry cleaning solvent (P-D-680), used to clean parts is toxic and flammable. Wear protective goggles and gloves and use only in a well ventilated area. Avoid contact with skin, eyes, and clothes and don't breathe vapors. Do not use near open flame or excessive heat and don't smoke when using it. Failure to do so could cause serious injury. If you become dizzy while using cleaning solvent, get fresh air and medical attention immediately. If contact with skin or clothes is made, flush with large amounts of water. If contact with eyes is made, wash eyes with water and seek medical aid immediately.

Compressed air must not exceed 30 psi. Wear safety glasses when drying parts with compressed air. Failure to do so could cause serious injury to eyes and possible blindness. If you hurt your eyes or if a foreign object is blown into your eyes, seek medical attention immediately.

2	All parts	Clean		Use cleaning solvent P-D-680; dry using compressed air
---	-----------	-------	--	--

2-65. BODY AND CAB MAINTENANCE (CONT)

j. Rear Window Guard (cont).

STEP	LOCATION	ITEM	ACTION	REMARKS
INSPECTION				
3		a. Rear window guard (6)	Inspect for: broken welds cracks bent condition damaged or cracked hinge stud damaged	Repair broken welds by welding; if studs are damaged, chase using 5/16-18 die. Replace if other defects are observed
		b. All other parts	Inspect for: thread damage distortion deformation	Replace if defective
INSTALLATION/REPLACEMENT				
4	Cab rear	a. Rear window guard (6)	Position	Align rear window guard holes with mounting holes in cab wall
		b. Seven capscrews (3), washers (5), and locknuts (4)	Install	
		c. Rear window guard (6) screen	Close	
		d. Two wing nuts (1) and lock washers (2)	Install	
		e. Plug holder and trailer lighting cable	Install	Para 2-31f

2-65. BODY AND CAB MAINTENANCE (CONT)

k. Cab Pivot Pins and Bushings.

- This task covers:
- a. Removal
 - b. Cleaning
 - c. Inspection
 - d. Installation/Replacement

INITIAL SETUP

Tools

No. 1 Common Organizational Maintenance Tool Kit

- Socket wrench set, 1/2 inch drive
- Adjustable open end wrench
- Safety glasses

Chain hoist

Wood blocks, 6 by 6 by 6 inches

Sleeve, 1-15/16 inches outer diameter

Air compressor

Personnel Required

Two Wheel Vehicle Mechanics MOS 63B

Equipment Condition

Paragraph Condition Description

Vehicle parked on level surface, engine off, and parking brake applied.
Grille guard lowered.

Materials/Parts

- Cleaning solvent Item 1, Appendix C
- Clean cloths Item 2, Appendix C
- Rubber mounts FSCM 76005 PN H9004-1

KEY

1. Lubrication fittings (2)
2. Locknuts (2)
3. Washers (2)
4. Pivot pins (2)
5. Rubber mounts (2)

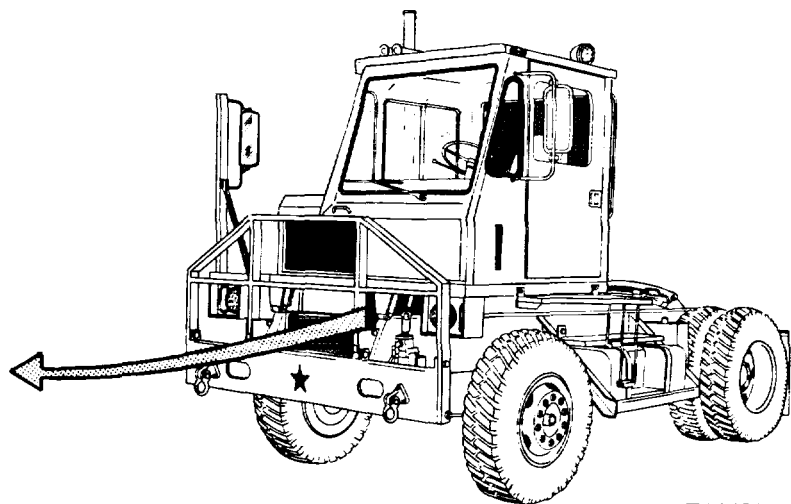
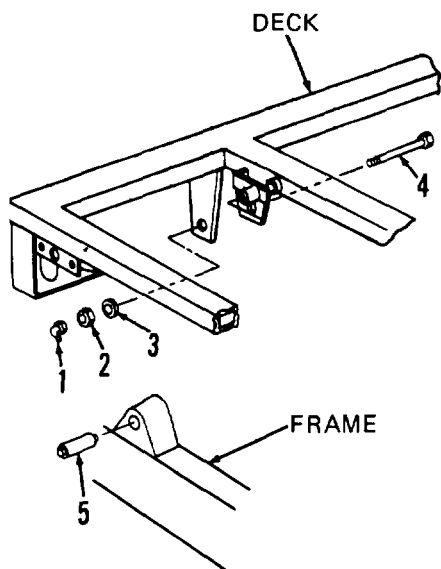

TA236208

2-65. BODY AND CAB MAINTENANCE (CONT)

k. Cab Pivot Pins and Bushings (cont).

STEP	LOCATION	ITEM	ACTION	REMARKS
REMOVAL				
1	Right side of vehicle	a. Cab hydraulic pump	Raise cab and deck	Approximately one foot
		b. Wood blocks	Position	Under cab deck on frame rail (both sides of frame) next to hydraulic locks
		c. Cab hydraulic pump	Lower cab onto wood blocks	
2	Front of vehicle, under cab deck	a. Chain hoist	Attach to deck	Near deck pivot points. Take up chain slack
		b. Two lubrication fittings (1)	Remove	
		c. Two locknuts (2) and washers (3)	Remove	

WARNING

Be sure chain hoist is securely fastened to cab deck before performing the following step. Failure to do so could cause serious injury or death due to cab deck falling on you. If you are injured by falling equipment, obtain medical aid immediately.

d. Two pivot pins (4)	Remove if necessary	Use brass hammer and drift
e. Cab and deck	Raise	Approximately three inches, just enough to enable removal of two rubber mounts (5)
f. Wood blocks	Install	Under cab deck to support deck

WARNING

Be sure cab and deck are securely blocked before performing the following step. Failure to do so could cause death or serious injury due to cab and deck falling on you. If you are injured by falling equipment, obtain medical aid immediately.

g. Two rubber mounts (5)	Remove and discard	Use 1-15/16 inches diameter sleeve or rod; remove from inside outward
--------------------------	--------------------	---

2-65. BODY AND CAB MAINTENANCE (CONT)

k. Cab Pivot Pins and Bushings (cont).

STEP	LOCATION	ITEM	ACTION	REMARKS
------	----------	------	--------	---------

CLEANING

WARNING

Dry cleaning solvent (P-D-680), used to clean parts is toxic and flammable. Wear protective goggles and gloves and use only in a well ventilated area. Avoid contact with skin, eyes, and clothes and don't breathe vapors. Do not use near open flame or excessive heat and don't smoke when using it. Failure to do so could cause serious injury. If you become dizzy while using cleaning solvent, get fresh air and medical attention immediately. If contact with skin or clothes is made, flush with large amounts of water. If contact with eyes is made, wash eyes with water and seek medical aid immediately.

Compressed air must not exceed 30 psi. Wear safety glasses when drying parts with compressed air. Failure to do so could cause serious injury to eyes and possible blindness. If you hurt your eyes or if a foreign object is blown into your eyes, seek medical attention immediately.

3	All parts		Clean	Use cleaning solvent P-D-680; dry using compressed air
---	-----------	--	-------	--

INSPECTION

4	All parts		Inspect for: thread damage distortion deformation	Replace if defective
---	-----------	--	---	----------------------

INSTALLATION/REPLACEMENT

WARNING

Be sure cab and deck are securely blocked before performing the following step. Failure to do so could cause death or serious injury due to cab and deck falling on you. If you are injured by falling equipment, obtain medical aid immediately.

2-65. BODY AND CAB MAINTENANCE (CONT)

k. Cab Pivot Pins and Bushings (cont).

STEP	LOCATION	ITEM	ACTION	REMARKS
INSTALLATION/REPLACEMENT (cont)				
5	Front of vehicle, under cab deck	a. Two rubber mounts (5)	Install	Compress and install from outside inward. Use 1-15/16 inches sleeve or rod bearing on metal shoulder to complete installation. Install until shoulder is against lug
		b. Cab and deck	Raise	Just enough to remove wood blocks
		c. Wood blocks	Remove	
		d. Cab and deck	Lower	Just enough to enable installation of pivot pins (4)
		e. Two pivot pins (4)	Install	In deck ears through rubber mounts (5)
		f. Two washers (3) and locknuts (2)	Install and tighten	
		g. Two lubrication fittings (1)	Install	
		h. Chain hoist	Lower and disconnect	Disconnect from deck
6	Right side of vehicle	a. Cab hydraulic pump	Raise cab and deck	Just enough to remove wood blocks
		b. Wood blocks	Remove	
		c. Cab hydraulic pump	Lower cab	

2-65. BODY AND CAB MAINTENANCE (CONT)

1. Seat Belt and Seat.

This task covers: a. Removal c. Inspection and Repair
 b. Cleaning d. Installation/Replacement

INITIAL SETUP

Tools

No. 1 Common Organizational Maintenance
 Tool Kit
 Socket wrench set, 1/2 inch drive
 Open end wrench set

References

TM 9-2320-285-10
 (M878A1 Operator's Manual)

Equipment Condition

Paragraph Condition Description

Materials/Parts

Cleaning solvent Item 1, Appendix C
 Clean cloths Item 2, Appendix C
 Detergent Item 27, Appendix C
 Clean warm water
 Needle and thread

Vehicle parked on level surface, engine off, and parking brake applied.

Personnel Required

Two Wheel Vehicle Mechanics MOS 63B

KEY

- | | |
|---------------------------|-------------------|
| 1. Capscrews (2) | 8. Tethers (2) |
| 2. Lock washers (2) | 9. Locknuts (4) |
| 3. Seat belt | 10. Washers (4) |
| 4. Nuts (2) | 11. Capscrews (4) |
| 5. Lock washers (2) | 12. Washers (4) |
| 6. Reinforcing plates (2) | 13. Seat assembly |
| 7. Capscrews (2) | |

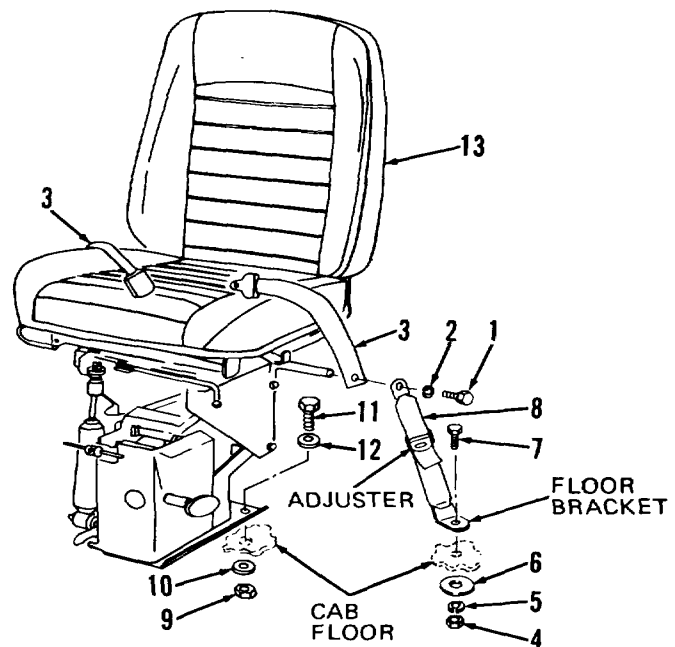
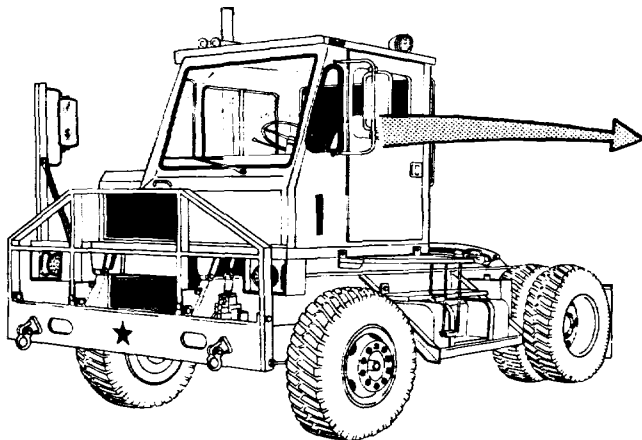

TA236167

2-65. BODY AND CAB MAINTENANCE (CONT)

1. Seat Belt and Seat (cont).

STEP	LOCATION	ITEM	ACTION	REMARKS
REMOVAL				
1	Cab interior, operator's seat, left and right sides	a. Two capscrews (1) and lock washers (2)	Remove	
		b. Seat belt (3)	Remove	
2	Cab floor, near seat, left and right sides	a. Two nuts (4), lock washers (5), reinforcing plates (6), and capscrews (7)	Remove	
		b. Two tethers (8)	Remove	
		c. Four locknuts (9), washers (10), capscrews (11), and washers (12)	Remove	
		d. Seat assembly (13)	Remove	From cab interior
CLEANING				
3		a. Seat assembly (13)	Clean	Use clean cloth moistened with clean water and detergent; dry using clean cloths

WARNING

Don't bleach or dye tethers (8) or seat belt (3). To do so may reduce their strength resulting in seat belt or tether breaking under stress, in turn, causing serious injury or death in the event of an accident involving stress on these parts.

b. Tether (8) and seat belt (3)	Clean	Hand wash with warm water and detergent; rinse thoroughly and dry in shade
---------------------------------	-------	--

2-65. BODY AND CAB MAINTENANCE (CONT)

1. Seat Belt and Seat (cont).

STEP	LOCATION	ITEM	ACTION	REMARKS
------	----------	------	--------	---------

CLEANING (cont)

WARNING

Dry cleaning solvent (P-D-680), used to clean parts is toxic and flammable. Wear protective goggles and gloves and use only in a well ventilated area. Avoid contact with skin, eyes, and clothes and don't breathe vapors. Do not use near open flame or excessive heat and don't smoke when using it. Failure to do so could cause serious injury. If you become dizzy while using cleaning solvent, get fresh air and medical attention immediately. If contact with skin or clothes is made, flush with large amounts of water. If contact with eyes is made, wash eyes with water and seek medical aid immediately.

		c. All other parts	Clean	Use cleaning solvent P-D-680; dry using clean cloths
--	--	--------------------	-------	--

INSPECTION AND REPAIR

4		a. Seat belt (3)	Inspect for: torn or frayed webbing inoperative retractor or buckle damaged latch or mounting holes	Replace if defects are observed
		b. Tethers (8)	Inspect for: torn or frayed webbing damaged brackets or mounting holes damaged adjusters	Replace if defects are observed

2-65. BODY AND CAB MAINTENANCE (CONT)

1. Seat Belt and Seat (cont).

STEP	LOCATION	ITEM	ACTION	REMARKS
INSPECTION AND REPAIR (cont)				
4 (cont)		c. Seat assembly (13)	Inspect for: rips worn areas deterioration at seat and back proper operation	Repair small tears or rips using needle and thread; replace if uneconomical to repair (notify direct support maintenance). Refer to TM 9-2320-285-10 for seat adjustments to check for proper operation
		d. All other parts	Inspect for: damaged threads distortion deformation	Replace if defects are observed
INSTALLATION/ REPLACEMENT				
5	Cab interior	Seat assembly (13)	Position	Align mounting holes in seat assembly (13) with mounting holes in cab floor
6	Cab floor, near seat, left and	a. Four washers (12), cap- screws (11), right sides and locknuts (9)	Install to cab floor washers (10),	Secures seat assembly (13)
		b. Tether (8) floor bracket	Position holes	On cab floor; align mounting
		c. Two capscrews (7), rein- forcing plates (6), lock washers (5), and nuts (4)	Install	Do not tighten

NOTE

Adjust tethers (8) adjusters to obtain more slack in tethers (8) as necessary when performing the following step.

2-65. BODY AND CAB MAINTENANCE (CONT)

1. Seat Belt and Seat (cont).

STEP	LOCATION	ITEM	ACTION	REMARKS
INSTALLATION/REPLACEMENT (cont)				
7	Seat assembly (13), left and right sides	a. Seat belt (3) and tethers (8)	Position	On seat assembly (13) threaded rod; align mounting holes
		b. Two lock washers (2) and capscrews (1)	Install	
		c. Seat assembly (13)	Slide	Refer to TM 9-2320-285-10 and move seat assembly (13) to most forward position
		d. Tethers (8) adjuster	Adjust	Take up most but not all of slack in tethers with seat up fully
		e. Two nuts (4) and capscrews (7)	Tighten	
		f. Seat assembly (13)	Adjust	Refer to TM 9-2320-285-10 and adjust seat to operator

2-752

2-65. BODY AND CAB MAINTENANCE (CONT)

m. Paper Compartment.

This task covers: a. Removal c. Inspection
 b. Cleaning d. Installation

INITIAL SETUP

Tools

No. 1 Common Organizational Maintenance

Tool Kit

- Socket wrench set, 3/8 inch drive
- Open end wrench set
- Safety glasses
- Scratch wire brush
- Hand hammer

Wood block, 2 by 4 by 6 inches
 Air compressor

Personnel Required

Wheel Vehicle Mechanic MOS 63B

Equipment Condition

Paragraph Condition Description

Vehicle parked on level surface, engine off, and parking brake applied.

Materials/Parts

Cleaning solvent Item 1, Appendix C
 Clean cloths Item 2, Appendix C

KEY

1. Locknuts (4)
2. Washers (4)
3. Capscrews (4)
4. Paper compartment

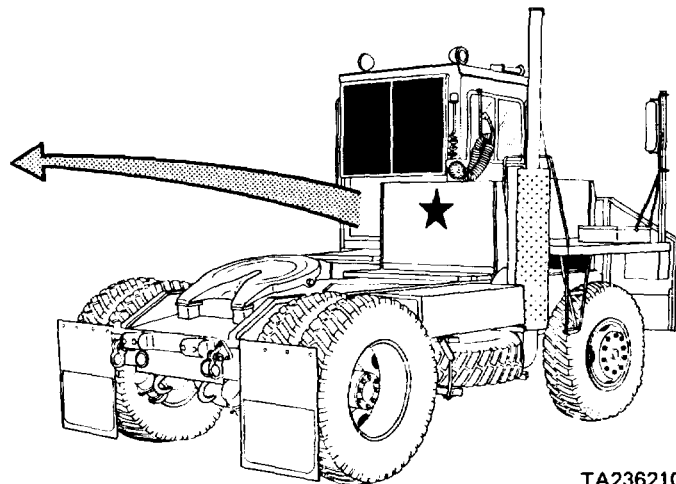
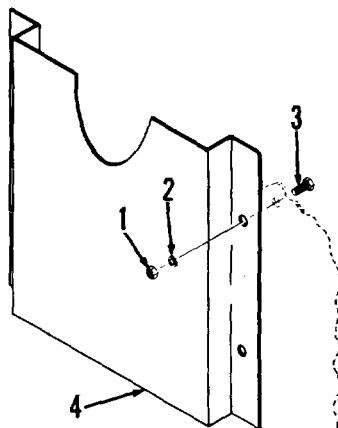

TA236210

2-65. BODY AND CAB MAINTENANCE (CONT)

m. Paper Compartment (cont).

STEP	LOCATION	ITEM	ACTION	REMARKS
REMOVAL				
1	Cab, rear wall, inside	a. Four locknuts (1), washers (2), and cap-screws (3)	Remove	Support paper compartment (4)
		b. Paper compartment (4)	Remove	

CLEANING

WARNING

Dry cleaning solvent (P-D-680), used to clean parts is toxic and flammable. Wear protective goggles and gloves and use only in a well ventilated area. Avoid contact with skin, eyes, and clothes and don't breathe vapors. Do not use near open flame or excessive heat and don't smoke when using it. Failure to do so could cause serious injury. If you become dizzy while using cleaning solvent, get fresh air and medical attention immediately. If contact with skin or clothes is made, flush with large amounts of water. If contact with eyes is made, wash eyes with water and seek medical aid immediately.

Compressed air must not exceed 30 psi. Wear safety glasses when drying parts with compressed air. Failure to do so could cause serious injury to eyes and possible blindness. If you hurt your eyes or if a foreign object is blown into your eyes, seek medical attention immediately.

2		All parts	Clean	Use cleaning solvent P-D-680; dry using compressed air. If necessary, use stiff wire brush to remove rust
---	--	-----------	-------	---

INSPECTION

3		a. Paper compartment (4)	Inspect for: cracks dents breaks	Repair dents using wooden backing block and hammer; replace if other defects are observed
---	--	--------------------------	---	---

2-65. BODY AND CAB MAINTENANCE (CONT)

m. Paper Compartment (cont).

STEP	LOCATION	ITEM	ACTION	REMARKS
INSPECTION (cont)				
3 (cont)		b. All other parts	Inspect for: thread damage distortion deformation	Replace if defects are observed
INSTALLATION				
4	Cab, rear wall, inside	a. Paper compart- ment (4) b. Four capscrews (3), washers (2), and locknuts (1)	Position Install and tighten	On rear wall; align mounting holes

2-755

2-65. BODY AND CAB MAINTENANCE (CONT)

n. Tool Box.

This task covers: a. Removal c. Inspection
 b. Cleaning d. Installation/Replacement

INITIAL SETUP

Tools

No. 1 Common Organizational Maintenance

Tool Kit

- Socket wrench set, 3/8 inch drive
- Open end wrench set
- Scratch wire brush
- Safety glasses
- Hand hammer

- Wood block, 2 by 4 by 6 inches
- Air compressor

Materials/Parts

- Cleaning solvent Item 1, Appendix C
- Clean cloths Item 2, Appendix C

Personnel Required

Wheel Vehicle Mechanic MOS 63B

Equipment Condition

Paragraph Condition Description

Vehicle parked on level surface, engine off, and parking brake applied.
 Tool box empty.

KEY

- 1. Locknuts (4)
- 2. Washers (4)
- 3. Capscrews (4)
- 4. Tool box

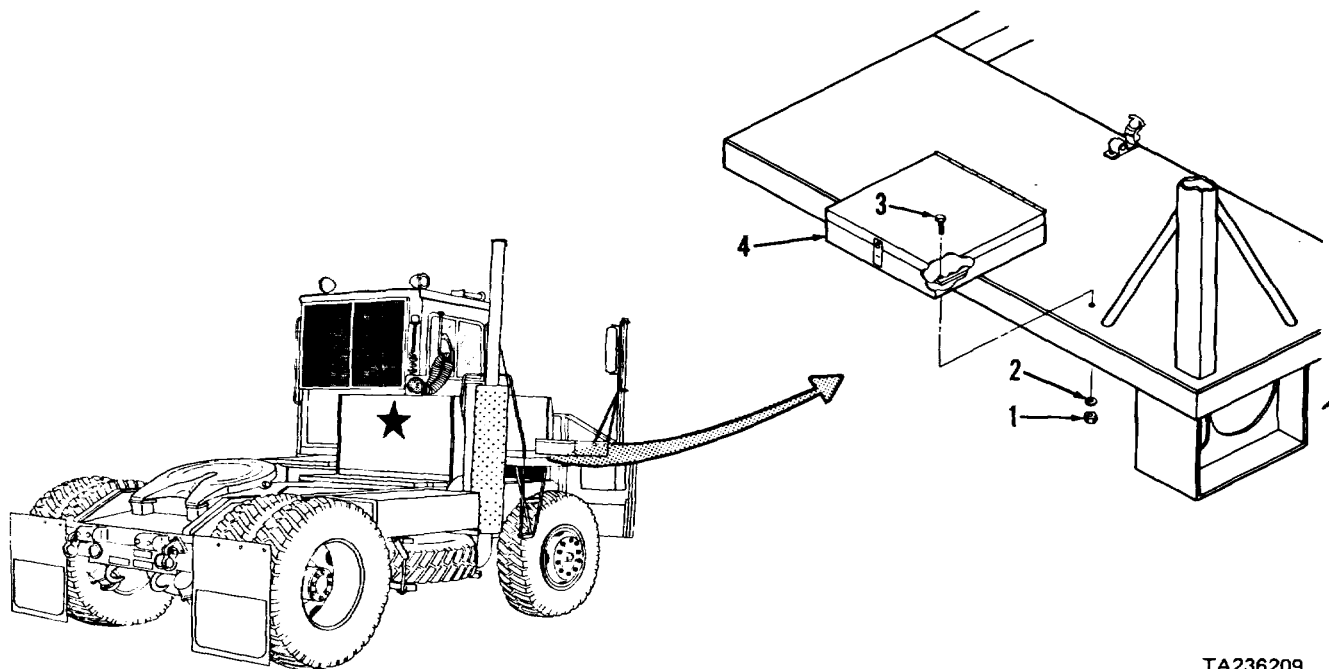

TA236209

2-65. BODY AND CAB MAINTENANCE (CONT)

n. Tool Box (cont).

STEP	LOCATION	ITEM	ACTION	REMARKS
REMOVAL				
1	Right side of vehicle, cab deck	a. Tool box (4) lid b. Four lock-Remove nuts (1), washers (2), and capscrews (3) c. Tool box (4)Remove	Open	

CLEANING

WARNING

Dry cleaning solvent (P-D-680), used to clean parts is toxic and flammable. Wear protective goggles and gloves and use only in a well ventilated area. Avoid contact with skin, eyes, and clothes and don't breathe vapors. Do not use near open flame or excessive heat and don't smoke when using it. Failure to do so could cause serious injury. If you become dizzy while using cleaning solvent, get fresh air and medical attention immediately. If contact with skin or clothes is made, flush with large amounts of water. If contact with eyes is made, wash eyes with water and seek medical aid immediately. Compressed air must not exceed 30 psi. Wear safety glasses when drying parts with compressed air. Failure to do so could cause serious injury to eyes and possible blindness. If you hurt your eyes or if a foreign object is blown into your eyes, seek medical attention immediately.

2		All parts	Clean	Use cleaning solvent P-D-680; dry using compressed air. If necessary, use a stiff wire brush to remove rust
---	--	-----------	-------	---

2-65. BODY AND CAB MAINTENANCE (CONT)
--

n. Tool Box (cont).

STEP	LOCATION	ITEM	ACTION	REMARKS
INSPECTION				
3		a. Tool box (4)	Inspect for: dents cracks breaks	Use wooden backing block to hammer out dents. Replace if other defects are observed
		b. All other parts	Inspect for: thread damage distortion deformation	Replace if defects are observed
INSTALLATION/REPLACEMENT				
4	Right side of vehicle, cab deck	a. Tool box (4) b. Four capscrews (3), washers (2), and locknuts (1)	Position Install	On cab deck, with lid open

Section X. ACCESSORIES MAINTENANCE

This section contains the information you need to maintain the accessories consisting of:

- Windshield Wiper and Arm
- Windshield Wiper Motor and Switch
- Rearview Mirror
- Sun Visor
- Windshield Washer
- Reflectors
- Heater and Defroster
- Data and Instruction Plates

It gives you instructions on how to troubleshoot problems and. repair or replace the components that are within the scope of organizational maintenance.

	Para		Para
Troubleshooting Symptom Index	2-66	Sun Visor	2-71a
Windshield Wiper and Washer		Warning Triangle	2-71b
Troubleshooting	2-67	First Aid Kit	2-71c
Heaters Troubleshooting	2-68	Air Horn Maintenance	2-72
Windshield Wiper and Washer		Heaters Maintenance	2-73
Maintenance	2-69	Cab Heater, Hoses, and	
Windshield Wiper and Arm	2-69a	Temperature Valve	2-73a
Windshield Wiper Motor and		Defroster Control, Heater	
Switch	2-69b	Temperature Control, and	
Switch	2-69b(1)	Fresh Air Control	2-73b
Windshield Wiper Motor ...	2-69b(2)	Battery Warmers	2-73c
Windshield Washer and Switch	2-69c	Engine Oil Heater	2-73d
Rearview Mirrors Maintenance	2-70	Coolant Heater and Pump	2-73e
Side Mirror	2-70a	Junction Box	2-73f
Inside Mirror	2-70b	Data and Instruction Plates	
Sun Visor, Warning Triangle,		Maintenance	2-74
and First Aid Kit	2-71		

2-66. TROUBLE SHOOTING SYMPTOM INDEX

	Para/malfunction	Page
WINDSHIELD WIPER AND WASHER		
No fluid sprayed on windshield when washer switch pressed	2-67/1	2-760
Wiper doesn't move.....	2-67/2	2-761
HEATERS		
Cab drafty	2-68/1	2-762
Fresh air door will not open or close	2-68/2	2-762
Cab heater doesn't heat cab	2-68/3	2-763
Windshield will not defrost	2-68/4	2-764
Batteries not warmed when battery warmers connected to		
power source	2-68/5	2-765
Coolant not warmed when coolant heater connected to		
power source.....	2-68/6	2-766
Engine oil heater does not operate	2-68/7	2-768
All winterization system heaters not operating	2-68/8	2-769

2-67. WINDSHIELD WIPER AND WASHER TROUBLESHOOTING
--

MALFUNCTION**TEST OR INSPECTION****CORRECTIVE ACTION****1. NO FLUID IS SPRAYED ON WINDSHIELD WHEN WASHER SWITCH IS PRESSED**

Step 1. Check if washer reservoir is full of fluid.

- a. If washer reservoir fluid level is low, fill (para 2-69c).
- b. If washer reservoir is full of fluid, go to step 2 below.

Step 2. Check if washer nozzle openings point at windshield.

- a. If washer nozzle openings do not point at windshield, adjust (para 2-69c).
- b. If washer nozzle openings point at windshield, go to step 3.

Step 3. Check windshield washer hoses and tee for fluid leaks, obstructions, and loose connections.

WARNING

Compressed air must not exceed 30 psi. Wear safety glasses when using compressed air. Failure to do so could cause serious injury to eyes and possible blindness. If you hurt your eyes or if a foreign object is blown into your eyes, seek medical aid immediately.

- a. If hoses are leaking, replace (para 2-69c); if obstructed, clean (para 2-69c).
- b. If connections are loose, tighten; if tee is obstructed, clean (para 2-69c).
- c. If hoses and tee are not leaking, obstructed, or loose, go to step 4 below.

Step 4. Check if washer nozzles are clogged.

WARNING

Compressed air must not exceed 30 psi. Wear safety glasses when using compressed air. Failure to do so could cause serious injury to eyes and possible blindness. If you hurt your eyes or if a foreign object is blown into your eyes, seek medical aid immediately.

- a. If washer nozzles are clogged, clean (para 2-69c).
- b. If washer nozzles are not clogged, go to step 5 below.

2-67. WINDSHIELD WIPER AND WASHER TROUBLESHOOTING (CONT)

MALFUNCTION**TEST OR INSPECTION****CORRECTIVE ACTION****1. NO FLUID IS SPRAYED ON WINDSHIELD WHEN WASHER SWITCH IS PRESSED (Cont)**

- Step 5. Disconnect electrical connector from washer pump (para 2-69c).
Disconnect electrical leads from washer switch and washer reservoir bracket.
Test electrical leads for continuity using ohmmeter.
- a. If continuity is not obtained, replace electrical connector with electrical leads (para 2-69c).
 - b. If continuity is obtained, go to step 6 below.
- Step 6. Install replacement washer pump and reservoir (para 2-69c).
Press washer switch.
- a. If fluid sprays on windshield, no further action required.
 - b. If fluid does not spray on windshield, replace washer switch (para 2-69c).

2. WIPER DOESN'T MOVE

- Step 1. Check wiper motor and switch hoses and fittings for air leaks and loose fittings.
- a. If hoses or fittings are leaking air, replace (para 2-69b(1) or 2-69b(2)).
 - b. If fittings are loose, tighten.
 - c. If hoses and fittings are not leaking air and are not loose, go to step 2 below.
- Step 2. Remove wiper arm and wiper blade (para 2-69a).
Check if wiper motor is operating.
- a. If wiper motor is operating, go to step 3 below.
 - b. If wiper motor is not operating, go to step 4 below.
- Step 3. Check wiper arm and wiper blade for cracks or bent condition.
Check wiper arm for weak spring.
- a. If wiper arm or wiper blade are cracked or bent, replace (para 2-69a).
 - b. If wiper arm has weak spring, replace (para 2-69a).

2-67. WINDSHIELD WIPER AND WASHER TROUBLESHOOTING (CONT)**MALFUNCTION****TEST OR INSPECTION****CORRECTIVE ACTION****2. WIPER DOESN'T MOVE (Cont)**

Step 4. Install replacement wiper motor assembly (para 2-69b(2)).
Turn wiper switch to run position.

- a. If wiper motor operates, no further action required.
- b. If wiper motor does not operate, go to step 5 below.

Step 5. Install replacement wiper switch (para 2-69b(1)).
Turn wiper switch to run position.

- a. If wiper moves, no further action required.
- b. If wiper does not move, troubleshoot air system (para 2-48).

2-68. HEATERS TROUBLESHOOTING**MALFUNCTION****TEST OR INSPECTION****CORRECTIVE ACTION****1. CAB DRAFTY**

Step 1. Check if fresh air control is pushed in fully.

- a. If fresh air control is not pushed in fully, push in fully to close heater fresh air door (prevents outside air from entering cab).
- b. If fresh air control is pushed in fully, go to step 2 below.

Step 2. Check if fresh air door is fully closed.

- a. If fresh air door is open, go to Malfunction 2 below.
- b. If fresh air door is fully closed, notify direct support maintenance.

2. FRESH AIR DOOR WILL NOT OPEN OR CLOSE

Step 1. Check fresh air door for obstructions.

- a. If obstructions are found, remove.
- b. If obstructions are not found, go to step 2 below.

2-68. HEATERS TROUBLESHOOTING (CONT)**MALFUNCTION****TEST OR INSPECTION****CORRECTIVE ACTION****2. FRESH AIR DOOR WILL NOT OPEN OR CLOSE (Cont)**

Step 2. Check if fresh air control cable engages fresh air door bellcrank.

- a. If fresh air control cable does not engage fresh air door bellcrank, reconnect (para 2-73b).
- b. If fresh air control cable engages fresh air door bellcrank, go to step 3 below.

Step 3. Check if fresh air control cable is cracked, frayed, or kinked.

- a. If fresh air control cable is cracked, frayed, or kinked, replace (para 2-73b).
- b. If fresh air control cable is not cracked, frayed, or kinked, notify direct support maintenance.

3. CAB HEATER DOESN'T HEAT CAB

Step 1. Check if temperature control cable is pulled out fully.

- a. If temperature control cable is not pulled out fully, pull out fully to allow maximum flow of hot water to cab heater.
- b. If temperature control cable is pulled out fully, go to step 2 below.

Step 2. Check if temperature control cable engages temperature valve lever.

- a. If temperature control cable does not engage temperature valve lever, reconnect (para 2-73b).
- b. If temperature control cable engages temperature valve lever, go to step 3 below.

Step 3. Check if temperature control cable is cracked, frayed, or kinked.

- a. If temperature control cable is cracked, frayed, or kinked, replace (para 2-73b).
- b. If temperature control cable is not cracked, frayed, or kinked, go to step 4 below.

2-68. HEATERS TROUBLESHOOTING (CONT)

MALFUNCTION**TEST OR INSPECTION****CORRECTIVE ACTION****3. CAB HEATER DOESN'T HEAT CAB (Cont)**

- Step 4. Remove temperature valve (para 2-73a).
Inspect temperature valve for cracks or damage.
- a. If temperature valve is cracked or damaged, replace (para 2-73a).
 - b. If temperature valve is not cracked or damaged, go to step 5 below.
- Step 5. Check cab heater hoses and clamps for leaks, obstructions, or loose connections.

WARNING

Compressed air must not exceed 30 psi. Wear safety glasses when using compressed air. Failure to do so could cause serious injury to eyes and possible blindness. If you hurt your eyes or if a foreign object is blown into your eyes, seek medical aid immediately.

- a. If connections are loose, tighten clamps; if hoses are leaking, replace (para 2-73a); if hoses are obstructed, clean using compressed air (30 psi maximum).
- b. If hoses are not leaking or obstructed, and connections are tight, notify direct support maintenance.

4. WINDSHIELD WILL NOT DEFROST

- Step 1. Check if defroster control is pulled out fully.
- a. If defroster control is not pulled out fully, pull out fully to open distributor door (directs air through windshield defroster vents).
 - b. If defroster control is pulled out fully, go to step 2 below.
- Step 2. Check windshield defroster vents for obstructions.
- a. If obstructions are found, remove.
 - b. If obstructions are not found, go to step 3 below.

2-68. HEATERS TROUBLESHOOTING (CONT)

MALFUNCTION**TEST OR INSPECTION****CORRECTIVE ACTION****4. WINDSHIELD WILL NOT DEFROST (Cont)**

Step 3. Check defroster hoses for air leaks or loose connections.

- a. If connections are loose, tighten; if defroster hoses are leaking air, replace (para 2-73a).
- b. If defroster hoses are okay, go to step 4 below.

Step 4. Check if distributor door is open.

- a. If distributor door is open, refer to Malfunction 3 above.
- b. If distributor door is not open, go to step 5 below.

Step 5. Check distributor door for obstructions.

- a. If obstructions are found, remove.
- b. If obstructions are not found, go to step 6 below.

Step 6. Check if defroster control cable engages distributor door lever.

- a. If defroster control cable does not engage distributor door lever, reconnect (para 2-73b).
- b. If defroster control cable engages distributor door lever, go to step 7 below.

Step 7. Check if defroster control cable is cracked, frayed, or kinked.

- a. If defroster control cable is cracked, frayed, or kinked, replace (para 2-73b).
- b. If defroster control cable is not cracked, frayed, or kinked, notify direct support maintenance.

5. BATTERIES NOT WARMED WHEN BATTERY WARMERS CONNECTED TO POWER SOURCE

Step 1. Check if coolant heater and engine oil heater are not operating (WATER TEMP gage indicates low and engine oil heater is cold to the touch).

- a. If coolant heater and engine oil heater are not operating, go to Malfunction 8 below.
- b. If coolant or engine oil heater are operating, go to step 2.

2-68. HEATERS TROUBLESHOOTING (CONT)

MALFUNCTION**TEST OR INSPECTION****CORRECTIVE ACTION****5. BATTERIES NOT WARMED WHEN BATTERY WARMERS CONNECTED TO POWER SOURCE (Cont)**

- Step 2. Connect power cord between junction box and 110 Vac outlet.
Check if both battery warmers are cold.

WARNING

Battery warmers operate from 110 Vac power source. Disconnect winterization system cable from receptacle at front bumper of tractor before proceeding. Serious injury or death can result from contact with energized 110 Vac power lines.

Disconnect power cord from junction box and 110 Vac outlet.

- a. If both battery warmers are cold, go to step 4 below.
- b. If only one battery warmer is cold, go to step 3 below.

- Step 3. Check for loose connection at wire nuts connecting battery warmer 3-wire cord to 3-wire cord from junction box.

- a. If connection is loose, reconnect (para 2-73c).
- b. If connection is not loose, replace battery warmer (para 2-73c).

- Step 4. Use an ohmmeter to check continuity of 3-wire cord between battery warmers and junction box.

- a. If continuity is not obtained, replace 3-wire cord (para 2-73c).
- b. If continuity is obtained, replace battery warmers (para 2-73c).

6. COOLANT NOT WARMED WHEN COOLANT HEATER CONNECTED TO POWER SOURCE

- Step 1. Check if engine oil heater and battery warmers are not operating (engine oil heater and battery warmers cold to the touch).

- a. If engine oil heater and battery warmers are not operating, go to Malfunction 8 below.
- b. If engine oil heater or battery warmers are operating, go to step 2 below.

2-68. HEATERS TROUBLESHOOTING (CONT)

MALFUNCTION**TEST OR INSPECTION****CORRECTIVE ACTION****6. COOLANT NOT WARMED WHEN COOLANT HEATER CONNECTED TO POWER SOURCE (Cont)**

- Step 2. Connect power cord between junction box and 110 Vac outlet.
Check if heater pump is operating (a slight buzz should be heard, indicating heater pump is operating).

WARNING

Coolant heater operates from 110 Vac power source. Disconnect winterization system cable from receptacle at front bumper of tractor before proceeding. Serious injury or death can result from contact with energized 110 Vac power lines.

Disconnect power cord from 110 Vac outlet and junction box.

- a. If heater pump buzzes, go to step 3 below.
 - b. If heater pump does not buzz, go to step 7 below.
- Step 3. Remove coolant heater thermostat cover (para 2-73e).
Use an ohmmeter to check continuity of 3-wire cord between thermostat and junction box (para 2-73f).
- a. If continuity is not obtained, replace 3-wire cord (para 2-73e).
 - b. If continuity is obtained, go to step 4 below.
- Step 4. Disconnect 3-wire cord from coolant heater thermostat (para 2-73e).
Use an ohmmeter to check continuity of thermostat.
- a. If continuity is not obtained, replace thermostat (para 2-73e).
 - b. If continuity is obtained, go to step 5 below.
- Step 5. Disconnect 3-wire cord from coolant heater unit (para 2-73e).
Check continuity of heater element.
- a. If continuity is not obtained, replace coolant heater unit or element (para 2-73e).
 - b. If continuity is obtained, go to step 6 below.

2-68. HEATERS TROUBLESHOOTING (CONT)

MALFUNCTION**TEST OR INSPECTION****CORRECTIVE ACTION****6. COOLANT NOT WARMED WHEN COOLANT HEATER CONNECTED TO POWER SOURCE (Cont)**

Step 6. Use an ohmmeter to check for continuity of 3-wire cord between coolant heater thermostat and coolant heater element.

- a. If continuity is not obtained, replace 3-wire cord (para 2-73e).
- b. If continuity is obtained, go to step 7 below.

Step 7. Remove coolant heater thermostat cover (para 2-73e).

Use an ohmmeter to check for continuity of 3-wire cord between coolant heater pump and coolant heater thermostat.

- a. If continuity is obtained, replace coolant pump (para 2-73e).
- b. If continuity is not obtained, replace 3-wire cord (para 2-73e).

7. ENGINE OIL HEATER DOES NOT OPERATE

Step 1. Check if coolant heater and battery warmers are not operating (WATER TEMP gage indicates low and battery warmers cold to the touch).

- a. If coolant heater and battery warmers are not operating, go to Malfunction 8 below.
- b. If coolant heater or battery warmers are operating, go to step 2 below.

WARNING

Engine oil heater operates from 110 Vac power source. Disconnect winterization system cable from receptacle at front bumper of tractor before proceeding. Serious injury or death can result from contact with energized 110 Vac power lines.

Step 2. Use an ohmmeter to check for continuity of 3-wire cord between engine oil heater and junction box (para 2-73f).

- a. If continuity is not obtained, replace 3-wire cord (para 2-73d).
- b. If continuity is obtained, go to step 3 below.

2-68. HEATERS TROUBLESHOOTING (CONT)

MALFUNCTION**TEST OR INSPECTION****CORRECTIVE ACTION****7. ENGINE OIL HEATER DOES NOT OPERATE (Cont)**

Step 3. Remove and disassemble engine oil heater (para 2-73d).
Use an ohmmeter to check for continuity of engine oil heater electrical leads.

- a. If continuity is not obtained, replace electrical leads (para 2-73d).
- b. If continuity is obtained, go to step 4 below.

Step 4. Use an ohmmeter to check for continuity of engine oil heater heating element.

- a. If continuity is not obtained, replace heating element (para 2-73d).
- b. If continuity is obtained, replace engine oil heater (para 2-73d).

8. ALL WINTERIZATION SYSTEM HEATERS NOT OPERATING**WARNING**

Winterization system heaters operate from 110 Vac power source. Disconnect winterization system cable from receptacle at front bumper of tractor before proceeding. Serious injury or death can result from contact with energized 110 Vac power lines.

Check if junction box connector insert is cracked or damaged.
Check if cord set wires are securely connected to connector insert.

- a. If cord set wire connections are loose, reconnect (para 2-73f).
- b. If connector insert is cracked or damaged, replace (para 2-73f).

2-69. WINDSHIELD WIPER AND WASHER MAINTENANCE

a. Windshield Wiper and Arm.

This task covers: a. Removal c. Inspection
 b. Cleaning d. Installation/Replacement

INITIAL SETUP

Tools

No. 1 Common Organizational Maintenance
 Tool Kit
 Adjustable open end wrench
 Pliers
 Drift punch

Materials/Parts

Cleaning solvent Item 1, Appendix C
 Clean cloths Item 2, Appendix C
 Detergent Item 27, Appendix C

Personnel Required

Wheel Vehicle Mechanic MOS 63B

Equipment Condition

Paragraph Condition Description

Vehicle parked on level surface, engine off, and parking brake applied.

KEY

1. Screw
2. Wiper blade
3. Capnut
4. Lock washer
5. Wiper arm
6. Knurled driver
7. Rain shield

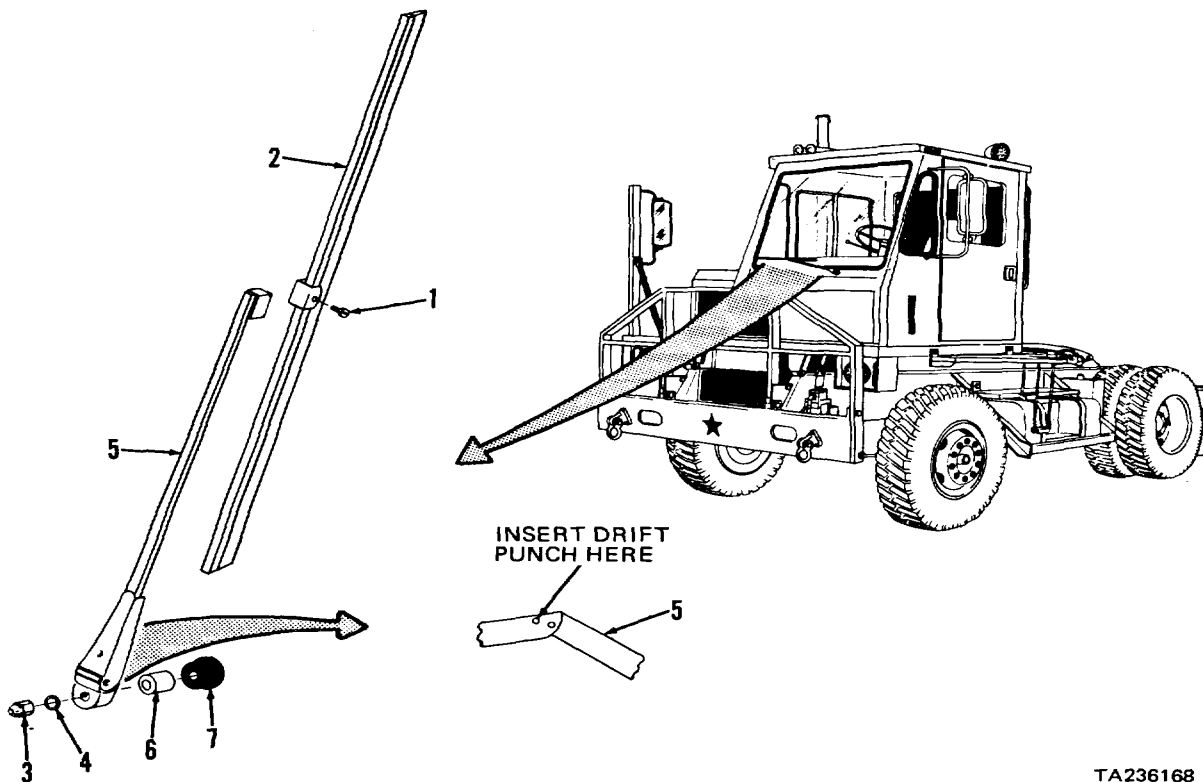

TA236168

2-69. WINDSHIELD WIPER AND WASHER MAINTENANCE (CONT)

- a. Windshield Wiper and Arm (cont).

STEP	LOCATION	ITEM	ACTION	REMARKS
REMOVAL				
1	Front of vehicle, windshield	a. Wiper arm (5)	Move	Pull away from windshield and insert small drift punch in hole at base of wiper arm to hold wiper arm away from windshield
		b. Screw (1)	Remove	Support wiper blade (2)
		c. Wiper blade (2)	Remove	
		d. Capnut (3) and lock washer (4)	Remove	
		e. Wiper arm (5)	Remove	Pull from motor shaft
		f. Knurled driver (6)	Remove	If necessary
		g. Rain shield (7)	Remove	If necessary

CLEANING

WARNING

Dry cleaning solvent (P-D-680), used to clean parts is toxic and flammable. Wear protective goggles and gloves and use only in a well ventilated area. Avoid contact with skin, eyes, and clothes and don't breathe vapors. Do not use near open flame or excessive heat and don't smoke when using it. Failure to do so could cause serious injury. If you become dizzy while using cleaning solvent, get fresh air and medical attention immediately. If contact with skin or clothes is made, flush with large amounts of water. If contact with eyes is made, wash eyes with water and seek medical aid immediately.

2	a. Wiper blade (2)	Clean	Use clean cloth moistened with cleaning solvent to clean metal parts of blade. Use clean cloth to clean other parts of blade
	b. Rain shield (7)	Clean	Use clean cloth moistened with detergent
	c. All other parts	Clean	Use cleaning solvent P-D-680; dry with clean cloths

2-69. WINDSHIELD WIPER AND WASHER MAINTENANCE (CONT)

a. Windshield Wiper and Arm (cont).

STEP	LOCATION	ITEM	ACTION	REMARKS
INSPECTION				
3		a. Wiper blade (2)	Inspect for: cracks breaks chipping	Replace if defects are observed
		b. Wiper arm (5)	Inspect for: bent condition cracks weak spring	Replace if defects are observed
		c. Knurled driver (6)	Inspect for: cracks worn or chipped splines	Replace if defects are observed
		d. Rain shield (7)	Inspect for: cracks breaks deformation	Replace if defects are observed
		e. All other parts	Inspect for: thread damage distortion deformation	Replace if defects are observed
INSTALLATION/REPLACEMENT				
4	Front of vehicle, windshield	a. Rain shield (7)	Install	On wiper motor shaft
		b. Knurled driver (6)	Install	
		c. Wiper arm (5)	Install	Press on knurled driver (6); be sure wiper arm is positioned in parked position
		d. Lock washer (4) and capnut (3)	Install	On wiper arm (5)
		e. Wiper blade (2)	Position	

2-69. WINDSHIELD WIPER AND WASHER MAINTENANCE (CONT)

a. Windshield Wiper and Arm (cont).

STEP	LOCATION	ITEM	ACTION	REMARKS
INSTALLATION/REPLACEMENT (cont)				
4 (cont)		f. Screw (1)	Install	Do not tighten
		g. Wiper arm (5)	Move	Pull away from windshield and remove drift punch; then slowly position wiper blade (2) on windshield
		h. Wiper blade (2)	Adjust	Position so wiper blade (2) does not travel below windshield
		i. Screw (1)	Tighten	Secures adjustment

2-773

2-69. WINDSHIELD WIPER AND WASHER MAINTENANCE (CONT)

b. Windshield Wiper Motor and Switch.

(1) Switch.

This task covers: a. Removal c. Inspection
 b. Cleaning d. Installation/Replacement

INITIAL SETUP

Tools

No. 1 Common Organizational Maintenance

Tool Kit

Open end wrench set

Bent trimmer's shears

Pliers, round nose

Personnel Required

Wheel Vehicle Mechanic MOS 63B

Equipment Condition

Paragraph Condition Description

Materials/Parts

Cleaning solvent	Item 1,	Appendix C	
Clean cloths	Item 2,	Appendix C	2-34b
Tags	Item 14,	Appendix C	
Detergent	Item 27,	Appendix C	2-26g(1)
Hose	FSCM 85757 PN 4246-0410		2-41h(1)

Vehicle parked on level surface, engine off, and parking brake applied.

Battery ground cable disconnected.

Instrument panel raised.

All air pressure relieved.

STEP	LOCATION	ITEM	ACTION	REMARKS
REMOVAL				
1	Instrument panel, left side	a. Setscrew (5) b. Knob (6) c. Nut (7) and lock washer (8) d. Wiper control (9)	Loosen Remove Remove	Pull from wiper control (9) Support wiper control (9)
2	Wiper control (9)	a. Three hoses (1 thru 3) b. Three elbows (4)	a. Tag b. Disconnect	Loosen elbow (4) nut, slide nut onto hose, then hose from elbow From wiper control (9)
3	Cab wall, right side	a. Hose (1) b. Fitting (10)	a. Tag b. Disconnect	Loosen fitting (10) nut, slide nut onto hose, then pull hose from fitting Only if necessary

2-69. WINDSHIELD WIPER AND WASHER MAINTENANCE (CONT)

b. Windshield Wiper Motor and Switch (cont).

(1) Switch (cont).

KEY

- 1. Hose
- 2. Hose
- 3. Hose
- 4. Elbows (3)
- 5. Setscrew
- 6. Knob
- 7. Nut
- 8. Lock washer
- 9. Wiper control
- 10. Fitting

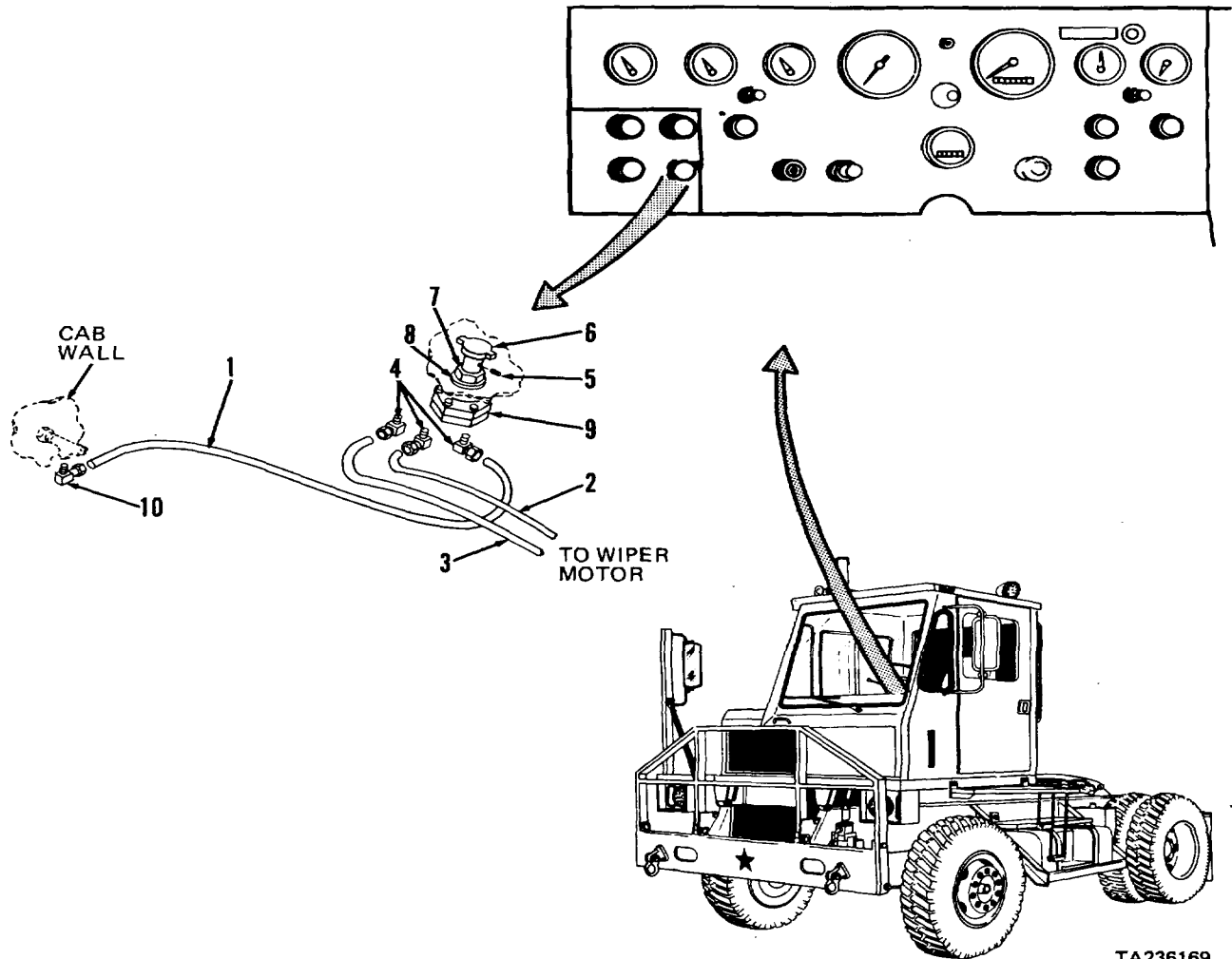

2-69. WINDSHIELD WIPER AND WASHER MAINTENANCE (CONT)

b. Windshield Wiper Motor and Switch (cont).

(1) Switch (cont).

STEP	LOCATION	ITEM	ACTION	REMARKS
CLEANING 4	a.	Three hoses (1 thru 3) and knob (6)	Clean	Use clean cloth moistened with detergent; dry using clean cloths

WARNING

Dry cleaning solvent (P-D-680), used to clean parts is toxic and flammable. Wear protective goggles and gloves and use only in a well ventilated area. Avoid contact with skin, eyes, and clothes and don't breathe vapors. Do not use near open flame or excessive heat and don't smoke when using it. Failure to do so could cause serious injury. If you become dizzy while using cleaning solvent, get fresh air and medical attention immediately. If contact with skin or clothes is made, flush with large amounts of water. If contact with eyes is made, wash eyes with water and seek medical aid immediately.

	b.	All other parts	Clean	Use cleaning solvent P-D-680; dry using clean cloths
INSPECTION 5	a.	Three hoses (1 thru 3)	Inspect for: cracks breaks deteriora- tion holes	Replace if defects are observed. If replacement is required, cut new hose (1) 20 inches long, new hose (2) 20-1/2 inches long, and new hose (3) 13 inches long

NOTE

See para 2-69b(2) for procedures to disconnect other end of hoses (2 and 3) if replacement of these hoses is necessary.

	b.	Three elbows (4) and fitting (10)	Inspect for: thread damage cracks breaks	Replace if defects are observed
--	----	---	--	------------------------------------

2-69. WINDSHIELD WIPER AND WASHER MAINTENANCE (CONT)

b. Windshield Wiper Motor and Switch (cont).

(1) Switch (cont).

STEP	LOCATION	ITEM	ACTION	REMARKS
INSPECTION (cont)				
5 (cont)		c. Knob (6)	Inspect for: cracks chipping	Replace if defects are observed
		d. All other parts	Inspect for: thread damage distortion deformation	Replace if defects are observed
INSTALLATION/REPLACEMENT				
6	Cab wall, right side	a. Fitting (10)	Install	In tee Connect by removing fitting (10) nut and ferrule. Slide nut onto hose (1), then install ferrule on end of hose. Insert ferrule and hose into fitting (10), then tighten nut
		b. Hose (1)	Connect	
7	Wiper control (9)	a. Three elbows (4)	Install	In wiper control (9) ports
		b. Three hoses (1 thru 3)	Connect	Connect hose (1) to IN port of wiper control (9); connect hose (2) to RUN port; connect hose (3) to PARK port. Connect by removing elbow (4) nut and ferrule. Slide nut onto hose, then install ferrule on end of hose. Insert ferrule and hose into elbow (4) and tighten nut
8	Instrument panel, left side	a. Wiper control (9) with hoses (1, 2, and 3)	Position	From bottom of instrument panel

2-69. WINDSHIELD WIPER AND WASHER MAINTENANCE (CONT)

b. Windshield Wiper Motor and Switch (cont).

(1) Switch (cont).

STEP	LOCATION	ITEM	ACTION	REMARKS
INSTALLATION/REPLACEMENT (cont)				
8 (cont)		b. Nut (7) and lock washer (8)	Install	Secures wiper control (9)
		c. Knob (6)	Install	On shaft of wiper control (9)
		d. Setscrew (5)	Tighten	Secures knob (6)
9	Cab	Instrument panel	Lower and secure	Para 2-26g(1)
10	Battery box	Battery ground cable	Connect	Para 2-34b
11	Tractor	Air pressure	Restore	Para 2-41h(1)

2-778

2-69. WINDSHIELD WIPER AND WASHER MAINTENANCE (CONT)

b. Windshield Wiper Motor and Switch (cont).

(2) Windshield Wiper Motor.

This task covers: a. Removal c. Inspection
 b. Cleaning d. Installation/Replacement

INITIAL SETUP

Tools

No. 1 Common Organizational Maintenance Tool Kit
 Open end wrench set
 Bent trimmer's shears

Equipment Condition

Paragraph Condition Description

Materials/Parts

Cleaning solvent	Item 1,	Appendix C	2-69a
Clean cloths	Item 2,	Appendix C	2-41h(1)
Tags	Item 14,	Appendix C	2-26g(1)
Detergent	Item 27,	Appendix C	2-34a
Hose	FSCM 85757 PN 4246-0410		
Leather washer	FSCM 60703 PN 2355-2		

Vehicle parked on level surface, engine off, and parking brake applied.
 Windshield wiper and arm removed.
 All air pressure relieved.
 Instrument panel raised.
 Battery ground cable disconnected.

Personnel Required

Wheel Vehicle Mechanic MOS 63B

KEY

1. Nut
2. Washer
3. Leather washer
4. Hose
5. Hose
6. Fitting
7. Elbow
8. Elbow
9. Capscrews (2)
10. Nuts (2)
11. Plate and bushing
12. Wiper motor assembly
13. Shaft

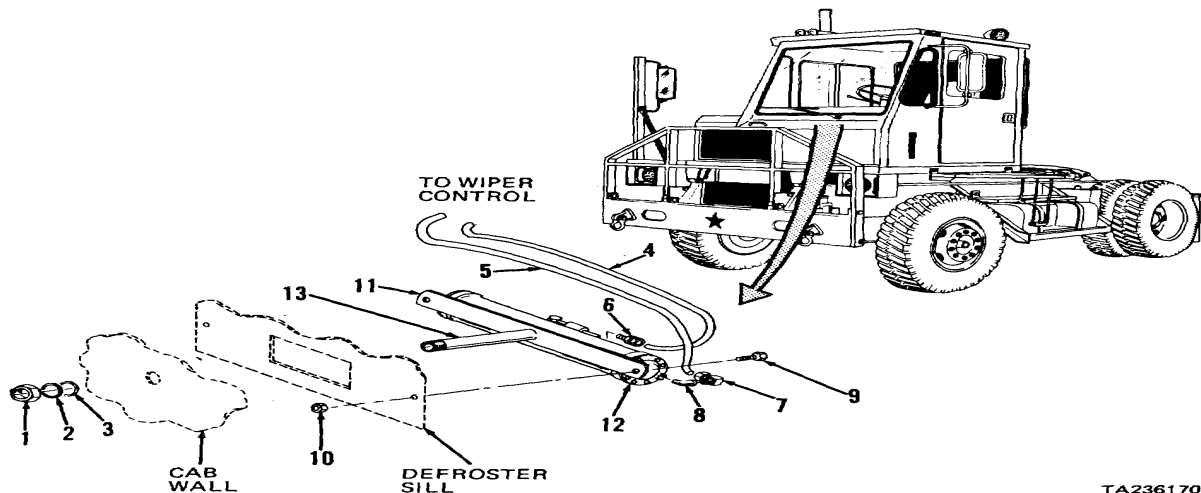

2-69. WINDSHIELD WIPER AND WASHER MAINTENANCE (CONT)

b. Windshield Wiper Motor and Switch (cont).

(2) Windshield Wiper Motor.

STEP	LOCATION	ITEM	ACTION	REMARKS
REMOVAL				
1	Windshield, vehicle front	Nut (1), washer (2), and leather washer (3)	Remove	Discard leather washer (3)
2	Instrument panel, left side, underside	a. Two hoses (4 and 5)	Tag and disconnect	Disconnect by loosening elbow (7) or fitting (6) nut, slide nut onto hose, then pull hose from elbow or fitting
		b. Fitting (6)	Remove	From wiper motor assembly (12)
		c. Elbows (7 and 8)	Remove	
		d. Two capscrews (9) and (12) nuts (10)	Remove	Support wiper motor assembly
		e. Plate and bushing (11) and wiper motor assembly (12)	Remove	Remove wiper motor by lowering and withdrawing
CLEANING				
3	a.	Two hoses (4 and 5)	Clean	Use clean cloth moistened with detergent; dry with clean cloths

WARNING

Dry cleaning solvent (P-D-680), used to clean parts is toxic and flammable. Wear protective goggles and gloves and use only in a well ventilated area. Avoid contact with skin, eyes, and clothes and don't breathe vapors. Do not use near open flame or excessive heat and don't smoke when using it. Failure to do so could cause serious injury. If you become dizzy while using cleaning solvent, get fresh air and medical attention immediately. If contact with skin or clothes is made, flush with large amounts of water. If contact with eyes is made, wash eyes with water and seek medical aid immediately.

2-69. WINDSHIELD WIPER AND WASHER MAINTENANCE (CONT)

b. Windshield Wiper Motor and Switch (cont).

(2) Windshield Wiper Motor.

STEP	LOCATION	ITEM	ACTION	REMARKS
CLEANING (cont)				
3 (cont)		b. All other parts except leather washer (3)	Clean	Use cleaning solvent P-D-680; dry with clean cloths
INSPECTION				
4		a. Two hoses (4 and 5)	Inspect for: cracks breaks	Replace if defects are observed. If replacement is required, use FSCM 85757
PN		b. Plate and bushing (11), wiper motor assembly (12), and shaft (13)	deterioration holes Inspect for: cracks breaks bent condition deformation thread damage	4246-0410. Hose (4) is 20-1/2 inches long; hose (5) is 13 inches long Replace if defects are observed
		c. Elbows (7 and 8) and fitting (6)	Inspect for: thread damage cracks breaks	Replace if defects are observed
		d. All other parts	Inspect for: thread damage distortion deformation	Replace if defects are observed
INSTALLATION/REPLACEMENT				
5	Instrument panel, left side, underside	a. Wiper motor assembly (12) and shaft (13)	Position	
		b. Two capscrews (9) and nuts (10)	Install	
		c. Elbows (7 and 8)	Install	

2-69. WINDSHIELD WIPER AND WASHER MAINTENANCE (CONT)

b. Windshield Wiper Motor and Switch (cont).

(2) Windshield Wiper Motor (cont).

STEP	LOCATION	ITEM	ACTION	REMARKS
INSTALLATION/REPLACEMENT (cont)				
5 (cont)		d. Fitting (6) e. Two hoses (4 and 5)	Install Connect	Connect by removing elbow (7) or fitting (6) nut and ferrule. Slide nut onto hose, then install ferrule on end of hose. Insert ferrule and hose into elbow (7) or fitting (6), then tighten nut securely
6	Windshield, vehicle front	New leather washer (3), washer (2), and nut (1)	Install	Tighten nut (1)
7	Cab	Instrument panel	Lower and secure	Para 2-26g(1)
8	Battery box	Battery ground cable	Connect	Para 2-34a
9	Tractor	Air pressure	Restore	Para 2-41h(1)

NOTE

Check operation by placing wiper control in run position and check that windshield wiper motor operates.

10	Windshield, vehicle front	Windshield wiper arm and wiper	Install	Para 2-69a
----	---------------------------------	-----------------------------------	---------	------------

2-69. WINDSHIELD WIPER AND WASHER MAINTENANCE (CONT)

c. Windshield Washer and Switch.

- This task covers:
- a. Removal
 - b. Cleaning
 - c. Inspection
 - d. Installation
 - e. Adjustment

INITIAL SETUP

Tools

No.	1 Common Organizational Maintenance	Isopropyl alcohol	Item 42, Appendix C
Tool Kit		Hose	FSCM 60703 PN 74-316
	Socket wrench set, 3/8 inch drive	Tie straps	FSCM 96906
	Open end wrench set		PN MS3667-1-9
	Safety glasses		
	Flat tip screwdriver		
	Multimeter		
	Bent trimmer's shears		
	Crimping tool		
	Air compressor		

Personnel Required

Wheel Vehicle Mechanic MOS 63B

Equipment Condition

Paragraph Condition Description

Materials/Parts

Cleaning solvent	Item 1,	Appendix C		Vehicle parked on level surface, engine off, and parking brake applied.
Clean cloths	Item 2,	Appendix C		
Detergent	Item 27,	Appendix C		Instrument panel raised.
Denatured alcohol	Item 30,	Appendix C	2-26g(1)	Engine hood opened.
Ink, marking stencil, white	Item 32,	Appendix C	2-65f	Cab grille removed.
Tape, electrical	Item 37,	Appendix C	2-73a	Defroster hoses removed.

STEP	LOCATION	ITEM	ACTION	REMARKS
------	----------	------	--------	---------

REMOVAL

1	Engine compartment, rear grille	a.	Electrical connector (1)	Disconnect	From washer pump and reservoir (7)
		b.	Hose (2)	Disconnect	From washer pump and reservoir (7)
		c.	Two locknuts (3), washers (4), and capscrews (5)	Remove	Support washer pump and reservoir (7)
		d.	Terminal (6)	Disconnect	From capscrew (5)
		e.	Washer pump and reservoir (7)	Remove	From engine compartment
2	Front of cab, inside engine compartment	a.	Hose (2)	Disconnect and remove	From tee (11). Remove hose (2) only if inspection indicates replacement is necessary; cut and remove tie straps as required

2-69. WINDSHIELD WIPER AND WASHER MAINTENANCE (CONT)

c. Windshield Washer and Switch (cont).

KEY

- 1. Electrical connector
- 2. Hose
- 3. Locknuts (2)
- 4. Washers (2)
- 5. Capscrews (2)
- 6. Terminal
- 7. Washer pump and
- 8. Grommet
- 9. Hose
- 10. Hose
- 11. Tee
- 12. Wing nuts (2)
- 13. Washer nozzles (2)
- 14. Rubber washers (2)
- 15. Electrical lead (BRN/BLU)
- 16. Electrical lead (ORG/WHT)
- 17. Round nut
- 18. Nut
- 19. Switch
- 20. Plate
- 21. Screws (2)

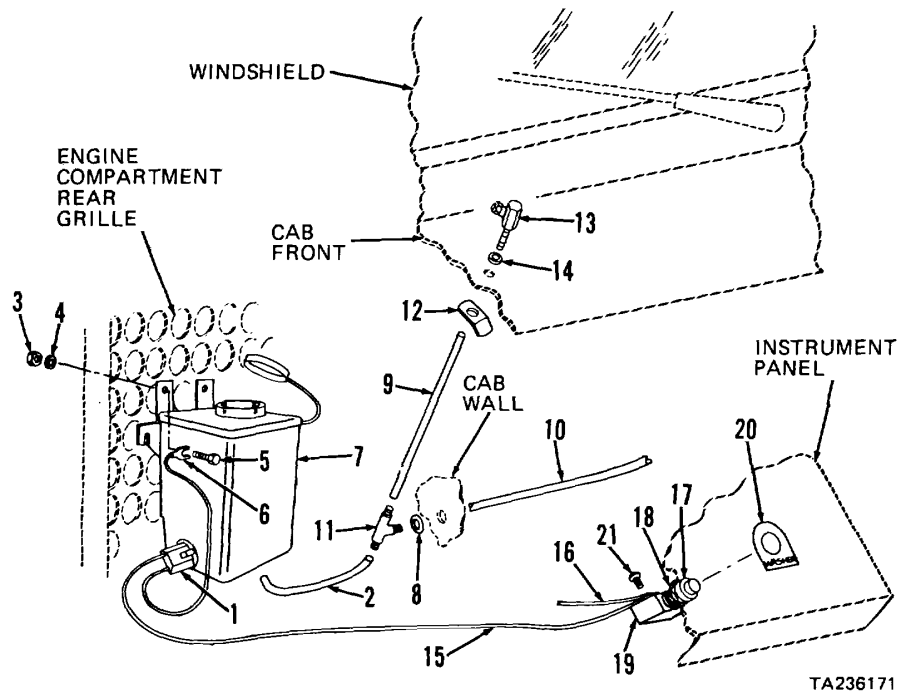

STEP	LOCATION	ITEM	ACTION	REMARKS
------	----------	------	--------	---------

REMOVAL (cont)

2
(cont)

- b. Two hoses (9 and 10) Disconnect From tee (11); then remove tee
- c. Grommet (8) Remove
- d. Hoses (9 and 10) Disconnect From washer nozzles (13). Remove hoses (9 and 10) only if necessary for replacement; cut and remove tie straps as required
- e. Two wing nuts Remove Have assistant hold driver's (12)side nozzle (13)
- f. Two washer nozzles (13) and rubber washers (14) Remove

2-69. WINDSHIELD WIPER AND WASHER MAINTENANCE (CONT)

c. Windshield Washer and Switch (cont).

STEP	LOCATION	ITEM	ACTION	REMARKS
REMOVAL (cont)				
3	Cab interior, instrument panel, lower right side	a. Round nut (17)	Remove	Support switch (19) Pull from bottom of instrument panel
		b. Switch (19) with nut (18) and electrical leads (15 and 16)	Remove	
		c. Electrical leads (15 and 16)	Tag	
		d. Two screws (21)	Remove	
		e. Electrical leads (15 and 16)	Disconnect	From switch (19) terminals
		f. Plate (20)	Remove	Only if necessary for replacement; use a sharp instrument such as a razor blade, slip it under one corner of plate, then pull up on plate to remove
CLEANING				
4		a. Hoses (2, 9, and 10), tee (11), washer nozzles (13), washer pump and reservoir (7)	Clean	Use solution of clean water and detergent. Rinse with clean water and allow to air dry
		b. Switch (19), electrical connector (1), terminal (6), and electrical leads (15 and 16)	Clean	Use clean cloth moistened with denatured alcohol

2-69. WINDSHIELD WIPER AND WASHER MAINTENANCE (CONT)

c. Windshield Washer and Switch (cont).

STEP	LOCATION	ITEM	ACTION	REMARKS
------	----------	------	--------	---------

CLEANING (cont)

4
(cont)

WARNING

Dry cleaning solvent (P-D-680), used to clean parts is toxic and flammable. Wear protective goggles and gloves and use only in a well ventilated area. Avoid contact with skin, eyes, and clothes and don't breathe vapors. Do not use near open flame or excessive heat and don't smoke when using it. Failure to do so could cause serious injury. If you become dizzy while using cleaning solvent, get fresh air and medical attention immediately. If contact with skin or clothes is made, flush with large amounts of water. If contact with eyes is made, wash eyes with water and seek medical aid immediately.

c.	Remaining metal parts	Clean	Use cleaning solvent P-D-680; dry using clean cloths
----	-----------------------	-------	--

INSPECTION

WARNING

Wear safety glasses when checking parts using compressed air. Failure to do so could cause serious injury to eyes and possible blindness. If you hurt your eyes or if a foreign object is blown into your eyes, obtain medical attention immediately.

5

a.	Hoses (2, 9, and 10), tee (11), and nozzles (13)	Inspect for: obstructions cuts cracks	Use compressed air at approximately 15 psi. Replace if obstructed or other defects observed. Use FSCM 60703
----	--	--	---

PN

b.	Electrical connector (1)	deterioration Inspect for: cracked phenolic material loose or frayed wires	74-316 for hose replacement Replace if cracked or if wires are loose. Repair frayed wiring by taping with electrical tape
----	--------------------------	---	--

2-69. WINDSHIELD WIPER AND WASHER MAINTENANCE (CONT)

c. Windshield Washer and Switch (cont).

STEP	LOCATION	ITEM	ACTION	REMARKS
INSPECTION (cont)				
5 (cont)		c. Washer pump and reservoir (7)	Inspect for: foreign material buildup cracks holes	Replace if any defects are observed. Set multimeter to X1 ohms range and check continuity of washer pump; replace if continuity not obtained
		d. Switch (19)	Inspect for: broken or cracked phenolic loose or broken terminals	Replace if any defects are observed
		e. Electrical leads (15 and 16)	Inspect for: frayed insulation loose terminals	Repair frayed or cracked insulation using electrical tape. Crimp loose terminals
		f. Plate (20)	Inspect for: obliterated lettering	Touch up lettering using white marking ink
		g. All threaded parts	Inspect for: damaged threads distortion deformation	Replace if defects are observed
INSTALLATION				
6	Cab interior instrument panel lower right side	a. Plate (20)	Install	Peel off protective backing paper; position plate over mounting hole and press in position
		b. Electrical leads (15 and 16)	Connect	To switch (19) terminals; as tagged during removal
		c. Two screws (21)	Install and tighten	Secures electrical leads (15 and 16)

2-69. WINDSHIELD WIPER AND WASHER MAINTENANCE (CONT)

c. Windshield Washer and Switch (cont).

STEP	LOCATION	ITEM	ACTION	REMARKS
INSTALLATION (cont)				
6 (cont)		d. Switch (19) with nut (18) and electrical leads (15 and 16)	Position	In mounting hole from bottom of instrument panel
		e. Round nut (17)	Install and tighten	Secures switch (19)
7	Front of cab inside engine compartment	a. Rubber washers (14)	Install	On washer nozzles (13)
		b. Washer nozzles (13)	Position	In holes in cab front
		c. Wing nuts (12)	Install and tighten	One on each washer nozzle (13); have assistant hold driver's side nozzle (13)
		d. Hoses (9 and 10)	Connect	Push onto washer nozzles (13)
		e. Grommet (8)	Install	
		f. Three hoses (2 9 and 10)	Connect	To tee (11); if hose was removed route hose and install tie straps as required
8	Engine compartment rear grille	a. Washer pump and reservoir (7)	Position	On rear grille
		b. Terminal (6) two capscrews (5) washers (4) and locknuts (3)	Install and tighten	
		c. Hose (2)	Connect	To washer pump and reservoir (7)
		d. Electrical connector (1)	Connect	To washer pump and reservoir (7)
		e. Washer pump and reservoir (7)	Fill	Use solution of 50 percent isopropyl alcohol and 50 percent water

2-69. WINDSHIELD WIPER AND WASHER MAINTENANCE (CONT)

c. Windshield Washer and Switch (cont).

STEP	LOCATION	ITEM	ACTION	REMARKS
ADJUSTMENT				
9	Instrument panel	Washer switch (19)	Depress	Check that solution strikes windshield in approximate center; if necessary to adjust perform step 10 below
10	Front of cab inside engine compartment	a. Wing nut (12)	Loosen	To direct spray into center of windshield wiper path Secures adjustment
		b. Washer nozzle (13)	Adjust	
		c. Wing nut (12)	Tighten	

NOTE

Perform step 10 above to adjust remaining washer nozzle(13) if necessary.

11	Engine compartment	a. Defroster hoses	Install	Para 2-73a
		b. Engine hood	Close and secure	Para 2-65f
		c. Cab grille	Install	Para 2-65h
12	Cab	Instrument panel	Lower and secure	Para 2-26g(1)

2-70. REARVIEW MIRRORS MAINTENANCE

a. Side Mirrors.

This task covers:

- a. Removal
- b. Disassembly
- c. Cleaning
- d. Inspection
- e. Reassembly
- f. Installation

INITIAL SETUP

Tools

No. 1 Common Organizational Maintenance

Tool Kit

- Socket wrench set 3/8 inch drive
- Open end wrench set

Personnel Required

Wheel Vehicle Mechanic MOS 63B

Equipment Condition

Paragraph Condition Description

Materials/Parts

- Cleaning solvent Item 1 Appendix C
- Clean cloths Item 2 Appendix C
- Detergent Item 27 Appendix C

Vehicle parked on level surface engine off and parking brake applied.

STEP	LOCATION	ITEM	ACTION	REMARKS
------	----------	------	--------	---------

REMOVAL

1	Vehicle front right side	a. Four locknuts (1) and capscrews (2)	Remove	Support mounting tube (13) and mirror (14)
		b. Mounting tube (13) and mirror (14)	Remove	
2	Vehicle front left side	a. Four capscrews (2) and lock washers (3)	Remove	Support mounting tube (13) and mirror (14)
		b. Mounting tube (13)	Remove	

DISASSEMBLY

3	Mirror left hand side	a. Two nuts (4) lock washers (5) and capscrews (6)	Remove	Support mounting brackets (7)
		b. Two mounting brackets (7)	Remove	
		c. Four nuts (8) lock washers (9) and capscrews (10)	Remove	

2-70. REARVIEW MIRRORS MAINTENANCE (CONT)

a. Side Mirrors (cont).

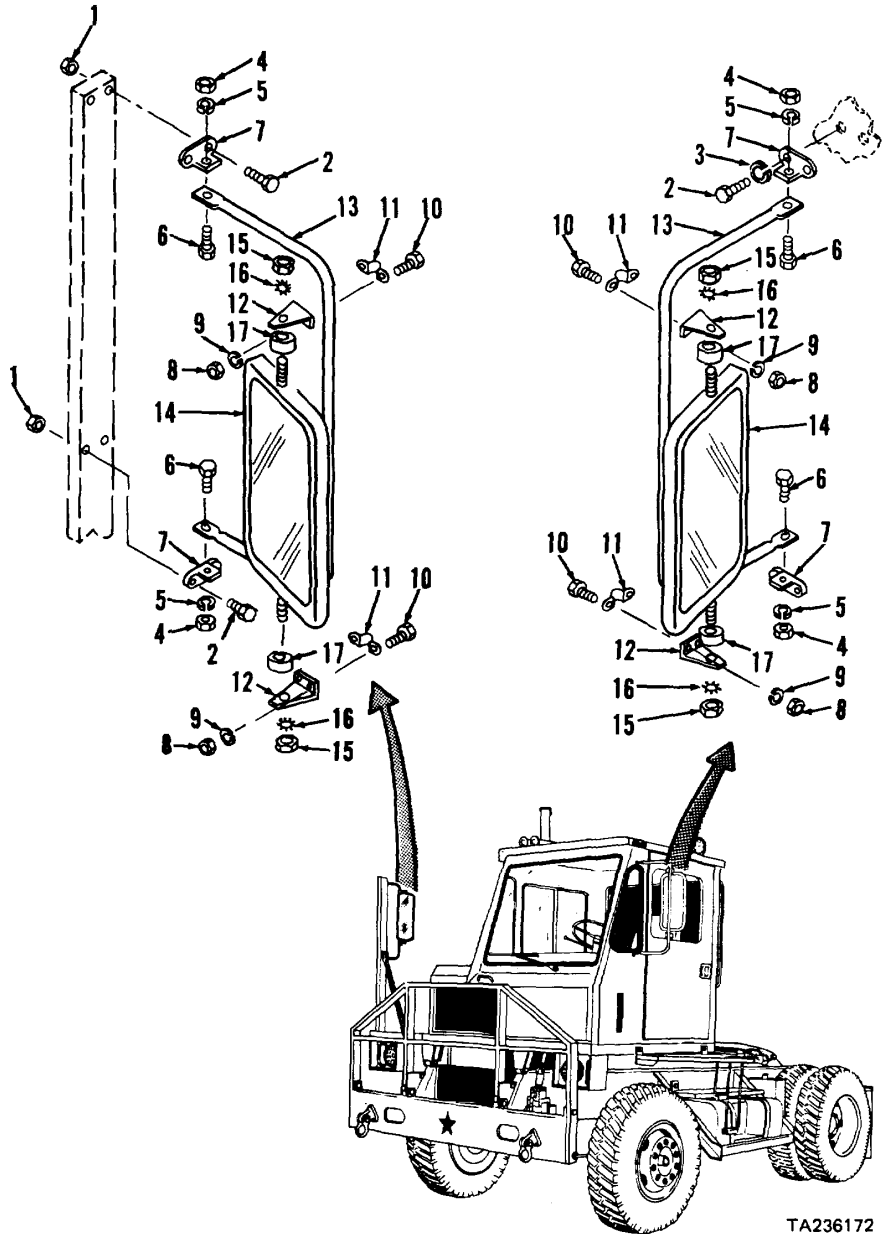

KEY

- 1. Locknuts (4)
- 2. Capscrews (8)
- 3. Lock washers (4)
- 4. Nuts (4)
- 5. Lock washers (4)
- 6. Capscrews (4)
- 7. Mounting brackets(4)
- 8. Nuts (8)
- 9. Lock washers (8)
- 10. Capscrews (8)
- 11. Brackets (4)
- 12. Mounting brackets (4)
- 13. Mounting tubes (2)
- 14. Mirrors (2)
- 15. Nuts (4)
- 16. Lock washers (4)
- 17. Spacers (4)

TA236172

2-70. REARVIEW MIRRORS MAINTENANCE (CONT)

a. Side Mirrors (cont).

STEP	LOCATION	ITEM	ACTION	REMARKS
DISASSEMBLY (cont)				
3 (cont)		d. Mounting tube (13) and two brackets (11)	Separate	From mounting brackets (12)
		e. Two nuts (15) lock washers (16) mounting brackets (12) and spacers (17)	Remove	From mirror (14)

NOTE

Repeat step 3 to disassemble right hand side mirror.

CLEANING

4		a. Mirror (14)	Clean	Use solution of clean water and detergent; rinse with clean clear water and dry with clean cloths
---	--	----------------	-------	---

WARNING

Dry cleaning solvent (P-D-680) used to clean parts is toxic and flammable. Wear protective goggles and gloves and use only in a well ventilated area. Avoid contact with skin eyes and clothes and don't breathe vapors. Do not use near open flame or excessive heat and don't smoke when using it. Failure to do so could cause serious injury. If you become dizzy while using cleaning solvent get fresh air and medical attention immediately. If contact with skin or clothes is made flush with large amounts of water. If contact with eyes is made wash eyes with water and seek medical aid immediately.

		b. All other parts	Clean	Use cleaning solvent P-D-680; dry with clean cloths
--	--	--------------------	-------	---

2-70. REARVIEW MIRRORS MAINTENANCE (CONT)

a. Side Mirrors (cont).

STEP	LOCATION	ITEM	ACTION	REMARKS
INSPECTION				
5		a. Brackets (7 11 and 12) and mounting tubes (13)	Inspect for: cracks breaks bent or dented condition	Replace if any defects are observed
		b. Mirror (14)	Inspect for: cracks chipping distortion	Replace if defects are observed
		c. All other parts	Inspect for: thread damage distortion deformation	Replace if defects are observed
REASSEMBLY				
6	Mirror left hand side	a. Two spacers (17) mount- ing brackets (12) lock washers (16) and nuts (15)	Install loosely	On mirror (14); do not tighten
		b. Mounting brack- ets (12) and brackets (11)	Position	On mounting tube (13)
		c. Four capscrews (10) lock washers (9) and nuts (8)	Install	
		d. Two mounting brackets (7)	Position	On ends of mounting tube (13)
		e. Two capscrews (6) lock washers (5) and nuts (4)	Install	

NOTE

Repeat step 6 to reassemble right hand side mirror.

2-70. REARVIEW MIRRORS MAINTENANCE (CONT)

- a. Side Mirrors (cont).

STEP	LOCATION	ITEM	ACTION	REMARKS
INSTALLATION				
7	Vehicle front left side	a. Mounting tube (13) and mirror (14)	Position	On cab
		b. Four capscrews (2) and lock washers (3)	Install and tighten	
8	Vehicle front right side	a. Mounting tube (13) and mirror (14)	Position	On mirror support
		b. Four capscrews (2) and lock-nuts (1)	Install and tighten	
9	Vehicle front	a. Two mirrors (14)	Adjust	To correct viewing position from cab
		b. Nuts (15)	Tighten	Secures adjustment

2-70. REARVIEW MIRRORS MAINTENANCE (CONT)

b. Inside Mirror.

This task covers:

- a. Removal
- b. Cleaning

- c. Inspection
- d. Installation

INITIAL SETUP

Tools

No. 1 Common Organizational Maintenance

Tool Kit

Socket wrench set 3/8 inch drive

Equipment Condition

Open end wrench set

Personnel Required

Wheel Vehicle Mechanic MOS 63B

Paragraph

Condition Description

Materials/Parts

Cleaning solvent

Item 1 Appendix C

Clean cloths

Item 2 Appendix C

Detergent

Item 27 Appendix C

Vehicle parked on level surface engine off and parking brake applied.

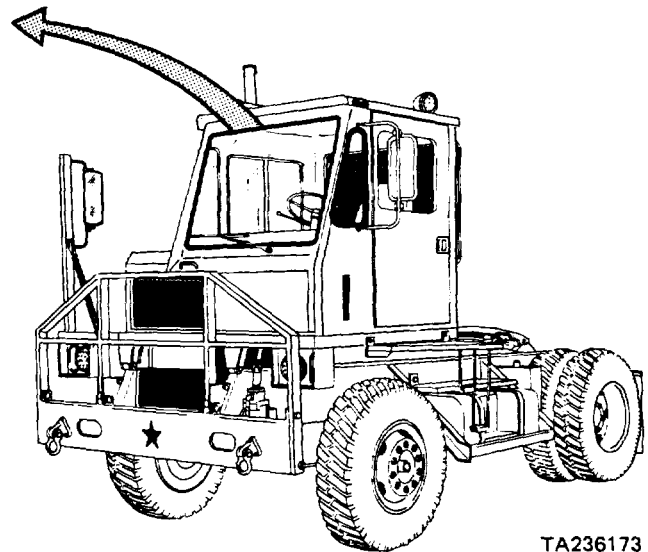
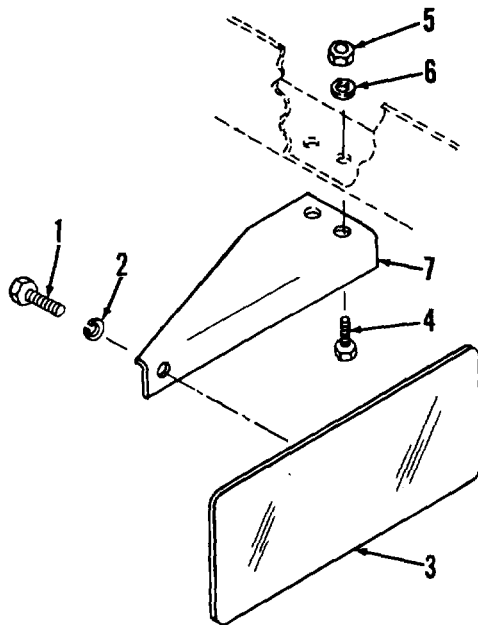

TA236173

KEY

- 1. Screw
- 2. Lock washer
- 3. Mirror
- 4. Capscrews (2)
- 5. Locknuts (2)
- 6. Washers (2)
- 7. Mirror bracket

2-70. REARVIEW MIRRORS MAINTENANCE (CONT)

b. Inside Mirror (cont).

STEP	LOCATION	ITEM	ACTION	REMARKS
REMOVAL				
1	Cab interior right side top	a. Screw (1) and lock washer (2)	Remove	Support mirror (3)
		b. Mirror (3)	Remove	Support mirror bracket (7)
		c. Two capscrews (4) lock-nuts (5) and washers (6)	Remove	
		d. Mirror bracket (7)	Remove	
CLEANING				
2		a. Mirror (3)	Clean	Use solution of clean warm water and detergent; rinse with clean water and dry using clean cloth
<u>WARNING</u>				
Dry cleaning solvent (P-D-680) used to clean parts is toxic and flammable. Wear protective goggles and gloves and use only in a well ventilated area. Avoid contact with skin eyes and clothes and don't breathe vapors. Do not use near open flame or excessive heat and don't smoke when using it. Failure to do so could cause serious injury. If you become dizzy while using cleaning solvent get fresh air and medical attention immediately. If contact with skin or clothes is made flush with large amounts of water. If contact with eyes is made wash eyes with water and seek medical aid immediately.				
		b. All other parts	Clean	Use cleaning solvent P-D-680; dry using clean cloths
INSPECTION				
3		a. Mirror (3)	Inspect for: cracks loose glass frame bent or damaged	Replace if defects observed

2-70. REARVIEW MIRRORS MAINTENANCE (CONT)

b. Inside Mirror (cont).

STEP	LOCATION	ITEM	ACTION	REMARKS
INSPECTION (cont)				
3 (cont)		b. Mirror bracket (7)	Inspect for: cracks dents bent condition	Replace if defects observed
		c. All other parts	Inspect for: thread damage distortion deformation	Replace if defects observed
INSTALLATION				
4	Cab interior right side top	a. Mirror bracket (7)	Position holes in cab	Align holes in bracket with
		b. Two capscrews (4) washers (6) and locknuts (5)	Install and tighten	
		c. Mirror (3)	Position	Insert mirror stud through hole in bracket (7)
		d. Lock washer (2) and screw (1)	Install and tighten	
		e. Mirror (3)	Adjust	

2-71. SUN VISOR WARNING TRIANGLE AND FIRST AID KIT MAINTENANCE

a. Sun Visor.

This task covers:

- a. Removal
- b. Disassembly
- c. Cleaning
- d. Inspection
- e. Reassembly
- f. Installation/Replacement

INITIAL SETUP

Tools

No. 1 Common Organizational Maintenance

Tool Kit

- Open end wrench adjustable
- Safety glasses

Personnel Required

Wheel Vehicle Mechanic MOS 63B

Equipment Condition

Paragraph Condition Description

Materials/Parts

- Cleaning solvent Item 1 Appendix C
- Clean cloths Item 2 Appendix C
- Detergent Item 27 Appendix C

Vehicle parked on level surface engine off and parking brake applied.

KEY

- 1. Capscrews (4)
- 2. Washers (4)
- 3. Washers (4)
- 4. Sun visor
- 5. Knobs (2)
- 6. Spacers (2)
- 7. Capscrews (2)
- 8. Brackets (2)
- 9. Washers (2)
- 10. Clamps (2)

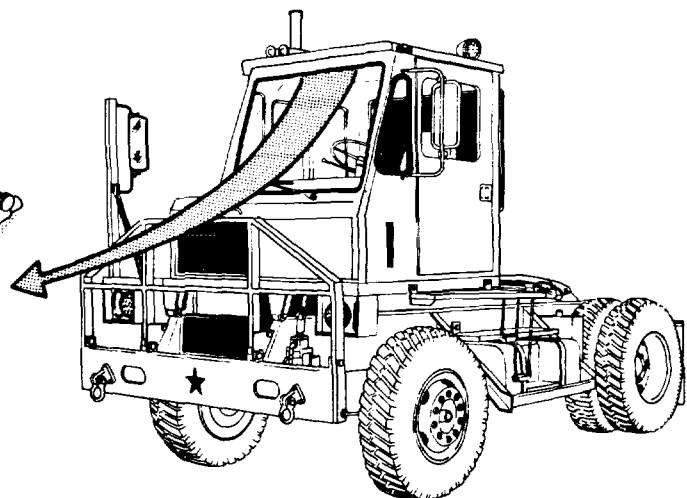
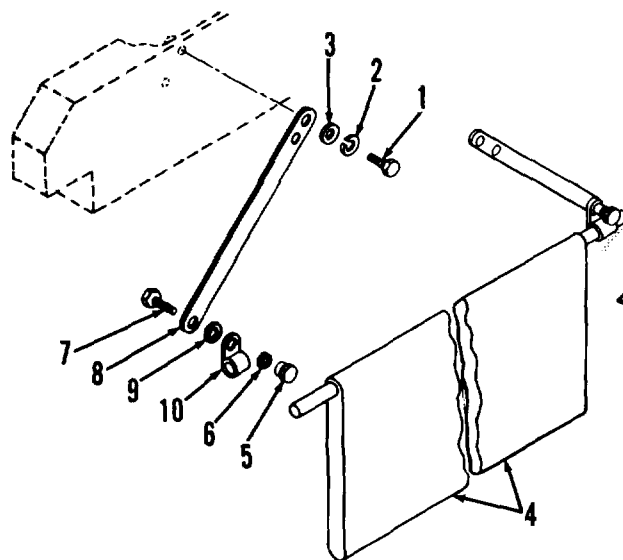

TA236099

2-71. SUN VISOR WARNING TRIANGLE AND FIRST AID KIT MAINTENANCE (CONT)

a. Sun Visor (cont).

STEP	LOCATION	ITEM	ACTION	REMARKS
REMOVAL				
1	Cab front above wind-shield	a. Two knobs (5) remove b. Sun visor (4) c. Four capscrews (1) and eight washers (2 and 3) d. Sun visor (4) assembly	Loosen Lower Remove Remove	Turn counterclockwise; do not Tilt down Support sun visor (4)

DISASSEMBLY

2	Sun visor (4)	a. Two knobs (5) and spacers (6) b. Two capscrews (7) brackets (8) and washers (9) c. Two clamps (10) (4)	Remove Remove Remove	Turn knobs counterclockwise Pull from ends of sun visor
---	---------------	---	----------------------------	--

CLEANING

3	a. Sun visor (4)	Clean	Use mild detergent solution
---	------------------	-------	-----------------------------

WARNING

Dry cleaning solvent (P-D-680) used to clean parts is toxic and flammable. Wear protective goggles and gloves and use only in a well ventilated area. Avoid contact with skin eyes and clothes and don't breathe vapors. Do not use near open flame or excessive heat and don't smoke when using it. Failure to do so could cause serious injury. If you become dizzy while using cleaning solvent get fresh air and medical attention immediately. If contact with skin or clothes is made flush with large amounts of water. If contact with eyes is made wash eyes with water and seek medical aid immediately.

b. All other parts	Clean	Use cleaning solvent P-D-680; dry with clean cloths
--------------------	-------	---

2-71. SUN VISOR WARNING TRIANGLE AND FIRST AID KIT MAINTENANCE (CONT)
--

a. Sun Visor (cont).

STEP	LOCATION	ITEM	ACTION	REMARKS
INSPECTION				
4		a. Sun visor (4)	Inspect	Replace if torn broken or damaged
		b. All other parts	Inspect	Replace if bent twisted or threads damaged
REASSEMBLY				
5	Sun visor (4)	a. Two clamps (10)	Position	On ends of sun visor (4)
		b. Two capscrews (7) brackets (8) and washers (9)	Position	On clamps (10)
		c. Two spacers (6) and knobs (5)	Install on capscrews	Turn knobs (5) clockwise until snug; do not tighten fully
INSTALLATION/REPLACEMENT				
6	Cab front above windshield	a. Sun visor (4) assembly	Position top of cab	Align brackets with holes at
		b. Four capscrews (1) and eight washers (2 and 3)	Install and tighten	
		c. Sun visor (4)	Adjust	To desired position; then turn knobs (5) clockwise to secure adjustment

2-71. SUN VISOR WARNING TRIANGLE AND FIRST AID KIT MAINTENANCE (CONT)

b. Warning Triangle.

This task covers:

- a. Removal
- b. Cleaning
- c. Inspection
- d. Installation

INITIAL SETUP

Tools

- No. 1 Common Organizational Maintenance Tool Kit
- Screwdriver
- Open end wrench adjustable
- Safety glasses

Personnel Required

Wheel Vehicle Mechanic MOS 63B

Equipment Condition

Paragraph Condition Description

Vehicle parked on level surface engine off and parking brake applied.

Materials/Parts

- Cleaning solvent Item 1 Appendix C
- Clean cloths Item 2 Appendix C
- Detergent Item 27 Appendix C

KEY

- 1. Box
- 2. Warning triangles (3)
- 3. Lock nuts (2)
- 4. Washers (2)
- 5. Capscrews (2)
- 6. Washers (2)
- 7. Mount

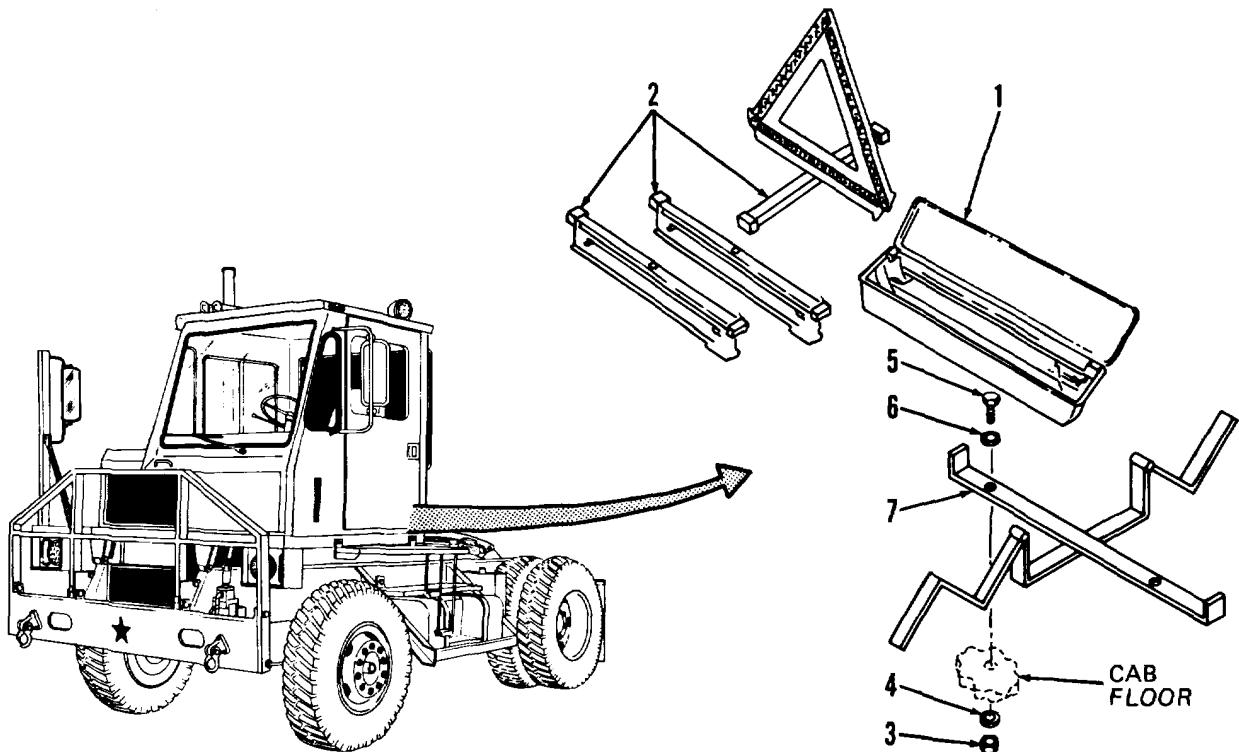

TA236131

2-71. SUN VISOR WARNING TRIANGLE AND FIRST AID KIT MAINTENANCE (CONT) |

b. Warning Triangle (cont).

STEP	LOCATION	ITEM	ACTION	REMARKS
REMOVAL				
1	Cab floor	a. Mount (7) b. Box (1) c. Three warning triangles (2) d. Two lock nuts (3) and washers (4) e. Two capscrews (5) and washers (6) f. Mount (7)	Unlatch a. Remove b. Open lid Remove Remove Remove Remove	Lift from mount (7) From box (1) From underside of cab floor
CLEANING				
2		a. Warning triangles (2)	Clean	Use mild detergent solution; dry using clean cloths

WARNING

Dry cleaning solvent (P-D-680) used to clean parts is toxic and flammable. Wear protective goggles and gloves and use only in a well ventilated area. Avoid contact with skin eyes and clothes and don't breathe vapors. Do not use near open flame or excessive heat and don't smoke when using it. Failure to do so could cause serious injury. If you become dizzy while using cleaning solvent get fresh air and medical attention immediately. If contact with skin or clothes is made flush with large amounts of water. If contact with eyes is made wash eyes with water and seek medical aid immediately.

Compressed air must not exceed 30 psi. Wear safety glasses when drying parts with compressed air. Failure to do so could cause serious injury to eyes and possible blindness. If you hurt your eyes or if a foreign object is blown into your eyes seek medical attention immediately.

b. All other parts	Clean	Use cleaning solvent P-D-680; dry using compressed air or clean cloths
--------------------	-------	--

2-71. SUN VISOR WARNING TRIANGLE AND FIRST AID KIT MAINTENANCE (CONT)
--

b. Warning Triangle (cont).

STEP	LOCATION	ITEM	ACTION	REMARKS
INSPECTION				
3		a. Box (1)	Inspect	Replace if dented or otherwise damaged
		b. Warning triangles (2)	Inspect	Replace if reflective surface crazed cracked or otherwise damaged
		c. All other parts	Inspect	Replace if cracked bent or threads damaged
INSTALLATION				
4	Cab floor	a. Mount (7)	Position	
		b. Two capscrews (5) and washers (6)	Install	
		c. Two washers (4) and lock nuts (3)	Install and tighten	Secures mount (7)
		d. Three warning triangles (2)	Install	Fold to closed position and place in box (1)
		e. Box (1)	a. Close lid b. Position	On mount (7)
		f. Mount (7)	Latch	Secures box (1)

2-803

2-71. SUN VISOR WARNING TRIANGLE AND FIRST AID KIT MAINTENANCE (CONT)

c. First Aid Kit.

This task covers:

- a. Removal
- b. Cleaning
- c. Inspection
- d. Installation

INITIAL SETUP

Tools

No. 1 Common Organizational Maintenance
Tool Kit
Screwdriver

Personnel Required

Wheel Vehicle Mechanic MOS 63B

Equipment Condition

Paragraph Condition Description

Materials/Parts

Cleaning solvent Item 1 Appendix C
Clean cloths Item 2 Appendix C

Vehicle parked on level surface engine off and parking brake applied.

KEY

- 1. Screws (2)
- 2. Washers (2)
- 3. First aid kit

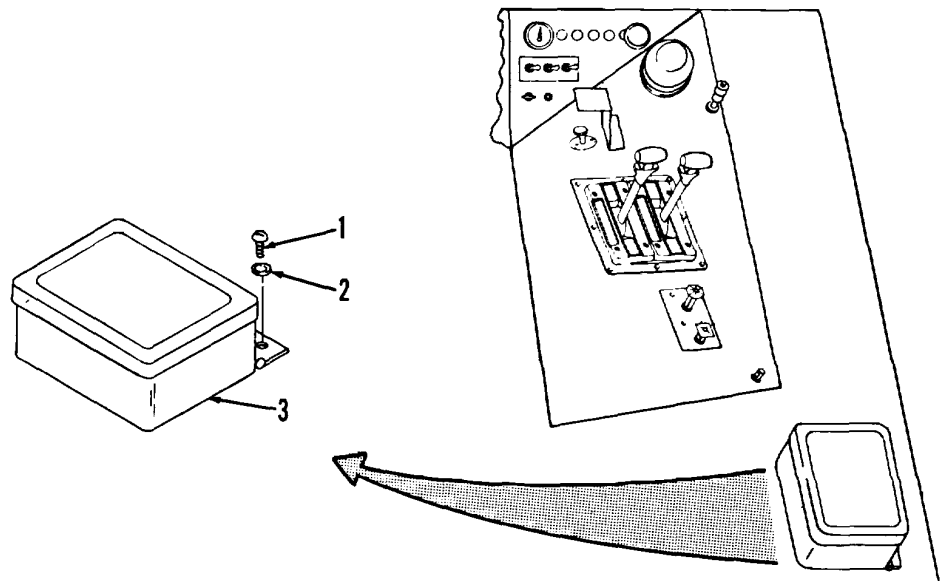

TA236216

STEP	LOCATION	ITEM	ACTION	REMARKS
REMOVAL				
1	Right cab panel	a. Two screws (1) and washers (2)	Remove	
		b. First aid kit (3)	Remove	

2-71. SUN VISOR WARNING TRIANGLE AND FIRST AID KIT MAINTENANCE (CONT)

c. First Aid Kit (cont).

STEP	LOCATION	ITEM	ACTION	REMARKS
CLEANING				
2		a. First aid kit (3)	Clean	Wipe exterior of box with clean damp cloth only

WARNING

Dry cleaning solvent (P-D-680) used to clean parts is toxic and flammable. Wear protective goggles and gloves and use only in a well ventilated area. Avoid contact with skin eyes and clothes and don't breathe vapors. Do not use near open flame or excessive heat and don't smoke when using it. Failure to do so could cause serious injury. If you become dizzy while using cleaning solvent get fresh air and medical attention immediately. If contact with skin or clothes is made flush with large amounts of water. If contact with eyes is made wash eyes with water and seek medical aid immediately.

		b. Screws (1) and washers (2)	Clean	Use cleaning solvent P-D-680; dry with clean cloths
--	--	-------------------------------	-------	---

INSPECTION

3		a. First aid kit (3)	a. Inspect box	Replace kit if box lid missing or box severely damaged
			b. Inventory contents	Check contents against list inside box. Replace any missing non-sterile or expended item
		b. Screws (1) and washers (2)	Inspect	Replace if cracked distorted or threads damaged

INSTALLATION

4	Right cab panel	a. First aid kit (3)	Position
		b. Two screws (1) and washers (2)	Install and tighten

2-72. AIR HORN MAINTENANCE

- This task covers:
- a. Removal
 - b. Disassembly
 - c. Cleaning
 - g. Adjustment
 - d. Inspection
 - e. Reassembly
 - f. Installation

INITIAL SETUP

Tools

No. 1 Common Organizational Maintenance

Tool Kit

- Screwdriver
- Socket wrench set
- Open end wrench set
- Safety glasses

Diaphragms

FSCM 06853 PN 212685

Adhesive

FSCM 04963 PN 4500

Personnel Required

Wheel Vehicle Mechanic MOS 63B

Equipment Condition

Paragraph

Condition Description

Materials/Parts

Cleaning

- solvent Item 1 Appendix C
- Clean cloths Item 2 Appendix C
- Detergent Item 27 Appendix C
- Teflon tape Item 43 Appendix C
- Two tie straps FSCM 96906 PN MS3667-1-9
- Gasket FSCM 06853 PN 231435

Vehicle parked on level surface engine off and parking brake applied. Right side window open. All air pressure relieved.

2-41h(1)

STEP	LOCATION	ITEM	ACTION	REMARKS
------	----------	------	--------	---------

REMOVAL

1	Cab roof	a. Elbow (7)	Loosen nut	
		b. Tubing (1)	Disconnect	From elbow (7)
		c. Screw (2) washer (3) and chain (4)	Remove	From cab roof
		d. Chain (4) and S-hook (5)	Remove	From valve (8) lever
		e. Elbow (6) with valve (8)	Remove	From nipple (9)
		f. Elbows (6 and 7)	Remove	From valve (8)
		g. Nipple (9)	Remove	
		h. Nut (10) lock washer (11) and washer (12)	Remove	

CAUTION

Head liner is glued in place. Do not tear or rip headliner in following step.

2-72. AIR HORN MAINTENANCE (CONT)

KEY

1. Tubing
2. Screw
3. Washer
4. Chain
5. S-hook
6. Elbow
7. Elbow
8. Valve
9. Nipple
10. Nut
11. Lock washer
12. Washer
13. Nut
14. Lock washer
15. Capscrew
16. Gasket
17. Elbow
18. Tie straps (2)
19. Locknuts (2)
20. Washers (2)
21. Clamps (2)
22. Long bell
23. Short bell
24. Screens (2)
25. Locknuts (2)
26. Seat assemblies (2)
27. Screws (8)
28. Lock washers (8)
29. Covers (2)
30. Contacts (2)
31. Springs (2)
32. Diaphragms (2)
33. Coupling
34. Body

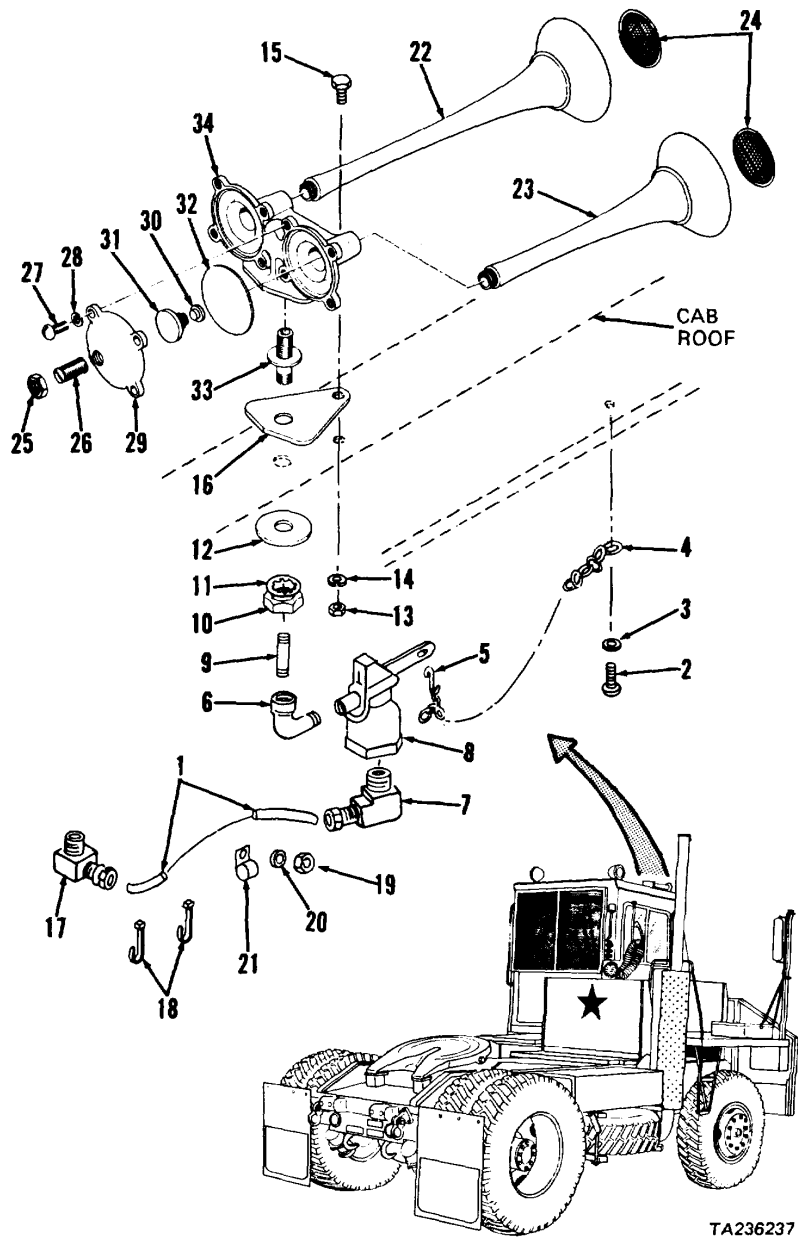

TA236237

2-72. AIR HORN MAINTENANCE (CONT)

STEP	LOCATION	ITEM	ACTION	REMARKS
REMOVAL (cont)				
1 (cont)		i. Head liner	Peel back carefully	Just enough to gain access to nut (13) and lock washer (14)
		j. Nut (13) lock washer (14) and capscrew (15)	Remove	
		k. Air horn assembly (22 thru 34)	Remove	Lift from cab roof
		l. Gasket (16)	Remove	Discard gasket (16)
2	Cab tilt pump	Cab	Tilt 45 degrees	
3	Cab under-side air control valve	a. Elbow (17)	Loosen nut	From elbow (17) From tee in air control valve port
		b. Tubing (1)	Disconnect	
		c. Elbow (17)	Remove	

NOTE

Perform steps 3d thru 3f below only if inspection indicates need for replacement of tubing (1).

		d. Two tie straps (18)	Cut and remove	Discard tie straps (18)
		e. Two locknuts (19) washers (20) and clamps (21)	Remove	
		f. Tubing (1)	a. Cut end off b. Remove	To remove tubing nut from elbow (7)
DISASSEMBLY				
4	Body (34)	a. Bells (22 and 23)	Remove	Turn counterclockwise
		b. Two screens (24)	Remove	Pry from bells (22 and 23)

2-72. AIR HORN MAINTENANCE (CONT)

STEP	LOCATION	ITEM	ACTION	REMARKS
DISASSEMBLY (cont)				
4 (cont)			NOTE	
			Disassemble the following horn parts only if necessary for replacement.	
		c. Two locknuts (25) and seat assemblies (26)	Remove	
		d. Eight screws (27) and lock washers (28)	Remove	
		e. Two covers (29)	Separate	From body (34)
		f. Two contacts (30) and springs (31)	Remove	From covers (29)
		g. Two diaphragms (32)	Remove	From body (34)
		h. Coupling (33)	Remove	Turn counterclockwise

CLEANING

5		a. Tubing (1) and diaphragms (32)	Clean	Wipe with clean cloth moistened with detergent solution
---	--	-----------------------------------	-------	---

WARNING

Dry cleaning solvent (P-D-680) used to clean parts is toxic and flammable. Wear protective goggles and gloves and use only in a well ventilated area. Avoid contact with skin eyes and clothes and don't breathe vapors. Do not use near open flame or excessive heat and don't smoke when using it. Failure to do so could cause serious injury. If you become dizzy while using cleaning solvent get fresh air and medical attention immediately. If contact with skin or clothes is made flush with large amounts of water. If contact with eyes is made wash eyes with water and seek medical aid immediately.

Compressed air must not exceed 30 psi. Wear safety glasses when drying parts with compressed air. Failure to do so could cause serious injury to eyes and possible blindness. If you hurt your eyes or if a foreign object is blown into your eyes seek medical attention immediately.

2-72. AIR HORN MAINTENANCE (CONT)

STEP	LOCATION	ITEM	ACTION	REMARKS
CLEANING (cont)				
5 (cont)		b. Valve (8)	Clean	Wipe exterior only with clean cloth moistened with cleaning solvent P-D-680; dry with compressed air
		c. Screens (24) and all other parts	Clean	Use cleaning solvent P-D-680; dry using compressed air or clean cloths
INSPECTION				
6		a. Tubing (1)	Inspect	Replace if cracked twisted split or kinked
		b. Springs (31)	Inspect	Replace if cracked broken or permanently set
		c. Covers (29) and body (34)	Inspect	Replace if cracked or if diaphragm seat is chipped or otherwise damaged
		d. Diaphragms (32)	Inspect	Replace if cracked distorted or deteriorated
		e. All other parts	Inspect	Replace if cracked bent broken excessively worn or threads damaged
REASSEMBLY				
7	Body (34)	a. Coupling (33)	Install	Wrap threads at long end with Teflon tape; turn clockwise to tighten
		b. Two diaphragms (32)	Position	In body (34)
		c. Two springs (31) and contacts (30)	Position	In covers (29)
		d. Two covers (29)	Position	On body with mounting holes aligned
		e. Eight screws (27) and lock washers (28)	Install	Tighten screws (27) evenly
		f. Two seat assemblies (26)	Install	Turn clockwise
		g. Two locknuts (25)	Install	Do not tighten
		h. Two screens (24)	Install	Press into bells (22 and 23)
		i. Bells (22 and 23)	Install	Turn clockwise

2-72. AIR HORN MAINTENANCE (CONT)

STEP	LOCATION	ITEM	ACTION	REMARKS
INSTALLATION				
NOTE				
Wrap threads of male fittings with Teflon tape before installation to prevent leakage.				
8	Cab under-side air control valve	a. Tubing (1) b. Elbow (17) c. Tubing (1) d. Two clamps (21) washers (20) and locknuts (19) e. Two new tie straps (18)	Route Install Connect nut Install Install	If removed from tractor In tee at air control valve To elbow (17); tighten elbow nut
9	Cab tilt pump	Cab	Lower	To normal operating position
10	Cab roof	a. Air horn assembly (22 thru 34) with new gasket (16) b. Capscrew (15) lock washer (14) and nut (13) c. Head liner d. Washer (12) lock washer (11) and nut (10) e. Nipple (9) f. Elbows (6 and 7) g. Elbow (6) with valve (8) h. Tubing (1) i. Chain (4) washer (3) and screw (2) j. Chain (4) and S-hook (5)	Position Install Install Install and tighten Install Install Install Connect Install Connect	Reattach peeled head liner to cab ceiling using adhesive In valve (8) On nipple (9) To elbow (7); tighten elbow nut In cab ceiling To valve (8) lever

2-72. AIR HORN MAINTENANCE (CONT)
--

STEP	LOCATION	ITEM	ACTION	REMARKS
------	----------	------	--------	---------

INSTALLATION (cont)

11	Tractor	Air pressure	Restore	Para 2-41h(l)
----	---------	--------------	---------	---------------

ADJUSTMENT

12	Cab roof	a. Two locknuts (25) b. Air horn c. Two seat assemblies (26)	Loosen if necessary Sound Adjust loudest sound	Pull chain (4) down Turn with screwdriver for
----	----------	--	---	--

NOTE

Use screwdriver to prevent seat assemblies (26) from turning while performing following step.

		d. Two locknuts (25)	Tighten	Secures adjustment
--	--	----------------------	---------	--------------------

2-812

2-73. HEATERS MAINTENANCE

a. Cab Heater Hoses and Temperature Valve.

- This task covers:
- a. Removal
 - b. Cleaning
 - c. Inspection
 - d. Installation

INITIAL SETUP

Tools

- No. 1 Common Organizational Maintenance
- Tool Kit
- Screwdriver
- Socket wrench set
- Hose clamp pliers
- Safety glasses
- No. 2 Common Organizational Maintenance
- Tool Kit
- Two C-clamps
- Four wood blocks
- Container

- Detergent
- Two tie straps
- Tie strap
- Item 27 Appendix C
- FSCM 96906 PN MS3667-1-9
- FSCM 96906 PN MS3667-2-9

Personnel Required

Two Wheel Vehicle Mechanics MOS 63B

Equipment Condition

Paragraph	Condition Description
	Vehicle parked on level surface engine off and parking brake applied. Radiator and engine cool. Temperature control pulled out fully to open temperature valve.

Materials/Parts

- Cleaning solvent
- Clean cloths
- Tags
- Item 1 Appendix C
- Item 2 Appendix C
- Item 14 Appendix C

STEP	LOCATION	ITEM	ACTION	REMARKS
------	----------	------	--------	---------

REMOVAL

NOTE

Tag and identify hoses before disconnecting and removing.

1	Tractor cab underside	a. Hoses (2 and 3)	a. Tag	Use wood blocks and C-clamps Under hoses (2 and 3)
		b. Suitable container	b. Clamp Position	
		c. Two clamps (1)	Loosen	
		d. Hoses (2 and 3)	Disconnect	
		e. Two clamps (1)	Remove	
2	Tractor cab inside	a. Instrument panel	Raise	Para 2-26g(1)
		b. Two clamps (4)	Loosen	Use hose clamp pliers; slide hoses away from heater (27)
		c. Defroster hoses (12 and 13)	Disconnect	From heater (27)

2-73. HEATERS MAINTENANCE (CONT)

a. Cab Heater Hoses and Temperature Valve (cont).

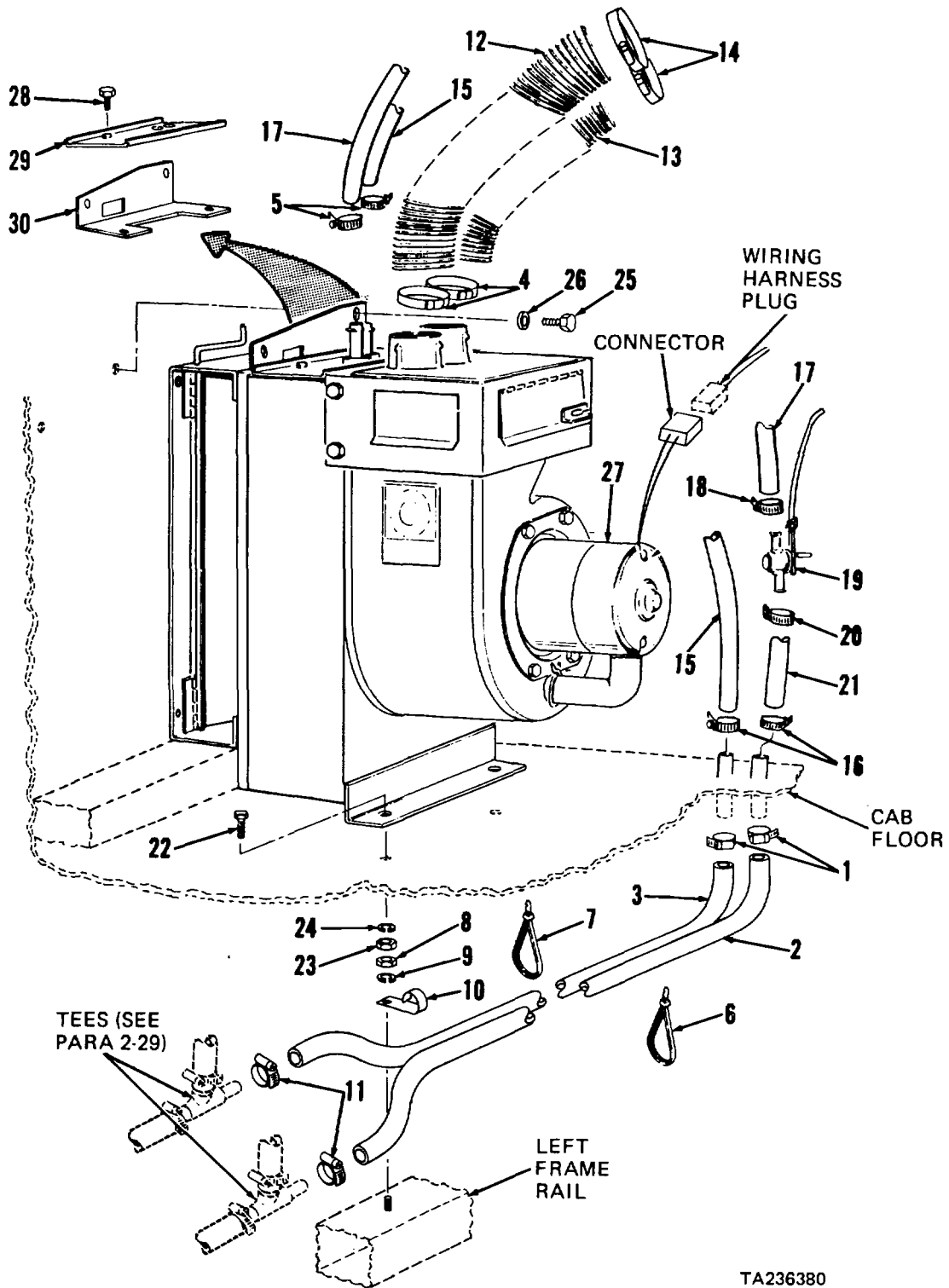

TA236380

2-73. HEATERS MAINTENANCE (CONT) I

a. Cab Heater Hoses and Temperature Valve (cont).

KEY

- | | | |
|-------------------|------------------------------|----------------------|
| 1. Clamps (2) | 11. Clamps (2) | 21. Hose (5") |
| 2. Hose | 12. Defroster hose (22-1/2") | 22. Capscrews (2) |
| 3. Hose | 13. Defroster hose (12") | 23. Nuts (2) |
| 4. Clamps (2) | 14. Clamps (2) | 24. Lock washers (2) |
| 5. Clamps (2) | 15. Hose (28") | 25. Capscrews (2) |
| 6. Tie strap | 16. Clamps (2) | 26. Washers (2) |
| 7. Tie straps (2) | 17. Hose (21") | 27. Heater |
| 8. Nut | 18. Clamp | 28. Capscrews (2) |
| 9. Lock washer | 19. Temperature valve | 29. Seal plate |
| 10. Clamps (2) | 20. Clamp | 30. Bracket |

STEP	LOCATION	ITEM	ACTION	REMARKS
------	----------	------	--------	---------

REMOVAL (cont)

2 (cont)		d. Two clamps (4)	Remove	Use hose clamp pliers
		e. Two clamps (5)	Loosen	
		f. Hoses (15 and 17)	a. Tag b. Disconnect	
		g. Two clamps (5)	Remove	

NOTE

If inspection indicates need for replacement of hoses or temperature valve proceed to step 3 below. Otherwise proceed directly to step 9 below to remove heater.

3	Cab tilt pump	Cab	Tilt 45 degrees	
4	Radiator bottom	Radiator	Drain	Para 2-15a(1)
5	Tractor cab underside	a. Tie straps (6 and 7) b. C-clamps and wood blocks	Cut remove and discard Remove	Note locations for installation From hoses (2 and 3)
6	Left frame rail	a. Nut (8) lock washer (9) and two clamps (10) b. Two clamps (11)	Remove Loosen	

2-73. HEATERS MAINTENANCE (CONT)

a. Cab Heater Hoses and Temperature Valve (cont).

STEP	LOCATION	ITEM	ACTION	REMARKS
REMOVAL (cont)				
6 (cont)		c. Hoses (2 and 3) b. Disconnect d. Two clamps (11)	a. Tag Pull from tees Remove	
7	Cab tilt pump	Cab	Lower	To normal operating position
8	Tractor cab inside	a. Two clamps (14) b. Defroster hoses (12 and 13) c. Two clamps (14) d. Two clamps (16) e. Hose (15) d. Remove f. Hose (21) g. Two clamps (16) h. Clamp (18) i. Hose (17) j. Clamp (18) k. Clamp (20) l. Hose (21) m. Clamp (20) n. Temperature control o. Floor mat	Loosen Disconnect Remove Loosen a. Tag From cab Disconnect Remove Loosen Disconnect Remove Loosen Remove Remove Disconnect from valve (19) Move	Use hose clamp pliers; slide clamps on defroster hoses Remove from cab Use hose clamp pliers Pull from cab floor port From hoses (15 and 21) Pull from temperature valve (19) Pull from temperature valve (19) If necessary to replace temperature valve (19); para 2-73b Pull back from heater
9	Heater	a. Two capscrews (27) nuts (23) (23) and lock washers (24) b. Two capscrews (25) and washers (26) c. Connector d. Heater (27) e. Defroster and fresh air controls	Remove (22) nuts Remove Disconnect Move Disconnect	Position assistant under cab floor to prevent from turning Pull from wiring harness plug Slide on cab floor to gain access to control cables From heater (27); para 2-73b

2-73. HEATERS MAINTENANCE (CONT)

a. Cab Heater, Hoses, and Temperature Valve (cont).

STEP	LOCATION	ITEM	ACTION	REMARKS
REMOVAL (cont)				
9 (cont)		f. Two capscrews (28), seal plate (29), and bracket (30)	Remove	
		g. Heater (27)	Remove	From cab
CLEANING				
10		a. All hoses	Clean	Use clean cloth and mild detergent solution
		b. Heater (27)	a. Clean	Wipe exterior of motor with clean, dry cloth. Clean remainder of exterior with clean cloth and mild detergent solution
			b. Flush	Connect water supply to hose ports and flush core; then reverse connection and flush in opposite direction until water is clear

WARNING

Dry cleaning solvent (P-D-680), used to clean parts is toxic and flammable. Wear protective goggles and gloves and use only in a well ventilated area. Avoid contact with skin, eyes, and clothes and don't breathe vapors. Do not use near open flame or excessive heat and don't smoke when using it. Failure to do so could cause serious injury. If you become dizzy while using cleaning solvent, get fresh air and medical attention immediately. If contact with skin or clothes is made, flush with large amounts of water. If contact with eyes is made, wash eyes with water and seek medical aid immediately.

c. All other parts Clean Use cleaning solvent P-D-680; dry with clean cloths

2-73. HEATERS MAINTENANCE (CONT)

- a. Cab Heater, Hoses, and Temperature Valve (cont).

STEP	LOCATION	ITEM	ACTION	REMARKS
INSPECTION				
11		a. All hoses	Inspect	Replace if cracked, frayed, split, or deteriorated
		b. All clamps	Inspect	Replace if cracked, worn, or broken
		c. Heater (27)	Inspect	Repair if defective (notify direct support maintenance)
		d. All other parts	Inspect	Replace if cracked, broken, or threads damaged
INSTALLATION				
12	Heater (27)	a. Heater (27)	Position	On cab floor
		b. Bracket (30), plate (29), and two cap-screws (28)	Install	
		c. Fresh air and defroster controls	Connect	To heater (27); para 2-73b
		d. Two washers (26) and cap-screws (25)	Install and tighten	
		e. Two capscrews (22), lock washers (24), and nuts (23)	Install and tighten	Position assistant under cab floor to prevent nuts (23) from turning
		f. Connector	Connect	Push onto wiring harness plug
NOTE				
If hoses were removed, proceed to step 13 below. Otherwise, proceed directly to step 17 below.				
13	Tractor cab, inside	a. Two clamps (16)	Position	On hoses (15 and 21)
		b. Hoses (15 and 21)	Connect	To cab floor ports, as tagged
		c. Two clamps (16)	Tighten	
		d. Clamp (20)	Position	On hose (21)
		e. Temperature valve (19)	Install	In hose (21), with clamp for control cable at top
		f. Clamp (20)	Tighten	
		g. Clamp (18)	Position	On hose (17)
		h. Hose (17)	Connect	To temperature valve (19)
		i. Clamp (18)	Tighten	

2-73. HEATERS MAINTENANCE (CONT)

a. Cab Heater, Hoses, and Temperature Valve (cont).

STEP	LOCATION	ITEM	ACTION	REMARKS
INSTALLATION (cont)				
13 (cont)		j. Temperature control	Connect	To temperature valve (19); para 2-73b
		k. Two clamps (14)	Position	On defroster hoses (12 and 13) using hose clamp pliers
		l. Defroster hoses (12 and 13)	Connect	To cab defroster ports
		m. Two clamps (14)	Tighten	Use hose clamp pliers
14	Cab tilt pump	Cab		Tilt 45 degrees
15	Left frame rail	a. Two clamps (11)	Position	On hoses (2 and 3) Push onto tees, as tagged
		b. Hoses (2 and 3)	Connect	
		c. Two clamps (11)	Tighten	Tighten nut (8)
		d. Two clamps (10)	Position	
		e. Lock washer (9) and nut (8)	Install	
		f. New tie straps (6 and 7)	Install	
16	Cab tilt pump	Cab	Lower	To normal operating position
17	Tractor cab, inside	a. Two clamps (5)	Position	On hoses (15 and 17) To heater (27), as tagged
		b. Hoses (15 and 17)	Connect	
		c. Two clamps (5)	Tighten	On defroster hoses (12 and 13) using hose clamp pliers To heater (27)
		d. Two clamps (4)	Position	
		e. Defroster hoses (12 and 13)	Connect	
		f. Two clamps (4)	Tighten	Use hose clamp pliers
		g. Instrument panel	Lower and secure	Para 2-26g(1)
18	Tractor cab, underside	a. Two clamps (1)	Position	On hoses (2 and 3) To cab floor ports
		b. Hoses (2 and 3)	Connect	
		c. Two clamps (1)	Tighten	If installed
		d. C-clamps and wood blocks	Remove	
19	Tractor, front	a. Radiator	Fill	Para 2-15a(1)
		b. Coolant over-flow tank	Check and fill	Para 2-15a(1)

2-73. HEATERS MAINTENANCE (CONT)

b. Defroster Control, Heater Temperature Control, and Fresh Air Control.

This task covers:

- a. Removal
- b. Cleaning
- c. Inspection
- f. Installation/Adjustment

INITIAL SETUP:

<u>Tools</u>	<u>Personnel Required</u>		
No. 1 Common Organizational Maintenance Tool Kit		Wheel Vehicle Mechanic MOS 63B	
Screwdriver		<u>Equipment Condition</u>	
Combination wrench set		Paragraph	Condition Description
Safety glasses			
<u>Materials/Parts</u>			
Cleaning solvent	Item 1, Appendix C		Parked on level surface, engine off, and parking brake applied.
Clean cloths	Item 2, Appendix C	2-34a	Battery ground cable disconnected.
Tags	Item 14, Appendix C		Instrument panel raised.
Detergent	Item 27, Appendix C	2-26g(1)	

STEP	LOCATION	ITEM	ACTION	REMARKS
------	----------	------	--------	---------

REMOVAL

1	Instrument panel, top	a. Three knobs (1) b. Nut (2)	Remove Remove	Rotate counterclockwise
---	-----------------------	----------------------------------	------------------	-------------------------

NOTE

Tag and identify all cables before disconnecting and removing.

2	Instrument panel, underside	a. Three cables (7, 10, and 13) b. Cable (13) c. Nut (3) d. Two locknuts (4)	Tag Lower Remove Loosen	From panel (17) From free end of cable (13) Slide down on cables (7 and 10)
3	Temperature valve	a. Screw (5) and clip (6) b. Cable (7) c. Locknut (4)	Remove Disconnect Remove	Pull from temperature valve lever From free end of cable (7)

2-73. HEATERS MAINTENANCE (CONT)

b. Defroster Control, Heater Temperature Control, and Fresh Air Control (cont).

KEY

- 1. Knobs (3)
- 2. Nut
- 3. Nut
- 4. Locknuts (2)
- 5. Screw
- 6. Clip
- 7. Temperature control cable
- 8. Screw
- 9. Clip
- 10. Fresh air control cable
- 11. Screws (2)
- 12. Clips (2)
- 13. Defroster control cable
- 14. Screw
- 15. Bracket
- 16. Screw
- 17. Panel
- 18. Nut

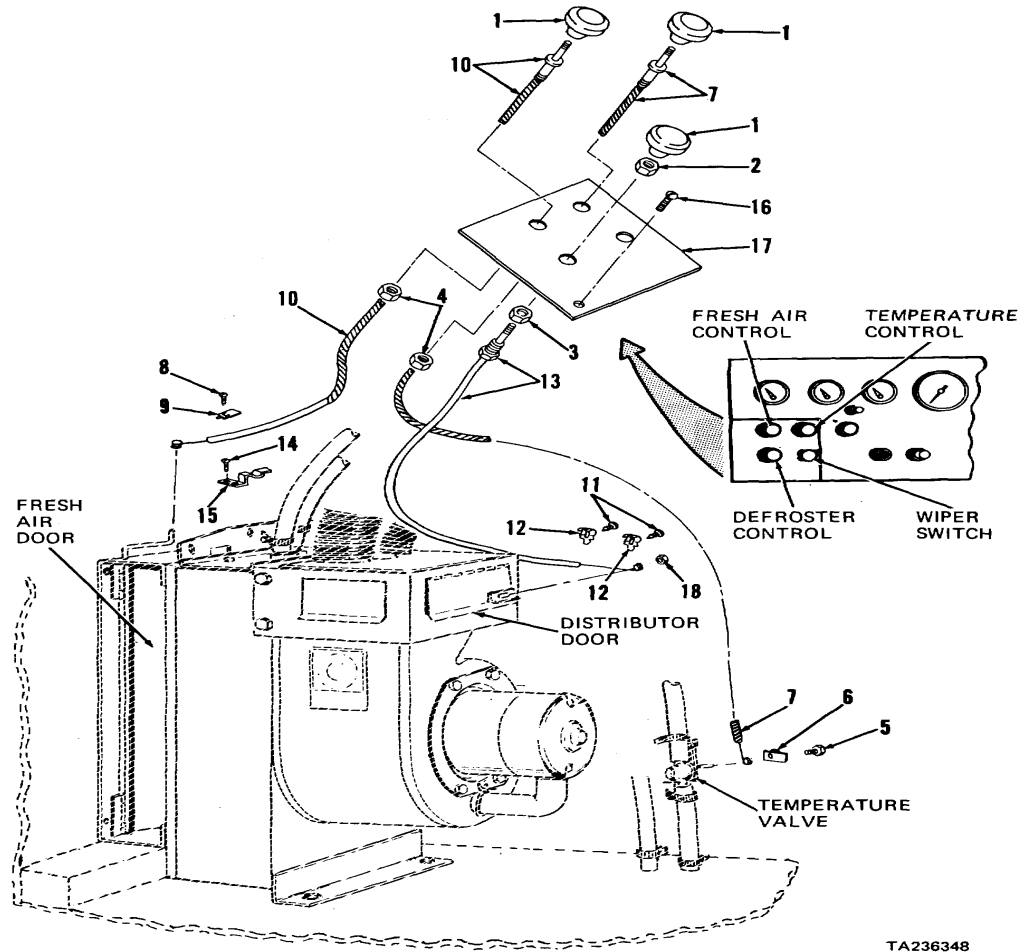

TA236348

2-73. HEATERS MAINTENANCE (CONT)

b. Defroster Control, Heater Temperature Control, and Fresh Air Control (cont).

STEP	LOCATION	ITEM	ACTION	REMARKS
REMOVAL (cont)				
4	Heater	a. Screw (8) and clip (9)	Remove	
		b. Cable (10)	Disconnect	Pull from fresh air door bellcrank
		c. Locknut (4)	Remove	From free end of cable (10)
NOTE				
Do not remove heater from cab in following step unless necessary for replacement. Remove heater attaching hardware and slide heater on cab floor with hoses attached to gain access to cable hardware.				
		d. Heater	Move	Remove attaching hardware (para 2-73a) and slide heater on cab floor
		e. Two screws (11) and clips (12)	Remove	
		f. Nut (18)	Remove	
		g. Cable (13)	Disconnect	Pull from distributor door lever
		h. Screw (14) and bracket (15)	Remove	If necessary for replacement
5	Instrument panel, top	a. Two cables (7 and 10)	Remove	Pull from top of panel (17)
NOTE				
Perform following steps only if necessary to remove panel (17).				
		b. Screw (16)	Remove	
		c. Wiper switch	Remove	Para 2-69b(1)
		d. Panel (17)	Remove	
CLEANING				
6		a. Knobs (1) and panel (17)	Clean	Use clean cloth and mild detergent solution

2-73. HEATERS MAINTENANCE (CONT)

b. Defroster Control, Heater Temperature Control, and Fresh Air Control (cont).

STEP	LOCATION	ITEM	ACTION	REMARKS
CLEANING (cont)				
<u>WARNING</u>				
6 (cont)		<p>Dry cleaning solvent (P-D-680), used to clean parts is toxic and flammable. Wear protective goggles and gloves and use only in a well ventilated area. Avoid contact with skin, eyes, and clothes and don't breathe vapors. Do not use near open flame or excessive heat and don't smoke when using it. Failure to do so could cause serious injury. If you become dizzy while using cleaning solvent, get fresh air and medical attention immediately. If contact with skin or clothes is made, flush with large amounts of water. If contact with eyes is made, wash eyes with water and seek medical aid immediately.</p> <p>Compressed air must not exceed 30 psi. Wear safety glasses when drying parts with compressed air. Failure to do so could cause serious injury to eyes and possible blindness. If you hurt your eyes or if a foreign object is blown into your eyes, seek medical attention immediately.</p>		
		b. All other parts	Clean	Use cleaning solvent P-D-680; dry with compressed air
INSPECTION				
7		a. Cables (7, 10, and 13)	Inspect	Replace if cracked, frayed, kinked, or threads damaged
		b. All other parts	Inspect	Replace if cracked, broken, or threads damaged
INSTALLATION/ADJUSTMENT				
8	Instrument panel, top	a. Plate (17)	Position	On instrument panel, if removed
		b. Wiper switch	Install	Para 2-69b(l)
		c. Screw (16)	Install and tighten	
		d. Two cables (7 and 10)	Install	Push through top of panel (17)
9	Heater	a. Bracket (15)	Position	
		b. Screw (14)	Install and tighten	Secures bracket (15)
		c. Two locknuts (4)	Position	Slide onto free ends of cables (7 and 10)
		d. Cable (13)	Route and install	Push wire end of cable (13) onto distributor door lever

2-73. HEATERS MAINTENANCE (CONT)

b. Defroster Control, Heater Temperature Control, and Fresh Air Control (cont).

STEP	LOCATION	ITEM	ACTION	REMARKS
INSTALLATION/ADJUSTMENT (cont)				
9 (cont)		e. Nut (18) f. Two clips (12) g. Two screws (11) h. Cable (13)	Install Position Install Adjust	Over cable (13) jacket Do not tighten Push knob end of cable (13) in fully while holding distributor door closed
		i. Two screws (11) j. Cable (10)	Tighten Route and install	Secures adjustment Push wire end of cable (10) onto fresh air door bellcrank
		k. Clip (9) l. Screw (8) m. Cable (10)	Position Install Adjust	Over cable (10) jacket Do not tighten Push knob end of cable (10) in fully while holding fresh air door closed
		n. Screw (8) o. Heater	Tighten Install and secure	Secures adjustment Para 2-73a
10	Instrument panel, underside	a. Two locknuts (4) b. Nut (3) c. Cable (13)	Install Install and position Position	Slide up to panel (17) and tighten to secure cables (7 and 10) On free end of cable (13) Install free end of cable (13) from bottom of panel (17)
11	Instrument panel, top	d. Tags a. Nut (2)	Remove Install and tighten	From cables (7, 10, and 13) Secures cable (13)
12	Temperature valve	b. Three knobs (1) a. Cable (7) b. Clip (6) c. Screw (5) d. Cable (7)	Install Route and install Position Install Adjust	Rotate clockwise Push wire end of cable (7) onto temperature valve lever Over cable (7) jacket Do not tighten Push knob end of cable (7) in fully while holding temper- ature valve lever closed
13	Battery box	e. Screw (5) Battery ground cable	Tighten Connect	Secures adjustment Para 2-34a

2-73. HEATERS MAINTENANCE (CONT)

- c. Battery Warmers.

This task covers:

- a. Removal
- b. Cleaning
- c. Inspection
- f. Installation/Adjustment

INITIAL SETUP:

Tools

No. 1 Common Organizational Maintenance Tool Kit

- Slip joint pliers
- Tool kit, electrical connector
- Wire stripper

Equipment Condition

Paragraph Condition Description

Materials/Parts

Clean cloths	Item 2, Appendix C	2-34b
Detergent	Item 27, Appendix C	
Electrical tape	Item 37, Appendix C	2-34a
10 tie straps	FSCM 96906 PN MS3667-2-9	

Personnel Required

Wheel Vehicle Mechanic MOS 63B

2-63c

Vehicle parked on level surface, engine off, and parking brake applied. Winterization system cable disconnected from junction box. Battery box lid raised and supported. Battery ground cable and positive cable disconnected; negative and positive lugs removed (wires and cables still attached); hold-down brackets removed. Spare tire mount lowered.

STEP	LOCATION	ITEM	ACTION	REMARKS
------	----------	------	--------	---------

REMOVAL

WARNING

Battery warmers operate from 110 Vac commercial power source. Disconnect winterization system cable from receptacle at front bumper of tractor before proceeding. Serious injury or death can result from contact with energized 110 Vac power lines.

Battery box lid is heavy. Secure lid in open position to prevent injury from falling lid. If you are injured, seek medical aid immediately.

1	Right hand frame rail, behind battery box	a. Electrical tape	Remove	From plastic tubing (2 and 3) Discard tie straps (1) Pull open at slits and remove from wire nuts (4), 3-wire cords (6 and 7), and battery end of 3-wire cord (5) From wire nuts (4)
		b. Four tie straps (1)	Cut and remove	
		c. Plastic tubing (2 and 3)	Remove	
		d. Electrical tape	Remove	
		e. Three wire nuts (4)	Remove	

2-73. HEATERS MAINTENANCE (CONT)

c. Battery Warmers (cont).

KEY

- | | |
|-------------------|------------------------|
| 1. Tie straps (4) | 6. 3-wire cord (48") |
| 2. Plastic tubing | 7. 3-wire cord (12") |
| 3. Plastic tubing | 8. Wire ties (2) |
| 4. Wire nuts (3) | 9. Battery warmers (2) |
| 5. 3-wire cord | 10. Tie straps (6) |

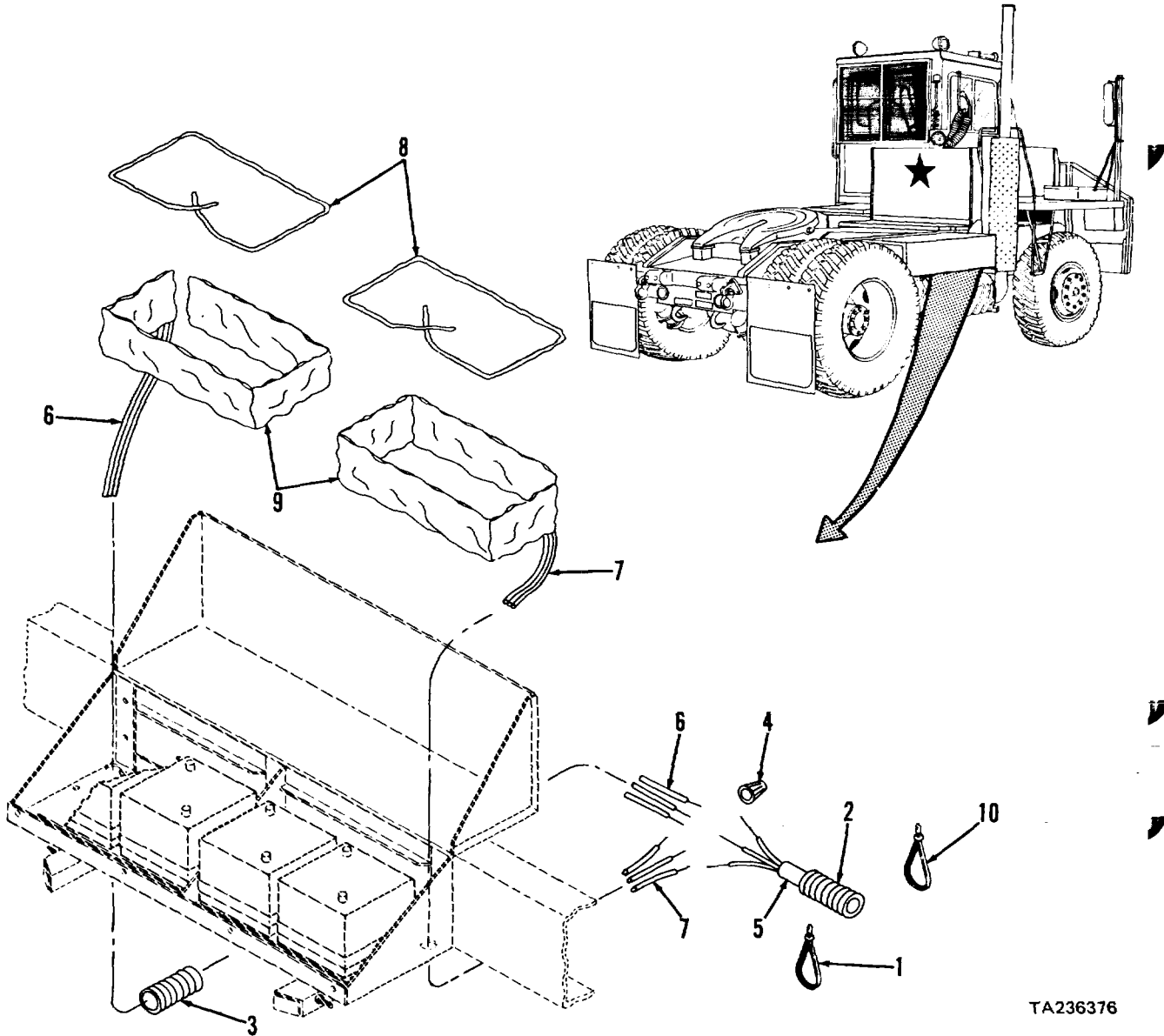

TA236376

2-73. HEATERS MAINTENANCE (CONT)

c. Battery Warmers (cont).

STEP	LOCATION	ITEM	ACTION	REMARKS
REMOVAL (cont)				
1 (cont)		f. Wire ends of 3-wire cords (5 thru 7)	Separate	Untwist
2	Battery box	a. Two wire ties (8)	Remove	Untwist; do not cut
		b. Two battery warmers (9) with 3-wire cords (6 and 7)	Remove	Lift up over batteries and pull 3-wire cords (6 and 7) from grommets in bottom of battery box
NOTE				
Perform step 3 below only if inspection indicates need for replacement of plastic tubing (2) or 3-wire cord (5).				
3	Right hand frame, rear cab guard to bumper	a. Electrical tape and six tie straps (10)	Remove	From plastic tubing (2); note locations for installation
		b. Plastic tubing (2)	Remove	Pull open at slit and remove from 3-wire cord (5)
		c. 3-wire cord (5)	Remove	Disconnect from junction box (para 2-73f)
CLEANING				
4		a. Wire nuts (4) and 3-wire cords (5, 6, and 7)	Clean	Wipe with clean, dry cloth only
		b. Plastic tubing (2 and 3) and exterior of battery warmers (9)	Clean	Use clean cloth moistened with mild detergent; dry thoroughly with clean cloths
		c. Exterior of batteries	Clean	See para 2-34a
INSPECTION				
5		a. Plastic tubing (2 and 3)	Inspect	Replace if cracked, chafed, or deteriorated
		b. 3-wire cord (5)	Inspect	Replace if jacket or insulation cracked, cut, or frayed, or if conductors corroded or broken

2-73. HEATERS MAINTENANCE (CONT)

c. Battery Warmers (cont).

STEP	LOCATION	ITEM	ACTION	REMARKS
INSPECTION (CONT)				
5 (cont)		c. Wire nuts (4) d. Wire ties (8) e. Battery warmers (9) with 3-wire cords (6 and 7)	Inspect Inspect Inspect	Replace if cracked or broken Replace if broken Replace if 3-wire cord jacket or insulation cracked, cut, or frayed, if conductors corroded or broken, or if battery warmer defective
INSTALLATION				
6	Tractor right hand frame and bumper	a. 3-wire cord (5) and plastic tubing (2) b. Six new tie straps (10) c. New electrical tape	a. Install b. Route Install Install	Para 2-73f, if removed From front spring shackle top joint to battery box In locations noted during removal Wrap around plastic tubing (2) in locations noted during removal

CAUTION

Do not overlap battery warmers in following step to prevent overheating.

7	Battery box	a. Two battery warmers (9) with 3-wire cords (6 and 7) b. Two wire ties (8) c. 3-wire cords (6 and 7)	Position Install and secure a. Cut and prepare b. Route	Wrap around batteries with "THIS SIDE IN" marking against batteries and "TOP" marking at top. Pull tightly at corners If necessary, cut cord to length shown. Discard cut end with plug; then separate wire ends and strip 1/4 inch insulation from each wire Push through grommets in bottom of battery box
8	Right hand frame rail, behind battery box	a. Plastic tubing (3)	Install	Pull open at slit and install around 3-wire cord (6)

2-73. HEATERS MAINTENANCE (CONT)

c. Battery Warmers (cont).

STEP	LOCATION	ITEM	ACTION	REMARKS
INSTALLATION (cont)				
8 (cont)				
			<u>WARNING</u>	
			Connect green wires from battery warmers to green wire from 3-wire cord (5) in following step. Incorrect wire connections, or exposed wire due to frayed insulation, can cause the engine and body of tractor to be energized at 110 Vac. Serious injury or death can result from contact with 110 Vac power.	
		b. Wire ends of 3-wire cords (5, 6, and 7)	Connect	Twist three green wires together; then twist together one black wire from each cord; then twist white wire from 3-wire cord (5) around remaining black wire ends
		c. Three wire nuts (4)	a. Install b. Tape	On twisted wire ends Wrap at least three turns of new electrical tape around each wire nut and its leads
			c. Cover	Slide plastic tubing (2 and 3) over all wires
		d. Plastic tubing (2 and 3)	Tape	Wrap new electrical tape around plastic tubing at locations noted during removal
		e. Four new tie straps (1)	Install	In locations noted during removal
9	Battery box	a. Hold-down brackets, positive and negative terminal lugs and cables	Install	Para 2-34a
		b. Battery box lid	Close and secure	Para 2-34b
		c. Spare tire mount	Raise and secure	Para 2-63c
10	Front bumper	Winterization system wiring	Test with ohmmeter	Para 2-73f

2-73. HEATERS MAINTENANCE (CONT)

d. Engine Oil Heater.

This task covers:

- a. Removal
- b. Disassembly
- c. Cleaning
- c. Inspection
- e. Reassembly
- f. Installation/

INITIAL SETUP:

Tools

No. 1 Common Organizational Maintenance Tool Kit

- Slip joint pliers
- Combination wrench set
- Screwdriver set, cross tip
- Screwdriver, flat tip
- Safety glasses

Personnel Required

Wheel Vehicle Mechanic MOS 63B

Equipment Condition

Paragraph Condition Description

Vehicle parked on level surface, engine off, and parking brake applied. Winterization system cable disconnected from junction box. Engine oil drained.

Materials/Parts

Cleaning solvent	Item 1, Appendix C	2-12b
Clean cloths	Item 2, Appendix C	
Tags	Item 14, Appendix C	
Detergent	Item 27, Appendix C	
Electrical tape	Item 37, Appendix C	
Teflon tape	Item 43, Appendix C	
Five tie straps	FSCM 96906 PN MS3667-1-9	

KEY

- | | | |
|--------------------------|------------------------|---------------------|
| 1. Strain relief | 8. Cover | 15. 3-wire cord |
| 2. Screws (2) | 9. Oil heater assembly | 16. Mounting nut |
| 3. Screw | 10. Tie straps (5) | 17. Reducer bushing |
| 4. Electrical lead (GRN) | 11. Plastic tubing | 18. Setscrew |
| 5. Wire nuts (2) | 12. Wire nuts (3) | 19. Heating element |
| 6. Electrical lead (WHT) | 13. 3-wire cord | 20. Well |
| 7. Electrical lead (BLK) | 14. Plastic tubing | |

STEP	LOCATION	ITEM	ACTION	REMARKS
------	----------	------	--------	---------

REMOVAL

WARNING

The engine oil heater operates from a 110 Vac commercial power source. Disconnect winterization system cable from receptacle at front bumper of tractor before proceeding. Serious injury or death can result from contact with energized 110 Vac power lines.

2-73. HEATERS MAINTENANCE (CONT)

d. Engine Oil Heater (cont).

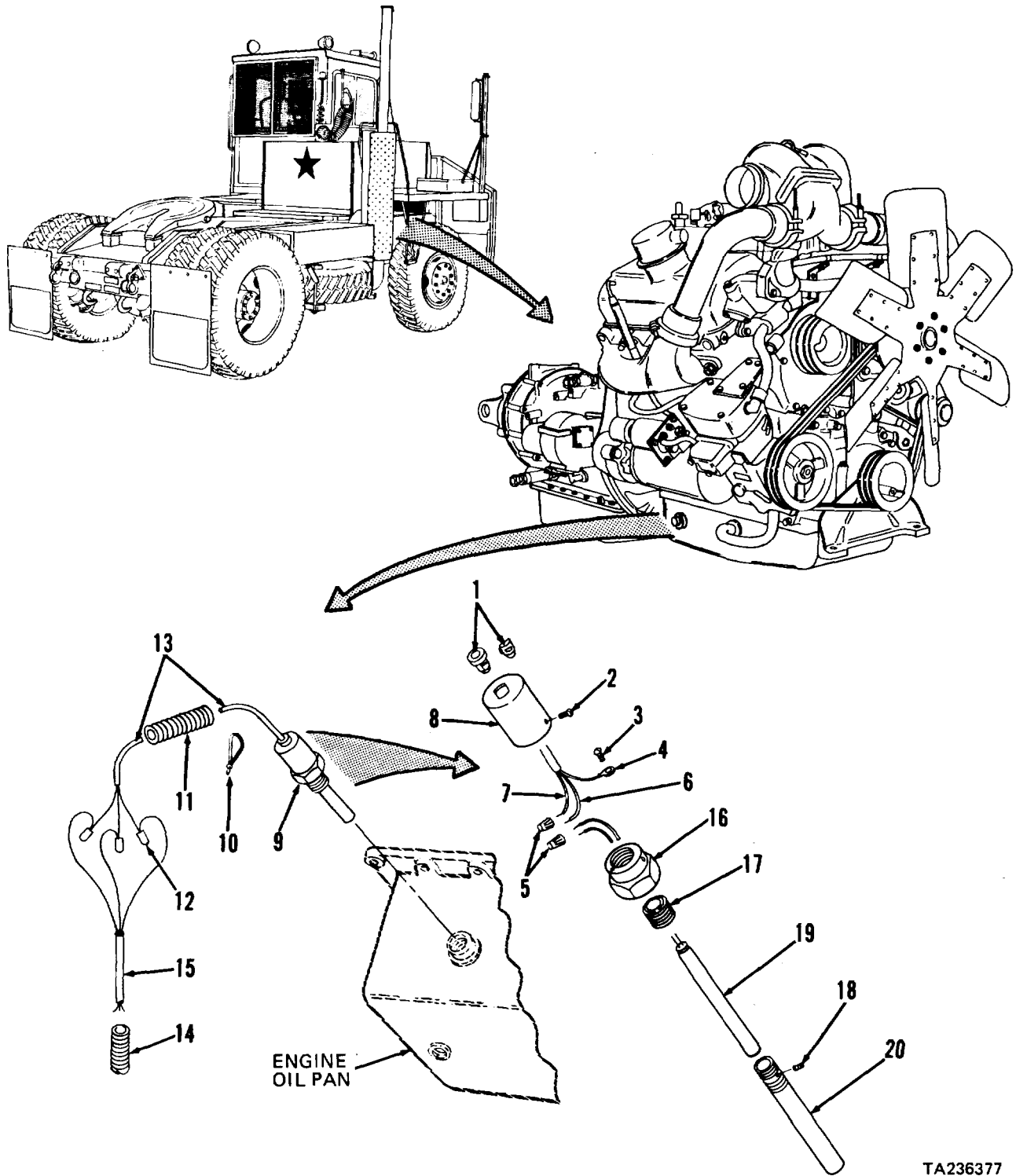

TA236377

2-73. HEATERS MAINTENANCE (CONT)

d. Engine Oil Heater (cont).

STEP	LOCATION	ITEM	ACTION	REMARKS
REMOVAL (cont)				
1	Engine oil pan, right hand side	a. Strain relief (1)	Remove	Squeeze and pull from cover (8) using pliers; then separate from 3-wire cord (13)
		b. Two screws (2)	Remove	
		c. Cover (8)	Slide back	Slide over 3-wire cord (13)
		d. Screw (3)	Remove	
		e. Electrical lead (4)	Disconnect	From mounting nut (16)
		f. Two wire nuts (5)	Remove	
		g. Electrical leads (6 and 7)	Separate	From heating element (19) leads
		h. Cover (8)	Remove	Pull from free end of 3-wire cord (13)
		i. Oil heater assembly (9)	Remove	From engine oil pan

NOTE

Perform steps 2 and 3 below only if inspection indicates replacement of 3-wire cords (13 and 15) or plastic tubing (11 and 14) is necessary.

2	3-wire cord (13)	a. Electrical tape and five tie straps (10)	Remove	From plastic tubing (19); note locations for installation
		b. Plastic tubing (11)	Remove	Pull open at slit and remove from 3-wire cord (13)
		c. Electrical tape	Remove	From wire nuts (12)
		d. Three wire nuts (12)	Remove	
		e. 3-wire cord (13)	Remove	Separate leads of 3-wire cords (13 and 15)
3	Front bumper	Plastic tubing (14) and 3-wire cord (15)	Remove	Para 2-73f

2-73. HEATERS MAINTENANCE (CONT)

d. Engine Oil Heater (cont).

STEP	LOCATION	ITEM	ACTION	REMARKS
DISASSEMBLY				
4	Well (20)	a. Mounting nut (16) and reducer bushing (17)	Remove	Unscrew from well (20)
		b. Setscrew (18)	Remove	
		c. Heating element (19)	Remove	Pull from well (20)
CLEANING				
5		a. Wire nuts (5 and 12) and 3-wire cords (13 and 15)	Clean	Wipe with clean dry cloth only
		b. Strain relief (1) and plastic tubing (11 and 14)	Clean	Use clean cloth moistened with mild detergent; dry using clean cloths

WARNING

Dry cleaning solvent (P-D-680), used to clean parts is toxic and flammable. Wear protective goggles and gloves and use only in a well ventilated area. Avoid contact with skin, eyes, and clothes and don't breathe vapors. Do not use near open flame or excessive heat and don't smoke when using it. Failure to do so could cause serious injury. If you become dizzy while using cleaning solvent, get fresh air and medical attention immediately. If contact with skin or clothes is made, flush with large amounts of water. If contact with eyes is made, wash eyes with water and seek medical aid immediately.

Compressed air must not exceed 30 psi. Wear safety glasses when drying parts with compressed air. Failure to do so could cause serious injury to eyes and possible blindness. If you hurt your eyes or if a foreign object is blown into your eyes, seek medical attention immediately.

2-73. HEATERS MAINTENANCE (CONT)

d. Engine Oil Heater (cont).

STEP	LOCATION	ITEM	ACTION	REMARKS
CLEANING (cont)				
5 (cont)		c. All other parts	Clean	Use cleaning solvent P-D-680; dry thoroughly with compressed air or clean cloths
INSPECTION				
6		a. 3-wire cords (13 and 15)	Inspect	Replace if jacket or insulation cracked, cut, or frayed, or if conductors corroded or broken
		b. Oil heater assembly (9)	Inspect	Replace if cracked, insulation frayed, or defective
		c. Plastic tubing (11 and 14)	Inspect	Replace if cracked, chafed, or deteriorated
		d. All other parts	Inspect	Replace if cracked, broken, or threads damaged
REASSEMBLY				
7	Well (20)	a. Heating element (19)	Position	In well (20)
		b. Setscrew (18)	Install and tighten	
		c. Mounting nut (16) and reducer bushing (17)	Install and tighten	On well (20)
INSTALLATION				
8	Front bumper	3-wire cord (15) and plastic tubing (14)	Install, if	Para 2-73f removed

WARNING

Be sure you twist together the same color wire ends in the following step. Connect green-to-green, white (or gray)-to-white, and black (or remaining color)-to-black. Incorrect connections or exposed conductors can cause the engine and body of the tractor to be energized at 110 Vac. Serious injury or death can result from contact with 110 Vac power.

2-73. HEATERS MAINTENANCE (CONT)

d. Engine Oil Heater (cont).

STEP	LOCATION	ITEM	ACTION	REMARKS
INSTALLATION (cont)				
9	3-wire cord (13)	a. 3-wire cord (13)	Connect to 3-wire cord (15)	Twist together green wire ends; then twist white wire ends together; then twist together black wire ends
		b. Three wire nuts (12)	a. Install b. Tape	On twisted wire ends Wrap at least three turns of new electrical tape around each wire nut and its leads
		c. Plastic tubing (11)	Position	Pull open at slit and install around 3-wire cord (13)
		d. New electrical tape	Install	Wrap around plastic tubing (11) in locations noted during removal
		e. Five new tie straps (10)	Install	In locations noted during removal
10	Engine oil pan, right hand side	a. Oil heater assembly (9)	a. Tape threads b. Install and tighten	Wrap threads with Teflon tape before installation
		b. Cover (8)	Position	Slide onto free end of 3-wire cord (13)

WARNING

You must attach the green electrical lead (4) securely in steps 10c and 10d below. Loose or incorrect connection can cause the engine and body of the tractor to be energized at 110 Vac. Serious injury or death can result from contact with 110 Vac power.

c. Electrical lead (4)	Position	On mounting nut (16)
d. Screw (3)	Install and tighten	
e. Electrical lead (6)	Connect	To either lead of heating element (19); twist wire ends together
f. Electrical lead (7)	Connect	To remaining lead of heating element (19); twist wire ends together

2-73. HEATERS MAINTENANCE (CONT)

d. Engine Oil Heater (cont).

STEP	LOCATION	ITEM	ACTION	REMARKS
INSTALLATION (cont)				
10 (cont)		g. Two wire nuts (5)	Install and tighten	On twisted wire ends
		h. Cover (8)	Position	Align holes in cover with holes in mounting nut (16)
		i. Two screws (2)	Install and tighten	Secures cover (8)
		j. Strain relief (1)	Install	Position around jacket of 3- wire cord (13) near cover (8); then squeeze with pliers and push into cover
11	Engine	Engine crankcase	Fill	Para 2-12b
12	Front bumper	Winterization system wiring	Test with ohmmeter	Para 2-73f

2-73. HEATERS MAINTENANCE (CONT)

- e. Coolant Heater and Pump.

This task covers:

- | | |
|----------------|-----------------|
| a. Removal | c. Inspection |
| b. Disassembly | e. Reassembly |
| c. Cleaning | f. Installation |

INITIAL SETUP:

Tools

No. 1 Common Organizational Maintenance

Tool Kit

- Screwdriver, flat tip
- Screwdriver set, cross tip
- Adjustable open end wrench
- Combination wrench set
- Slip joint pliers
- Scratch wire brush
- Safety glasses
- Tool kit, electrical connector
- Crimping tool
- Wire stripper

Electrical tape

Item 37, Appendix C

Antiseize

 compound

Item 38, Appendix C

Tie straps

FSCM 96906 PN MS3667-1-9

Three wire

connectors

FSCM 11117 PN B2H

Personnel Required

Wheel Vehicle Mechanic MOS 63B

Equipment Condition

Paragraph	Condition Description
-----------	-----------------------

Materials/Parts

Cleaning

 solvent

Item 1, Appendix C

Clean cloths

Item 2, Appendix C

Tags

Item 14, Appendix C

Detergent

Item 27, Appendix C

2-15a(1)

Vehicle parked on level surface, engine off, and parking brake applied.

Winterization system cable disconnected from junction box.

Cooling system drained.

STEP	LOCATION	ITEM	ACTION	REMARKS
------	----------	------	--------	---------

REMOVAL

WARNING

Coolant heater and pump operate from a 110 Vac commercial power source. Disconnect winterization system cable from receptacle at front bumper of tractor before proceeding. Serious injury or death can result from contact with energized 110 Vac power lines.

1	Engine block, left side	a. Clamp (2) b. Hose (1) c. Clamp (2) d. Fitting (40)	Loosen Disconnect Remove Remove	Pull from fitting (40) From hose (1) From engine block
2	Engine oil cooler	a. Clamp (4) b. Hose (3)	Loosen Disconnect	Pull from fitting (37)

2-73. HEATERS MAINTENANCE (CONT)

e. Coolant Heater and Pump (cont).

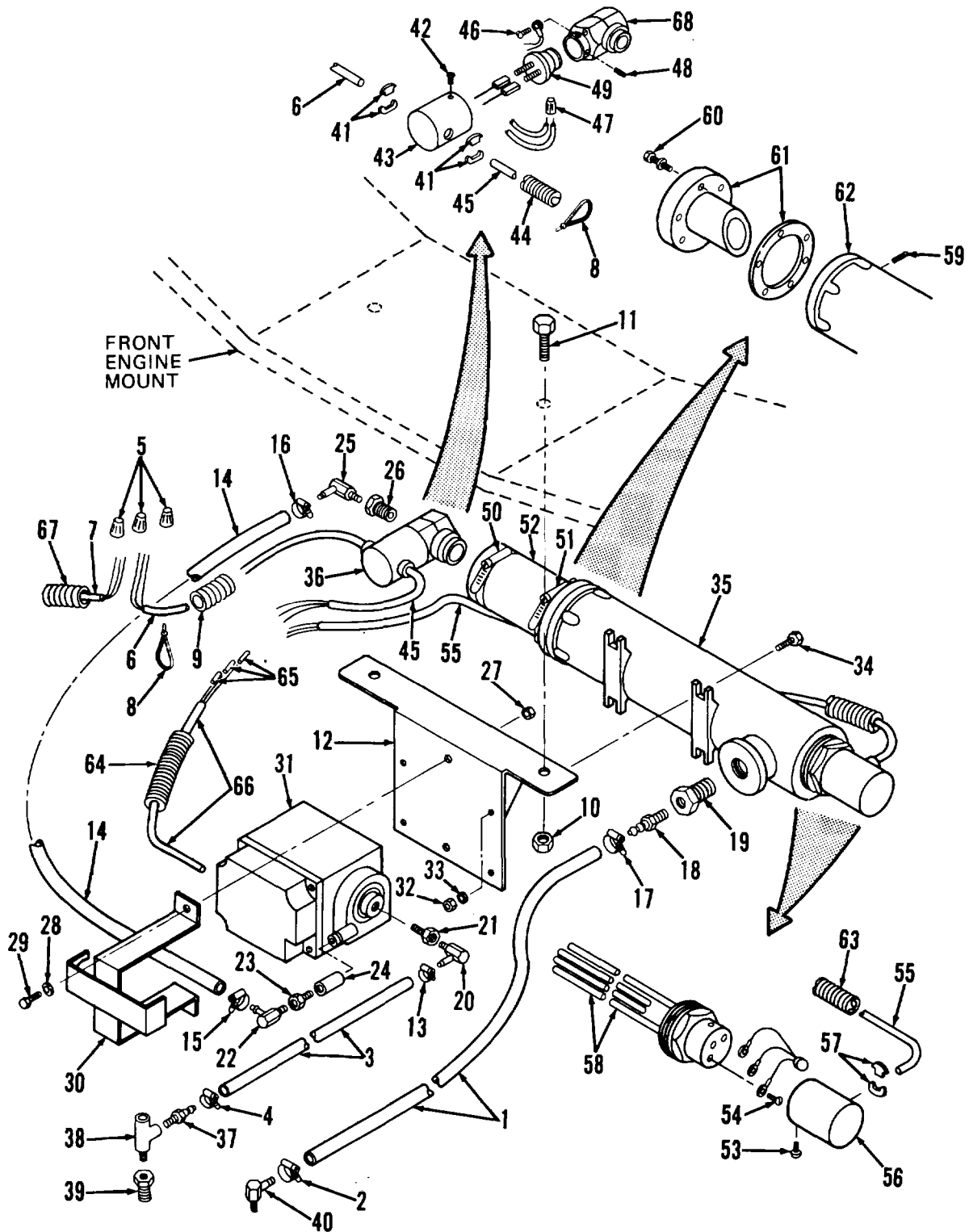

2-73. HEATERS MAINTENANCE (CONT)

e. Coolant Heater and Pump (cont).

KEY

- | | | |
|----------------------------|--------------------------|-----------------------------|
| 1. Hose | 24. Coupling | 47. Wire nut |
| 2. Clamp | 25. Fitting | 48. Setscrews (2) |
| 3. Hose | 26. Reducer bushing | 49. Sensor |
| 4. Clamp | 27. Locknuts (2) | 50. Clamp |
| 5. Wire nuts (3) | 28. Washers (2) | 51. Clamp |
| 6. 3-wire cord | 29. Capscrews (2) | 52. Hose |
| 7. 3-wire cord | 30. Pump support bracket | 53. Screws (2) |
| 8. Tie straps (1) | 31. Pump | 54. Screws (3) |
| 9. Plastic tubing | 32. Locknuts (4) | 55. 3-wire cord |
| 10. Locknuts (2) | 33. Washers (4) | 56. Cover |
| 11. Capscrews (2) | 34. Capscrews (4) | 57. Strain relief |
| 12. Heater support bracket | 35. Heater assembly | 58. Heater element |
| 13. Clamp | 36. Thermostat | 59. Plug |
| 14. Hose | 37. Fitting | 60. Capscrews (6) |
| 15. Clamp | 38. Tee | 61. Head and valve assembly |
| 16. Clamp | 39. Reducer bushing | 62. Heater tank |
| 17. Clamp | 40. Fitting | 63. Plastic tubing |
| 18. Fitting | 41. Strain reliefs (2) | 64. Plastic tubing |
| 19. Reducer bushing | 42. Screws (2) | 65. Wire connectors (3) |
| 20. Fitting | 43. Cover | 66. 3-wire cord |
| 21. Reducer bushing | 44. Plastic tubing | 67. Plastic tubing |
| 22. Fitting | 45. 3-wire cord | 68. Base |
| 23. Reducer bushing | 46. Screw | |

STEP	LOCATION	ITEM	ACTION	REMARKS
------	----------	------	--------	---------

REMOVAL (cont)

2 (cont)		c. Clamp (4)	Remove	From hose (3)
		d. Radiator hose	Disconnect	From tee (38); para 2-15c
		e. Fitting (37), tee (38), and reducer bush- ing (39)	Remove	From engine oil cooler
3	Tractor, right hand front, underside	a. Electrical tape	Remove	From plastic tubing (9 and 67); note locations for installation
		b. Three tie straps (8)	Cut and remove	Note locations for installa- tion; discard tie straps
		c. Plastic tubing (9)	Remove	Pull open at slit and remove from 3-wire cord (6)
		d. Plastic tubing (67)	Move	Slide until wire nuts (5) are accessible
		e. Electrical tape	Remove	From wire nuts (5)

2-73. HEATERS MAINTENANCE (CONT)

e. Coolant Heater and Pump (cont).

STEP	LOCATION	ITEM	ACTION	REMARKS
REMOVAL (cont)				
3 (cont)				
NOTE				
Tag and identify all wires before disconnecting and removing.				
		f. 3-wire cords (6 and 7)	Tag wires	
		g. Three wire nuts (5)	Remove	
		h. Wire ends of 3-wire cords (6 and 7)	Separate	Untwist
4	Front engine mount	a. Two locknuts (10)	Remove	Support coolant heater and pump assembly
		b. Heater support bracket (12) with heater, pump, hoses, and wires	Remove	As an assembly
		c. Two capscrews (11)	Remove	Only if necessary for replacement
5	Front bumper	Plastic tubing (67) and 3-wire cord (7)	Remove, if necessary	Para 2-73f

DISASSEMBLY

6	Heater assembly (35) and pump (31)	a. Clamp (13)	Loosen	
		b. Hose (3)	Disconnect	
		c. Clamp (13)	Remove	From hose (3)
		d. Clamp (15)	Loosen	
		e. Hose (14)	Disconnect	
		f. Clamp (15)	Remove	From hose (14)
		g. Clamp (16)	Loosen	
		h. Hose (14)	Disconnect	From fitting (25)
		i. Clamp (16)	Remove	From hose (14)
		j. Clamp (17)	Loosen	
		k. Hose (1)	Disconnect	From fitting (18)
		l. Clamp (17)	Remove	From hose (1)
		m. Fitting (18)	Remove	
		n. Reducer bushing (19)	Remove	

2-73. HEATERS MAINTENANCE (CONT)

e. Coolant Heater and Pump (cont).

STEP	LOCATION	ITEM	ACTION	REMARKS
DISASSEMBLY (cont)				
6 (cont)	t)	o. Fitting (20)	Remove	
		p. Reducer bushing (21)	Remove	
		q. Fitting (22)	Remove	
		r. Reducer bushing (23)	Remove	
		s. Coupling (24)	Remove	
		t. Fitting (25)	Remove	
		u. Reducer bushing (26)	Remove	
		v. Two locknuts (27), washers (28), and capscrews (29)	Remove	
		w. Pump support bracket (30) and pump (31)	Remove	From heater support bracket (12)
		x. Four locknuts (32), washers (33), and capscrews (34)	Remove	
		y. Heater assembly (35) with thermostat (36)	Remove	From heater support bracket (12)
7 (36)	Thermostat	a. Two strain reliefs (41)	Remove	Squeeze and pull from cover (43) using pliers; then separate from 3-wire cords (6 and 45)
		b. Two screws (42)	Remove	
		c. Cover (43)	Slide back	Slide until 3-wire cords (6 and 45) terminal ends are accessible
		d. 3-wire cords (6 and 45)	a. Tag	
		e. Screw (46)	b. Disconnect	Unplug from sensor (49)
		f. Wire nut (47)	Remove	
		g. 3-wire cords (6 and 45)	Remove	Separate wire ends and pull from cover (43)
		h. Two setscrews (48)	Remove	
		i. Sensor (49)	Remove	Pull from base (68)
		j. Clamp (50)	Loosen	

2-73. HEATERS MAINTENANCE (CONT)

e. Coolant Heater and Pump (cont).

STEP	LOCATION	ITEM	ACTION	REMARKS
DISASSEMBLY (cont)				
8	Heater assembly (35)	k. Base (68)	Remove	Pull from hose (52)
		l. Two clamps (50 and 51)	Loosen and	Slide from hose (52) remove
		m. Hose (52)	Remove	
		a. Strain relief (57)	Remove	Squeeze and pull from cover (56) using pliers; then separate from 3-wire cord (55)
		b. Two screws (53)	Remove	
		c. Cover (56)	Slide back	Slide over 3-wire cord (55) until three screws (54) are accessible
		d. Three screws (54)	Remove	
		e. 3-wire cord (55)	a. Tag b. Separate	Disconnect from heater element (58); then pull from cover (56)
		f. Heater element (58)	Remove	Unscrew from heater tank (62)
		g. Plug (59)	Remove	From heater tank (62)
	h. Six capscrews (60) and head and valve assembly (61)	Remove	From heater tank (62)	
9	Pump (31)	a. Electrical tape	Remove	From plastic tubing; note locations for installation
		b. Plastic tubing (44, 63, and 64)	Remove	Pull open at slits and remove from 3-wire cords (45, 55, and 66)
		c. Electrical tape	Remove	From wire connectors (65)
		d. Three wire connectors (65)	Remove	Only if inspection indicates replacement of pump (31) or 3-wire cords (45, 55, or 66) is necessary; cut wire as close to connectors as possible
		e. 3-wire cords (45 and 55)	Remove	
		f. 3-wire cord (66) with pump (31)	Remove	

2-73. HEATERS MAINTENANCE (CONT)

e. Coolant Heater and Pump (cont).

STEP	LOCATION	ITEM	ACTION	REMARKS
CLEANING				
10		a. Hoses (1, 3, 14, and 52), 3-wire cords (6, 7, 45, 55, and 66), and wire nuts (5 and 47)	Clean	Wipe with clean, dry cloth
		b. Strain reliefs (41 and 57) and plastic tubing (9, 44, 63, 64, and 67)	Clean	Use clean cloth moistened with mild detergent; dry using clean cloths
		c. Heater element (58)	Clean	Scrape off all scale accumulation with stiff bristled brush; then wipe with clean cloth

WARNING

Dry cleaning solvent (P-D-680), used to clean parts is toxic and flammable. Wear protective goggles and gloves and use only in a well ventilated area. Avoid contact with skin, eyes, and clothes and don't breathe vapors. Do not use near open flame or excessive heat and don't smoke when using it. Failure to do so could cause serious injury. If you become dizzy while using cleaning solvent, get fresh air and medical attention immediately. If contact with skin or clothes is made, flush with large amounts of water. If contact with eyes is made, wash eyes with water and seek medical aid immediately.

Compressed air must not exceed 30 psi. Wear safety glasses when drying parts with compressed air. Failure to do so could cause serious injury to eyes and possible blindness. If you hurt your eyes or if a foreign object is blown into your eyes, seek medical attention immediately.

d. All other parts	Clean	Use cleaning solvent P-D-680; dry with compressed air
--------------------	-------	---

2-73. HEATERS MAINTENANCE (CONT)

e. Coolant Heater and Pump (cont).

STEP	LOCATION	ITEM	ACTION	REMARKS
INSPECTION				
11		a. Hoses (1, 3, 14, and 52)	Inspect	Replace if cracked or broken. Clear clogged hoses with compressed air at 30 psi
		b. 3-wire cords (6, 7, 45, 55, and 66)	Inspect	Replace if jacket or insulation cracked, cut, or frayed, or if conductors corroded or broken
		c. Plastic tubing (9, 44, 63, 64, and 67)	Inspect	Replace if cracked, chafed, or deteriorated
		d. Pump (31)	Inspect	Replace if deeply gouged or dented, threads damaged, or wiring or pump defective
		e. Heater (35)	Inspect	Replace if deeply gouged or dented, cracked, broken, or otherwise damaged
		f. Heater element (58)	Inspect	Replace heater assembly (35) if cracked, broken, or defective
		g. All other parts	Inspect	Replace if cracked, broken, distorted, or threads damaged
REASSEMBLY				
12	Heater tank (62)	a. Heater element (58)	a. Coat threads	Use antiseize compound
			b. Install	In heater tank (62); rotate clockwise
		b. Head and valve assembly (61)	Position	On heater tank (62)
		c. Six capscrews (60)	Install and tighten	
		d. Plug (59)	Install and tighten	
		e. Cover (56)	Position	Slide onto 3-wire cord (55)

WARNING

You must attach the green ground wire securely in the following steps. Loose or incorrect connection can cause the engine and body of the tractor to be energized at 110 Vac. Serious injury or death can result from contact with 110 Vac power.

2-73. HEATERS MAINTENANCE (CONT)

e. Coolant Heater and Pump (cont).

STEP	LOCATION	ITEM	ACTION	REMARKS
REASSEMBLY (cont)				
12 (cont)		f. 3-wire cord (55) wire ends	Position	On heater element (58) as tagged (green ground wire at center terminal)
		g. Three screws (54)	Install and tighten	Secures wire ends
		h. Cover (56)	Position	Align holes in cover (56) with holes in heater element (58)
		i. Two screws (53)	Install and tighten	Secures cover (56)
		j. Strain relief (57)	Install	Position around jacket of 3-wire cord (55) near cover (56); then squeeze with pliers and push into cover
		k. Hose (52)	Position	
		l. Clamp (51)	Install and tighten	
13	Thermostat (36)	m. Clamp (50)	Install	Do not tighten
		a. Sensor (49)	Position	In base (68)
		b. Two setscrews (48)	Install and tighten	Secures sensor (49)
		c. Base (68)	Install	On hose (52)
		d. Clamp (50)	Tighten	

WARNING

Be sure you twist together the same color wire ends in the following step. Connect green-to-green, white (or gray)-to-white, and black (or remaining color)-to-black. Incorrect connections or exposed conductors can cause the engine and body of the tractor to be energized at 110 Vac. Serious injury or death can result from contact with 110 Vac power.

e. Cover (43)	Position	Slide onto 3-wire cords (6 and 45) until terminals are exposed
f. 3-wire cords (6 and 45)	Connect	As tagged (plug one terminal end of each cord into thermostat sensor (49); connect green wire terminals; twist remaining wire ends together)

2-73. HEATERS MAINTENANCE (CONT)

e. Coolant Heater and Pump (cont).

STEP	LOCATION	ITEM	ACTION	REMARKS
REASSEMBLY (cont)				
13 (cont)		g. Screw (46)	Install	Secures green ground wires to base (68)
		h. Wire nut (47)	Install and tighten	On twisted wire ends
		i. Cover (43)	Position	Align holes in cover (43) with holes in base (68)
		j. Two screws (42)	Install and tighten	Secures cover (43)
		k. Two strain reliefs (41)	Install	Position around jackets of 3-wire cords (6 and 45) near cover (43); then squeeze with pliers and push into cover
14	Heater assembly (35)	a. Heater assembly (35) with thermostat (36)	Position (12)	On heater support bracket
		b. Four capscrews (34), washers (33), and locknuts (32)	Install and tighten	
		c. Reducer bushing (19) and fitting (18)	a. Coat threads	Use antiseize compound
		d. Clamps (2 and 17)	b. Install	
		e. Hose (1)	Position	Slide onto hose (1); do not tighten
		f. Clamp (17)	Connect	Push onto fitting (15)
		g. Reducer bushing (26) and fitting (25)	Tighten	
15 (31)	Pump	a. Reducer bushing (21) and coupling (24)	Install and tighten	
		b. Fitting (20), reducer bushing (23), and fitting (22)	a. Coat threads b. Install and tighten	Use antiseize compound
		c. Pump (31) and pump support bracket (30)	Position (12)	On heater support bracket

2-73. HEATERS MAINTENANCE (CONT)

e. Coolant Heater and Pump (cont).

STEP	LOCATION	ITEM	ACTION	REMARKS
REASSEMBLY (cont)				
15 (cont)		d. Two capscrews (29), washers (28), and locknuts (27)	Install and tighten	
16	Heater assembly (35) and pump (31)	a. Two clamps (15 and 16)	Position	Slide onto hose (14)
		b. Hose (14)	Connect	Push onto fittings (22 and 25)
		c. Two clamps (15 and 16)	Tighten	
		d. Two clamps (4 and 13)	Position	Slide onto hose (3)
		e. Hose (3)	Connect	To fitting (20)
		f. Clamp (13)	Tighten	
17	Heater assembly (35)	a. 3-wire cords (45, 55, and 66)	a. Strip wires	If necessary, strip 5/8 inch insulation from each wire

WARNING

Be sure you twist together the correct wire ends as specified in the following step. Connect green-to-green, white (or gray)-to-white, and black (or remaining color)-to-black. Incorrect connections or exposed conductors can cause the engine and body of the tractor to be energized at 110 Vac. Serious injury or death can result from contact with 110 Vac power.

b. Connect wire ends

Twist together as tagged:

- a. Green wires of cords (45 and 55) and green/yellow wire of cord (66)
- b. Either black wires of cords (45 and 55) and blue wire of cord (66)
- c. Remaining black wires of cords (45 and 55) and brown wire of cord (66)

2-73. HEATERS MAINTENANCE (CONT)

e. Coolant Heater and Pump (cont).

STEP	LOCATION	ITEM	ACTION	REMARKS
REASSEMBLY (cont)				
17 (cont)		b. Three new wire connectors (65)	a. Install	Crimp connectors onto twisted wire ends
			b. Tape	Wrap at least three turns of new electrical tape around each wire connector and its leads
		c. Plastic tubing (44, 63, and 64)	a. Install	Pull open at slits and install over 3-wire cords (45, 55, and 66)
			b. Tape	Wrap new electrical tape around plastic tubing at locations noted during removal

INSTALLATION

18	Front bumper	3-wire cord (7) and plastic tubing (67)	Install, if removed	Para 2-73f
19	Front engine mount	a. Heater support bracket (12) with heater, pump, hoses, and wires	Position	As an assembly
		b. Two capscrews (11) and locknuts (10)	Install and tighten	

WARNING

Be sure you twist together the same color wire ends in the following step. Connect green-to-green and black-to-black. Incorrect connections or exposed conductors can cause the engine and body of the tractor to be energized at 110 Vac. Serious injury or death can result from contact with 110 Vac power.

c.	3-wire cords (6 and 7)	Connect	As tagged; twist wire ends (green to green, black to black, black to black)
----	------------------------	---------	---

12-73. HEATERS MAINTENANCE (CONT)
--

e. Coolant Heater and Pump (cont).

STEP	LOCATION	ITEM	ACTION	REMARKS
INSTALLATION (cont)				
19 (cont)		d. Three wire nuts (5)	a. Install b. Tape	On twisted wire ends Wrap at least three turns of new electrical tape around each wire nut and its leads
		e. Plastic tubing (9)	a. Install b. Tape	Pull open at slit and install over 3-wire cord (6) Wrap new electrical tape around plastic tubing at locations noted during removal
		f. Three new tie straps (8)	Install	Around plastic tubing (9 and 44) at locations noted during removal
20	Engine oil cooler	a. Reducer bushing (39), tee (38), and fitting (37)	Install and tighten	In engine oil cooler
		b. Radiator hose	Install	On tee (38); para 2-15c
		c. Hose (3)	Connect	Push onto fitting (37)
		d. Clamp (4)	Tighten	
21	Engine block, left side	a. Fitting (40)	Install	In engine block
		b. Hose (1)	Connect	Push onto fitting (40)
		c. Clamp (2)	Tighten	
22	Tractor	Cooling system	Fill	Para 2-15a(1)
23	Front bumper	Winterization system wiring	Test with ohmmeter	Para 2-73f

2-73. HEATERS MAINTENANCE (CONT)

f. Junction Box.

This task covers:

- a. Removal
- b. Cleaning
- c. Inspection
- d. Installation
- e. Testing

INITIAL SETUP:

Tools

- No. 1 Common Organizational Maintenance Tool Kit
 - Adjustable open end wrench
 - Socket wrench set
 - Screwdriver
 - Screwdriver set
 - Safety glasses

Materials/Parts

- Cleaning solvent Item 1, Appendix C
- Clean cloths Item 2, Appendix C
- Tags Item 14, Appendix C
- Electrical tape Item 37, Appendix C

Personnel Required

Wheel Vehicle Mechanic MOS 63B

Equipment Condition

Paragraph Condition Description

Parked on level surface; engine off, and parking brake applied.
Winterization system cable disconnected from junction box.

STEP	LOCATION	ITEM	ACTION	REMARKS
------	----------	------	--------	---------

REMOVAL

WARNING

The winterization heaters operate from a 110 Vac commercial power source. Disconnect winterization system cable from receptacle at front bumper of tractor before proceeding. Serious injury or death can result from contact with energized 110 Vac power lines.

NOTE

Perform steps 1a and 1b below if necessary to remove door. If door is removed, proceed directly to step 1c below.

1	Inside front bumper, right side	a. Latch (15)	Rotate	90 degrees
		b. Door (1)	Remove	Slide down
		c. Nut (2) and clamp (3)	Remove	From bumper
		d. Electrical tape	Remove	Note locations for installation
		e. Plastic tubing (4)	Remove	Pull open at slit and remove from cord sets

2-73. HEATER MAINTENANCE (CONT)

f. Junction Box (cont).

KEY

- 1. Door
- 2. Nut
- 3. Clamp
- 4. Plastic tubing
- 5. Screws (2)
- 6. Shell halves (2)
- 7. Screw
- 8. Connector insert
- 9. Nut
- 10. Rubber washer
- 11. Nut
- 12. Strain relief connector
- 13. Locknut
- 14. Capscrew
- 15. Latch
- 16. Washer
- 17. Locknuts (4)
- 18. Washers (4)
- 19. Capscrews (4)
- 20. Junction box

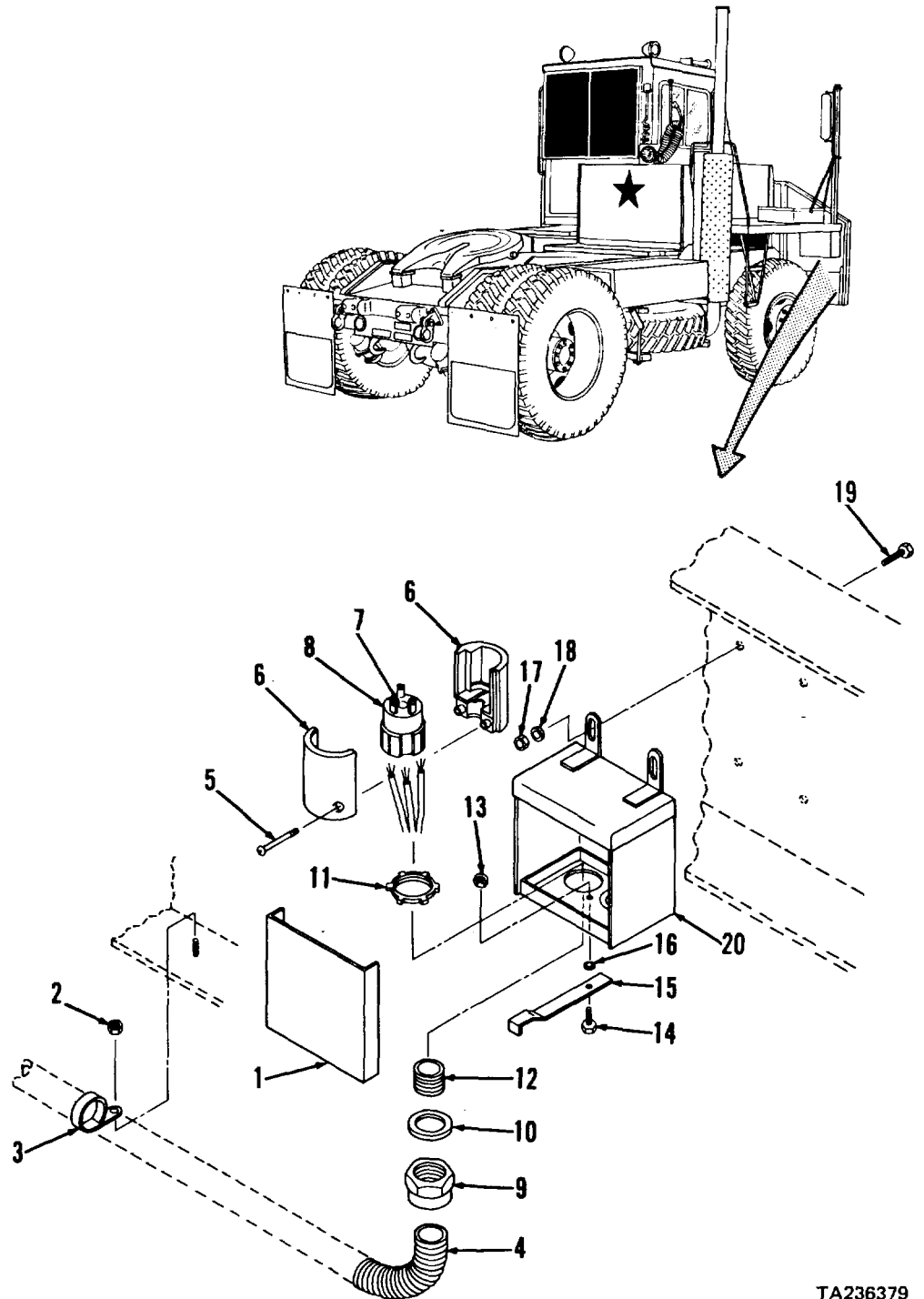

TA236379

2-73. HEATERS MAINTENANCE (CONT)

f. Junction Box (cont).

STEP	LOCATION	ITEM	ACTION	REMARKS
REMOVAL (cont)				
2	Junction box (20)	a. Two screws (5) b. Two shell halves (6)	Remove Remove	Separate from connector insert (8)

CAUTION

Do not attempt to remove screw (7) or disassemble connector insert (8) in the following steps.

c. Screw (7)	Loosen only
--------------	-------------

NOTE

Tag cord set wires at rear of connector to aid in reassembly.

d. Cord set wires	Disconnect	Pull out from rear of connector insert (8). Set connector insert aside
e. Nut (9)	Loosen	Slide over three cord sets
f. Three cord sets	Remove	Pull from bottom of strain relief connector (12)
g. Nut (9) and rubber washer (10)	Remove	
h. Nut (11) and strain relief connector (12)	Remove	
i. Locknut (13), capscrew (14), latch (15), and washer (16)	Remove	
j. Four locknuts (17), washers (18), and capscrews (19)	Remove	Support junction box (20)
k. Junction box (20)	Remove	

2-73. HEATERS MAINTENANCE (CONT)

f. Junction Box (cont).

STEP	LOCATION	ITEM	ACTION	REMARKS
CLEANING				
3		a. Plastic tubing (4), shell halves (6), and connector insert (8)	Clean	Wipe with clean, dry cloth

WARNING

Dry cleaning solvent (P-D-680), used to clean parts is toxic and flammable. Wear protective goggles and gloves and use only in a well ventilated area. Avoid contact with skin, eyes, and clothes and don't breathe vapors. Do not use near open flame or excessive heat and don't smoke when using it. Failure to do so could cause serious injury. If you become dizzy while using cleaning solvent, get fresh air and medical attention immediately. If contact with skin or clothes is made, flush with large amounts of water. If contact with eyes is made, wash eyes with water and seek medical aid immediately.

Compressed air must not exceed 30 psi. Wear safety glasses when drying parts with compressed air. Failure to do so could cause serious injury to eyes and possible blindness. If you hurt your eyes or if a foreign object is blown into your eyes, seek medical attention immediately.

b. All other parts	Clean	Use cleaning solvent P-D-680. Dry with compressed air
--------------------	-------	--

INSPECTION

4		a. Plastic tubing (4)	Inspect	Replace if cracked, chafed, or deteriorated
		b. Door (1), latch (15), and junction box (20)	Inspect	Replace if cracked, corroded, distorted, or otherwise damaged
		c. Connectors (5 thru 8)	Inspect	Replace if cracked, contacts corroded or broken, or otherwise damaged
		d. Strain relief assembly (9 thru 12)	Inspect	Replace if rubber washer (10) cracked or corroded, or if threads damaged

2-73. HEATERS MAINTENANCE (CONT)

f. Junction Box (cont).

STEP	LOCATION	ITEM	ACTION	REMARKS
INSPECTION (cont)				
4 (cont)		e. All other parts	Inspect	Replace if cracked, broken, distorted, or threads damaged
INSTALLATION				
5	Inside front bumper, right side	a. Junction box b. Four capscrews (19), washers (18), and locknuts (17)	Position Install and tighten	Inside front bumper Secures junction box (20)
6	Junction box (20)	a. Capscrew (14), latch (15), washer (16), and locknut (13) b. Strain relief connector (12) c. Nut (11) d. Nut (9) and rubber washer (10)	Install and tighten Position Install and tighten Position	So latch (15) rotates freely At bottom of junction box (20) Slide over free ends of three cord sets

WARNING

Be sure you twist together the same color wire ends in the following step. Connect green-to-green, white (or gray)-to-white, and black (or remaining color)-to-black. Incorrect connections or exposed conductors can cause the engine and body of the tractor to be energized at 110 Vac. Serious injury or death can result from contact with 110 Vac power.

e. Cord set wires	a. Position	Push wire ends through strain relief connector (12)
	b. Twist together	Twist three green wires together; then three white wires; then three black wires

2-73. HEATERS MAINTENANCE (CONT)

f. Junction Box (cont).

STEP	LOCATION	ITEM	ACTION	REMARKS
------	----------	------	--------	---------

INSTALLATION (cont)

6
(cont)

WARNING

You must attach the green electrical leads securely in the following step. Loose or incorrect connection can cause the engine and body of the tractor to be energized at 110 Vac. Serious injury or death can result from contact with 110 Vac power.

			c. Install in connector insert (8)	Push leads of green wires in slot marked GROUND (L-shaped prong); install white and black wires according to tags installed during removal
		f. Screw (7)	Tighten	Secures cord set wires
		g. Two shell halves (6)	Position	Over connector insert (8)
		h. Two screws (5)	Install and tighten	Secures shell halves (6)
		i. Rubber washer (10) and nut (9)	Install and tighten	Secures cord sets
7	Inside front bumper	a. Plastic tubing (4)	Position	Over three cord sets
		b. New electrical tape	Install	Wrap around plastic tubing (4) in locations noted during removal
		c. Clamp (3)	Install	Spread over plastic tubing (4) and position on bumper stud
		d. Nut (2)	Install and tighten	

NOTE

Don't install door (1) at this time. Go to step 8 below.

2-73. HEATERS MAINTENANCE (CONT)

f. Junction Box (cont).

STEP	LOCATION	ITEM	ACTION	REMARKS
TESTING				
8	Junction box (20)	a. Ohmmeter with test leads	a. Set to X1 range b. Connect one lead to L-shaped prong of connector insert (8) c. Connect remaining lead to either straight prong of connector insert d. Note ohmmeter reading. Ohmmeter must indicate open circuit (infinity) e. Disconnect ohmmeter lead from straight prong and connect to remaining straight prong f. Note ohmmeter reading. Ohmmeter must indicate open circuit (infinity) g. Disconnect ohmmeter leads from connector insert (8)	

WARNING

If ohmmeter indicates continuity in either test above, check for short circuit or incorrect wiring. Do not apply power to connector insert (8) until problem is corrected to prevent severe electrical shock.

- | | | |
|---------------|-----------------------|------------------|
| b. Door (1) | Install | Slide up |
| c. Latch (15) | Rotate under door (1) | Secures door (1) |

2-74. DATA AND INSTRUCTION PLATES MAINTENANCE

This task covers cleaning, inspection, and replacement.

INITIAL SETUP:

Tools

No. 1 Common Organizational Maintenance
Tool Kit
Screwdriver
Soft brush

Equipment Condition

Paragraph Condition Description

Vehicle parked on level surface, engine off, and parking brake applied.

Materials/Parts

Detergent Item 27, Appendix C

Personnel Required

Wheel Vehicle Mechanic MOS 63B

STEP	LOCATION	ITEM	ACTION	REMARKS
------	----------	------	--------	---------

CLEANING AND INSPECTION

NOTE

See illustration for appearance and location of decal or plate.

1		Plate	a. Check for security	Secure if loose
			b. Clean	Clean using soft brush and mild detergent solution

REPLACEMENT

2		a. Fasteners b. Plate or decal	Remove	As required
			a. Remove	
			b. Install c. Secure	

2-74. DATA AND INSTRUCTION PLATES MAINTENANCE (CONT)

KEY

1. Unlatch control caution decal
2. Drive train data decal
3. Operating instructions decal
4. Reverse range caution decal
5. Rustproofing data decal
6. Towing caution decal
7. Torque converter light decal
8. Sound level decal
9. Lubrication chart decal
10. Warranty decal
11. Lift and tiedown decal
12. Cab tilt instructions decal
13. Unlatch control instructions decal
14. Screws (4)
15. Vehicle identification plate
16. Clear vinyl cover
17. On-road decal
18. Alcohol reservoir decal
19. Inverter identification decal
20. Low fuel light decal
21. Emergency exit decal
22. Floodlight switches decal
23. Warning lights decal
24. PTO warning decal
25. PTO decal
26. Quick start decal
27. Circuit breaker panel decal
28. Cab tilt pump warning decal
29. Cab tilt caution decal
30. Electrical schematic decal
31. Coolant reservoir caution decal
32. Screws (2)
33. Emergency air plate
34. Screws (2)
35. Service air plate
36. Screws (2)
37. Electrical plate

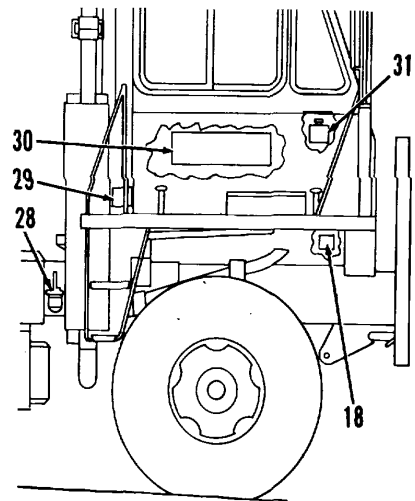
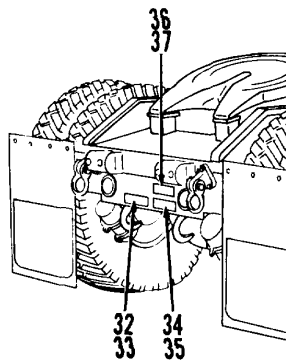
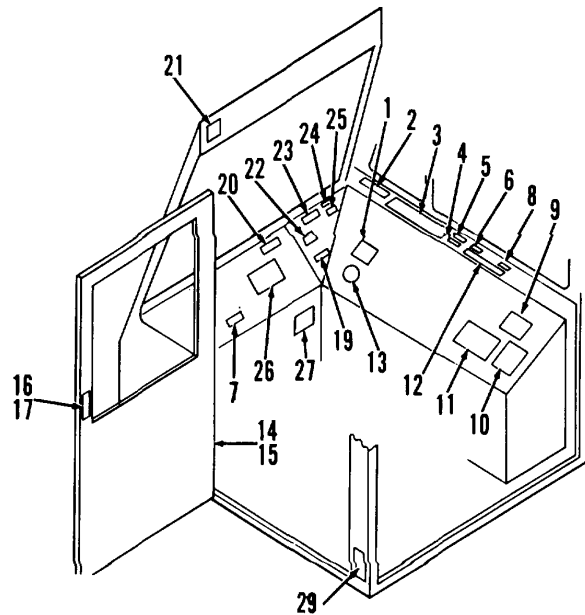

TA236391

2-74. DATA AND INSTRUCTION PLATES MAINTENANCE (CONT)

CAUTION
TO PREVENT SERIOUS INJURY NEVER OPERATE THIS CONTROL, OR ALLOW ANYTHING TO TOUCH IT WHILE TRUCK IS IN MOTION.

DRIVE-TRAIN DATA

TRANSMISSION	ALLISON MT-653
CONVERTER RATIO	ALLISON TC-300 1.88 TO 1
FRONT AXLE	ROCKWELL FF-931 - 12,000 POUNDS
REAR AXLE	ROCKWELL U-240 - 31,500 POUNDS
DIFFERENTIAL RATIO	11.36 TO 1

GW Ottawa Truck Division
Gulf - Western Manufacturing Company

CAUTION
BRAKE TREADLE MUST BE FULLY DEPRESSED WHILE SHIFTING INTO OR OUT OF REVERSE
DO NOT SHUT ENGINE DOWN WHILE SELECTOR IS IN REVERSE

CAUTION

OPERATING INSTRUCTIONS

- WHEN VEHICLE IS TO BE DRIVEN OVER-THE-ROAD FOR AN EXTENDED DISTANCE, HYDRAULIC PUMP P.T.O. SHOULD BE DISENGAGED.
- WHEN CRANKING ENGINE, DO NOT LEAVE STARTER ENGAGED OVER 20 SECONDS. WAIT 1 TO 2 MINUTES BEFORE RE-ENGAGING STARTER FOR ANOTHER 20 SECONDS MAXIMUM CRANKING PERIOD.
- STOP MACHINE BEFORE SHIFTING FROM FORWARD TO REVERSE OR FROM REVERSE TO FORWARD.
- TO COUPLE TO LOW TRAILERS:
 - A - LOWER 5th WHEEL AND DRIVE UNDER TRAILER UNTIL 5th WHEEL PLATE IS JUST COVERED BY TRAILER NOSE.
 - B - RAISE 5th WHEEL APPROX. 5 INCHES.
 - C - FINISH DRIVING UNDER TRAILER UNTIL 5th WHEEL LATCHES.

RUSTPROOFING DATA

Manufacturing of Rustproofing: ASHLAND OIL INC.
Rustproofing Material: ASHLAND 185-E
Rustproofing Performed By: OTTAWA TRUCK DIV
GULF - WESTERN MFG. CO.
Date of Rustproofing:

GW Ottawa Truck Division
Gulf - Western Manufacturing Company

CAUTION
DO NOT TOW VEHICLE OVER 20 MPH, AND NO MORE THAN 15 MILES

TRANS/TORQUE CONVERTER

THIS VEHICLE MEETS SOUND LEVEL REQUIREMENTS AS SPECIFIED IN MIL-STD T-62255C (AT) PARA 3.2.2.1 AND 3.2.3.2

GW Ottawa Truck Division
Gulf - Western Manufacturing Company
Ottawa Truck Division

LUBRICATION CHART

PART	ABOVE 32°F	BELOW 32°F
ENGINE CRANKCASE	MIL-L-2104B/100WMS SUPPLEMENT 1	
	SAE 40	SAE 30
REAR AXLE	MIL-L-2105 B	
	SAE 140	SAE 80W/90
FRONT AXLE	SAE 60W/90	
HYDRAULIC SYSTEM	MIL-N-6808D	
HYDRAULIC POWER STEERING	DEXRON II AUTOMATIC TRANS. FLUID	
TRANSMISSION	DEXRON II AUTOMATIC TRANS. FLUID	
UNIVERSAL JOINTS MISC. CHASSIS FITTINGS	M L G 1 GRADE NO. 3	

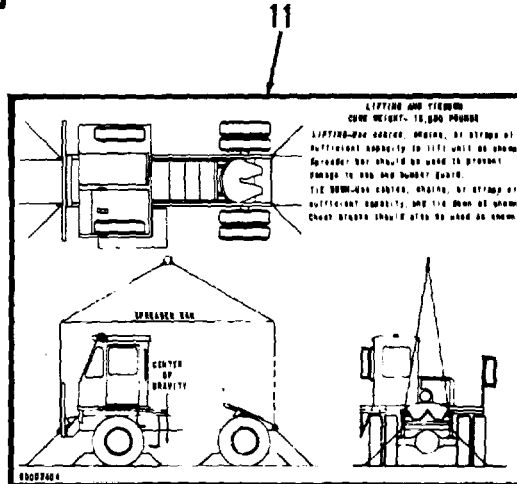

ITEM WARRANTY

As applicable to U.S. Army contract number DAA02-81-C-1133

WARRANTY STATEMENT: Gulf Western Manufacturing Company warrants that the parts and materials used in the manufacture of this equipment shall conform to the specifications of the original manufacturer and shall be free from defects in material and workmanship for a period of 12 months from the date of delivery of the equipment to the user. This warranty does not cover wear and tear, misuse, or damage caused by unauthorized modifications or alterations to the equipment. The user is responsible for the proper maintenance and use of the equipment. This warranty is void if the equipment is used for purposes other than those intended by the manufacturer. For more information, contact the manufacturer.

CAB TILT
MANUAL OPERATING INSTRUCTIONS

TO RAISE CAB:

- ROTATE PUMP LEVER CLOCKWISE AGAINST STOP.
- MANUALLY PUMP WITH JACKHANDLE UNTIL SAFETY BAR DROPS INTO NOTCH.
- ROTATE LEVER COUNTER-CLOCKWISE AGAINST STOP.

TO LOWER CAB:

- ROTATE PUMP LEVER CLOCKWISE AGAINST STOP.
- MANUALLY PUMP WITH JACKHANDLE UNTIL SAFETY BAR CLEARS NOTCH.
- RAISE SAFETY BAR AND ROTATE LEVER COUNTER-CLOCKWISE APPROXIMATELY 1/2 TURN.
- ROTATE LEVER COUNTER-CLOCKWISE AGAINST STOP.

WARNING: STAND CLEAR OF CAB UNTIL SAFETY BAR IS SEATED

2-74. DATA AND INSTRUCTION PLATES MAINTENANCE (CONT)

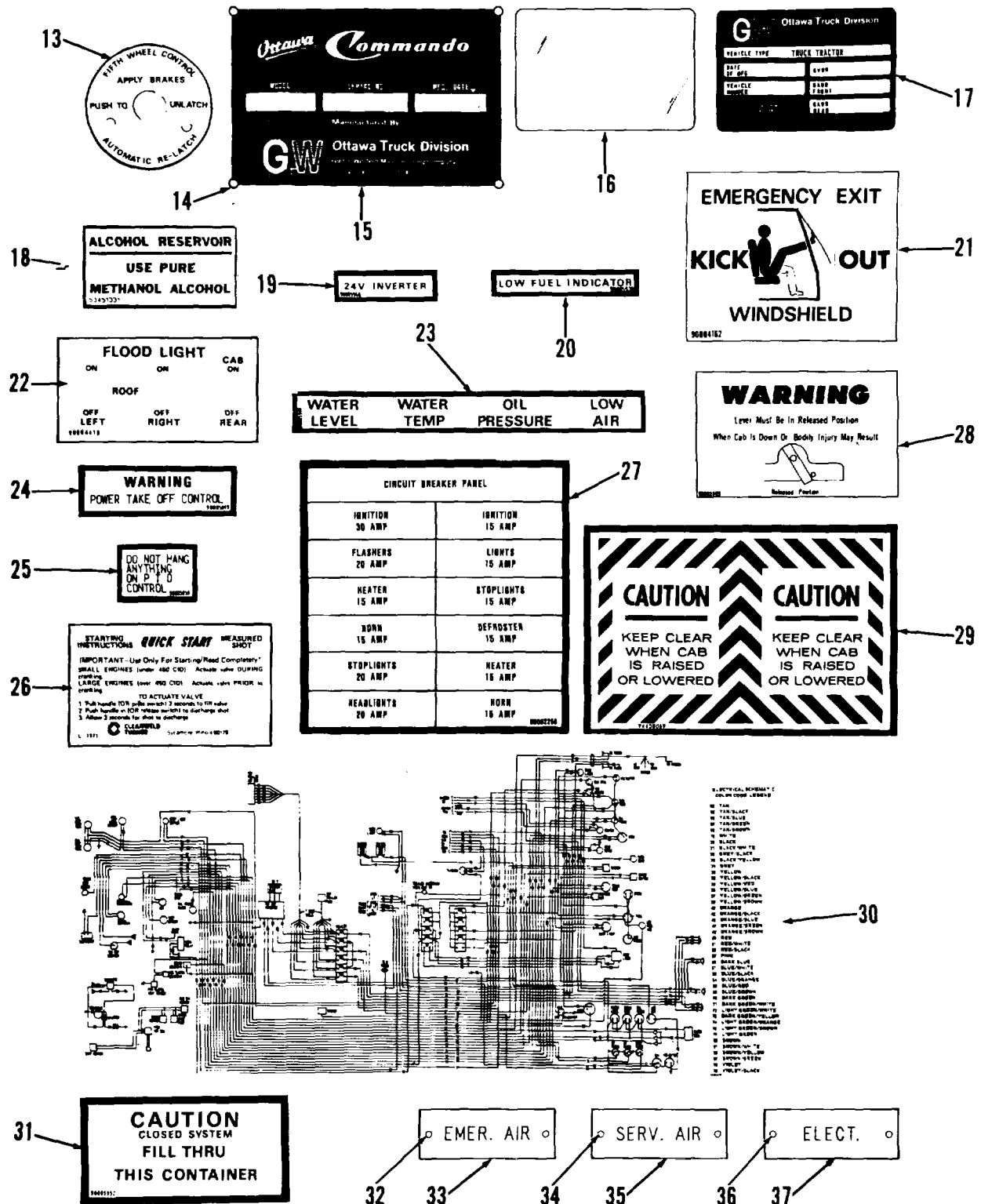

TA236303

Section XI. HYDRAULIC SYSTEMS MAINTENANCE

This section contains the information you need to maintain the:

- Fifth Wheel Hydraulic System
- Cab Tilt Hydraulic System

It gives you instructions on how to troubleshoot problems and repair or replace the components that are within the scope of organizational maintenance.

	Para		Para
Troubleshooting Symptom Index.....	2-75	Hydraulic Filters and Lines and Fittings	2-78b
Fifth Wheel Hydraulic System		Hydraulic Filters.....	2-78b(1)
Troubleshooting	2-76	Lines and Fittings	2-78b(2)
Cab Tilt Hydraulic System		Hydraulic Reservoir	2-78c
Troubleshooting	2-77	Cab Tilt Hydraulic System	
Fifth Wheel Hydraulic System		Maintenance	2-79
Maintenance.....	2-78	Cab Hydraulic Pump.....	2-79a
Fifth Wheel Control Lever and Cable.....	2-78a	Lines and Fittings	2-79b

2-75. TROUBLESHOOTING SYMPTON INDEX

	Para/Malfunction	Page
FIFTH WHEEL HYDRAULIC SYSTEM		
Fifth wheel doesn't lift.....	2-76/1	2-862
Fifth wheel lifts slowly.....	2-76/2	2-863
Fifth wheel creeps downward.....	2-76/3	2-864
Fifth wheel doesn't lower.....	2-76/4	2-865
Hydraulic oil foaming.....	2-76/5	2-865
Excessive hydraulic pump noise	2-76/6	2-865
Hydraulic oil overheating.....	2-76/7	2-866
Hydraulic reservoir overflows.....	2-76/8	2-866
CAB TILT HYDRAULIC SYSTEM		
Cab won't raise to 45 degrees.....	2-77/1	2-867
Cab won't lower or stops part way down.....	2-77/2	2-867
Hydraulic latches lock before cab is all the way down	2-77/3	2-867
Hydraulic latches won't lock.....	2-77/4	2-867

2-76. FIFTH WHEEL HYDRAULIC SYSTEM TROUBLESHOOTING

MALFUNCTION	TEST OR INSPECTION	CORRECTIVE ACTION
--------------------	---------------------------	--------------------------

1. FIFTH WHEEL DOESN'T LIFT

Step 1. Check that engine is running, PTO control is pulled up and power take-off engaged, gear shift control lever is in neutral (N) position, 5th WHEEL control lever is pulled back fully, and load weight does not exceed tractor's 70,000 pound lifting capacity.

- a. If above conditions are not met, refer to TM 9-2320-285-10 for operation of fifth wheel.
- b. If above conditions are met, go to step 2 below.

Step 2. Check if bleed valve is fully closed (valve handle in vertical position).

- a. If bleed valve is open, close it fully.
- b. If bleed valve is fully closed, go to step 3 below.

WARNING

Do not remove filler cap when hydraulic oil is hot. Hot oil can cause severe injury.

Step 3. Remove hydraulic reservoir filler cap and check oil level.

- a. If oil level is below bottom of filter screen, fill with hydraulic oil (para 2-78c) until level is at bottom of filter screen.
- b. If oil level is at bottom of filter screen, go to step 4 below.

WARNING

Do not remove filler cap when hydraulic oil is hot. Hot oil can cause severe injury.

Step 4. Remove hydraulic reservoir filler cap and check for contaminated oil.

- a. If hydraulic oil is contaminated (oil feels gritty, has milky color, is dark and thick, or smells scorched), drain and flush hydraulic system and replace oil filters (para 2-78c and 2-78b(1)).
- b. If hydraulic oil is not contaminated, go to step 5 below.

2-76. FIFTH WHEEL HYDRAULIC SYSTEM TROUBLESHOOTING (CONT)
--

MALFUNCTION	TEST OR INSPECTION	CORRECTIVE ACTION
--------------------	---------------------------	--------------------------

1. FIFTH WHEEL DOESN'T LIFT (Cont)

- Step 5. Check hydraulic pump suction hose for restrictions (blockage, sharp bends). Remove hose if necessary (para 2-78b(2)).

WARNING

Compressed air must not exceed 30 psi. Wear safety glasses when using compressed air. Failure to do so could cause serious injury to eyes and possible blindness. If you hurt your eyes or if a foreign object is blown into your eyes, seek medical aid immediately.

- If hose is blocked, use compressed air (30 psi maximum) to remove blockage; if hose remains blocked, replace (para 2-78b(2)).
- If hose is not blocked, go to step 6 below.

- Step 6. Check all fifth wheel lines, hydraulic control valve, and hydraulic cylinders for visible signs of large oil leaks.

- If large oil leaks are seen, repair as necessary.
- If no large oil leaks are seen or if fifth wheel hydraulic cylinders or hydraulic control valve require repair, notify direct support maintenance.

2. FIFTH WHEEL LIFTS SLOWLY

- Step 1. With vehicle engine idling, raise fifth wheel boom; clock lifting speed. Then lower fifth wheel, accelerate engine to 2000 rpm, and clock lifting speed.

- If lifting speed increases with increase in engine speed, operation is normal.
- If lifting speed does not increase, increases only slightly, or remains slow with increase in engine speed, go to step 2 below.

WARNING

Do not remove filler cap when hydraulic oil is hot. Hot oil can cause severe injury.

2-76. FIFTH WHEEL HYDRAULIC SYSTEM TROUBLESHOOTING (CONT)
--

MALFUNCTION
TEST OR INSPECTION
CORRECTIVE ACTION

2. FIFTH WHEEL LIFTS SLOWLY (Cont)

- Step 2. Remove hydraulic reservoir filler cap and check oil level (para 2-78c).
- If oil level is below bottom of filter screen, fill with hydraulic oil (para 2-78c) until level is at bottom of filter screen.
 - If oil level is at bottom of filter screen, go to step 3 below.
- Step 3. Check for clogged hydraulic filter elements.
- If filter elements are clogged, replace (para 2-78b(1)).
 - If filter elements are not clogged, go to step 4 below.

WARNING

Do not remove filler cap when hydraulic oil is hot. Hot oil can cause severe injury.

- Step 4. Remove hydraulic reservoir filler cap and check for proper viscosity hydraulic oil. (Compare thickness of oil to oil from new container of hydraulic oil.)
- If oil from reservoir is thinner than sample oil, drain and refill hydraulic system and replace oil filters (para 2-78c and 2-78b(1)).
 - If oil from reservoir is same consistency as sample oil, notify direct support maintenance.

3. FIFTH WHEEL CREEPS DOWNWARD

- Step 1. Check if bleed valve is fully closed (handle in vertical position.)
- If bleed valve is open, close it fully.
 - If bleed valve is fully closed, go to step 2 below.
- Step 2. Check all fifth wheel lines, hydraulic control valve, and hydraulic cylinders for visible signs of external leaks.
- If leaks are seen, repair as required.
 - If no leaks are seen, notify direct support maintenance.

2-76. FIFTH WHEEL HYDRAULIC SYSTEM TROUBLESHOOTING (CONT)
--

MALFUNCTION
TEST OR INSPECTION
CORRECTIVE ACTION

4. FIFTH WHEEL DOESN'T LOWER

Try to raise and then slowly lower fifth wheel boom.

- a. If fifth wheel boom lowers, velocity fuses had set (fifth wheel boom was lowered too quickly). Raise and lower fifth wheel boom several times to ensure hydraulic system is functioning properly.
- b. If fifth wheel boom does not lower, notify direct support maintenance.

5. HYDRAULIC OIL FOAMING

Step 1. Check for clogged suction filter element.

- a. If filter element is clogged, replace (para 2-78b(1)).
- b. If filter element is not clogged, go to step 2 below.

Step 2. Check for obstructed hydraulic pump suction hose and fittings.

- a. If suction hose and fittings are obstructed, replace (para 2-78b(1)).
- b. If suction hose and fittings are not obstructed, notify direct support maintenance.

6. EXCESSIVE HYDRAULIC PUMP NOISE

WARNING

Do not remove filler cap when hydraulic oil is hot. Hot oil can cause severe injury.

Remove hydraulic reservoir filler cap and check oil level.

- a. If oil level is below bottom of filter screen, fill with hydraulic oil (para 2-78c) until level is at bottom of filter screen.
- b. If oil level is at bottom of filter screen, refer to Malfunction 5, step 1 above.

2-76. FIFTH WHEEL HYDRAULIC SYSTEM TROUBLESHOOTING (CONT)
--

MALFUNCTION
TEST OR INSPECTION
CORRECTIVE ACTION

7. HYDRAULIC OIL OVERHEATING

WARNING

Do not remove filler cap when hydraulic oil is hot. Hot oil can cause severe injury.

- Step 1. Remove hydraulic reservoir filler cap and check oil level.
- If oil level is below bottom of filter screen, fill with hydraulic oil (para 2-78c) until level is at bottom of filter screen.
 - If oil level is at bottom of filter screen, go to step 2 below.

WARNING

Do not remove filler cap when hydraulic oil is hot. Hot oil can cause severe injury.

- Step 2. Remove hydraulic reservoir filler cap and check for contaminated oil.
- If hydraulic oil is contaminated (oil feels gritty, has milky color, is dark and thick, or smells scorched), drain and flush hydraulic system and replace oil filters (para 2-78c and 2-78b(1)).
 - If hydraulic oil is okay, notify direct support maintenance.

8. HYDRAULIC RESERVOIR OVERFLOWS

WARNING

Do not remove filler cap when hydraulic oil is hot. Hot oil can cause severe injury.

Remove hydraulic reservoir filler cap and check oil level.

- If oil level is above bottom of filter screen and fifth wheel boom is down fully, drain (para 2-78c).
- If oil level is correct, fifth wheel boom was lowered without enough pump speed (air was drawn into top of lift cylinders, causing hydraulic reservoir to overfill). Move fifth wheel boom through several full cycles, then fill reservoir to bottom of filter screen (para 2-78c).

2-77. CAB TILT HYDRAULIC SYSTEM TROUBLESHOOTING
--

MALFUNCTION	TEST OR INSPECTION	CORRECTIVE ACTION
--------------------	---------------------------	--------------------------

1. CAB WON'T RAISE TO 45 DEGREES

Step 1. Check cab tilt hydraulic pump fluid level.

- a. If fluid level is low, fill (para 2-79a).
- b. If fluid level is correct, go to step 2 below.

Step 2. Check cab tilt hydraulic system lines and fittings for visible signs of fluid leaks.

- a. If leaks are found, repair as necessary (para 2-79b).
- b. If no leaks are found, notify direct support maintenance.

2. CAB WON'T LOWER OR STOPS PART WAY DOWN

Raise cab slightly, then try to lower cab slowly.

- a. If cab lowers, cab tilt hydraulic pump velocity fuse had set (cab was lowered too quickly); alternately raise and lower cab to verify proper cab tilt hydraulic system operation. Then return vehicle to normal operation.
- b. If cab does not lower, notify direct support maintenance.

3. HYDRAULIC LATCHES LOCK BEFORE CAB IS ALL THE WAY DOWN

Raise cab enough to allow latch to open fully.

- a. If latch opens fully, lower cab.
- b. If latch does not open fully, notify direct support maintenance.

4. HYDRAULIC LATCHES WON'T LOCK

Check if latches are correctly mounted.

If latches are not correctly mounted, reinstall latches (notify direct support maintenance).

2-78. FIFTH WHEEL HYDRAULIC SYSTEM MAINTENANCE

- a. Fifth Wheel Control Lever and Cable.

This task covers:

- | | | |
|----------------|---------------|-----------------|
| a. Removal | c. Cleaning | e. Reassembly |
| b. Disassembly | d. Inspection | f. Installation |

INITIAL SETUP:

Tools

- No. 1 Common Organizational Maintenance Tool Kit
 - Screwdriver
 - Screwdriver set
 - Torque wrench
 - Key set, socket head capscrew
 - Socket wrench set
 - Puller kit
 - Safety glasses
 - Tool Kit, Electrical Connector
 - Crimping tool
 - Wire stripper
- Automotive Mechanic's Tool Kit
 - Pliers
- Soft mallet

- Tags Item 14, Appendix C
- Grease Item 26, Appendix C
- Cotter pin FSCM 90915 PN 90831050
- Six tie straps FSCM 96906 PN MS3667-2-9
- Electrical connector FSCM 77060 PN 2965867

Personnel Required

Wheel Vehicle Mechanic MOS 63B

Equipment Condition

Paragraph	Condition Description
-----------	-----------------------

Vehicle parked on level surface, engine off, and parking brake applied. Cab tilted 45 degrees. Rear platform removed. Heat shield removed.

Materials/Parts

- | | | |
|--------------|--------------------|-------|
| Cleaning | | 2-65c |
| Solvent | Item 1, Appendix C | 2-65d |
| Clean cloths | Item 2, Appendix C | |

KEY

- | | | |
|----------------|-------------------------------|----------------------------|
| 1. Cotter pin | 16. Nuts (4) | 30. Nut plate |
| 2. Clevis pin | 17. Lock washers (4) | 31. Hanger plate |
| 3. Clevis | 18. Screws (4) | 32. Rear housing |
| 4. Nut | 19. Clip nuts (2) | 33. Nut |
| 5. Clamp | 20. Label | 34. Nuts (2) |
| 6. Setscrew | 21. Lamps (2) | 35. Washers (2) |
| 7. Pivot | 22. Socket assemblies (2) | 36. Connector housing |
| 8. Nuts (2) | 23. Locknuts (2) | 37. Electrical connector |
| 9. Screws (2) | 24. Socket head capscrews (2) | 38. Tie straps (2) |
| 10. Clamp | 25. Plain housing | 39. Tie strap |
| 11. Spacer | 26. Clips (2) | 40. Tie straps (3) |
| 12. Cable | 27. Lever | 41. Protective hose |
| 13. Knob | 28. Bushings (2) | 42. Electrical leads (BLU) |
| 14. Screws (4) | 29. Screws (2) | 43. Tie strap |
| 15. Cover | | |

2-78. FIFTH WHEEL HYDRAULIC SYSTEM MAINTENANCE (CONT)

a. Fifth Wheel Control Lever and Cable (cont).

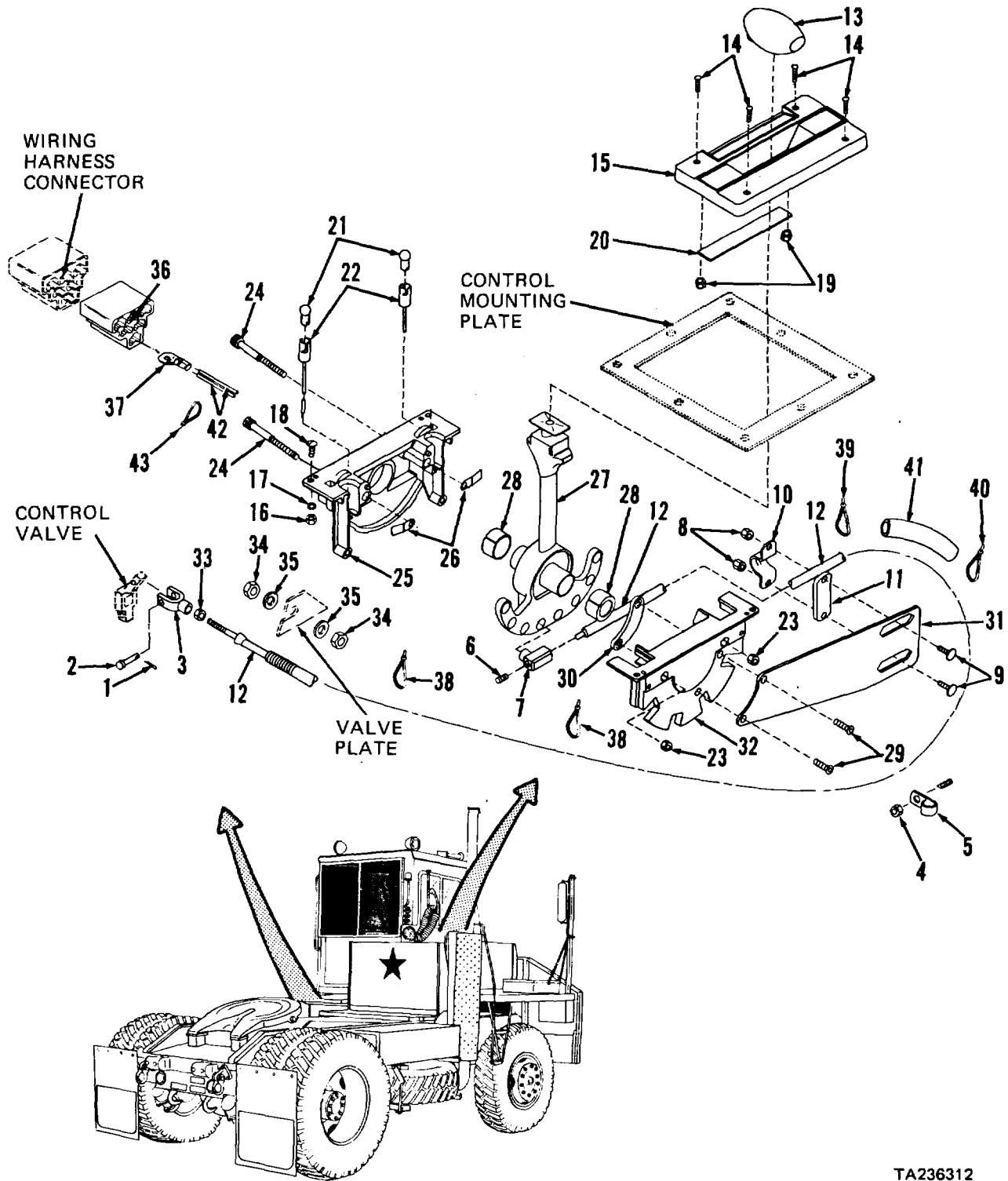

TA236312

2-78. FIFTH WHEEL HYDRAULIC SYSTEM MAINTENANCE (CONT)

a. Fifth Wheel Control Lever and Cable (cont).

STEP	LOCATION	ITEM	ACTION	REMARKS
REMOVAL				
1	Control valve, left hand frame rail	a. Cotter pin (1)	Remove and discard	
		b. Clevis pin (2)	Remove	
		c. Nut (33)	Loosen	
		d. Clevis (3) and nut (33)	Remove	From cable (12)
		e. Two nuts (34)	Loosen	
		f. Cable (12)	Disconnect	Slide from valve plate
		g. Two nuts (34) and washers (35)	Remove	From cable (12)
2	Left hand frame rail	Two tie straps (38)	Cut, remove, and discard	Note locations for installation
3	Cab, underside	a. Three tie straps (40)	Cut, remove, and discard	From protective hose (41); note locations for installation
		b. Protective hose (41)	Remove	From fifth wheel and gear shift cables
		c. Nut (4) and clamp (5)	Remove	
		d. Tie straps (39 and 43)	Cut, remove, and discard	Note locations for installation
		e. Two nuts (8), screws (9), clamp (10), and spacer (11)	Remove	
		f. Two screws (29)	Loosen	
		g. Lever (27) and cable (12)	Move	Use movement to disengage pivot (7) from lever and move through slot in side of housing (32)
		h. Setscrew (6)	Loosen	Remove only if necessary for replacement of pivot (7) or cable (12)
		i. Pivot (7)	Remove	From cable (12)
		j. Cable (12)	Remove	From tractor

2-78. FIFTH WHEEL HYDRAULIC SYSTEM MAINTENANCE (CONT)

a. Fifth Wheel Control Lever and Cable (cont).

STEP	LOCATION	ITEM	ACTION	REMARKS
REMOVAL (cont)				
4	Cab interior	a. Knob (13)	Remove	
		b. Four screws (14), cover (15), label (20), and two clip nuts (19)	Remove	
		c. Connector housing (36)	Disconnect	Unplug from wiring harness connector
		d. Electrical connector (37)	a. Disconnect	Pull two electrical leads (42) with connector (37) from connector housing (36)
			b. Remove and discard	Only if inspection indicates need for replacement. Cut two leads as close to connector as possible
		e. Four nuts (16), lock washers (17), and screws (18)	Remove (18)	Have assistant hold screws
		f. Fifth wheel control assembly	Remove	Lift out through opening in control mounting plate

DISASSEMBLY

5	Rear housing (32)	a. Two locknuts (23) and socket head cap-screws (24)	Remove	
		b. Housings (25 and 32)	Separate	
		c. Two clips (26)	Remove	
		d. Lever (27)	Remove	
		e. Two bushings (28)	Remove	Use puller, suitable sleeve, and soft mallet only if replacement is required
		f. Two screws (29) and nut plate (30)	Remove	
		g. Hanger plate (31)	Remove	Note position for reassembly; then separate from rear housing (32)

2-78. FIFTH WHEEL HYDRAULIC SYSTEM MAINTENANCE (CONT)

a. Fifth Wheel Control Lever and Cable (cont).

STEP	LOCATION	ITEM	ACTION	REMARKS
DISASSEMBLY (cont)				
6	Plain housing (25)	a. Two lamps (21) b. Two socket assemblies (22) with electrical leads (42)	Remove Remove	

CLEANING

7		a. Cable (12), knob (13), cover (15), two lamps (21), socket assemblies (22) and leads (42)	Clean	Wipe with clean, dry cloth
---	--	---	-------	----------------------------

WARNING

Dry cleaning solvent (P-D-680), used to clean parts is toxic and flammable. Wear protective goggles and gloves and use only in a well ventilated area. Avoid contact with skin, eyes, and clothes and don't breathe vapors. Do not use near open flame or excessive heat and don't smoke when using it. Failure to do so could cause serious injury. If you become dizzy while using cleaning solvent, get fresh air and medical attention immediately. If contact with skin or clothes is made, flush with large amounts of water. If contact with eyes is made, wash eyes with water and seek medical aid immediately.

Compressed air must not exceed 30 psi. Wear safety glasses when drying parts with compressed air. Failure to do so could cause serious injury to eyes and possible blindness. If you hurt your eyes or if a foreign object is blown into your eyes, seek medical attention immediately.

b. All other parts	Clean	Use cleaning solvent P-D-680; dry using compressed air
--------------------	-------	--

2-78. FIFTH WHEEL HYDRAULIC SYSTEM MAINTENANCE (CONT)
--

a. Fifth Wheel Control Lever and Cable (cont).

STEP	LOCATION	ITEM	ACTION	REMARKS
INSPECTION				
8		a. Cable (12)	Inspect	Replace if cracked, broken, kinked, or otherwise damaged
		b. Label (20)	Inspect	Replace if damaged or illegible
		c. Lamps (21)	Inspect	Replace if filaments or glass broken
		d. Electrical leads (42)	Inspect	Replace with socket assembly (22) if insulation frayed, cut, or cracked or if conductor corroded or broken
		e. Lever (27)	Inspect	Replace if cracked, broken, distorted, or holes for pivot (7) out-of-round
		f. Rear housing (32)	Inspect	Replace if cracked, broken, distorted, or detents worn
		g. All other parts	Inspect	Replace if cracked, broken, worn, or threads damaged
REASSEMBLY				
9	Rear housing (32)	a. Hanger plate (31)	Position	On rear housing (32) at location noted during disassembly
		b. Nut plate (30) and two screws (29)	Install	Do not tighten screws
		c. Two bushings (28)	Install	Press on housings (25 and 32)
		d. Lever (27)	Position	In rear housing (32)
		e. Two socket assemblies (22) and lamps (21)	Install	
		f. Two clips (26)	Position	On plain housing (25)
		g. Plain housing (25) and rear housing (32)	Mate	
		h. Two socket head capscrews (24) and locknuts (23)	Install	
		i. Label (20)	Position	In cover (15)
		j. Two clip nuts (19)	Install	

2-78. FIFTH WHEEL HYDRAULIC SYSTEM MAINTENANCE (CONT)
--

a. Fifth Wheel Control Lever and Cable (cont).

STEP	LOCATION	ITEM	ACTION	REMARKS
INSTALLATION				
10	Cab, interior	a. Fifth wheel control assembly	Install	Through opening in control mounting plate
		b. New electrical connector (37)	a. Install, if necessary b. Connect	Strip 1/2-inch insulation from two leads (42), twist leads together, and crimp to connector securely Push connector with two leads into connector housing (36)
		c. Four screws (18), lock washers (17), and nuts (16)	Install	Have assistant hold screws (18)
		d. Cover (15)	Position	
		e. Four screws (14)	Install	Tighten to 10 pounds inch torque
		f. Knob (13)	Install	
11	Tractor cab, underside	a. Cable (12)	Position	
		b. Pivot (7)	Install	On cable (12), if removed
		c. Setscrew (6)	Install, if removed	Tighten to 33 pounds inch torque
		d. Cable (12)	Lubricate	Lubricate both ends with grease
		e. Fifth wheel control lever (27) and cable (12)	Move	Use movement to engage pivot (7) through slot in side of housing (32) and into correct lever hole
		f. Two screws (29)	Tighten	To 90 pounds inch torque
		g. Two screws (9)	Install	Through hanger plate (31) so that screw (9) centers are at line "6" on hanger plate
		h. Spacer (11)	Position	On screws (9)
		i. Clamp (10)	Install	Around cable (12) and on screws (9)
		j. Two nuts (8)	Install and tighten	
		k. New tie strap (39)	Install	On cable (12) at location noted during removal
l. Protective hose (41) and three new tie straps (40)	Install	At location noted during removal		

2-78. FIFTH WHEEL HYDRAULIC SYSTEM MAINTENANCE (CONT)
--

- a. Fifth Wheel Control Lever and Cable (cont).

STEP	LOCATION	ITEM	ACTION	REMARKS
INSTALLATION (cont)				
11 (cont)		m. Clamp (5) and nut (4)	Install	Tighten nut (4)
		n. Connector housing (36)	Connect	Push into wiring harness connector
		o. New tie strap (43)	Install	On leads (42) at location noted during removal
12	Left hand frame rail	a. Cable (12)	Route	
		b. Two new tie straps (38)	Install	At locations noted during removal
		c. Heat shield	Install	Para 2-65d
13	Control valve	a. Two nuts (34) and washers (35)	Install	On cable (12)
		b. Cable (12)	Position	Slide into valve plate slot
		c. Two nuts (34)	Adjust and tighten	
		d. Nut (33) and clevis (3)	Install	On cable (12)
14	Cab tilt pump	Cab	Lower	To normal operating position
15	Control valve, left hand frame rail	a. Fifth wheel control lever (27)	Position	In neutral (N) position
		b. Clevis (3)	Position	At top of control valve lever with holes aligned
		c. Clevis pin (2) and new cotter pin (1)	Install; spread cotter pin	
		d. Nut (33)	Tighten	
16	Tractor cab	a. Key switch	Turn on	
		b. Fifth wheel operation	Check	Check for proper operation
		c. Key switch	Turn off	
17	Tractor frame	Rear platform	Install	Para 2-65c

2-78. FIFTH WHEEL HYDRAULIC SYSTEM MAINTENANCE (CONT)

b. Hydraulic Filters and Lines and Fittings.

(1) Hydraulic Filters.

This task covers:

- a. Servicing
- b. Removal
- c. Disassembly
- d. Cleaning
- e. Inspection
- f. Reassembly
- g. Installation

INITIAL SETUP:

Tools

No. 1 Common Organizational Maintenance Tool Kit	Element, suction line filter	FSCM 97576 PN CP1002-10
Socket wrench set		
Socket head screw key set	<u>Personnel Required</u>	
Oil filter removal tool	Wheel Vehicle Mechanic MOS 63B	
Spring replacement tool		

Materials/Parts

Clean cloths	Item 2, Appendix C	
Hydraulic oil	Item 22, Appendix C	
Thread sealant	Item 29, Appendix C	
Element, return line filter	FSCM 02249 PN K-22002	
	<u>Equipment Condition</u>	Condition Description
	Paragraph	Vehicle parked on level surface, engine off, and parking brake applied.

STEP	LOCATION	ITEM	ACTION	REMARKS
------	----------	------	--------	---------

SERVICING

WARNING

Push operator's 5th wheel lever forward to lower 5th wheel and relieve hydraulic pressure before proceeding. Failure to follow this procedure could result in severe injury. If you are injured, seek medical help immediately.

1	Cab	5th WHEEL lever	Push forward	To ensure that all pressure is relieved
2	Left hand frame rail	a. Hydraulic reservoir	Drain	Para 2-78c
		b. Return line filter element	Remove and discard	Use oil filter tool; rotate counterclockwise
		c. Suction line filter element	Remove and discard	Use oil filter tool; rotate counterclockwise

2-78. FIFTH WHEEL HYDRAULIC SYSTEM MAINTENANCE (CONT)

b. Hydraulic Filters and Lines and Fittings (cont).

(1) Hydraulic Filters (cont).

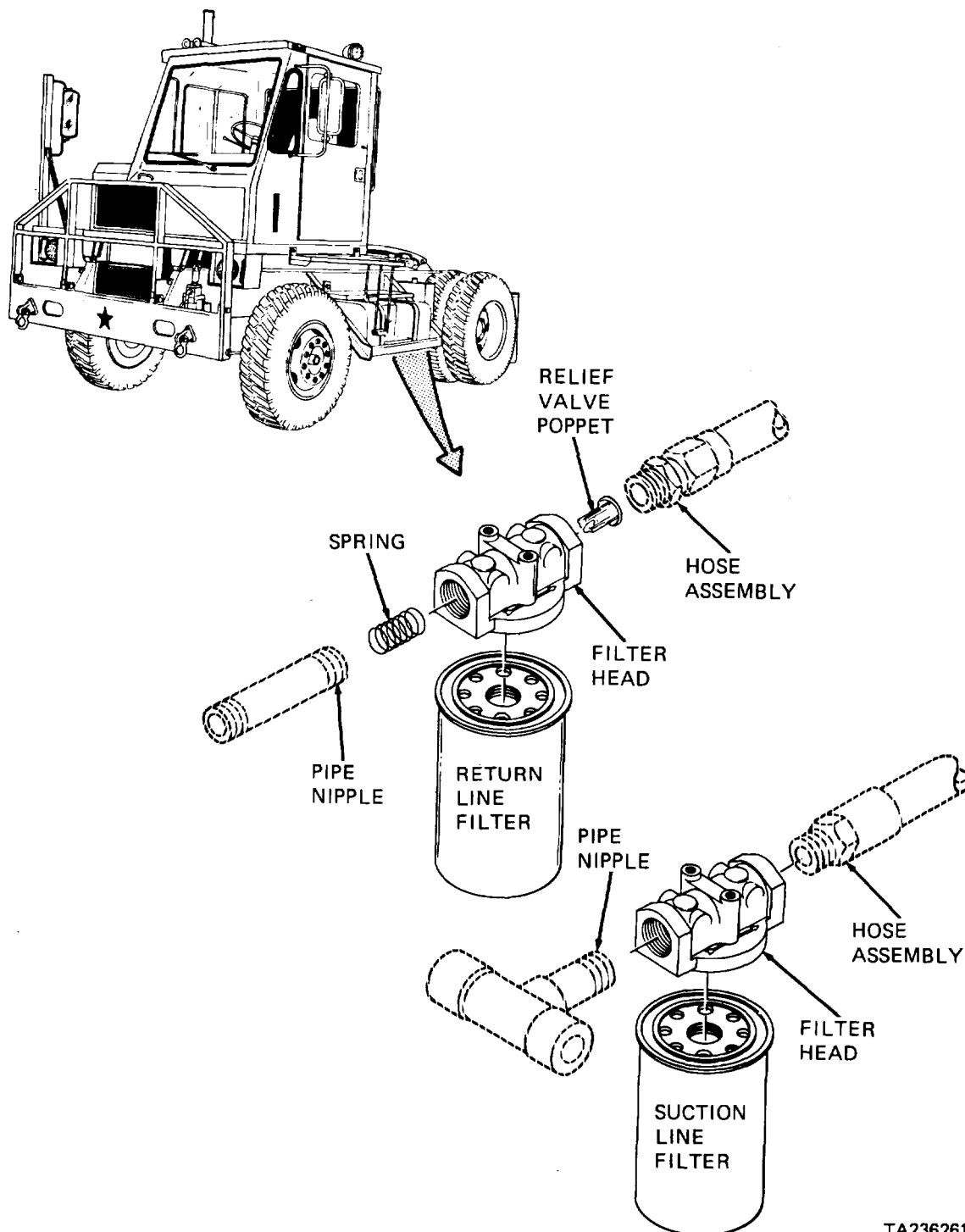

TA236261

2-78. FIFTH WHEEL HYDRAULIC SYSTEM MAINTENANCE (CONT)

b. Hydraulic Filters and Lines and Fittings (cont).

(1) Hydraulic Filters (cont).

STEP	LOCATION	ITEM	ACTION	REMARKS
SERVICING (cont)				
2 (cont)		d. New suction line filter element	a. Coat gasket b. Install	Apply thin film of clean hydraulic oil Hand tighten approximately one turn
		e. New return line filter element	a. Coat gasket b. Install	Apply thin film of clean hydraulic oil Hand tighten approximately one turn
		f. Hydraulic reservoir	Fill	Para 2-78c
REMOVAL				
3	Cab	5th WHEEL lever	Push forward	To ensure that all pressure is relieved
4	Left hand frame rail	a. Hydraulic reservoir	Drain	Para 2-78c
		b. Return line filter element	Remove and discard	Use oil filter tool; rotate counterclockwise
		c. Hose assembly	Disconnect	From return line filter head; para 2-78b(2)
		d. Suction line filter element	Remove and discard	Use oil filter tool; rotate counterclockwise
		e. Hose assembly	Disconnect	From suction line filter head; para 2-78b(2)
		f. Suction line filter head	Unscrew	From nipple
		g. Hydraulic reservoir	Remove	Only if necessary to remove return line filter head; para 2-78c
5	Hydraulic reservoir	Return line filter head	Unscrew	From nipple

2-78. FIFTH WHEEL HYDRAULIC SYSTEM MAINTENANCE (CONT)

b. Hydraulic Filters and Lines and Fittings (cont).

(1) Hydraulic Filters (cont).

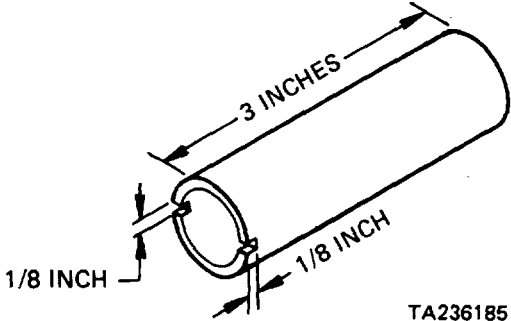
STEP	LOCATION	ITEM	ACTION	REMARKS
DISASSEMBLY				
6	Spring replacement tool	Spring replacement tool	Fabricate, if necessary	Cut a section of 3/4-inch O.D., 5/8-inch I.D. electric conduit 3 inches long. Cut two notches, 1/8-inch wide by 1/8-inch deep in one end of conduit as shown
 <p style="text-align: right;">TA236185</p>				
7	Return line filter head	a. Relief valve poppet	Secure	Insert allen wrench into outlet port of filter head and into relief valve poppet to hold poppet in place
		b. Spring replacement tool	Insert	Into inlet port of filter head
		c. Spring	a. Hold	Use notches of spring replacement tool to secure spring
			b. Depress and turn	Turn clockwise
		d. Spring replacement tool	Remove	From return line filter head
		e. Spring and relief valve poppet		

2-78. FIFTH WHEEL HYDRAULIC SYSTEM MAINTENANCE (CONT)

b. Hydraulic Filters and Lines and Fittings (cont).

(1) Hydraulic Filters (cont).

STEP	LOCATION	ITEM	ACTION	REMARKS
CLEANING				
WARNING				
<p>Dry cleaning solvent (P-D-680), used to clean parts is toxic and flammable. Wear protective goggles and gloves and use only in a well ventilated area. Avoid contact with skin, eyes, and clothes and don't breathe vapors. Do not use near open flame or excessive heat and don't smoke when using it. Failure to do so could cause serious injury. If you become dizzy while using cleaning solvent, get fresh air and medical attention immediately. If contact with skin or clothes is made, flush with large amounts of water. If contact with eyes is made, wash eyes with water and seek medical aid immediately.</p> <p>Compressed air must not exceed 30 psi. Wear safety glasses when drying parts with compressed air. Failure to do so could cause serious injury to eyes and possible blindness. If you hurt your eyes or if a foreign object is blown into your eyes, seek medical attention immediately.</p>				
8		All parts	Clean	Use cleaning solvent P-D-680; dry using compressed air
INSPECTION				
9		a. Spring	Inspect	Replace if coils broken, weak, or permanently set
		b. All other parts	Inspect	Replace if cracked, worn, corroded, distorted, or threads damaged
REASSEMBLY				
10	Return line filter head	a. Filter head	Coat	Lightly coat with clean hydraulic oil on all parts of filter head

2-78. FIFTH WHEEL HYDRAULIC SYSTEM MAINTENANCE (CONT)

b. Hydraulic Filters and Lines and Fittings (cont).

(1) Hydraulic Filters (cont).

STEP	LOCATION	ITEM	ACTION	REMARKS
REASSEMBLY (cont)				
10 (cont)			<u>CAUTION</u>	
			When replacing relief valve poppet and spring, be sure that poppet is installed from outlet side of filter head, and that spring is installed from inlet side of filter head.	
		b. Relief valve poppet	a. Install head b. Secure	Into outlet side of filter Insert allen wrench into outlet port of filter head to hold poppet in place
		c. Spring	Install	Into inlet side of filter head
		d. Spring replacement tool	a. Insert b. Depress and turn c. Remove	Insert notches of tool over spring Turn counterclockwise to install spring
11	Suction line filter head	Filter head	Coat	Lightly coat with clean hydraulic oil on all parts of filter head

INSTALLATION

NOTE

Perform step 12 below only if return line filter head was removed.

12	Hydraulic reservoir	a. Pipe nipple	Coat threads	Use thread sealant
----	---------------------	----------------	--------------	--------------------

NOTE

Be sure to install spring end of return line filter head on nipple.

		b. Return line filter head	Install	On nipple
--	--	----------------------------	---------	-----------

2-78. FIFTH WHEEL HYDRAULIC SYSTEM MAINTENANCE (CONT)

b. Hydraulic Filters and Lines and Fittings (cont).

(1) Hydraulic Filters (cont).

STEP	LOCATION	ITEM	ACTION	REMARKS
INSTALLATION (cont)				
13	Left hand frame rail	a. Hydraulic reservoir	Install	If removed, para 2-78c
		b. Pipe nipple	Coat threads	Use thread sealant
		c. Hose assembly	Connect	To return line filter head; para 2-78b(2)

CAUTION

Be sure to install suction line filter head so oil flows in direction of arrow on filter head.

		d. Suction line filter head	Install	On nipple
		e. Hose assembly	Connect	To suction line filter head; para 2-78b(2)
		f. Filter elements	a. Coat	Lightly coat gasket with clean hydraulic oil
			b. Install	On filter head. Hand tighten one turn
		g. Hydraulic reservoir	Fill	Para 2-78c
		h. Filter heads	Inspect	Check for oil leaks

2-78. FIFTH WHEEL HYDRAULIC SYSTEM MAINTENANCE (CONT)

b. Hydraulic Filter and Lines and Fittings (cont).

(2) Lines and Fittings.

This task covers: a. Removal c. Inspection
 b. Cleaning d. Installation

INITIAL SETUP

Tools

No. 1 Common Organizational Maintenance

Tool Kit

- Adjustable open end wrench
- Socket wrench set
- Combination wrench set
- Socket head screw key set
- Safety glasses

Materials/Parts

Cleaning

- solvent Item 1, Appendix C
- Clean cloths Item 2, Appendix C
- Tags Item 14, Appendix C
- Hydraulic oil Item 22, Appendix C
- Tie straps FSCM 96906 PN MS3667-2-9

Personnel Required

Two Wheel Vehicle Mechanics MOS 63B

Equipment Condition

Paragraph	Condition Description
	Vehicle parked on level surface, engine off, and parking brake applied.
2-65c	Rear platform removed.
2-78c	Hydraulic reservoir drained.
2-78b(1)	Hydraulic filter elements removed.

STEP	LOCATION	ITEM	ACTION	REMARKS
------	----------	------	--------	---------

REMOVAL

NOTE

Tag all hose assemblies before disconnecting and removing. Do not remove fittings from hoses. Remove hose and attached fittings as an assembly. Cut, remove, and discard all tie straps and remove all clamps as necessary to remove hose assemblies. Note locations to aid installation.

1	Control valve	a. Elbow (1)	Loosen nut	
		b. Hose assembly (4)	Disconnect fitting	From elbow (1)
		c. Elbow (2)	Loosen nut	
		d. Hose assembly (21)	Disconnect fitting	From elbow (2)
		e. Elbow (3)	Loosen nut	
		f. Hose assembly (22)	Disconnect fitting	From elbow (3)

2-78. FIFTH WHEEL HYDRAULIC SYSTEM MAINTENANCE (CONT)

b. Hydraulic Filter and Lines and Fittings (cont).

(2) Lines and Fittings (cont).

KEY

- 1. Elbow
- 2. Elbow
- 3. Elbow
- 4. Hose assembly
- 5. Elbow
- 6. Elbow
- 7. Hose assembly
- 8. Hose assembly
- 9. Nipple
- 10. Elbow
- 11. Elbow
- 12. Adapter
- 13. Handle and screw

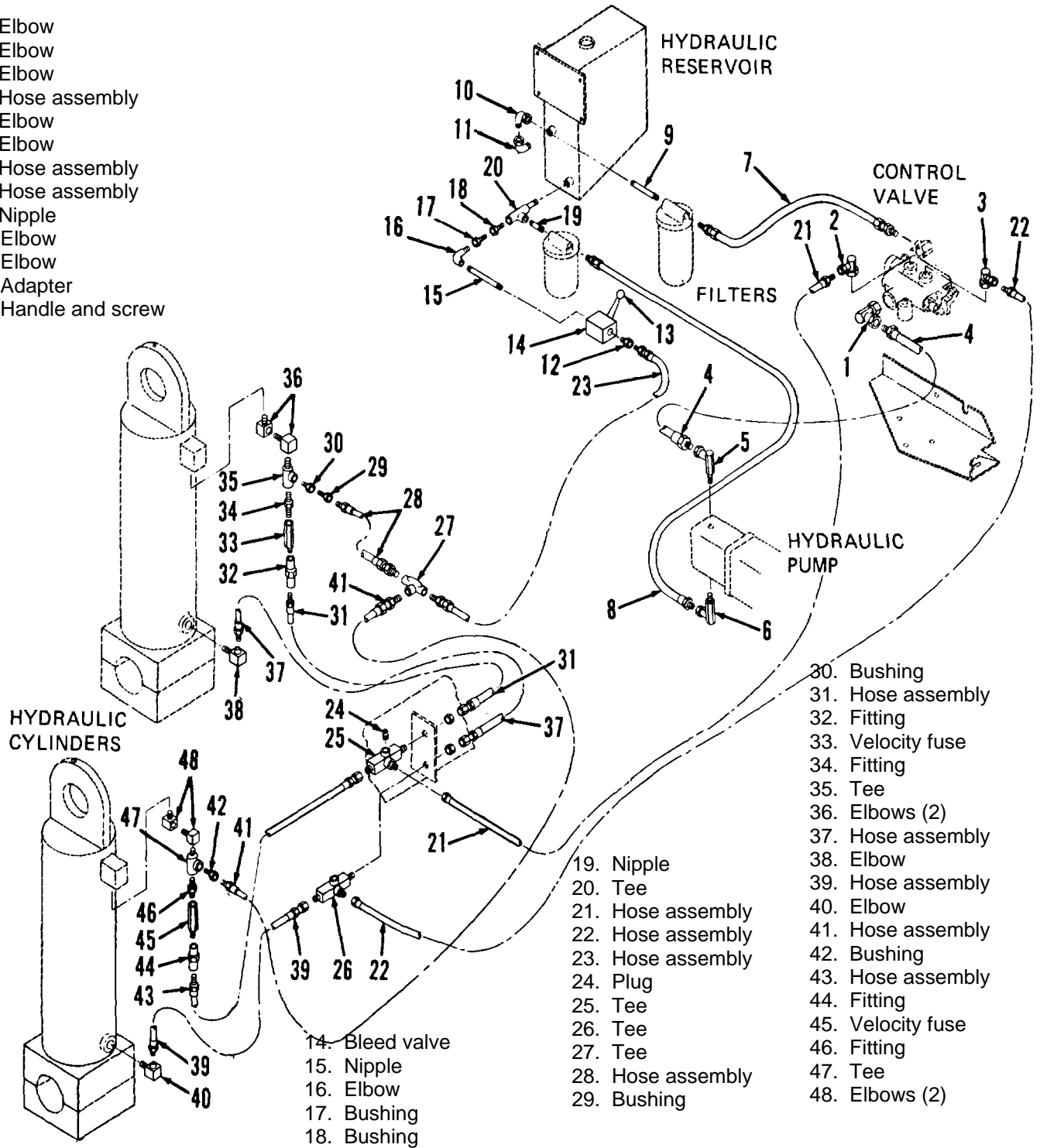

- 30. Bushing
- 31. Hose assembly
- 32. Fitting
- 33. Velocity fuse
- 34. Fitting
- 35. Tee
- 36. Elbows (2)
- 37. Hose assembly
- 38. Elbow
- 39. Hose assembly
- 40. Elbow
- 41. Hose assembly
- 42. Bushing
- 43. Hose assembly
- 44. Fitting
- 45. Velocity fuse
- 46. Fitting
- 47. Tee
- 48. Elbows (2)

- 14. Bleed valve
- 15. Nipple
- 16. Elbow
- 17. Bushing
- 18. Bushing

2-78. FIFTH WHEEL HYDRAULIC SYSTEM MAINTENANCE (CONT)

b. Hydraulic Filter and Lines and Fittings (cont).

(2) Lines and Fittings (cont).

STEP	LOCATION	ITEM	ACTION	REMARKS
REMOVAL (cont)				
1 (cont)		g. Hydraulic control valve elbow	Loosen nut	
		h. Hose assembly (7)	Disconnect fitting	From elbow
		i. Three elbows (1 thru 3)	a. Loosen nut b. Remove	Loosen O-ring locknut From hydraulic control valve
2	Hydraulic pump	a. Hose assembly (4)	a. Disconnect fitting b. Remove	From elbow (5) From tractor
		b. Elbow (5)	Remove	From hydraulic pump
		c. Elbow (6)	Loosen nut	
		d. Hose assembly (8)	Disconnect fitting	From elbow (6)
		e. Elbow (6)	Remove	From hydraulic pump
3	Left hand frame rail	a. Hose assembly (7)	a. Disconnect fitting b. Remove	From return line filter head From tractor
		b. Hose assembly (8)	a. Loosen nut b. Disconnect fitting c. Remove	From suction line filter head From tractor
4	Hydraulic reservoir	a. Suction line filter head	Remove	From nipple (19); para 2-78b(1)
		b. Hose assembly (23)	a. Loosen nut b. Disconnect fitting	From adapter (12)
		c. Adapter (12)	Remove	From bleed valve (14)
		d. Handle and screw (13)	Remove	From bleed valve (14)
		e. Bleed valve (14)	Remove	From nipple (15)
		f. Nipple (15), elbow (16), and two bushings (17 and 18)	Remove	
		g. Nipple (19)	Remove	From tee (20)
		h. Tee (20)	Remove	From hydraulic reservoir

2-78. FIFTH WHEEL HYDRAULIC SYSTEM MAINTENANCE (CONT)

b. Hydraulic Filter and Lines and Fittings (cont).

(2) Lines and Fittings (cont).

STEP	LOCATION	ITEM	ACTION	REMARKS
REMOVAL (cont)				
4 (cont)		i. Hydraulic reservoir	Remove	Para 2-78c
		j. Return line filter head	Remove	From nipple (9); para 2-78b(1)
		k. Nipple (9) and elbows (10 and 11)	Remove	From hydraulic reservoir
5	Fifth wheel boom cross-member, rear	a. Hose assembly (21)	a. Disconnect fitting b. Remove	From tee (25) From tractor
		b. Hose assembly (22)	a. Disconnect fitting b. Remove	From tee (26) From tractor
		c. Hose assembly (23)	a. Disconnect fitting b. Remove	From tee (27) From tractor
		d. Hose assembly (43)	a. Loosen nut b. Disconnect fitting	From tee (25)
		e. Hose assembly (39)	a. Loosen nut b. Disconnect fitting	From tee (26)
		f. Hose assembly (31)	a. Loosen nut b. Disconnect fitting	From tee (25)
		g. Hose assembly (37)	a. Loosen nut b. Disconnect fitting	From tee (26)
		h. Plug (24)	Remove	From tee (25)
		i. Tee (25)	Remove	Remove nut and pull tee from fifth wheel boom cross-member projecting wall
		j. Tee (26)	Remove	Remove nut and pull tee from fifth wheel boom cross-member projecting wall
		k. Hose assembly (41)	Disconnect fitting	From tee (27)
		l. Tee (27)	Remove	From hose (28)

2-78. FIFTH WHEEL HYDRAULIC SYSTEM MAINTENANCE (CONT)

b. Hydraulic Filter and Lines and Fittings (cont).

(2) Lines and Fittings (cont).

STEP	LOCATION	ITEM	ACTION	REMARKS
REMOVAL (cont)				
6	Left hand hydraulic cylinder	a. Hose assembly (28)	a. Loosen nut b. Disconnect fitting c. Remove	From bushing (29) From tractor
		b. Bushing (29)	Remove	From bushing (30)
		c. Bushing (30)	Remove	From tee (35)
		d. Hose assembly (31)	a. Disconnect fitting b. Remove	From fitting (32) From tractor
		e. Fitting (32)	Remove	From velocity fuse (33)
		f. Velocity fuse (33)	Remove	From fitting (34)
		g. Fitting (34)	Remove	From tee (35)
		h. Tee (35)	Remove	From elbow (36)
		i. Two elbows (36) cylinder	Remove	From left hand hydraulic
		j. Hose assembly (37)	a. Disconnect fitting b. Remove	From elbow (38) From tractor
		k. Elbow (38)	Remove	From left hand hydraulic cylinder
7	Right hand hydraulic cylinder	a. Hose assembly (39)	a. Disconnect fitting b. Remove	From elbow (40) From tractor
		b. Elbow (40)	Remove	From right hand hydraulic cylinder
		c. Hose assembly (41)	a. Disconnect fitting b. Remove	From bushing (42) From tractor
		d. Bushing (42)	Remove	From tee (47)
		e. Hose assembly (43)	a. Disconnect fitting b. Remove	From fitting (44) From tractor
		f. Fitting (44)	Remove	From velocity fuse (45)
		g. Velocity fuse (45)	Remove	From fitting (46)
		h. Fitting (46)	Remove	From tee (47)
		i. Tee (47)	Remove	From elbow (48)
		j. Two elbows (48)	Remove	From right hand hydraulic cylinder

2-78. FIFTH WHEEL HYDRAULIC SYSTEM MAINTENANCE (CONT)

b. Hydraulic Filter and Lines and Fittings (cont).

(2) Lines and Fittings (cont).

STEP	LOCATION	ITEM	ACTION	REMARKS
CLEANING 8		a. All hoses	Clean	Use clean cloth moistened with clean hydraulic oil

WARNING

Dry cleaning solvent (P-D-680), used to clean parts is toxic and flammable. Wear protective goggles and gloves and use only in a well ventilated area. Avoid contact with skin, eyes, and clothes and don't breathe vapors. Do not use near open flame or excessive heat and don't smoke when using it. Failure to do so could cause serious injury. If you become dizzy while using cleaning solvent, get fresh air and medical attention immediately. If contact with skin or clothes is made, flush with large amounts of water. If contact with eyes is made, wash eyes with water and seek medical aid immediately.

Compressed air must not exceed 30 psi. Wear safety glasses when drying parts with compressed air. Failure to do so could cause serious injury to eyes and possible blindness. If you hurt your eyes or if a foreign object is blown into your eyes, seek medical attention immediately.

		b. All other parts	Clean	Use cleaning solvent P-D-680; dry with compressed air or clean cloths
INSPECTION 9		a. Velocity fuses (33 and 45) and bleed valve (14)	Inspect	Replace if cracked, inoperative, or threads damaged
		b. All hose assemblies	Inspect	Replace if cracked, worn, chafed, broken, or threads damaged
		c. All other parts	Inspect	Replace if cracked, split, or threads damaged

2-78. FIFTH WHEEL HYDRAULIC SYSTEM MAINTENANCE (CONT)

b. Hydraulic Filter and Lines and Fittings (cont).

(2) Lines and Fittings (cont).

STEP	LOCATION	ITEM	ACTION	REMARKS
INSTALLATION				
NOTE				
When connecting hoses, connect as tagged. When routing hoses, install clamps and new tie straps at locations noted during removal.				
10	Right hand hydraulic cylinder	a. Two elbows (48)	Install	In right hand hydraulic cylinder
		b. Tee (47)	Install	In elbow (48)
		c. Fitting (46)	Install	In tee (47)
		d. Velocity fuse (45)	Install	In fitting (46)
		e. Fitting (44)	Install	In velocity fuse (45)
		f. Hose assembly (43)	Connect and tighten fitting	To fitting (44)
		g. Bushing (42)	Install	In tee (47)
		h. Hose assembly (41)	Connect and tighten fitting	To bushing (42)
		i. Elbow (40)	Install	In right hand hydraulic cylinder
		j. Hose assembly (39)	Connect and tighten fitting	To elbow (40)
11	Left hand hydraulic cylinder	a. Elbow (38)	Install	In left hand hydraulic cylinder
		b. Hose assembly (37)	Connect and tighten fitting	To elbow (38)
		c. Two elbows (36)	Install	In left hand hydraulic cylinder
		d. Tee (35)	Install	In elbow (36)
		e. Fitting (34)	Install	In tee (35)
		f. Velocity fuse (33)	Install	In fitting (34)
		g. Fitting (32)	Install	In velocity fuse (33)
		h. Hose assembly (31)	Connect and tighten fitting	To fitting (32)

2-78. FIFTH WHEEL HYDRAULIC SYSTEM MAINTENANCE (CONT)

b. Hydraulic Filter and Lines and Fittings (cont).

(2) Lines and Fittings (cont).

STEP	LOCATION	ITEM	ACTION	REMARKS
INSTALLATION (cont)				
11 (cont)		i. Bushing (30)	Install	In tee (35)
		j. Bushing (29)	Install	In bushing (30)
		k. Hose assembly (28)	Connect and tighten fitting	
12	Fifth wheel boom cross- member, rear	a. Tee (27)	Position	At fifth wheel boom cross- member
		b. Hose assembly (28)	a. Route b. Connect c. Tighten fitting	To tee (27)
		c. Hose assembly (41)	a. Route b. Connect c. Tighten fitting	To tee (27)
		d. Tee (26)	a. Install	In fifth wheel boom cross- member projecting wall
		e. Tee (25)	b. Tighten nut a. Install	In fifth wheel boom cross- member projecting wall
		f. Plug (24)	b. Tighten nut Install	In tee (25)
		g. Hose assembly (37)	a. Route b. Connect c. Tighten fitting	To tee (26)
		h. Hose assembly (31)	a. Route b. Connect c. Tighten fitting	To tee (25)
		i. Hose assembly (39)	a. Route b. Connect c. Tighten fitting	To tee (26)
		j. Hose assembly (43)	a. Route b. Connect c. Tighten fitting	To tee (25)
		k. Hose assembly (23)	a. Connect b. Tighten fitting	To tee (27)

2-78. FIFTH WHEEL HYDRAULIC SYSTEM MAINTENANCE (CONT)

b. Hydraulic Filter and Lines and Fittings (cont).

(2) Lines and Fittings (cont).

STEP	LOCATION	ITEM	ACTION	REMARKS
INSTALLATION (cont)				
12 (cont)		l. Hose assembly (22)	a. Connect b. Tighten fitting	To tee (26)
		m. Hose assembly (21)	a. Connect b. Tighten fitting	To tee (25)
13	Hydraulic reservoir	a. Elbow (11)	Install	In hydraulic reservoir
		b. Elbow (10)	Install	In elbow (11)
		c. Nipple (9)	Install	In elbow (10)
		d. Return line filter head	Install	Para 2-78b(1)
		e. Hydraulic reservoir	Install	Para 2-78c
		f. Tee (20)	Install	In hydraulic reservoir
		g. Nipple (19)	Install	In tee (20)
		h. Two bushings (18 and 17)	Install	
		i. Elbow (16) and nipple (15)	Install	
		j. Bleed valve (14)	Install	On nipple (15)
		k. Handle and screw (13)	Install	On bleed valve (14)
		l. Adapter (12)	Install	In bleed valve (14)
		m. Hose assembly (23)	a. Route b. Connect c. Tighten fitting	To adapter (12)
n. Suction line filter head	Install	On nipple (19); para 2-78b(1)		
o. Two new filter elements	Install	Para 2-78b(1)		
14	Left hand frame rail	a. Hose assembly (8)	a. Connect b. Tighten fitting	To suction line filter head
		b. Hose assembly (7)	a. Connect b. Tighten fitting	To return line filter head

2-78. FIFTH WHEEL HYDRAULIC SYSTEM MAINTENANCE (CONT)

b. Hydraulic Filter and Lines and Fittings (cont).

(2) Lines and Fittings (cont).

STEP	LOCATION	ITEM	ACTION	REMARKS
INSTALLATION (cont)				
15	Hydraulic pump	a. Elbow (6)	Install	In hydraulic pump
		b. Hose assembly (8)	a. Route b. Connect	To elbow (6)
		c. Elbow (6)	Tighten nut	
		d. Elbow (5)	Install	In hydraulic pump
		e. Hose assembly (4)	a. Route b. Connect c. Tighten	To elbow (5)
16	Control valve	a. Three elbows (1 thru 3)	a. Install b. Tighten nuts	In hydraulic control valve Tighten O-ring locknuts
		b. Hose assembly (7)	a. Route b. Connect	To hydraulic control valve elbow
		c. Hydraulic control valve elbow	Tighten nut	
		d. Hose assembly (22)	a. Route b. Connect	To elbow (3)
		e. Elbow (3)	Tighten nut	
		f. Hose assembly (21)	a. Route b. Connect	
		g. Elbow (2)	Tighten nut	
		h. Hose assembly (4)	a. Route b. Connect	
		i. Elbow (1)	Tighten nut	
17	Left hand frame rail	Hydraulic reservoir	Fill	Para 2-78c

WARNING

Stand away from top of hydraulic reservoir when operating bleed valve. Hot oil may be expelled from filler cap. If you are burned by hot oil, obtain medical aid immediately.

2-78. FIFTH WHEEL HYDRAULIC SYSTEM MAINTENANCE (CONT)

b. Hydraulic Filter and Lines and Fittings (cont).

(2) Lines and Fittings (cont).

STEP	LOCATION	ITEM	ACTION	REMARKS
INSTALLATION (cont)				
18	Tractor	a. Bleed valve (14)	Open	Rotate handle 90 degrees
		b. Key switch	Turn on	
		c. Power take-off	Engage	
		d. Fifth wheel boom	Alternately raise and lower	Purges air from hydraulic system
		e. Bleed valve (14)	Close	
		f. Fifth wheel boom	Raise	
		g. All connections	Inspect	For hydraulic fluid leaks
		h. Fifth wheel boom	Lower	
		i. Key switch	Turn off	Press engine stop button to shut down engine
19	Tractor rear	Rear platform	Install	Para 2-65c

2-78. FIFTH WHEEL HYDRAULIC SYSTEM MAINTENANCE (CONT)

c. Hydraulic Reservoir.

- This task covers:
- a. Servicing
 - b. Removal
 - c. Cleaning
 - d. Inspection
 - e. Installation

INITIAL SETUP

Tools

No. 1 Common Organizational Maintenance

Tool Kit

- Socket wrench set
- Screwdriver
- Combination wrench set
- Scratch wire brush
- Safety glasses

Container, 16 gallons

Personnel Required

Two Wheel Vehicle Mechanics MOS 63B

References

TM 9-2320-285-10
(M878A1 Operator's Manual)

Equipment Condition

Paragraph Condition Description

Materials/Parts

- Cleaning solvent Item 1, Appendix C
- Clean cloths Item 2, Appendix C
- Hydraulic oil Item 22, Appendix C
- Detergent Item 27, Appendix C
- Thread sealant Item 29, Appendix C
- Gasket FSCM 55524 PN 8

Vehicle parked on level surface, engine off, and parking brake applied.

STEP	LOCATION	ITEM	ACTION	REMARKS
------	----------	------	--------	---------

SERVICING

WARNING

Do not remove filler cap (1) when hydraulic oil is hot. If you are injured by hot hydraulic oil, seek medical attention immediately.

1	Left hand frame rail	a. Filler cap (1)	Remove	Under magnetic drain plug (2)
		b. Container	Position	
		c. Magnetic drain plug (2)	Remove	
		d. Hydraulic oil	Drain	
		e. Magnetic drain plug (2)	a. Coat threads	
			b. Install	
		f. Hydraulic reservoir (9)	Fill	
		g. Filler cap (1)	Install	
	h. Bleed valve	Open		

2-78. FIFTH WHEEL HYDRAULIC SYSTEM MAINTENANCE (CONT)

c. Hydraulic Reservoir (cont).

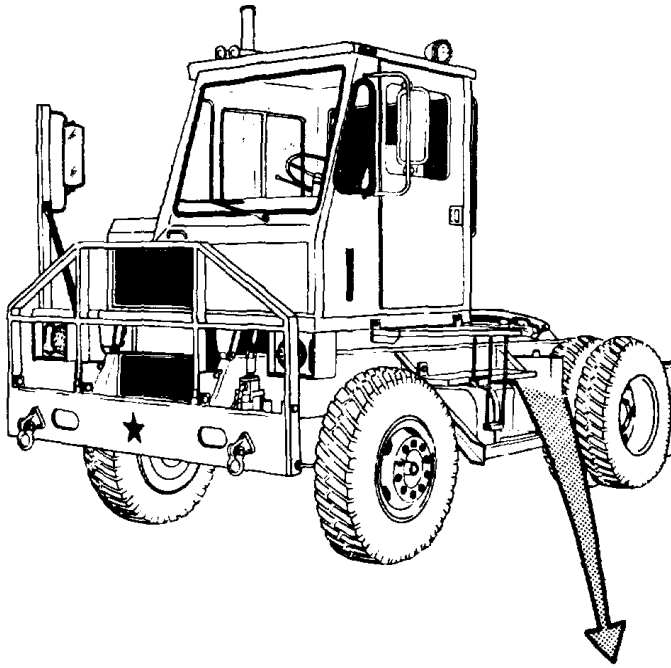

KEY

- 1. Filler cap
- 2. Magnetic drain plug
- 3. Screws (6)
- 4. Filler
- 5. Gasket
- 6. Lock nuts (4)
- 7. Washers (4)
- 8. Capscrews (4)
- 9. Hydraulic reservoir
- 10. Rubber pads (2)
- 11. Spacers (2)

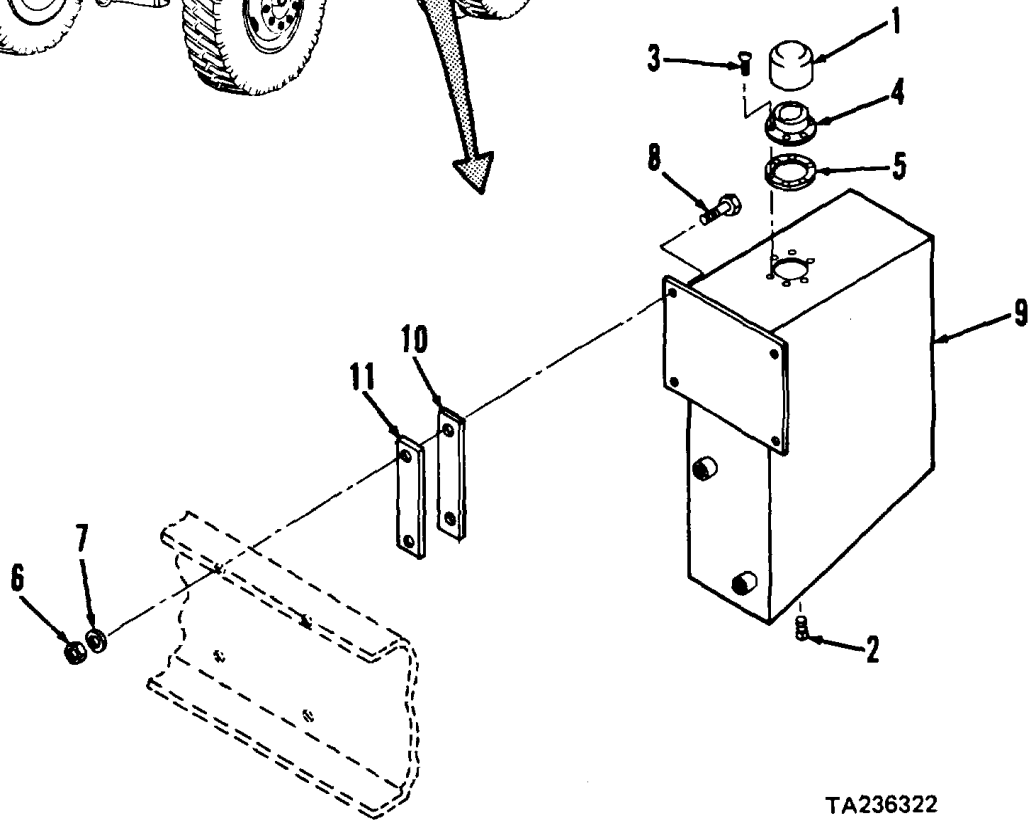

TA236322

2-78. FIFTH WHEEL HYDRAULIC SYSTEM MAINTENANCE (CONT)

c. Hydraulic Reservoir (cont).

STEP	LOCATION	ITEM	ACTION	REMARKS
SERVICING (cont)				
2	Cab interior	a. Key switch b. Power take-off c. Fifth wheel boom d. Power take-off e. Key switch	Turn on Engage Operate Disengage Turn off	Start engine Alternately raise and lower to purge air from hydraulic system; then lower fully Push engine stop button to shut down engine
3	Left hand frame rail	a. Bleed valve b. Filler cap (1) c. Hydraulic reservoir (9) d. Filler cap (1)	Close Remove Fill, if necessary Install	To level of screen using clean hydraulic oil
REMOVAL				
4	Left hand frame rail	a. Hydraulic oil b. Hydraulic hoses c. Hydraulic filter elements and suction line filter head d. Bleed valve, pipes, and fittings e. Six screws (3) f. Filler (4) and gasket (5) g. Four lock nuts (6), washers (7), and capscrews (8) h. Hydraulic reservoir (9), rubber pads (10), and spacers (11)	Drain Disconnect Remove Remove Remove Remove Remove	Steps 1a thru 1d above From hydraulic filters and bleed valve; para 2-78b(2) Para 2-78b(1) From hydraulic reservoir (9); para 2-78b(2) Discard gasket (5)

2-78. FIFTH WHEEL HYDRAULIC SYSTEM MAINTENANCE (CONT)

c. Hydraulic Reservoir (cont).

STEP	LOCATION	ITEM	ACTION	REMARKS
REMOVAL (cont)				
5	Hydraulic reservoir	Return line filter head and piping	Remove	Para 2-78b(2)

CLEANING

6		a. Rubber pads (10)	Clean using detergent solution; dry with clean cloths	
---	--	---------------------	---	--

WARNING

Dry cleaning solvent (P-D-680), used to clean parts is toxic and flammable. Wear protective goggles and gloves and use only in a well ventilated area. Avoid contact with skin, eyes, and clothes and don't breathe vapors. Do not use near open flame or excessive heat and don't smoke when using it. Failure to do so could cause serious injury. If you become dizzy while using cleaning solvent, get fresh air and medical attention immediately. If contact with skin or clothes is made, flush with large amounts of water. If contact with eyes is made, wash eyes with water and seek medical aid immediately.

Compressed air must not exceed 30 psi. Wear safety glasses when drying parts with compressed air. Failure to do so could cause serious injury to eyes and possible blindness. If you hurt your eyes or if a foreign object is blown into your eyes, seek medical attention immediately.

		b. Hydraulic reservoir (9)	Clean exterior with cleaning solvent P-D-680 and stiff bristled brush. Dry thoroughly with compressed air. Pour cleaning solvent P-D-680 into reservoir; agitate reservoir to thoroughly clean interior. Pour cleaning solvent out, and dispose of properly. Dry interior of reservoir with compressed air. When interior is thoroughly dry, flush reservoir interior with clean hydraulic oil. Then drain hydraulic oil and dispose of properly. Dry reservoir interior with compressed air	
		c. All other parts	Clean using cleaning solvent P-D-680; dry with compressed air	

2-78. FIFTH WHEEL HYDRAULIC SYSTEM MAINTENANCE (CONT)

c. Hydraulic Reservoir (cont).

STEP	LOCATION	ITEM	ACTION	REMARKS
INSPECTION				
7		a. Filler (4)	Inspect	Replace if cracked, deformed, or screen torn, clogged, or missing
		b. All other parts	Inspect	Replace if cracked, broken, distorted, or threads damaged
INSTALLATION				
8	Hydraulic reservoir	Return line filter head and piping	Install	Para 2-78b(2)
9	Left hand frame rail	a. Hydraulic reservoir (9), spacers (11), and rubber pads (10)	Position	
		b. Four capscrews (8), washers (7), and lock nuts (6)	Install and tighten	
		c. Filler (4) with new gasket (5)	Position	On hydraulic reservoir (9)
		d. Six screws (3)	Install and tighten	
		e. Magnetic drain plug (2)	a. Coat threads	Use pipe thread sealant
		f. Fittings, pipes and bleed valve	b. Install	Tighten securely
		g. Suction line filter head and new elements	Install	On hydraulic reservoir (9); para 2-78b(2)
		h. Hydraulic hoses	Install	Para 2-78b(1)
		i. Hydraulic reservoir (9)	Connect	To hydraulic filters and bleed valve; para 2-78b(2)
		j. All connections	Fill	Steps 1 thru 3 above
			Check	For leaks

2-79. CAB TILT HYDRAULIC SYSTEM MAINTENANCE

a. Cab Tilt Hydraulic Pump.

This task covers: a. Removal c. Inspection
 b. Cleaning d. Installation
 e. Servicing

INITIAL SETUP

Tools

No. 1 Common Organizational Maintenance

Tool Kit

- Safety glasses
- Socket wrench set

Materials/Parts

- Cleaning solvent Item 1, Appendix C
- Clean cloths Item 2, Appendix C
- Transmission fluid Item 8, Appendix C

Personnel Required

Wheel Vehicle Mechanic MOS 63B

References

TM 9-2320-285-10
 (M878A1 Operator's Manual)

Equipment Condition

Paragraph	Condition Description
2-79b	Vehicle parked on level surface, engine off, and parking brake applied. Hydraulic pressure relieved; lines and fittings removed from hydraulic pump.

KEY

- 1. Pump handle
- 2. Capscrews (2)
- 3. Lock washers (2)
- 4. Filler plug
- 5. Flow control valve

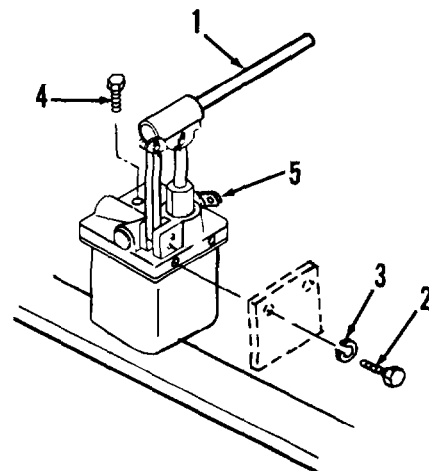
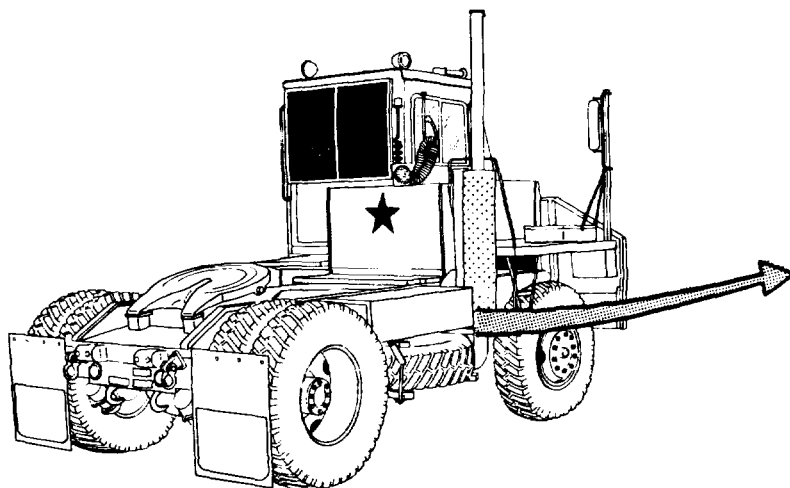

TA236385

2-79. CAB TILT HYDRAULIC SYSTEM MAINTENANCE (CONT)

a. Cab Tilt Hydraulic Pump (cont).

STEP	LOCATION	ITEM	ACTION	REMARKS
REMOVAL				
1	Frame rail, right hand side	a. Pump handle (1)	Remove	If installed
		b. Two capscrews (2) and lock washers (3)	Remove	Support hydraulic pump
		c. Hydraulic pump	Remove	From tractor
CLEANING				
<u>WARNING</u>				
Dry cleaning solvent (P-D-680), used to clean parts is toxic and flammable. Wear protective goggles and gloves and use only in a well ventilated area. Avoid contact with skin, eyes, and clothes and don't breathe vapors. Do not use near open flame or excessive heat and don't smoke when using it. Failure to do so could cause serious injury. If you become dizzy while using cleaning solvent, get fresh air and medical attention immediately. If contact with skin or clothes is made, flush with large amounts of water. If contact with eyes is made, wash eyes with water and seek medical aid immediately.				
2		All parts	Clean	Use cleaning solvent P-D-680; dry thoroughly with compressed air or clean cloths
INSPECTION				
3		a. Pump handle (1)	Inspect	Replace if cracked or broken
		b. Capscrews (2), lock washers (3), and fil- ler plug (4)	Inspect	Replace if cracked, broken, distorted, or threads damaged
INSTALLATION				
4	Frame rail, right hand side	a. Hydraulic pump	Position	Against mounting bracket
		b. Two lock wash- ers (3) and capscrews (2)	Install and tighten	
		c. Pump handle (1)	Install	

2-79. CAB TILT HYDRAULIC SYSTEM MAINTENANCE (CONT)

a. Cab Tilt Hydraulic Pump (cont).

STEP	LOCATION	ITEM	ACTION	REMARKS
INSTALLATION (cont)				
5	Hydraulic hose assemblies	Lines and fittings	Install and connect	Para 2-79b
SERVICING				
6	Hydraulic pump	a. Filler plug (4) b. Hydraulic pump c. Filler plug (4)	Remove Fill Install and tighten	With transmission fluid
7	Hydraulic pump	a. Pump handle	Position	In hydraulic pump

WARNING

Stay out from under raised cab unless safety bar is supporting full weight of cab. Failure to follow this procedure could result in severe injury from falling cab.

NOTE

Do not allow cab to fall quickly; velocity fuse will set and cab will not lower.

b. Hydraulic pump	Operate	Alternately raise and lower cab to make certain that system is operating properly
c. Cab	Lower, if necessary	To normal operating position
d. Fluid level	Check	Add transmission fluid if necessary (step 6 above)
e. Pump handle (1)	a. Remove b. Store	In holder in cab

2-79. CAB TILT HYDRAULIC SYSTEM MAINTENANCE (CONT)

b. Lines and Fittings.

This task covers: a. Removal c. Inspection
 b. Cleaning d. Installation

INITIAL SETUP

Tools

No. 1 Common Organizational Maintenance Tool Kit
 Adjustable open end wrench
 Combination wrench set
 Safety glasses

Materials/Parts

Cleaning solvent Item 1, Appendix C
 Clean cloths Item 2, Appendix C
 Transmission fluid Item 8, Appendix C
 Tags Item 14, Appendix C

Personnel Required

Wheel Vehicle Mechanic MOS 63B

Equipment Condition

Paragraph Condition Description

Vehicle parked on level surface, engine off, and parking brake applied.
 Cab tilted 45 degrees; safety bar engaged.

KEY

- | | | |
|------------------|------------------|-------------------|
| 1. Fitting | 7. Tee | 13. Fitting |
| 2. Hose assembly | 8. Adapter | 14. Fitting |
| 3. Fitting | 9. Union adapter | 15. Hose assembly |
| 4. Elbow | 10. Locknuts (2) | 16. Tee |
| 5. Fitting | 11. Washers (2) | 17. Adapter |
| 6. Hose assembly | 12. Clamps (2) | 18. Fitting |

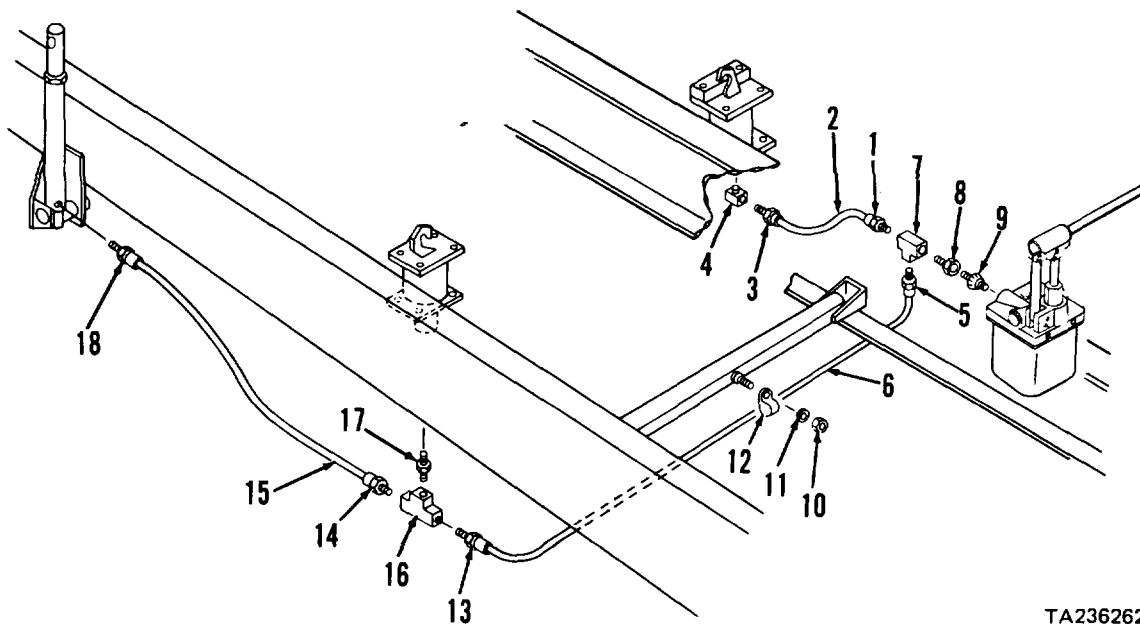

TA236262

2-79. CAB TILT HYDRAULIC SYSTEM MAINTENANCE (CONT)

b. Lines and Fittings (cont).

STEP	LOCATION	ITEM	ACTION	REMARKS
REMOVAL				
1	Cab tilt pump	Flow control valve	Open	Rotate to left to relieve all hydraulic pressure
NOTE				
Tag all hose assemblies before removal.				
2	Right hand frame rail	a. Fitting (1) b. Hose assembly (2) c. Fitting (3) d. Hose assembly (2) e. Elbow (4) f. Fitting (5) g. Hose assembly (6) h. Tee (7), adapter (8), and union adapter (9)	Loosen Disconnect Loosen a. Disconnect b. Remove Remove Loosen Disconnect Remove	 From tractor From cab tilt pump
3	Frame crossmember	Two locknuts (10), washers (11), and clamps (12)	Remove	
4	Left hand frame rail	a. Fitting (13) b. Hose assembly (6) c. Fitting (14) d. Hose assembly (15) e. Tee (16) and adapter (17) f. Fitting (18) g. Hose assembly (15)	Loosen a. Disconnect b. Remove Loosen Disconnect Remove Loosen a. Disconnect b. Remove	 From tractor From hydraulic latch From hydraulic cylinder From tractor

2-79. CAB TILT HYDRAULIC SYSTEM MAINTENANCE (CONT)

b. Lines and Fittings (cont).

STEP	LOCATION	ITEM	ACTION	REMARKS
CLEANING				
5		a. Three hose assemblies (2, 6, and 15)	Clean	Use clean cloth moistened with clean transmission fluid
<u>WARNING</u>				
<p>Dry cleaning solvent (P-D-680), used to clean parts is toxic and flammable. Wear protective goggles and gloves and use only in a well ventilated area. Avoid contact with skin, eyes, and clothes and don't breathe vapors. Do not use near open flame or excessive heat and don't smoke when using it. Failure to do so could cause serious injury. If you become dizzy while using cleaning solvent, get fresh air and medical attention immediately. If contact with skin or clothes is made, flush with large amounts of water. If contact with eyes is made, wash eyes with water and seek medical aid immediately.</p> <p>Compressed air must not exceed 30 psi. Wear safety glasses when drying parts with compressed air. Failure to do so could cause serious injury to eyes and possible blindness. If you hurt your eyes or if a foreign object is blown into your eyes, seek medical attention immediately.</p>				
		b. All other parts	Clean	Use cleaning solvent P-D-680; dry with compressed air
INSPECTION				
6		a. Rose assemblies and fittings	Inspect	Replace if cracked, worn, chafed, broken, or threads damaged
		b. All other parts	Inspect	Replace if cracked, split, or threads damaged
INSTALLATION				
7	Left hand frame rail	a. Hose assembly (15)	Connect	
		b. Fitting (18)	Tighten	
		c. Tee (16) and adapter (17)	Install	

2-79. CAB TILT HYDRAULIC SYSTEM MAINTENANCE (CONT)

b. Lines and Fittings (cont).

STEP	LOCATION	ITEM	ACTION	REMARKS
INSTALLATION (cont)				
7 (cont)		d. Hose assembly (15)	Connect	
		e. Fitting (14)	Tighten	
		f. Hose assembly (6)	Connect	
		g. Fitting (13)	Tighten	
8	Frame crossmember	Two clamps (12), washers (11), and locknuts (10)	Install and tighten	Around hose assembly (6)
9	Right hand frame rail	a. Union adapter (9), adapter (8), and tee (7)	Install and tighten	On cab tilt pump
		b. Hose assembly (6)	Connect	
		c. Fitting (5)	Tighten	
		d. Elbow (4)	Install	
		e. Hose assembly (2)	Connect	To cab tilt pump
		f. Fitting (3)	Tighten	
		g. Hose assembly	Connect	To hydraulic latch
		h. Fitting (1)	Tighten	
		i. Cab tilt pump	Service	Para 2-79a

Section XII. GAGES MAINTENANCE

This section contains the information you need to maintain the:

- Speedometer
- Tachometer
- Pressure Gages
- Hourmeter

It gives you instructions on how to troubleshoot problems and repair or replace the components that are within the scope of organizational maintenance.

	Para		Para
Troubleshooting Symptom Index.....	2-80	Tachometer Maintenance	2-86
Speedometer Troubleshooting	2-81	Pressure Gages Maintenance	2-87
Tachometer Troubleshooting	2-82	OIL PRESS Gage	2-87a
Pressure Gages Troubleshooting.....	2-83	AIR PRESS Gage	2-87b
Hourmeter Troubleshooting.....	2-84	FUEL Gage	2-87c
Speedometer Maintenance	2-85	WATER TEMP Gage	2-87d
		Hourmeter Maintenance	

2-80. TROUBLESHOOTING SYMPTOM INDEX

	Para/Malfunction	Page
SPEEDOMETER		
Pointer moves erratically or scraping noise is heard	2-81/1	2-907
TACHOMETER		
Tachometer inoperative or does not indicate correct engine speed	2-82/1	2-908
PRESSURE GAGES		
WATER TEMP, OIL PRESS, or FUEL gage inoperative.....	2-83/1	2-908
AIR PRESS gage doesn't indicate correct air pressure.....	2-83/2	2-909
HOURMETER		
Hourmeter inoperative	2-84/1	2-910

2-81. SPEEDOMETER TROUBLESHOOTING**MALFUNCTION****TEST OR INSPECTION****CORRECTIVE ACTION****1. POINTER MOVES ERRATICALLY OR SCRAPING NOISE IS HEARD**

Step 1. Remove speedometer cable and check if speedometer cable is kinked (para 2-85).

- a. If speedometer cable is kinked, replace (para 2-85).
- b. If speedometer cable is not kinked, go to step 2 below.

Step 2. Check speedometer cable for inadequate lubrication.

- a. If speedometer cable is inadequately lubricated, lubricate (para 2-85).
- b. If speedometer cable is adequately lubricated, go to step 3 below.

Step 3. Inspect speedometer cable housing for dents, sharp bends, or other damage.

- a. If speedometer cable housing is damaged, replace speedometer cable and housing (para 2-85).
- b. If speedometer cable housing is not damaged, go to step 4 below.

Step 4. Replace speedometer head (para 2-85).

- a. If malfunction is corrected, speedometer head was defective; no further action is required.
- b. If malfunction is not corrected, go to step 5 below.

Step 5. Replace speedometer adapter and gear assembly (para 2-85).

- a. If malfunction is corrected, speedometer adapter or gear assembly was defective; no further action is required.
- b. If malfunction is not corrected, transmission requires repair; notify direct support maintenance.

2-82. TACHOMETER TROUBLESHOOTING

MALFUNCTION**TEST OR INSPECTION****CORRECTIVE ACTION****1. TACHOMETER INOPERATIVE OR DOES NOT INDICATE CORRECT ENGINE SPEED**

- Step 1. Raise instrument panel (para 2-26g(1)).
Check tachometer head and sender unit for loose or incorrect connections or broken conductor.
- a. If connections are loose or incorrect, tighten or correct (para 2-86).
 - b. If conductor is broken, replace (para 2-86).
 - c. If connections and conductor are okay, go to step 2 below.
- Step 2. Check if tachometer head adjustment screw is at position #3.
- a. If adjustment screw is not at position #3, turn to position #3 (para 2-86).
 - b. If adjustment screw is at position #3, go to step 3 below.
- Step 3. Replace tachometer head (para 2-86).
- a. If malfunction is corrected, no further action is required.
 - b. If malfunction is not corrected, replace sender unit (para 2-86).

2-83. PRESSURE GAGES TROUBLESHOOTING

MALFUNCTION**TEST OR INSPECTION****CORRECTIVE ACTION****1. WATER TEMP, OIL PRESS, OR FUEL GAGE INOPERATIVE**

- Step 1. Turn key switch to off position.
Raise instrument panel (para 2-26g(1)).
Connect two flashlight batteries in series and connect (+) and (-) terminals across gage terminals using jumper wires (if gage pointer deflects downscale, reverse jumper wires).
Watch gage pointer.
- a. If gage pointer does not deflect to approximately full scale, gage is defective; replace (para 2-87a, 2-87c, or 2-87d).
 - b. If gage pointer deflects approximately full scale, go to step 2.

2-83. PRESSURE GAGES TROUBLESHOOTING (CONT)
--

MALFUNCTION**TEST OR INSPECTION****CORRECTIVE ACTION****1. WATER TEMP, OIL PRESS, OR FUEL GAGE INOPERATIVE (Cont)**

Step 2. Remove gage electrical lead at sending unit; have assistant momentarily ground electrical lead to engine block or frame of tractor. Start engine; watch gage pointer.

- a. If gage pointer deflects to approximately full scale, sending unit is defective; replace (para 2-32a, 2-32c, or 2-32d).
- b. If gage pointer does not deflect, go to step 3 below.

Step 3. Check gage for loose or incorrect connections and broken conductor.

- a. If connections are loose or incorrect, tighten or correct (para 2-87a, 2-87c, or 2-87d).
- b. If conductor is broken, replace (para 2-87a, 2-87c, or 2-87d).

2. AIR PRESS GAGE DOESN'T INDICATE CORRECT AIR PRESSURE

Step 1. Raise instrument panel (para 2-26g(1)).
Check AIR PRESS gage hose for restrictions (sharp bends, blockage).

WARNING

Compressed air must not exceed 30 psi. Wear safety glasses when using compressed air. Failure to do so could cause serious injury to eyes and possible blindness. If you hurt your eyes or if a foreign object is blown into your eyes, seek medical aid immediately.

- a. If hose is blocked, use compressed air (30 psi maximum) to remove blockage; if hose remains blocked, replace (para 2-87b).
- b. If hose is not blocked, go to step 2 below.

Step 2. Open drain cock on service air tank to relieve air system pressure. Disconnect electrical leads from terminals of low air pressure switch, and remove switch (para 2-51c). Install a calibrated air pressure gage in tee from which low air pressure switch was removed. Close drain cock on service air tank. Start engine and allow air system to charge to 50-100 psi. Compare indication on AIR PRESS gage with indication on test gage.

If AIR PRESS gage indication differs from test gage indication by more than 10 psi, replace AIR PRESS gage (para 2-87b).

2-84. HOURMETER TROUBLESHOOTING

MALFUNCTION

TEST OR INSPECTION

CORRECTIVE ACTION

1. HOURMETER INOPERATIVE

- Step 1. Raise instrument panel (para 2-26g(1)).
Unplug electrical leads from hourmeter terminals (para 2-88).
Using 12 volt battery and jumper cables, apply 12Vdc across hourmeter terminals (be sure to use correct polarity).
Record hourmeter display time to nearest 1/10 hour; watch hourmeter for six minutes.
- a. If hourmeter display does not advance approximately 1/10 hour, hourmeter is defective; replace (para 2-88).
 - b. If hourmeter display advances approximately 1/10 hour, go to step 2 below.
- Step 2. Raise instrument panel (para 2-26g(1)).
Check hourmeter for loose or incorrect connections and broken conductor.
- a. If connections are loose or incorrect, tighten or correct (para 2-88).
 - b. If conductor is broken, replace (para 2-88).

2-85. SPEEDOMETER MAINTENANCE

- This task covers
- a. Removal
 - b. Cleaning
 - c. Inspection
 - d. Installation

INITIAL SETUP

Tools
 No. 1 Common Organizational Maintenance
Tool Kit
 Socket wrench set
 Combination wrench set
 Safety glasses

Personnel Required
 Wheel Vehicle Mechanic MOS 63B

Equipment Condition

Paragraph	Condition	Description
		Parked on level surface engine off, and parking brake applied.
2-34a		Battery ground cable disconnected.
2-65c		Rear platform removed.

Materials/Parts

Cleaning
 solvent Item 1, Appendix C
 Clean cloths Item 2, Appendix C
 Grease Item 26, Appendix C
 7 tie straps FSCM 96906 PN MS3667-1-9

STEP	LOCATION	ITEM	ACTION	REMARKS
------	----------	------	--------	---------

REMOVAL

1	Instrument panel	a. Cable nut (1)	Loosen	
		b. Cable housing (2)	Disconnect	Pull from speedometer head (6)
		c. Instrument	Raise	Para 2-26g(1)
		d. Speedometer light socket with bulb	Unplug	From speedometer head; para 2-26d(1)
		e. Two nuts (3), lock washers (4), and	Remove	
		f. Speedometer head (6)	Remove	Lift from instrument panel
2	Cab tilt pump	Cab	degrees	Tilt 45
3	Transmission rear, left side(2)	a. Cable nut (7)	Loosen	
		b. Cable housing	Disconnect	Pull from adapter (8)
		c. Adapter (8)	Remove	
		d. Gear assembly (9)	Remove	

2-85. SPEEDOMETER MAINTENANCE (CONT)

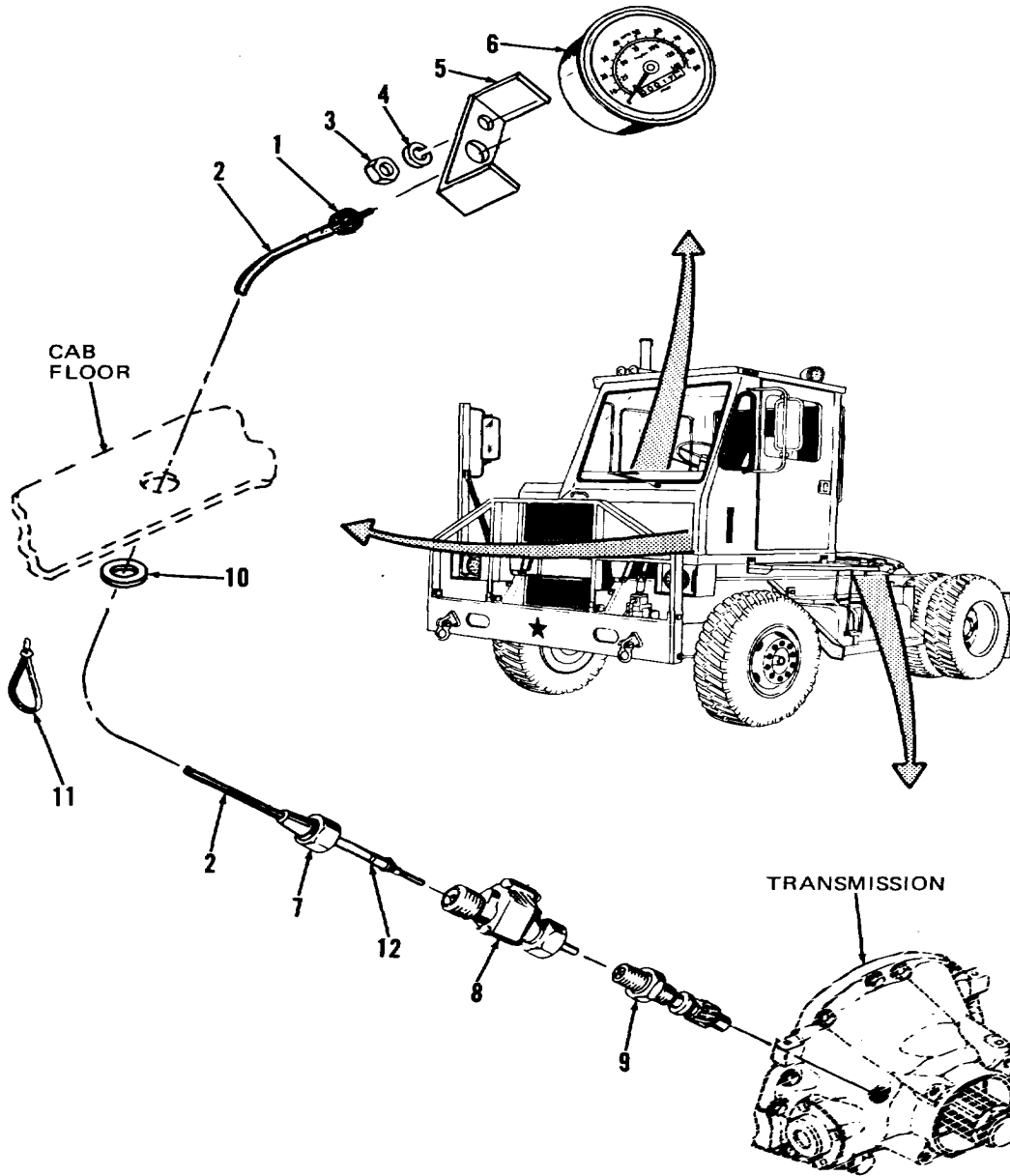

TA236294

KEY

1. Cable nut
2. Cable housing
3. Nuts (2)
4. Lock washers (2)
5. Bracket
6. Speedometer head
7. Cable nut
8. Adapter
9. Gear assembly
10. Grommet
11. Tie straps (7)
12. Speedometer cable

2-85. SPEEDOMETER MAINTENANCE (CONT)

STEP	LOCATION	ITEM	ACTION	REMARKS
REMOVAL (cont)				
4	Cab floor	Cable housing (2) and grommet (10)	Pull out	From underside of cab floor
5	Left hand frame rail	a. Seven tie straps (11) b. Cable housing (2)	Cut, remove, and discard Remove	Note locations to aid instal- lation From vehicle
6	Cable housing (2)	Speedometer cable (12)	Remove	Pull from cable housing (2)

CLEANING

7		a. Cable housing (2), cable nuts (1 and 7), and speedometer head (6)	Clean	Wipe with clean, dry cloth
---	--	---	-------	----------------------------

WARNING

Dry cleaning solvent (P-D-680), used to clean parts is toxic and flammable. Wear protective goggles and gloves and use only in a well ventilated area. Avoid contact with skin, eyes, and clothes and don't breathe vapors. Do not use near open flame or excessive heat and don't smoke when using it. Failure to do so could cause serious injury. If you become dizzy while using cleaning solvent, get fresh air and medical attention immediately. If contact with skin or clothes is made, flush with large amounts of water. If contact with eyes is made, wash eyes with water and seek medical aid immediately.

Compressed air must not exceed 30 psi. Wear safety glasses when drying parts with compressed air. Failure to do so could cause serious injury to eyes and possible blindness. If you hurt your eyes or if a foreign object is blown into your eyes, seek medical attention immediately.

b. All other parts	Clean	Use cleaning solvent P-D-680; dry with compressed air or clean cloths
--------------------	-------	---

2-85. SPEEDOMETER MAINTENANCE (CONT)

STEP	LOCATION	ITEM	ACTION	REMARKS
INSPECTION				
8	a.	Cable housing (2) with nuts (1 and 7)	Inspect	Replace if nuts cracked, broken, or threads or if cable housing broken, cracked, or deteriorated
		b. Speedometer	Inspect head (6)	Replace if cracked, broken, pointer broken or bent, mechanism binding or frozen
		c. Speedometer cable (12)	Inspect	Place cable on flat surface, then twist one end with fingers. A good cable will turn over smoothly over entire length. Kinked cable will flop over after initial twisting motion. Replace if kinked or other- wise damaged
		d. Adapter (8) and gear assembly (9)	Inspect	Turn shaft to check for free- dom of movement. Replace cracked, broken, threads damaged, binding or frozen, or teeth broken or missing
		e. All other parts	Inspect	Replace if cracked, broken, distorted, or threads damaged
INSTALLATION				
9	Left hand	a. Cable housing	Route	
		b. Seven new tie straps (11)	Install	At locations noted during removal
10	Cab floor	Cable housing (2) and grommet (10)	Install	Through cab floor into cab
11	Transmis- sion rear,(9) left side	a. Gear assembly	Install	Make certain that gear teeth mesh properly with speedometer gear on transmission
		b. Adapter (8)	Install	
		c. Cable housing (2)	Connect	To adapter (8)
		d. Cable nut (7)	Tighten	
12	Cab tilt pump	Cab		Lower To normal operating position

2-85. SPEEDOMETER MAINTENANCE (CONT)

STEP	LOCATION	ITEM	ACTION	REMARKS
INSTALLATION (cont)				
13	Cable housing (2)	Speedometer cable (12)	a. Lubricate b. Install	With Lubriplate mag 1 In cable housing, from instrument panel end
14	Instrument panel	a. Speedometer head (6) b. Bracket (5) c. Two lock washers (4) and nuts (3) d. Speedometer light socket with bulb e. Instrument panel f. Cable housing (2) g. Cable nut (1)	Install Position Install and tighten Install Lower and secure Connect Tighten	In instrument panel Para 2-26d(1) Para 2-26g(1) To speedometer head (6)
15	Battery box	Battery ground cable	Connect	Para 2-34a
16	Tractor frame	Rear platform	Install	Para 2-65c

2-86. TACHOMETER MAINTENANCE

- This task covers:
- a. Removal
 - b. Cleaning
 - c. Inspection
 - d. Installation
 - e. Test

INITIAL SETUP

Tools

No. 1 Common Organizational Maintenance
 Socket wrench set
 Combination wrench set
 Safety glasses

Personnel Required

Wheel Vehicle Mechanic HOS 63B

Equipment Condition

Paragraph Condition Description

Materials/Parts

Cleaning solvent Item 1, Appendix C
 Clean cloths Item 2, Appendix C
 Fine sandpaper Item 4, Appendix C
 Tags Item 14, Appendix C
 Gasket FSCM 72582 PN 5136678
 Gasket FSCM 72582 PN 5135978

Parked on level surface; parking brake applied; engine off.
 2-34a Battery ground cable disconnected.
 2-26g(1) Instrument panel raised.
 3-17f Transmission mount removed (for tachometer drive removal)

STEP	LOCATION	ITEM	ACTION	REMARKS
------	----------	------	--------	---------

REMOVAL

NOTE

Tag and identify all electrical leads before disconnecting and removing.

1	Instrument panel	a. Tachometer light socket with bulb	Unplug	From tachometer head; para 2-26d(1)
		b. Three electrical leads (3 thru 5)	Tag	
		c. Two nuts (1) and lock washers (2)	Remove	
		d. Three electrical leads (3 thru 5)	Disconnect	From tachometer head (9)
		e. Two nuts (6), lock washers (7), and bracket (8)	Remove	
		f. Tachometer head (9)	Remove	Lift from instrument panel

2-86. TACHOMETER MAINTENANCE (CONT)

Key

- 1. Nut (2)
- 2. Lock washers (2)
- 3. Electrical lead (GRA)
- 4. Electrical lead (GRA/BLK)
- 5. Electrical lead (BRN/WHT)
- 6. Nuts (2)
- 7. Lock washers (2)
- 8. Bracket
- 9. Tachometer head
- 10. Electrical lead (WHT)
- 11. Nuts (3)

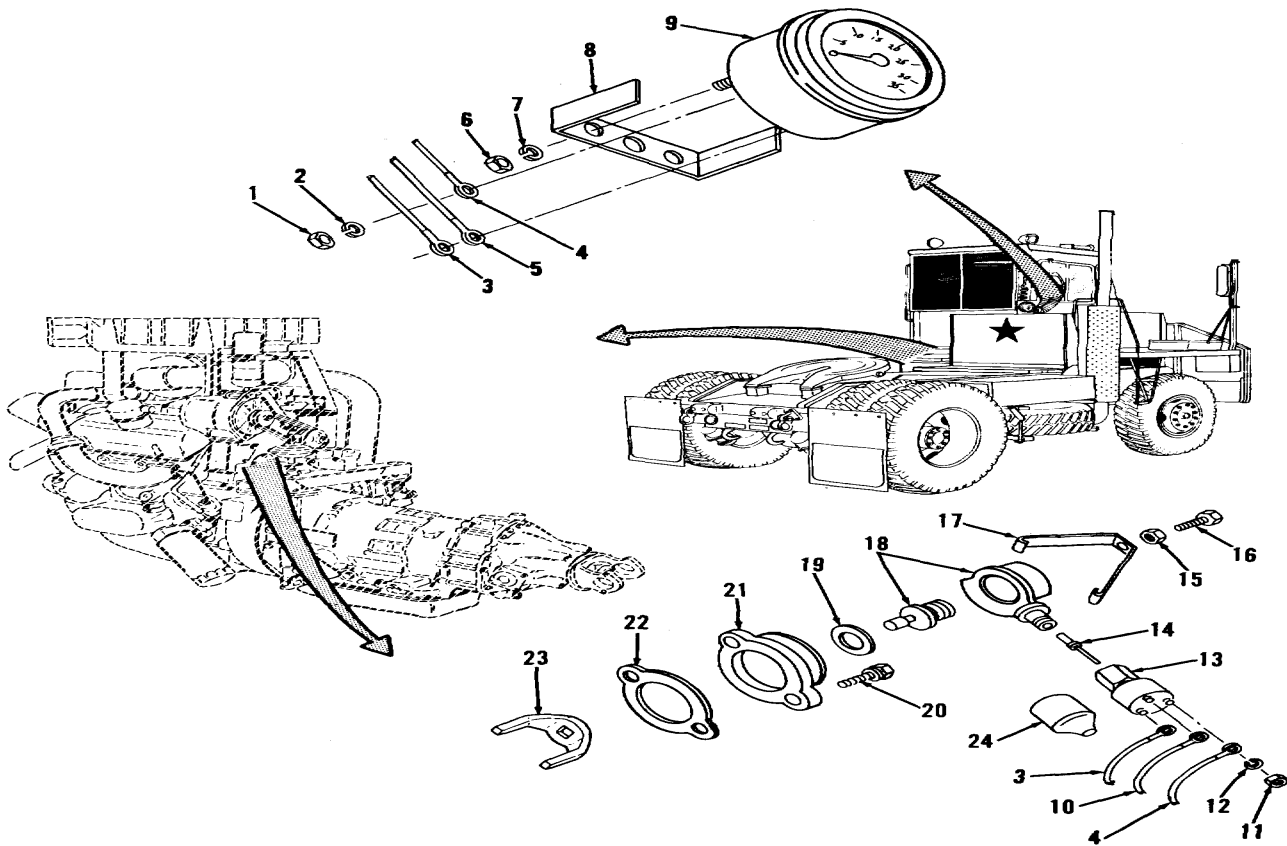

- 12. Lock washers (3)
- 13. Sender unit
- 14. Drive tip
- 15. Nut
- 16. Capscrew
- 17. Clamp
- 18. Drive assembly
- 19. Gasket
- 20. Capscrews (2)
- 21. Flange
- 22. Gasket
- 23. Fork
- 24. Rubber boot

TA236296

2-86. TACHOMETER MAINTENANCE (CONT)
--

STEP	LOCATION	ITEM	ACTION	REMARKS
REMOVAL (cont)				
2	Cab tilt pump	Cab	Tilt 45 degrees	
3	Engine, rear(24)	a. Rubber boot	Move	Pull from sender unit (13) and slide over leads
		b. Three electrical leads (3, 4, and 10)	Tag	
		c. Three nuts (11) and lock washers (12)	Remove	
		d. Three electrical leads (3, 4, and 10)	Disconnect	
		e. Rubber boot	Remove	From leads (3, 4, and 10)
		f. Sender unit (13)	Remove	Unscrew from drive assembly (18)
		g. Drive tip (14)	Remove	From sender unit (13) or drive assembly (18)
		h. Nut (15) and capscrew (16)	Loosen	
		i. Clamp (17) with nut (15) and capscrew (16)	Remove	
		j. Drive assembly (18)	Remove	
		k. Gasket (19)	Remove and discard	

CAUTION

Be sure you do not drop any parts into engine in following steps. Removal of dropped parts may require partial engine disassembly (notify direct support maintenance). Do not start engine unless dropped part is removed to prevent foreign object damage to engine.

l. Two capscrews (20), flange (21), and gasket (22)	Remove	Discard gasket (22)
m. Fork (23)	Remove	

2-86. TACHOMETER MAINTENANCE (CONT)
--

STEP	LOCATION	ITEM	ACTION	REMARKS
------	----------	------	--------	---------

REMOVAL (cont)

NOTE

Notify direct support maintenance if tachometer drive gear or adapter replacement is required (refer to TM 9-2815-205-34).

CLEANING

4		a. Tachometer head (9), sender unit (13), rubber boot (24) and electrical leads (3, 4, 5, and 10)	Clean	Wipe with clean, dry cloth
---	--	---	-------	----------------------------

WARNING

Dry cleaning solvent (P-D-680), used to clean parts is toxic and flammable. Wear protective goggles and gloves and use only in a well ventilated area. Avoid contact with skin, eyes, and clothes and don't breathe vapors. Do not use near open flame or excessive heat and don't smoke when using it. Failure to do so could cause serious injury. If you become dizzy while using cleaning solvent, get fresh air and medical attention immediately. If contact with skin or clothes is made, flush with large amounts of water. If contact with eyes is made, wash eyes with water and seek medical aid immediately.

Compressed air must not exceed 30 psi. Wear safety glasses when drying parts with compressed air. Failure to do so could cause serious injury to eyes and possible blindness. If you hurt your eyes or if a foreign object is blown into your eyes, seek medical attention immediately.

		b. All other parts	Clean	Use cleaning solvent P-D-680; dry with compressed air
--	--	--------------------	-------	---

2-86. TACHOMETER MAINTENANCE (CONT)

STEP	LOCATION	ITEM	ACTION	REMARKS
INSPECTION				
5		a. Tachometer head (9) and sender unit (13)	Inspect	Replace if cracked, broken, or inoperative. If electrical contacts dirty or discolored, polish to brightness with fine sandpaper.
		b. Electrical leads (3, 4, 5, and 10)	Inspect	Replace if insulation frayed, cut, or cracked or if conductor corroded or broken.
		c. Drive assembly (18)	Inspect	Check for freedom of rotation. Replace if bound or frozen.
		d. All other parts	Inspect	Replace if cracked, broken, distorted, or threads damaged.

INSTALLATION

CAUTION

Be sure you do not drop any parts into engine in following steps. Removal of dropped parts may require partial engine disassembly (notify direct support maintenance). Do not start engine unless dropped part is removed to prevent foreign object damage to engine.

6	Engine, rear	a. Fork (23)	Install	
		b. New gasket (22)	Position	
		c. Flange (21) and two capscrews (20)	Install	Tighten capscrews (20)
		d. New gasket (19)	Install	On drive assembly (18)
		e. Drive assembly (18) and clamp (17)	Install	
		f. Capscrew (16)	Tighten	
		g. Nut (15)	Tighten	Hold capscrew (16) stationary while tightening nut
		h. Drive tip (14) and sender	Install	
		i. Rubber boot (24)	Position	Slide onto electrical leads (3, 4, and 10)
		j. Three electrical leads (3, 4, and 10)	Connect as tagged	Lead (3) to "+" terminal; lead (4) to "S" terminal; lead (10) to "-" terminal
		k. Three nuts (11) and lock washers (12)	Install and tighten	

2-86. TACHOMETER MAINTENANCE (CONT)

STEP	LOCATION	ITEM	ACTION	REMARKS
INSTALLATION (cont)				
6 (cont)		l. Rubber boot (24)	Install	On sender unit (13)
		m. Transmission mount	Install	Para 3-17f
7 position	Cab tilt pump	Cab		Lower To normal operating
8	Instrument panel	a. Tachometer head (9)	a. Adjust	Turn adjustment screw on tachometer head to position number 3 In instrument panel
		b. Bracket (8)	b. Install Position	
		c. Two lock washers (7) and	Install and tighten	
		d. Three electrical leads (3 thru 5)	Connect as tagged	Leads (3 and 5) to "BAT" terminal; lead (4) to "IGN" terminal
		e. Two lock washers (2) and nuts (1)	Install and tighten	
		f. Tachometer light socket with bulb	Install	Para 2-26d(1)
		g. Instrument panel	Lower and secure	Para 2-26g(1)
9	Battery box	Battery ground cable	Connect	Para 2-34a
TEST				
10	Tractor	a. Test tachometer	Connect Start Watch	Check accuracy of tractor tachometer; error must be less than five percent (100 rpm error at 2000 rpm). Replace tachometer head (9) or sender unit (13) if tachometer error is more than five percent
		b. Engine		
		c. Test tachometer		
		d. Engine	Stop	
		e. Test tachometer	Disconnect	

2-87. PRESSURE GAGES MAINTENANCE

a. OIL PRESSURE Gage.

This task covers:

- a. Removal
- b. Cleaning
- c. Inspection
- d. Installation

INITIAL SETUP

Tools

No. 1 Common Organizational Maintenance Tool Kit

- Socket wrench set
- Safety glasses

Materials/Parts

- Cleaning solvent Item 1, Appendix C
- Clean cloths Item 2, Appendix C
- Fine sandpaper Item 4, Appendix C
- Tags Item 14, Appendix C

Equipment Condition

Paragraph Condition Description

- 2-34a Vehicle parked on level surface, engine off, and parking brake applied. Battery ground cable disconnected.
- 2-26g(1) Instrument panel raised.
- 2-26d(l) Gage light socket with bulb removed.

Personnel Required

Wheel Vehicle Mechanic MOS 63B

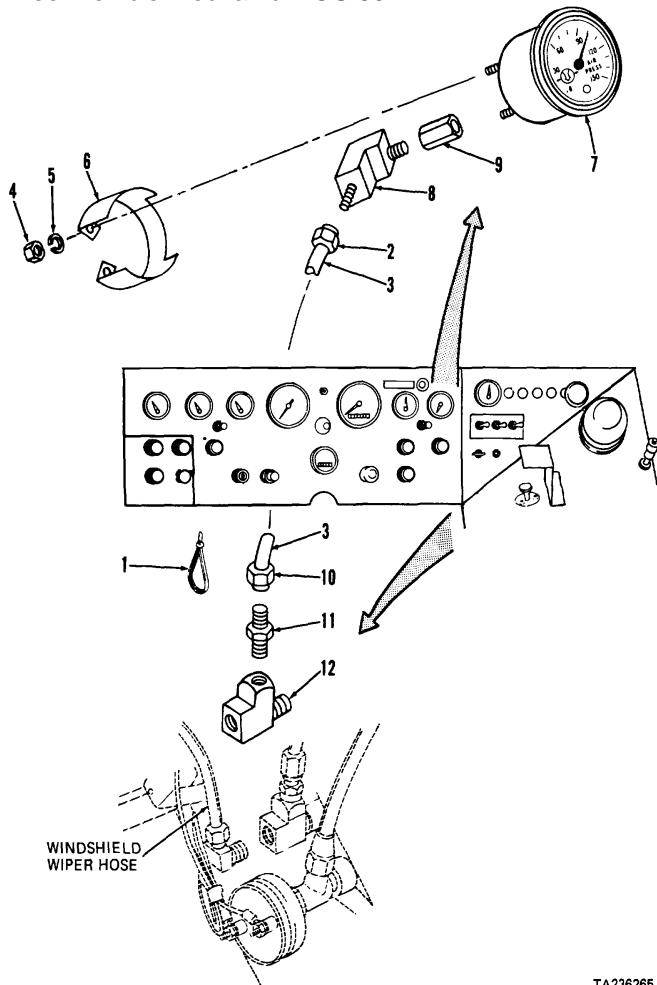

KEY

- 1. Nuts (2)
- 2. Lock washers (2)
- 3. Electrical lead (BLK)
- 4. Electrical lead (TAN/BLK)
- 5. Nuts (2)
- 6. Lock washers (2)
- 7. Mounting clamp
- 8. Oil pressure gage

TA236265

2-87. PRESSURE GAGES MAINTENANCE

a. OIL PRESSURE Gage (cont).

STEP	LOCATION	ITEM	ACTION	REMARKS
REMOVAL				
NOTE				
Tag and identify all electrical leads before disconnecting and removing.				
1	Instrument panel, underside	a. Two electrical leads (3 and 4)	Tag	
		b. Two nuts (1) and lock washers (2)	Remove	
		c. Two electrical leads (3 and 4)	Disconnect	
		d. Two nuts (5) and lock washers (6)	Remove	
		e. Mounting clamp (7)	Remove	
2	Instrument panel, top(8)	Oil pressure gage	Remove	Lift from instrument panel
CLEANING				
3		a. Oil pressure gage (8) and leads (3 and 4)	Clean	Wipe with clean, dry cloth

WARNING

Dry cleaning solvent (P-D-680), used to clean parts is toxic and flammable. Wear protective goggles and gloves and use only in a well ventilated area. Avoid contact with skin, eyes, and clothes and don't breathe vapors. Do not use near open flame or excessive heat and don't smoke when using it. Failure to do so could cause serious injury. If you become dizzy while using cleaning solvent, get fresh air and medical attention immediately. If contact with skin or clothes is made, flush with large amounts of water. If contact with eyes is made, wash eyes with water and seek medical aid immediately.

2-87. PRESSURE GAGES MAINTENANCE

a. OIL PRESSURE Gage (cont).

STEP	LOCATION	ITEM	ACTION	REMARKS
CLEANING (cont) 3 (cont)		b. All other parts	Clean	Use cleaning solvent P-D-680; dry with clean cloths
INSPECTION frayed,		a. (3 and 4)	Electrical leads	Inspect Replace if insulation cut, or cracked or if conductor corroded or broken
		b. Oil pressure gage (8)	Inspect	Replace if cracked, broken, or inoperative. If electrical contacts dirty or discolored, polish to brightness with fine sandpaper
		c. All other parts	Inspect	Replace if cracked, broken, or threads damaged
INSTALLATION				
5	Instrument panel, top	Oil pressure gage (8)	Position	
6	Instrument panel,(7) underside	a. Mounting clamp	Position	On oil pressure gage (8) mounting studs
		b. Two lock washers (6)	Install and tighten	
		c. Two electrical leads (3 and 4)	Connect as tagged	Lead (3) to IGN terminal; lead (4) to SENDER terminal
		d. Two lock washers (2) and nuts (1)	Install and tighten	
		e. Gage light socket with bulb	Install	Para 2-26d(1)
7	Cab	Instrument panel	Lower and secure	Para 2-26g(1)
8	Battery box	Battery ground cable	Connect	Para 2-34a

2-87. PRESSURE GAGES MAINTENANCE

b. AIR PRESSURE Gage.

- This task covers: a. Removal c. Inspection
 b. Cleaning d. Installation

INITIAL SETUP

Tools

No. 1 Common Organizational Maintenance
 Tool Kit
 Socket wrench set

Equipment Condition

Paragraph Condition Description
 Vehicle parked on level surface, engine off, and parking brake applied. All air pressure relieved. Battery ground cable disconnected. Instrument panel raised. Gage bulb and socket removed.

Materials/Parts

Cleaning solvent	Item 1, Appendix C	2-41h(1)
Clean cloths	Item 2, Appendix C	2-34a
Teflon tape	Item 43, Appendix C	2-26g(1)
Tie strap	FSCM 96906 PN MS3667-1-9	2-26d(1)

Personnel Required

Wheel Vehicle Mechanic MOS 63B

STEP	LOCATION	ITEM	ACTION	REMARKS
------	----------	------	--------	---------

REMOVAL

1	Instrument panel, underside	a. Tie strap (1)	Cut, remove, and discard	Note location for installation From elbow (8) From tubing (3) only if tubing is to be replaced
		b. Tubing nut (2)	Loosen	
		c. Tubing (3)	Disconnect	
		d. Tubing nut (2)	Remove	
		e. Two nuts (4) and lock washers (5)	Remove	
		f. Mounting clamp (6)	Remove	
2	Instrument panel, top	Air pressure gage (7)	Remove	Lift from instrument panel
3	Air pressure gage (7)	a. Elbow (8)	Remove	
		b. Connector (9)	Remove	
4	Cab wall	a. Windshield wiper hose 2-69b(1) and elbow	Disconnect	From elbow (12); para

2-87. PRESSURE GAGES MAINTENANCE

b. AIR PRESSURE Gage (cont).

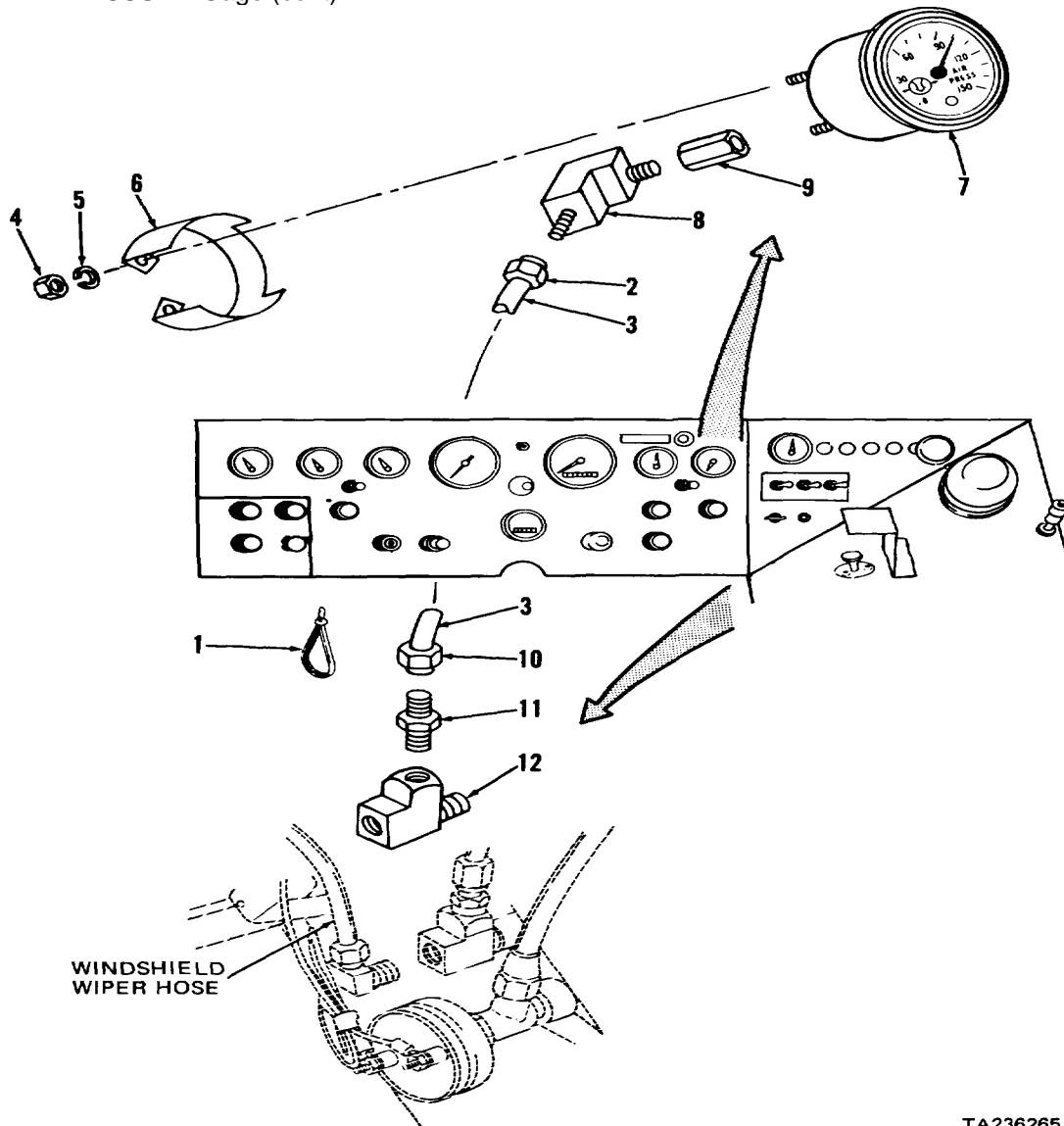

TA236265

KEY

- 1. Tie strap
- 2. Tubing nut
- 3. Tubing
- 4. Nuts (2)
- 5. Lock washers (2)
- 6. Mounting clamp
- 7. Air pressure gage
- 8. Elbow
- 9. Connector
- 10. Tubing nut
- 11. Connector
- 12. Tee

2-87. PRESSURE GAGES MAINTENANCE

b. AIR PRESSURE Gage (cont).

STEP	LOCATION	ITEM	ACTION	REMARKS
REMOVAL (cont)				
4 (cont)		b. Tubing nut (10)	Loosen	
		c. Tubing (3)	Disconnect	From connector (11)
		d. Tubing nut (10)	Remove	From tubing (3) only if tubing is to be replaced
		e. Tubing (3)	Remove	From tractor
		f. Connector (11)	Remove	From tee (12)
		g. Tee (12)	Remove	
CLEANING				
5		a. Tubing (3) and air pressure gage (7)	Clean	Wipe with clean, dry cloth

WARNING

Dry cleaning solvent (P-D-680), used to clean parts is toxic and flammable. Wear protective goggles and gloves and use only in a well ventilated area. Avoid contact with skin, eyes, and clothes and don't breathe vapors. Do not use near open flame or excessive heat and don't smoke when using it. Failure to do so could cause serious injury. If you become dizzy while using cleaning solvent, get fresh air and medical attention immediately.

If contact with skin or clothes is made, flush with large amounts of water. If contact with eyes is made, wash eyes with water and seek medical aid immediately.

		b. All other parts	Clean	Use cleaning solvent P-D-680; dry with clean cloths
INSPECTION				
6		a. Tubing (3)	Inspect	Replace if cut, cracked, or deteriorated
		b. Air pressure gage (7)	Inspect	Replace if cracked, broken, leaking, or inoperative
		c. All other parts	Inspect	Replace if cracked, broken, or threads damaged

2-87. PRESSURE GAGES MAINTENANCE

b. AIR PRESSURE Gage (cont).

STEP	LOCATION	ITEM	ACTION	REMARKS
INSTALLATION				
7	Cab wall	a. Tee (12) and connector (11)	a. Tape b. Install	Wrap threads with Teflon tape
		b. Tubing nut (10)	Position, if removed	On end of tubing (3)
		c. Tubing (3)	a. Route b. Connect	To connector (11)
		d. Tubing nut (10)	Tighten	
		e. Windshield wiper hose and elbow	Connect	To elbow (12); para 2-69b(1)
8	Air pressure gage (7)	a. Connector (9)	Install	Wrap threads on air pressure gage (7) with Teflon tape
		b. Elbow (8)	a. Tape b. Install	Wrap threads with Teflon tape On connector (9)
9	Instrument panel, top(7)	Air pressure gage	Position	
10	Instrument panel, underside	a. Mounting clamp (6)	Position	On air pressure gage (7) studs
		b. Two lock washers (5) and	Install and tighten	
		c. Tubing nut (2)	Position, if removed	On end of tubing (3)
		d. Tubing (3)	Connect	To elbow (8)
		e. Tubing nut (2)	Tighten	
		f. New tie strap (1)	Install	At location noted during removal
		g. Gage light socket with bulb	Install	Para 2-26d(1)
11	Cab	Instrument panel	Lower and secure	Para 2-26g(1)
12	Battery box	Battery ground cable	Connect	Para 2-34a
13	Tractor	Air pressure	Restore	Para 2-41h(1)

2-87. PRESSURE GAGES MAINTENANCE

c. FUEL Gage.

- This task covers:
- a. Removal
 - b. Cleaning
 - c. Inspection
 - d. Installation

INITIAL SETUP

Tools

No. 1 Common Organizational Maintenance

- Combination wrench set
- Socket wrench set
- Safety glasses

Materials/Parts

- Cleaning solvent Item 1, Appendix C
 - Clean cloths Item 2, Appendix C
 - Fine sandpaper Item 4, Appendix C
 - Tags Item 14, Appendix C
- from fuel gage.

Personnel Required

Wheel Vehicle Mechanic MOS 63B

Equipment Condition

Paragraph Condition Description

- 2-34a Vehicle parked on level surface, engine off, and parking brake applied. Battery ground cable disconnected.
- 2-26g(1) Instrument panel raised.
- 2-26d(1) Gage light socket with bulb removed.
- 2-26b(3) Electrical leads disconnected

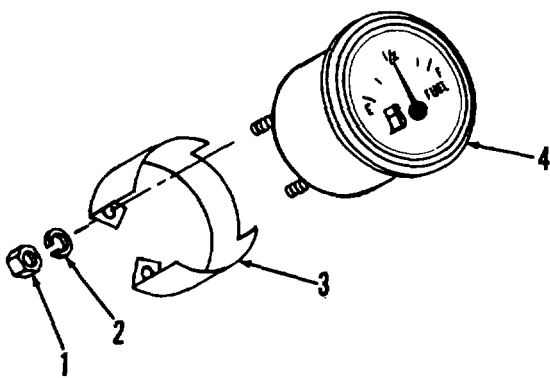

KEY

- 1. Nuts (2)
- 2. Lock washers (2)
- 3. Bracket
- 4. Fuel gage

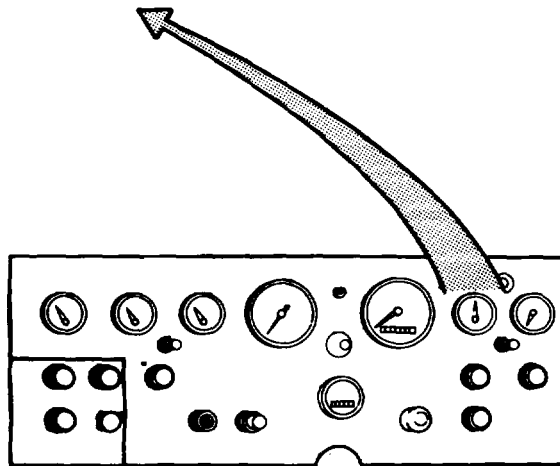

TA236295

2-87. PRESSURE GAGES MAINTENANCE

c. FUEL Gage (cont).

STEP	LOCATION	ITEM	ACTION	REMARKS
REMOVAL				
1	Instrument panel, underside	a. Two nuts (1) and lock washers (2) b. Bracket (3)	Remove	
2	Instrument panel, top	Fuel gage (4)	Remove	Lift from instrument panel

CLEANING

3		a. Fuel gage (4)	Clean	Wipe with clean, dry cloth
---	--	------------------	-------	----------------------------

WARNING

Dry cleaning solvent (P-D-680), used to clean parts is toxic and flammable. Wear protective goggles and gloves and use only in a well ventilated area. Avoid contact with skin, eyes, and clothes and don't breathe vapors. Do not use near open flame or excessive heat and don't smoke when using it. Failure to do so could cause serious injury. If you become dizzy while using cleaning solvent, get fresh air and medical attention immediately. If contact with skin or clothes is made, flush with large amounts of water. If contact with eyes is made, wash eyes with water and seek medical aid immediately.

		b. All other parts	Clean	Use cleaning solvent P-D-680; dry with clean cloths
--	--	--------------------	-------	---

INSPECTION

		a. Fuel gage (4)	Inspect	Replace if cracked, broken, or inoperative. If electrical contacts dirty or discolored, polish to brightness with fine sandpaper
electri-		b. All other parts	Inspect	Replace if cracked, broken, or threads damaged

2-87. PRESSURE GAGES MAINTENANCE

c. FUEL Gage (cont).

STEP	LOCATION	ITEM	ACTION	REMARKS
INSTALLATION				
5	Instrument panel, top	Fuel gage (4)	Position	
6	Instrument panel, underside	a. Bracket (3)	Position	On fuel gage (4) mounting studs
		b. Two lock washers (2) and	Install and tighten	
		c. Gage light socket with bulb	Install	Para 2-26d(1)
		d. Electrical leads	Connect	To FUEL gage; para 2-26b(3)
7	Cab	Instrument panel	Lower and secure	Para 2-26g(1)
8	Battery box	Battery ground cable	Connect	Para 2-34a

2-87. PRESSURE GAGES MAINTENANCE (CONT)

d. WATER TEMP Gage.

- This task covers:
- | | |
|-------------|-----------------|
| a. Removal | c. Inspection |
| b. Cleaning | d. Installation |

INITIAL SETUP

Tools

No. 1 Common Organizational Maintenance Tool Kit

- Socket wrench set
- Safety glasses

Materials/Parts

- | | |
|------------------|---------------------|
| Cleaning solvent | Item 1, Appendix C |
| Clean cloths | Item 2, Appendix C |
| Fine sandpaper | Item 4, Appendix C |
| Tags | Item 14, Appendix C |

Personnel Required

Wheel Vehicle Mechanic MOS 63BKEY

Equipment Condition

Paragraph Condition Description

- | | |
|----------|--|
| 2-34a | Vehicle parked on level surface, engine off, and parking brake applied. Battery ground cable disconnected. |
| 2-26g(1) | Instrument panel raised. |
| 2-26d(1) | Gage light socket with bulb removed. |

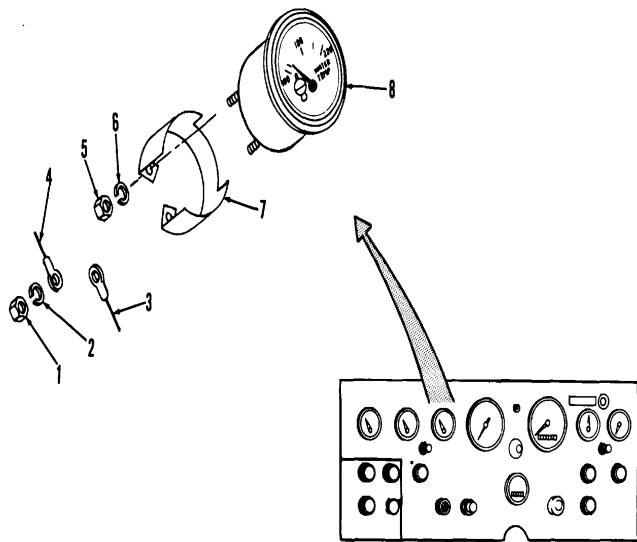

TA236264

KEY

1. Nuts (2)
2. Lock washers (2)
3. Electrical lead (BLK)
4. Electrical lead (GRN/BLK)
5. Nuts (2)
6. Lock washers (2)
7. Mounting clamp
8. Water temperature gage

2-87. PRESSURE GAGES MAINTENANCE (CONT)

d. WATER TEMP Gage (cont).

STEP	LOCATION	ITEM	ACTION	REMARKS
REMOVAL				
NOTE				
Tag and identify all electrical leads before disconnecting and removing.				
1	Instrument panel, underside	a. Two electrical leads (3 and 4)	Tag	
		b. Two nuts (1) and lock washers (2)	Remove	
		c. Two electrical leads (3 and 4)	Disconnect	
		d. Two nuts (5) and lock washers (6)	Remove	
		e. Mounting clamp (7)	Remove	
2	Instrument panel, top	Water temperature gage (8)	Remove	Lift from instrument panel
CLEANING				
3		a. Water temperature gage (8) and leads (3 and 4)	Clean	Wipe with clean, dry cloth

WARNING

Dry cleaning solvent (P-D-680), used to clean parts is toxic and flammable. Wear protective goggles and gloves and use only in a well ventilated area. Avoid contact with skin, eyes, and clothes and don't breathe vapors. Do not use near open flame or excessive heat and don't smoke when using it. Failure to do so could cause serious injury. If you become dizzy while using cleaning solvent, get fresh air and medical attention immediately. If contact with skin or clothes is made, flush with large amounts of water. If contact with eyes is made, wash eyes with water and seek medical aid immediately.

2-87. PRESSURE GAGES MAINTENANCE (CONT)

d. WATER TEMP Gage (cont).

STEP	LOCATION	ITEM	ACTION	REMARKS
CLEANING (cont)				
3 (cont)		b. All other parts	Clean	Use cleaning solvent P-D-680; dry with clean cloths
INSPECTION				
frayed,		a. (3 and 4)	Electrical leads	Inspect Replace if insulation cut, or cracked or if conductor corroded or broken
		b. Water temperature gage (8)	Inspect	Replace if cracked, broken, or inoperative. If electrical contacts dirty or discolored, polish to brightness with fine sandpaper
		c. All other parts or threads damaged	Inspect	Replace if cracked, broken,
INSTALLATION				
5	Instrument panel, top	Water temperature gage (8)	Position	
6	Instrument panel,(7) underside	a. Mounting clamp	Position	On water temperature gage (8) mounting studs
		b. Two lock washers (6)	Install and tighten	
		c. Two electrical leads (3 and 4)	Connect as tagged	Lead (3) to IGN terminal; lead (4) to SENDER terminal
		d. Two lock washers (2) and nuts (1)	Install and tighten	
		e. Gage light socket with bulb	Install	Para 2-26d(1)
7	Cab	Instrument panel	Lower and secure	Para 2-26g(1)
8	Battery box	Battery ground cable	Connect	Para 2-34a

2-88. HOURMETER MAINTENANCE

- This task covers:
- a. Removal
 - b. Cleaning
 - c. Inspection
 - d. Installation

INITIAL SETUP

Tools

No. 1 Common Organizational Maintenance

Socket wrench set
Safety glasses

Materials/Parts

Cleaning solvent	Item 1,	Appendix C
Clean cloths	Item 2,	Appendix C
Fine sandpaper	Item 4,	Appendix C
Tags	Item 14,	Appendix C

Personnel Required

Wheel Vehicle Mechanic MOS 63B

Equipment Condition

Paragraph	Condition Description
	Parked on level surface, engine off, and parking brake applied.
2-34a	Battery ground cable disconnected.
2-26g(1)	Instrument panel raised.

- KEY
- 1. Nut
 - 2. Lock washer
 - 3. Electrical lead (WHT)
 - 4. Nut
 - 5. Lock washer
 - 6. Clamp
 - 7. Electrical lead (WHT)
 - 8. Electrical lead (BLK)
 - 9. Hourmeter

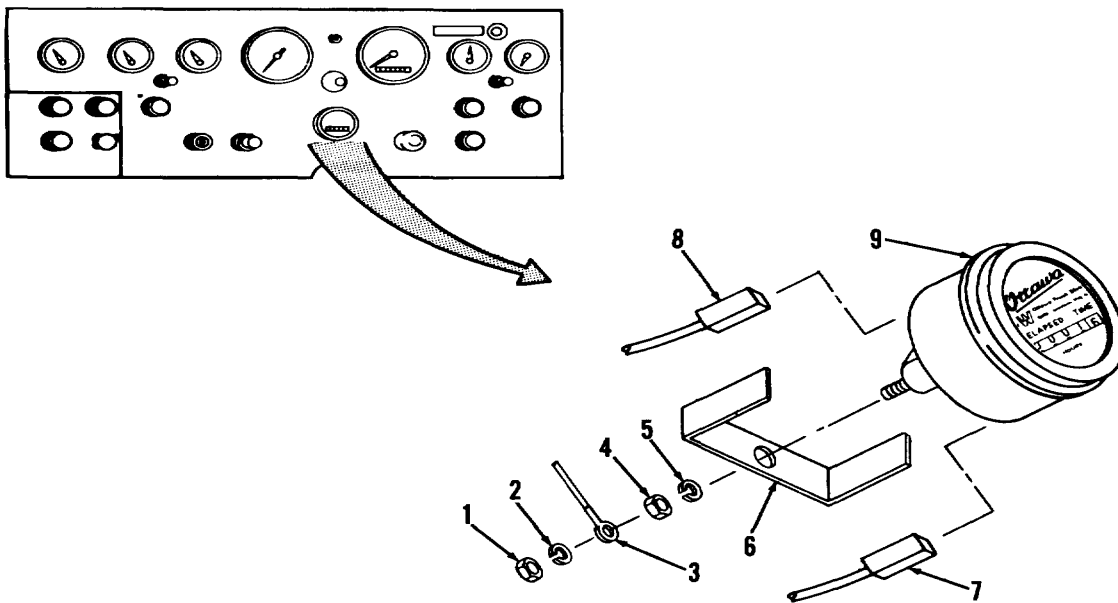

TA236266

2-88. HOURMETER MAINTENANCE (CONT)

STEP	LOCATION	ITEM	ACTION	REMARKS
REMOVAL				
NOTE				
Tag and identify all electrical leads before disconnecting and removing.				
1	Instrument panel, underside	a. Three electrical leads (3, 7, and 8)	Tag	
		b. Nut (1) and lock washer (2)	Remove	
		c. Electrical lead (3)	Disconnect	
		d. Nut (4) and lock washer (5)	Remove	
		e. Clamp (6)	Remove	
		f. Electrical leads (7 and 8)	Disconnect	Unplug from hourmeter (9) terminals
2	Instrument panel, top	Hourmeter (9)	Remove	Lift from instrument panel
CLEANING				
3	a.	Electrical leads (3, 7, and 8) and hourmeter (9)	Clean	Wipe with clean, dry cloth

WARNING

Dry cleaning solvent (P-D-680), used to clean parts is toxic and flammable. Wear protective goggles and gloves and use only in a well ventilated area. Avoid contact with skin, eyes, and clothes and don't breathe vapors. Do not use near open flame or excessive heat and don't smoke when using it. Failure to do so could cause serious injury. If you become dizzy while using cleaning solvent, get fresh air and medical attention immediately. If contact with skin or clothes is made, flush with large amounts of water. If contact with eyes is made, wash eyes with water and seek medical aid immediately.

2-88. HOURMETER MAINTENANCE (CONT)

STEP	LOCATION	ITEM	ACTION	REMARKS
CLEANING (cont)				
3 (cont)		b. All other parts	Clean	Use cleaning solvent P-D-680; dry with clean cloths
INSPECTION				
4		a. Electrical leads (3, 7, and 8)	Inspect	Replace if insulation frayed, cut, or cracked or if conductor corroded or broken
		b. Hourmeter (9)	a. Inspect	Replace if cracked, broken, or inoperative. If electrical terminals are dirty or corroded, polish to brightness with fine sandpaper
			b. Record reading	If hourmeter (9) is defective enter old and new hourmeter readings in vehicle logbook
		c. All other parts	Inspect	Replace if cracked, broken, or threads damaged
INSTALLATION				
5	Instrument panel, top	Hourmeter (9)	Position	In instrument panel
6	Instrument panel, underside	a. Electrical leads (7 and 8)	Connect	Plug into hourmeter (9) terminals as tagged
		b. Clamp (6)	Position	
		c. Nut (4) and lock washer (5)	Install and tighten	Secures clamp (6)
		d. Electrical lead (3)	Connect	
		e. Lock washer (2) and nut (1)	Install and tighten	Secures electrical lead (3)
7	Cab	Instrument panel	Lower and secure	Para 2-26g(1)
8	Battery box	Battery ground cable	Connect	Para 2-34a

Section XIII. PREPARATION FOR STORAGE OR SHIPMENT

This section contains the information you need to prepare the equipment for storage or shipment. It gives you information on preservation, packaging, packing, and administrative storage.

	Para		Para
Preservation and Packaging	2-89	Shipping	2-91
Packing	2-90	Administrative Storage	2-92

2-89. PRESERVATION AND PACKAGING

a. Cooling System. Check coolant level. If level is low, add clean solution of ethylene glycol antifreeze. Be sure cooling system contains antifreeze capable of providing protection as outlined below:

Lowest Estimated Temperature In Geographic Area	Antifreeze Mixture Percent By Volume
+20 to -30 degrees F	50% Ethylene Glycol & 50% Water
-30 to -55 degrees F	60% Ethylene Glycol & 40% Water

b. Lubrication System. Check lubricant level. If low, refer to current lubrication order and add lubricant. Operate engine until lubricant has been circulated through the system. Do not drain oil from crankcase.

c. Openings. Seal openings that will permit direct entry of water using pressure-sensitive tape conforming to PPP-T-60, type IV. Bridge large openings with water-proof barrier material conforming to PPP-B-1055, and secure edges of barrier material to adjacent surfaces using pressure-sensitive tape.

d. Fuel Tank. Draining of fuel tank is not required. If fuel tank is empty, no preservation is required.

e. Hydraulic Systems. Retract the cylinders as far as possible. Coat exposed portions of the hydraulic piston ram shafts with type P-6 preservative (CL) conforming to MIL-C-11796, class 3. Grease, automotive and artillery, conforming to MIL-G-10924 may be used if type P-6 preservative is unavailable. Wrap the coated shafts with type 1, class 2, grade A, grease proof barrier material conforming to MIL-B-121.

f. Air System. Open air reservoir drain cock to relieve all air system pressure.

g. Electrical System. Ensure that batteries are filled, fully charged, and secured in battery compartment. Disconnect cable terminals and secure to battery support with tape to prevent grounding. Secure battery box hasp with a padlock.

2-89. PRESERVATION AND PACKAGING (CONT)

h. Tires. Inflate tires to normal operating pressure of 120 psi. Secure spare tire to spare tire carrier using supplied chain and padlock.

i. Ignition Keys. Insert key into cab door lock and rotate 90 degrees clockwise to lock door. Remove, package, and place keys in the tool box to prevent pilferage. Secure tool box hasp with a padlock.

j. Exterior Surfaces. Coat exposed machined ferrous metal surfaces, such as fifth wheel plate, with type P-6 preservative (CL) conforming to MIL-C-11796, class 3. GAA grease may be substituted if type P-6 preservative is unavailable.

2-90. PACKING

Packing is not required unless components have been removed to prevent pilferage. Pack all removed components and the ignition keys in the tool box. If parts will not fit in the tool box, pack the parts in suitable containers and secure to tractor to prevent pilferage.

2-91. SHIPPING

a. Rail Shipment. Block and secure equipment to the railway car in accordance with the Association of American Railroads, "Rules Governing the Loading of Commodities on Open Top Cars. "

b. Highway Shipment. Load, block, and brace vehicle and equipment for haul-away or tow-away in accordance with the applicable motor carrier tariff.

c. Tractor Tie Downs. Use chock blocks at front and rear of tractor tires. Use cables, chains, or straps of sufficient capacity to tie tractor down as shown below:

2-939

2-91. SHIPPING (CONT)

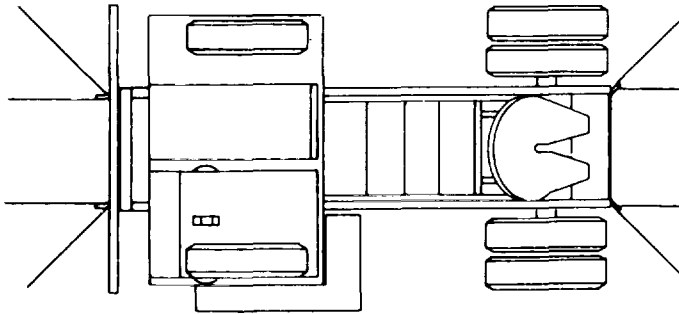

LIFTING AND TIEDOWN
ACTUAL WEIGHT - 15,500 POUNDS
LIFTING- Use cables, chains, or straps of sufficient capacity to lift unit as shown. Spreader bar should be used to prevent damage to cab and bumper guard.
TIE DOWN - Use cables, chains, or straps of sufficient capacity, and tie down as shown. Chock blocks should also be used as shown.

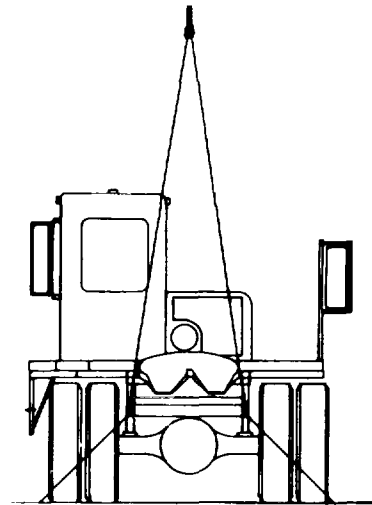
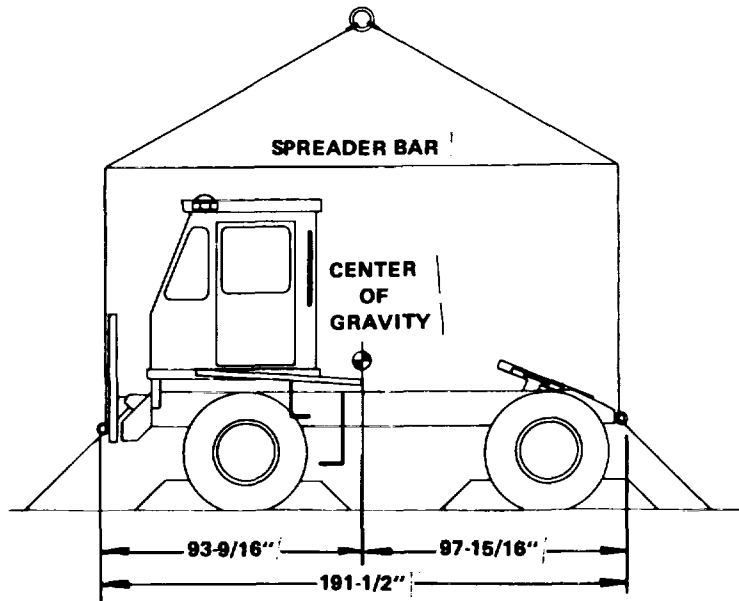

TA236183

2-92. ADMINISTRATIVE STORAGE

Refer to the following publications for administrative storage:

- | | |
|--------------|---|
| TB 740-97-2 | Preservation for Shipment and Storage (US Army) |
| TM 740-90-1 | Administrative Storage of Equipment |
| TM 743-200-1 | Storage of Material Handling Equipment |
| TM 743-200-2 | Storage Modernization |
| TM 743-200-3 | Storage MHE Equipment |

ALPHABETICAL INDEX

Subject	Para	Subject	Para
A		A (Cont)	
Accelerator and Throttle		Air Compressor (Cont)	
Linkage		principles of operation	1-23
adjustment	2-13e	servicing	2-52a
maintenance	2-13e	troubleshooting	
principles of operation	1-17	direct support	3-22
troubleshooting	2-8	organizational	2-48
Adapter Housing Assembly	4-4g	Air Control Valve	
Adjustment		maintenance	3-24a
accelerator and throttle	2-13e	troubleshooting	3-21
air horn	2-72	Air Horn	2-72
backup light switch	2-32e	AIR PRESS Gage	
defroster control	2-73b	maintenance	2-87b
fresh air control	2-73b	principles of operation	1-32
front axle brakes	2-50a	troubleshooting	2-83
fuel level sender	2-32b	Air Reservoirs	
gear shift control lever		maintenance	2-51b
and cable	2-41g(1)	principles of operation	1-23
governor, air compressor	2-52d	troubleshooting	2-47
heater temperature control	2-73b	Air Strainer	
hood and latch	2-65f	maintenance	2-52b
horn and relay	2-33a	principles of operation	1-23
hydraulic control valve,		servicing	2-52b
fifth wheel	3-42c	Alarmstat	
neutral start switch	2-32e	maintenance	2-32c
power steering gear	3-28d	troubleshooting	2-21
rear axle brakes air		Alcohol Evaporator	
chambers	2-51d(2)	maintenance	2-52c
speed shift, transmission	3-17b	principles of operation	1-23
tie rod	3-28c	servicing	2-52c
torque converter	4-3	Alternator	
windshield washer	2-69c	direct support	
Administrative Storage	2-92	maintenance	3-9
Air Brake Lines and Fittings		testing	3-9
maintenance	2-51a	troubleshooting	3-7
troubleshooting	2-47	organizational	
Air Cleaner Assembly		maintenance	2-24
maintenance	2-13a	testing	2-24
principles of operation	1-17	troubleshooting	2-17
servicing	2-13a	principles of operation	1-20
troubleshooting	2-8	Ammeter and 40A Circuit	
Air Compressor		Breaker	
assembly		maintenance	2-26e
direct support maintenance	3-25b	principles of operation	1-20a
organizational maintenance	2-52e	troubleshooting	2-19
governor		Arm Rest, Door	2-65i
adjustment	2-52d	Automatic Drain Valve	
direct support maintenance	3-25a	maintenance	3-24e
organizational maintenance	2-52d	troubleshooting	3-21

ALPHABETICAL INDEX - Continued

Subject	Para	Subject	Para
	A (Cont)		B (Cont)
Axle		Brake System (Cont)	
see Front Axle		direct support maintenance	
see Rear Axle		air compressor governor	3-25a
	B	air control valve	3-24a
Backup Light Switch		automatic drain valve	3-24e
adjustment	2-32e	double check valve	3-24d
maintenance	2-32e	quick release valve	3-24b
testing	2-32e	ratio reducing valve	3-24f
troubleshooting	1-20	relay valve	3-24g
Ball Sockets and Steering		tractor protection valve	3-24h
Linkage		trailer hand brake control	3-24c
maintenance	3-28e	treadle valve	3-23
troubleshooting	3-27	organizational maintenance	
Batteries		air brake lines	2-51a
charging	2-34a	air compressor assembly	2-52e
maintenance	2-34a	air compressor governor	2-52d
principles of operation	1-20	air reservoirs	2-51b
testing	2-34a	air strainer	2-52b
troubleshooting	2-23	alcohol evaporator	2-52c
Battery Box		front axle brakes	2-50a
maintenance	2-34b	front axle brakes air	
repair	2-34b	chambers	2-51d(1)
troubleshooting	2-23	hose tender	2-53b
Battery Cables		low air pressure switch	2-51c
maintenance	2-34a	rear axle brakes	2-50b
troubleshooting	2-23	rear axle brakes air	
Battery Warmers		chambers	2-51d(2)
maintenance	2-73c	trailer brake lines and	
troubleshooting	2-68	couplings	2-53a
Bell, Water Level Warning		troubleshooting	
see Water Level Warning Bell		air brake	2-47
Belt, Seat	2-651	brake controls	3-21
Bleed Valve, Fifth Wheel	2-78b(2)	service brake	2-46
Blower Switch		Brakes Maintenance	
maintenance	2-26a(8)	front axle	2-50a
principles of operation	1-20b	rear axle	2-50b
troubleshooting	2-68	Bumper	
Boom Platform and Latch		dock	2-65b
maintenance	2-63e	front	2-65e
troubleshooting	2-60	Buzzer, Low Air Pressure	
Boom, Fifth Wheel	3-33d	maintenance	2-26c(2)
Box, Tool		troubleshooting	2-19
see Tool Box			C
Brake System		Cab	
direct support maintenance		deck	3-35c
air compressor assembly	3-25b		

ALPHABETICAL INDEX - Continued

Subject	Para	Subject	Para
		C (Cont)	C (Cont)
Cab (Cont)		Cable, Modulator	
door maintenance		direct support maintenance	3-17e
direct support	3-35b	organizational maintenance	2-41i
organizational	2-65i	Cables	
floor mat	3-35e	see Battery Cables	
grille	2-65h	see Ground Straps	
guard, rear		see Starter Solenoid and 70 AMP Circuit Breaker	
see Rear Cab Guard		see Trailer Lighting Cables	
harnesses		Care, Safety, and Handling	1-14
see Wiring Harnesses		Center Support Assembly	4-4e
heater		Chassis Harnesses	
direct support maintenance	3-38	see Wiring Harnesses	
direct support trouble- shooting	3-37	Circuit Breakers and Fuse	2-35g
organizational maintenance	2-73a	Clutch	
organizational trouble- shooting	2-68	see Fan Drive Assembly	
principles of operation	1-29	see Transmission	
temperature valve mainte- nance	2-73a	Cold Start Aid	
interior light		see Quick Start	
maintenance	2-31c	Common Tools and Equipment	1-8
troubleshooting	2-20	Components, Major	1-12a
maintenance	3-35c	Control	
mounts	3-35a	see Defroster Control	
pivot pins and bushings	2-65k	see Fresh Air Control	
principles of operation	1-28	see Heater Temperature Control	
rear panel	3-35d	Control Cable	
troubleshooting		cab heater	2-73b
direct support	3-32	fifth wheel	2-78a
organizational	2-62	gear shift	2-41g(l)
Cab Tilt		Control Lever Maintenance	
direct support maintenance		fifth wheel	2-78a
hold down assembly	3-43d	gear shift	2-41g(l)
hydraulic cylinder	3-43b	Control Valve Assembly, Transmission	
hydraulic latches	3-43c	maintenance	4-4j
hydraulic pump	3-43a	principles of operation	1-21
90 degrees	3-35j	Control Valve Maintenance	
safety bar	3-43e	air	3-24a
organizational maintenance		trailer hand brake	3-24d
hydraulic pump	2-79a	Control Valve, Fifth Wheel	
lines and fittings	2-79b	maintenance	3-42c
troubleshooting		principles of operation	1-30
direct support	3-41	troubleshooting	2-76
organizational	2-77	Coolant Filter	
Cable, Control		principles of operation	1-19
see Control Cable		removal	2-15b(2)
		servicing	2-15b(1)

ALPHABETICAL INDEX - Continued

Subject	Para	Subject	Para
C (Cont)		D (Cont)	
Coolant Heater and Pump		Dock Bumpers	2-65b
maintenance	2-73e	Dome Light	
troubleshooting	2-68	see Cab interior light	
Coolant Pump		Door, Cab	
see Coolant Heater and Pump		direct support	
Coolant Recovery System	2-15f	maintenance	3-35b
Cooling System		troubleshooting	3-32
direct support maintenance		organizational	2-65i
fan drive assembly	3-5c	maintenance	2-65i
fan shroud	3-5b	troubleshooting	2-62
radiator	3-5a	Double Check Valve	
troubleshooting	3-3	maintenance	3-24d
organizational maintenance		troubleshooting	3-21
coolant recovery system	2-15f	Drain Valve, Automatic	
drive belts	2-15d	see Automatic Drain Valve	
fan	2-15d	Drive Assembly, Fan	
fan clutch control system	2-15e	see Fan Drive Assembly	
hoses	2-15c	Drive Axle	
troubleshooting	2-11	see Rear Axle	
Cylinder, Hydraulic		Drive Belts	
see Hydraulic Cylinder		air compressor	2-15d
Cylinder, Pneumatic		alternator	2-24
see Shift Lockout Cylinder		fan drive	2-15d
see Unlatch Cylinder		Drive Shaft	
		see Propeller Shaft	
D		Drum, Brake	
Dash Lights	2-26d(2)	see Hub and Drum	
Data and Instruction Plates	2-74		
Deck, Cab	3-35c	E	
Defroster Control		EIR, Reporting	1-5
adjustment	2-73b	Electrical System	
maintenance	2-73b	diagram	E-1
principles of operation	1-20b	direct support maintenance	
troubleshooting	2-68	alternator	3-9
Destruction of Army Materiel	1-3	front chassis wiring	
Diagrams	E-1	harness	3-12b(l)
Differential		front panel wiring harness	3-12c(1)
direct support maintenance	3-19b	lower cab wiring harness	3-12a(2)
general support maintenance	4-5	rear chassis wiring	
principles of operation	1-22	harness	3-12b(2)
troubleshooting	3-16	right corner panel wiring	
Dimmer Switch	2-26a(5)	harness	3-12c(2)
Diodes	2-35f	right panel wiring harness	3-12c(3)
Dipstick Tube		starter	3-10
engine	2-12e	upper cab wiring harness	3-12a(l)
transmission	2-41k	water level warning kit	3-11
Dismounting Tires	2-57		

ALPHABETICAL INDEX - Continued

Subject	Para	Subject	Para
E (Cont)		E (Cont)	
Electrical System (Cont)		Electrical System (Cont)	
organizational maintenance		right corner panel wiring	
alarmstat	2-32c	harness	2-35c(2)
alternator	2-24	right instrument panel	2-26g(3)
ammeter	2-26e	right panel wiring harness	2-35c(3)
backup light switch	2-32e	service brakes stop light	
batteries	2-34a	switch	2-32f(1)
battery box	2-34b	starter	2-25b
battery cables	2-34a	starter solenoid	2-25a
blower switch	2-26a(8)	tail and stop lights	2-31b
cab interior light	2-31c	trailer hand brake stop	
circuit breakers and fuse	2-35g	light switch	2-32f(2)
dash lights	2-26d(2)	trailer light switch	2-26a(7)
dimmer switch	2-26a(5)	trailer lighting cables	2-31f
diodes	2-35f	transmission temperature	
engine stop switch	2-26a(3)	sender	2-32d
engine warning kit	2-28	TRANS/TORQUE CONVERTER	
engine wiring harness	2-35d	light	2-26b(2)
flood lights	2-31g	turn signal control	2-27
flood light switches	2-26a(6)	turn signal flasher	2-26a(10)
front chassis wiring		24V inverter	2-30
harness	2-35b(1)	24V INVERTER light	2-26b(4)
front instrument panel	2-26g(1)	24V INVERTER switch	2-26a(9)
front panel wiring harness	2-35c(1)	upper cab wiring harness	2-35a(1)
front turn indicator light	2-31d	voltmeter	2-26f
fuel level sender	2-32b	water level warning bell	2-26c(1)
gage lights	2-26d(1)	water level warning kit	2-29
ground straps	2-35e	WATER LEVEL warning light	2-26b(4)
headlight switch	2-26a(4)	water temperature sender	2-32c
headlights	2-31a	WATER TEMP warning light	2-26b(4)
high beam indicator light	2-26b(1)	Engine	
horn and relay	2-33a	direct support	
horn switch	2-33b	maintenance	3-4
ignition switch	2-26a(1)	repair	3-4
LOW AIR warning light	2-26b(4)	troubleshooting	3-2
low air pressure buzzer	2-26c(2)	organizational	
lower cab wiring harness	2-35a(2)	repair	2-12b
LOW FUEL INDICATOR light	2-26b(3)	servicing	2-12a
marker lights	2-31e	troubleshooting	2-8
neutral start switch	2-32e	principles of operation	1-16
oil pressure sender	2-32a	Engine Oil Heater	
oil pressure sensor	2-32a	maintenance	2-73d
OIL PRESSURE warning light	2-26b(4)	troubleshooting	2-68
quick start switch	2-26a(2)	Engine Oil Sampling Valve	2-12f
rear chassis wiring		Engine Stop Switch	
harness	2-35b(2)	maintenance	2-26a(3)
right corner instrument		principles of operation	1-20b
panel	2-26g(2)	troubleshooting	2-19

ALPHABETICAL INDEX - Continued

Subject	Para	Subject	Para
	E (Cont)		F (Cont)
Engine Warning Kit	2-28	Fifth Wheel	
Engine Wiring Harness		direct support maintenance	3-33c
direct support maintenance	3-12d	boom	3-33d
organizational maintenance	2-35d	hydraulic control valve	3-42c
testing	2-35d	hydraulic cylinders	3-42d
Engine Oil Filter		hydraulic pump	3-42a
engine-mounted	2-12c	power take-off	3-42b
external	2-12d	unlatch cylinder	3-33a
Engine-Transmission Removal	3-4	unlatch valve	3-33b
Equipment		troubleshooting	3-30
see Truck Tractor, Yard Type		hydraulic system trouble-	
Equipment Improvement Recom-		shooting	
mendations, Reporting	1-5	direct support	3-40
Ether Starting Aid		organizational	2-76
see Quick Start		organizational maintenance	
Evaporator, Alcohol		control cable	2-78a
see Alcohol Evaporator		control lever	2-78a
Exhaust Pipes		hydraulic filters	2-78b(1)
maintenance	2-14a	hydraulic lines and	
principles of operation	1-18	fittings	2-78b(2)
troubleshooting	2-10	hydraulic reservoir	2-78c
Exhaust Stack		principles of operation	1-26
maintenance	2-14b	repair	3-33c
principles of operation	1-18	servicing	2-63d
troubleshooting	2-10	Filters	
Expendable Supplies and		air cleaner	2-13a
Materials List	C-1	air compressor governor	3-25a
External Oil Filter		air strainer	2-52b
engine	2-12d	alcohol evaporator	2-52c
transmission	2-41e	cab tilt pump screen	3-43a
		coolant	2-15b(l)
		engine oil	
	F	engine-mounted	2-12c
		external	2-12d
Fan Clutch Control System	2-15e	fan clutch control	2-15e
Fan Drive Assembly		fuel	2-13c
maintenance	3-5c	hydraulic, fifth wheel	2-78b(1)
principles of operation	1-19	power steering reservoir	2-58c
troubleshooting	2-11	transmission oil	
Fan Shroud		external	2-41e
maintenance	3-5b	governor	2-41d
principles of operation	1-19	sump	2-41c
repair	3-5b	unlatch cylinder	3-33a
Fan and Drive Belts		First Aid Kit	2-71c
maintenance	2-15d	First Clutch Assembly	4-4f
principles of operation	1-19	Fittings and Lines	
troubleshooting	2-11	see Lines and Fittings	
		Flaps, Mud	2-65b

ALPHABETICAL INDEX - Continued

Subject	Para	Subject	Para
F (Cont)		F (Cont)	
Flood Light Switches		Front Panel Wiring Harness	
maintenance	2-26a(6)	organizational maintenance	2-35c(1)
principles of operation	1-20b	testing	
troubleshooting	2-20	2-35c(1)	
Flood Lights		Front Support and Oil Pump	4-41
maintenance	2-31g	Front Turn Indicator Lights	
troubleshooting	2-20	maintenance	2-31d
Floor Hat	3-35e	troubleshooting	2-20
Forms		Fuel Filters	
see Maintenance Forms, Rec-		maintenance	2-13c
ords, and Reports		principles of operation	1-17
Forward Clutch and Shaft		servicing	2-13c
Assembly	4-4c	FUEL Gage	
Fourth Clutch Assembly	4-4d	maintenance	2-87c
Four-way Flasher		principles of operation	1-32
see Hazard Warning Switch		troubleshooting	2-83
Frame Grille	2-63a	Fuel Level Sender	
Fresh Air Control		adjustment	2-32b
adjustment	2-73b	maintenance	2-32b
maintenance	2-73b	troubleshooting	2-21
principles of operation	1-20b	Fuel Lines and Fittings	
troubleshooting	2-68	maintenance	2-13b(2)
Front Axle		troubleshooting	2-9
brakes		Fuel System	
adjustment	2-50a	accelerator and throttle	
maintenance	2-50a	linkage	2-13e
principles of operation	1-23	air cleaner assembly	2-13a
troubleshooting	2-46	filters	2-13c
brakes air chambers		tank	2-13b(1)
maintenance	2-15d(l)	lines and fittings	2-13b(2)
principles of operation	1-23	quick start	2-13d
repair	2-15d(1)	restriction indicator	2-13a
troubleshooting	2-47	troubleshooting	2-9
hub and drum	2-43b	Fuel Tank	
maintenance	3-18	maintenance	2-13b(1)
principles of operation	1-22	principles of operation	1-17
servicing	2-43a	repair	2-13b(1)
troubleshooting		servicing	2-13b(1)
direct support	3-15	Fuse	
organizational	2-39	circuit breakers and fuse	2-35g
Front Chassis Wiring Harness		24V inverter	2-30
direct support maintenance	3-12b(1)		
organizational maintenance	2-35b(1)	G	
testing	2-35b(1)	Gage	
Front Instrument Panel Maintenance	2-26g(1)	AIR PRESSURE	2-87b
Front Panel Wiring Harness		ammeter	2-26e
direct support maintenance	3-12c(1)	FUEL	2-87c
		hourmeter	2-88

ALPHABETICAL INDEX - Continued

Subject	Para	Subject	Para
H (Cont)		I (Cont)	
Hydraulic Control Valve, Fifth Wheel	3-42c	Indicators, Instrument Panel see Instrument Panel	
Hydraulic Cylinder cab tilt		Inside Mirror Maintenance	2-70b
maintenance	3-43b	Instruction and Data Plates	2-74
principles of operation	1-31	Instrument Panel	
troubleshooting	2-77	dash lights maintenance	2-26d(2)
fifth wheel		gages and gage lights	
maintenance	3-42d	see Gage	
principles of operation	1-30	harnesses	
troubleshooting	2-76	see Wiring Harnesses	
Hydraulic Filters, Fifth Wheel	2-78b(1)	indicator maintenance	
Hydraulic Latches, Cab Tilt		bell, water level warning	2-26c(1)
maintenance	3-43c	buzzer, low air pressure	2-26c(2)
principles of operation	1-31	high beam	2-26b(1)
troubleshooting	2-77	LOW AIR warning	2-26b(4)
Hydraulic Pump, Cab Tilt		LOW FUEL INDICATOR	2-26b(3)
direct support maintenance	3-43a	OIL PRESSURE warning	2-26b(4)
organizational maintenance	2-79a	TRANS/TORQUE CONVERTER	2-26b(2)
principles of operation	1-31	24V INVERTER	2-26b(4)
servicing	2-79a	WATER LEVEL warning	2-26b(4)
troubleshooting	2-77	WATER TEMP warning	2-26b(4)
Hydraulic Pump, Fifth Wheel		maintenance	
maintenance	3-42a	front panel	2-26g(1)
principles of operation	1-30	right corner panel	2-26g(2)
troubleshooting	2-76	right panel	2-26g(3)
Hydraulic Pump, Power Steering		switch maintenance	
see Power Steering Pump		blower	2-26a(8)
Hydraulic Reservoir, Fifth Wheel		dimmer	2-26a(5)
maintenance	2-78c	engine stop	2-26a(3)
principles of operation	1-30	flood light	2-26a(6)
servicing	2-78c	headlight	2-26a(4)
Hydraulic Steering Lines and Fittings		ignition	2-26a(1)
maintenance	2-58b	quick start	2-26a(2)
repair	2-58b	trailer light	2-26a(7)
troubleshooting	2-56	24V INVERTER	2-26a(9)
Hydraulic System, Fifth Wheel		troubleshooting	2-19
see Fifth Wheel		Interior Light, Cab	2-31c
		troubleshooting	2-20
		Inverter, 24V	
		see 24V INVERTER	
I		J	
Ignition Switch		Jaws, Fifth Wheel	
maintenance	2-26a(1)	see Unlatch, Fifth Wheel	
principles of operation	1-20b	Joint, Universal	
Indicator, Restriction		see Propeller Shaft	
see Restriction Indicator		see Universal	Joint, Steering

ALPHABETICAL INDEX - Continued

Subject	Para	Subject	Para
M (Cont)		O (Cont)	
Modulated Lockup Valve Assembly	4-4h	OIL PRESSURE Warning Light maintenance	2-26b(4)
Modulator and Cable direct support	3-17e	principles of operation	1-20a
organizational	2-41i	troubleshooting	2-19
Mounting Plate, Gear Shift Control	2-41g(2)	Oil Pump and Front Support	4-41
Mounting Tires	2-57	Oil Sampling Valve engine	2-12f
Mounds cab	3-35a	transmission	2-41j
transmission	3-17f	Operation, Principles of see Principles of Operation	
Mud Flaps	2-65b	Orientation	1-7
Muffler maintenance	2-14b	P	
principles of operation	1-18	Panel instrument	
troubleshooting	2-10	see Instrument Panel	
N		radiator access	2-65g
Neutral Start Switch adjustment	2-32e	rear cab	3-35d
maintenance	2-32e	Paper Compartment	2-65m
testing	2-32e	PARKING BRAKE Valve see Air Control Valve	
troubleshooting	1-20	Parts, Repair	1-10
O		Pedal accelerator	2-13e
Oil Filter cab tilt pump screen	3-43a	brake	3-23
engine		Pipes, Exhaust see Exhaust Pipes	
engine-mounted	2-12c	Pivot Pins and Bushings, Cab	2-651
external	2-12d	PMCS (Organizational)	2-4
hydraulic, fifth wheel	2-78b(l)	Pogo Stick see Hose Tender	
power steering reservoir	2-58c	Power Steering Gear adjustment	3-28d
transmission	2-41c	maintenance	3-28d
external	2-41e	principles of operation	1-25
governor	2-41d	testing	3-28d
sump	2-41c	troubleshooting	3-27
Oil Heater, Engine see Engine Oil Heater		Power Steering Pump maintenance	3-28f
OIL PRESS Gage maintenance	2-87a	principles of operation	1-25
principles of operation	1-32	troubleshooting	3-27
troubleshooting	2-83	Power Steering Reservoir maintenance	2-58c
Oil Pressure Sender and Sensor maintenance	2-32a	servicing	2-58c
troubleshooting	2-21	troubleshooting	2-56
		Power Take-off, Fifth Wheel maintenance	3-42b

ALPHABETICAL INDEX - Continued

Subject	Para	Subject	Para
P (Cont)		Q	
Power Take-off (Cont)		Quick Release Valve	
principles of operation	1-30	maintenance	3-24b
troubleshooting	3-40	troubleshooting	3-21
Preparation for Storage or Shipment	1-4	Quick Start	
Pressure Gage		maintenance	2-13d
see Gage		principles of operation	1-17
Preventive Maintenance Checks and Services	2-4	switch	
Principles of Operation		maintenance	2-26a(2)
accessories	1-29	principles of operation	1-20b
axles	1-22	troubleshooting	2-8
brakes	1-23		
cab and body	1-28	R	
cab tilt hydraulic system	1-31	Radiator	
cooling system	1-19	access panel maintenance	2-65g
electrical system	1-20	coolant recovery system	2-15f
engine	1-16	hoses	2-15c
exhaust system	1-18	maintenance	3-5a
fifth wheel hydraulic system	1-30	principles of operation	1-19
frame	1-26	servicing	2-15a(1)
fuel system	1-17	testing	2-15a(2)
gages	1-32	troubleshooting	2-11
propeller shaft	1-21	Ratio Reducing Valve	
shock absorbers	1-27	maintenance	3-24f
springs	1-27	troubleshooting	3-21
steering system	1-25	Rear Axle	
towing attachments	1-26	axle assembly maintenance	3-19a
transmission	1-21	axle shaft maintenance	2-44b
wheels	1-24	brakes	
yard tractor	1-15	maintenance	2-50b
Propeller Shaft		principles of operation	1-23
maintenance	2-42	repair	2-50b
principles of operation	1-21	troubleshooting	2-46
servicing	2-42	brakes air chambers	
troubleshooting	2-38	adjustment	2-51d(2)
Protection Valves, Tractor		maintenance	2-51d(2)
see Tractor Protection Valves		principles of operation	1-23
PTO		troubleshooting	2-47
see Power Take-off		differential maintenance	
Publications		direct support	3-19b
compartment, storage	2-65m	general support	4-5
references	A-1	hub and drum maintenance	2-44b
type of manual	1-1a	principles of operation	1-22
Pump, Hydraulic		servicing	2-44a
see Hydraulic Pump, Cab Tilt		troubleshooting	
see Hydraulic Pump, Fifth Wheel		direct support	3-16
		organizational	2-40

ALPHABETICAL INDEX - Continued

Subject	Para	Subject	Para
		R (Cont)	R (Cont)
Rear Cab		Repair (Cont)	
guard	2-65d	hydraulic steering lines and fittings	2-58b
panel	3-35d	rear axle brakes	2-50b
window	3-35g	rear cab guard	2-65d
Rear Chassis Wiring Harness		seat	2-651
direct support maintenance	3-12b(2)	shift lockout lines and fittings	2-41h(l)
organizational maintenance	2-35b(2)	spare tire mount	2-63c
testing	2-35b(2)	tire	2-57
Rear Cover Assembly, Transmission		transmission mount	3-17f
4-4k		unlatch valve, fifth wheel	3-33b
Rear Enclosure, Engine	2-65f	upper seat assembly	3-35i(1)
Rear End		Repair Parts	1-10
see Differential		Reporting Equipment Improvement Recommendations	1-5
Rear Platform	2-65c	Reports	
Rear Window	3-35g	see Maintenance Forms, Records, and Reports	
Rear Window Guard	2-65j	Reservoir	
Records		see Air Reservoirs	
see Maintenance Forms, Records, and Reports		see Hydraulic Reservoir, Fifth Wheel	
Recovery System, Coolant	2-15f	see Power Steering Reservoir	
Reducing Valve, Ratio		Restriction Indicator	
see Ratio Reducing Valve		maintenance	2-13a
References, Publications	A-1	principles of operation	1-17
Relay, Horn		servicing	2-13a
see Horn and Relay		troubleshooting	2-9
Relay Valve		Right Corner Instrument Panel	2-26g(2)
maintenance	3-24g	Right Corner Panel Wiring Harness	
troubleshooting	3-21	direct support maintenance	3-12c(2)
Release Valve, Quick		organizational maintenance	2-35c(2)
see Quick Release Valve		testing	2-35c(2)
Repair		Right Instrument Panel	2-26g(3)
battery box	2-34b	Right Panel Wiring Harness	
door, cab	3-35b	direct support maintenance	3-12c(3)
engine warning kit	2-28	organizational maintenance	2-35c(3)
engine, direct support maintenance	3-4	testing	2-35c(3)
engine, organizational maintenance	2-12b	Right Side Window	3-35g
external oil filter, engine	2-12d	Rod, Tie	
fan shroud	3-5b	see Tie Rod	
fifth wheel	3-33c		
fifth wheel boom	3-33d	S	
front axle brakes air chambers	2-51d(l)	Safety Bar, Cab Tilt	3-43e
fuel tank	2-13b(l)	Safety, Care, and Handling	1-14
hold down assembly, cab tilt	3-43d		
hydraulic cylinders, fifth wheel	3-42d		

ALPHABETICAL INDEX - Continued

Subject	Para	Subject	Para
S (Cont)		S (Cont)	
Sampling Valve, Oil		Shipment	
see Oil Sampling Valve		see Preparation for Storage	
Seat		or Shipment	
belt maintenance	2-651	Shock Absorbers	
maintenance	2-651	maintenance	2-64
suspension maintenance	3-35i(2)	principles of operation	1-27
troubleshooting		troubleshooting	2-61
direct support	3-32	Shroud, Fan	
organizational	2-62	see Fan Shroud	
upper assembly	3-35i(1)	Side Mirror	2-70a
Second Clutch Assembly	4-4e	Side Step	2-65a
Service Brakes Stop Light		Spare Tire Mount	
Switch		maintenance	2-63c
maintenance	2-32f(l)	principles of operation	1-26
troubleshooting	1-20	repair	2-63c
Servicing		troubleshooting	2-60
air cleaner	2-13a	Special Tools	1-9
air compressor	2-52a	Speed Shift Adjustment, Trans-	
air strainer	2-52b	mission	3-17b
alcohol evaporator	2-52c	Speedometer	
coolant filter	2-15b(1)	maintenance	2-85
engine	2-12a	principles of operation	1-32
external oil filter, engine	2-12d	troubleshooting	2-81
external oil filter, trans-		Spitter Valve	
mission	2-41e	see Automatic Drain Valve	
fan clutch control system	2-15e	Springs and Spring Seats	
fifth wheel	2-63d	maintenance	3-34
front axle	2-43a	principles of operation	1-27
fuel filters	2-13c	troubleshooting	3-31
fuel tank	2-13b(1)	Stack, Exhaust	
hydraulic filters, fifth		see Exhaust Stack	
wheel	2-78b(1)	Starter	
hydraulic pump, cab tilt	2-79a	direct support	
hydraulic reservoir	2-78c	maintenance	3-10
power steering reservoir	2-58c	troubleshooting	3-8
propeller shaft	2-42	organizational	
radiator	2-15a(l)	maintenance	2-25b
rear axle	2-44a	testing	2-25b
restriction indicator	2-13a	troubleshooting	2-18
transmission	2-41a	principles of operation	1-20
Shaft		solenoid and 70 AMP circuit	
main, transmission	4-4b	breaker	2-25a
propeller		Steering Column	
see Propeller Shaft		maintenance	3-28a
rear axle	2-44b	principles of operation	1-25
Shift Lockout		troubleshooting	3-27
cylinder and linkage	2-41h(2)	Steering Gear, Power	
lines and fittings	2-41h(l)	see Power Steering Gear	

ALPHABETICAL INDEX - Continued

Subject	Para	Subject	Para
S (Cont)		S (Cont)	
Steering Lines and Fittings		Switch Maintenance (Cont)	
see Hydraulic Steering Lines		cab interior light	2-31c
and Fittings		dimmer	2-26a(5)
Steering Linkage and Ball		engine stop	2-26a(3)
Sockets		flood light	2-26a(6)
maintenance	3-28e	hazard warning	2-27
troubleshooting	3-27	headlight	2-26a(4)
Steering Pump, Power		horn	2-33b
see Power Steering Pump		ignition	2-26a(1)
Steering System		low air pressure	2-51c
direct support maintenance		neutral start	2-32e
power steering gear	3-28d	quick start	2-26a(2)
power steering pump	3-28f	stop light	
steering column	3-28a	service brakes	2-32f(1)
steering linkage and ball		trailer hand brake	2-32f(2)
sockets	3-28e	trailer light	2-26a(7)
tie rod	3-28c	turn signal	2-27
universal joint	3-28b	24V inverter	2-26a(9)
organizational maintenance		windshield	
hydraulic steering lines		washer	2-69c
and fittings	2-58b	wiper	2-69b
power steering reservoir	2-58c		
steering wheel	2-58a	T	
troubleshooting		Tachometer	
direct support	3-27	maintenance	2-86
organizational	2-56	principles of operation	1-32
Steering Wheel		testing	2-86
maintenance	2-58a	troubleshooting	2-82
troubleshooting	2-56	Tail and Stop Lights	
Step, Side	2-65a	maintenance	2-31b
Stop Light Switch		troubleshooting	2-20
see Service Brakes Stop		Tank, Air	
Light Switch		see Air Reservoirs	
see Trailer Hand Brake Stop		Temperature Control, Heater	
Light Switch		see Heater Temperature	
Storage		Control	
administrative	2-92	Temperature Sender, Water	
see Preparation for Storage		see Water Temperature Sender	
or Shipment		Test, Measurement, and	
Strainer, Air		Diagnostic Equipment	1-9
see Air Strainer		Testing	
Sun Visor	2-71a	alternator	
Supplies and Materials List	C-1	direct support	3-9
Support Equipment	1-9	organizational	2-24
Suspension, Seat	3-35i(2)	backup light switch	2-32e
Switch Maintenance		batteries	2-34a
backup light	2-32e	circuit breakers and fuse	2-35g
blower	2-26a(8)		

ALPHABETICAL INDEX - Continued

Subject	Para	Subject	Para
		T (Cont)	
Testing (Cont)		Tool Box	
diodes	2-35f	maintenance	2-65n
engine warning kit	2-28	troubleshooting	2-62
fan clutch control system	2-15e	Tools	
junction box	2-73f	common	1-8
neutral start switch	2-32e	special	1-9
power steering gear	3-28d	Torque Converter	
radiator	2-15a(2)	adjustment	4-3
shift lockout cylinder and linkage	2-41h(2)	direct support maintenance	3-17d
shift lockout lines and fittings	2-41h(1)	general support maintenance	4-3
starting system		principles of operation	1-21
solenoid and 70 AMP circuit breaker	2-25a	Torque Limits	D-1
starter	2-25b	Tow Hooks	
tachometer	2-86	maintenance	2-63b
transmission		troubleshooting	2-60
hydraulic pressure test	3-17a(2)	Tow Shackles	
road test	3-17a(1)	maintenance	2-63b
stall test	3-17a(3)	troubleshooting	2-60
water level warning kit	2-29	Tractor	
wiring harnesses		see Truck Tractor, Yard Type	
engine harness	2-35d	Tractor Protection Valves	
front chassis harness	2-35b(1)	maintenance	3-24h
front panel harness	2-35c(1)	troubleshooting	3-21
lower cab harness	2-35a(2)	TRAILER AIR SUPPLY Valve	
rear chassis harness	2-35b(2)	see Air Control Valve	
right corner panel harness	2-35c(2)	Trailer Brake Lines and Couplings	
right panel harness	2-35c(3)	maintenance	2-53a
upper cab harness	2-35a(1)	troubleshooting	2-49
Third Clutch Assembly	4-4e	Trailer Hand Brake	
Throttle and Accelerator		control valve	
Linkage		maintenance	3-24c
see Accelerator and Throttle Linkage		troubleshooting	3-21
Tie Rod		stop light switch	
adjustment	3-28c	maintenance	2-32f(2)
maintenance	3-28c	troubleshooting	1-20
troubleshooting	3-27	Trailer Light Switch	
Tilt, Cab		maintenance	2-26a(7)
see Cab Tilt		principles of operation	1-20b
Tires and Wheels		Trailer Lighting Cables	
maintenance	2-57	maintenance	2-31f
principles of operation	1-24	troubleshooting	2-20
spare tire mount	2-63c	Transmission	
troubleshooting	2-55	direct support maintenance	
		hydraulic pressure test	3-17a(2)
		modulator assembly	3-17e
		mount	3-17f

ALPHABETICAL INDEX - Continued

Subject	Para	Subject	Para
		T (Cont)	
Transmission (Cont)		Transmission (Cont)	
replacement, detailed		shift lockout	
procedure	3-17c(2)	cylinder	2-41h(2)
replacement, summary		lines and fittings	2-41h(l)
procedure	3-17c(1)	linkage	2-41h(2)
road test	3-17a(1)	vent assembly	2-41f
speed shift adjustments	3-17b	principles of operation	1-21
stall test	3-17a(3)	road test	3-17a(l)
torque converter	3-17d	servicing	2-41a
general support maintenance		stall test	3-17a(3)
adapter housing assembly	4-4g	troubleshooting	
center support assembly	4-4e	direct support	3-14
control valve assembly	4-4j	organizational	2-37
first clutch assembly	4-4f	Transmission Mount	3-17f
forward clutch and shaft		Transmission Oil Sampling	
assembly	4-4c	Valve	2-41j
fourth clutch assembly	4-4d	Transmission Temperature	
gear unit assembly	4-4b	Sender	
governor assembly	4-4k	maintenance	2-32d
housing	4-4a	troubleshooting	1-20
low clutch assembly	4-4g	Transmission-Engine Removal	3-4
low planetary assembly	4-4g	TRANS/TORQUE CONVERTER Light	
low shift valve assembly	4-4i	maintenance	2-26b(2)
main shaft	4-4b	principles of operation	1-20a
modulated lockup valve		Treadle Valve	
assembly	4-4h	maintenance	3-23
oil pump and front support	4-41	troubleshooting	3-21
rear cover assembly	4-4k	Troubleshooting	
second clutch assembly	4-4e	direct support	
third clutch assembly	4-4e	air compressor	3-22
torque converter	4-3	alternator	3-7
hydraulic pressure test	3-17a(2)	body and cab	3-32
organizational maintenance		brake controls	3-21
dipstick tube	2-41k	cab tilt hydraulic system	3-41
draining transmission		cooling system	3-3
fluid	2-41b	engine	3-2
external oil filter	2-41e	fifth wheel	3-30
gear shift control		fifth wheel hydraulic	
cable	2-41g(1)	system	3-40
lever	2-41g(1)	front axle	3-15
mounting plate	2-41g(2)	heater	3-37
governor oil filter	2-41d	rear axle	3-16
modulator cable	2-41i	springs and spring seats	3-31
oil filter	2-41c	starter	3-8
oil sampling valve	2-41j	steering system	3-27
refilling transmission		transmission	3-14
fluid	2-41b	treadle valve	3-21
servicing	2-41a	logic tree	E-5

ALPHABETICAL INDEX - Continued

Subject	Para	Subject	Para
		T (Cont)	
Troubleshooting (Cont)		Troubleshooting (Cont)	
organizational		hydraulic systems	3-39
air brake system	2-47	power train	3-13
air compressor	2-48	springs	3-29
battery system	2-23	steering system	3-26
body and cab	2-62	towing attachments	3-29
cab tilt hydraulic system	2-77	symptom index, organiza-	
charging system	2-17	tional	
cooling system	2-11	accessories	2-66
engine	2-8	body and cab	2-59
exhaust system	2-10	brake system	2-45
fifth wheel hydraulic		cooling system	2-7
system	2-76	electrical system	2-16
frame and towing attach-		engine	2-7
ments	2-60	exhaust system	2-7
front axle	2-39	frame	2-59
fuel system	2-9	fuel system	2-7
heaters	2-68	gages	2-80
horn system	2-22	hydraulic systems	2-75
hourmeter	2-84	power train	2-36
instrument panel	2-19	shock absorbers	2-59
light systems	2-20	steering system	2-54
pressure gages	2-83	towing attachments	2-59
propeller shaft	2-38	wheels	2-54
rear axle	2-40	Truck Tractor, Yard Type	
sending units	2-21	capabilities	1-11
service brake system	2-46	characteristics	1-11
shock absorbers	2-61	data	1-13
speedometer	2-81	equipment name	1-lb
starting system	2-18	features	1-11
steering system	2-56	model number	1-lb
tachometer	2-82	packaging	2-89
trailer brake lines and		packing	2-90
couplings	2-49	preliminary inspection	2-la
transmission	2-37	preliminary servicing	2-2
wheels and tires	2-55	preservation	2-89
windshield wiper and		principles of operation	1-15
washer	2-69	purpose	1-lc
symptom index	2-6	shipping	2-91
symptom index, direct sup-		unloading	2-lb
port		unpacked	
accessories	3-36	checking	2-id
body and cab	3-29	deprocessing	2-le
brake system	3-20	unpacking	2-lc
cooling system	3-1	Turn Signal	
electrical system	3-6	control	2-27
engine	3-1	flasher	2-26a(10)
frame	3-29	front light	2-31d

ALPHABETICAL INDEX - Continued

Subject	Para	Subject	Para
		W (Cont)	
WATER LEVEL Warning Light		Winterization System	
maintenance	2-26b(4)	battery warmers	2-73c
principles of operation	1-20a	coolant heater and pump	2-73e
troubleshooting	2-19	engine oil heater	2-73d
Water Temperature Sender		junction box	2-73f
maintenance	2-32c	troubleshooting	2-68
troubleshooting	2-21	Wiper, Windshield	
WATER TEMP Gage		see Windshield Wiper	
maintenance	2-87d	Wiring Harnesses	
principles of operation	1-32	direct support maintenance	
troubleshooting	2-83	engine harness	3-12d
WATER TEMP Warning Light		front chassis harness	3-12b(1)
maintenance	2-26b(4)	front panel harness	3-12c(1)
principles of operation	1-20a	lower cab harness	3-12a(2)
troubleshooting	2-19	rear chassis harness	3-12b(2)
Wheel, Steering		right corner panel harness	3-12c(2)
see Steering Wheel		right panel harness	3-12c(3)
Wheels and Tires		upper cab harness	3-12a(1)
see Tires and Wheels		organizational maintenance	
Window		engine harness	2-35d
door	3-35b	front chassis harness	2-35b(1)
rear	3-35g	front panel harness	2-35c(1)
right side	3-35g	lower cab harness	2-35a(2)
vent	3-35h	rear chassis harness	2-35b(2)
Windshield	3-35f	right corner panel harness	2-35c(2)
Windshield Washer		right panel harness	2-35c(3)
adjustment	2-69c	upper cab harness	2-35a(1)
maintenance	2-69c	principles of operation	1-20
principles of operation	1-29		
switch		Y	
maintenance	2-69c	Yard Tractor	
principles of operation	1-20b	see Truck Tractor, Yard Type	
troubleshooting	2-67		
Windshield Wiper			
arm	2-69a		
blade	2-69a		
motor	2-69b(2)		
principles of operation	1-29		
switch			
maintenance	2-69b(1)		
principles of operation	1-20b		
troubleshooting	2-67		

By Order of the Secretary of the Army:

JOHN A. WICKHAM, JR.
General, United States Army
Chief of Staff

Official:

DONALD J. DELANDRO
Brigadier General, United States Army
The Adjutant General

Distribution:

To be distributed in accordance with DA Form 12-25 A-R, Organizational, Direct Support, and General Support Maintenance Manual Requirements for Truck, Tractor, Yard Type, 4X2, M878 (w/5th wheel).

☆ U. S GOVERNMENT PRINTING OFFICE 1985-554-019/20175

THE METRIC SYSTEM AND EQUIVALENTS

LINEAR MEASURE

- 1 Centimeter = 10 Millimeters = 0.01 Meters = 0.3937 Inches
- 1 Meter = 100 Centimeters = 1,000 Millimeters = 39.37 Inches
- 1 Kilometer = 1,000 Meters = 0.621 Miles

SQUARE MEASURE

- 1 Sq Centimeter = 100 Sq Millimeters = 0.155 Sq Inches
- 1 Sq Meter = 10,000 Sq Centimeters = 10.76 Sq Feet
- 1 Sq Kilometer = 1,000,000 Sq Meters = 0.386 Sq Miles

CUBIC MEASURE

- 1 Cu Centimeter = 1,000 Cu Millimeters = 0.06 Cu Inches
- 1 Cu Meter = 1,000,000 Cu Centimeters = 35.31 Cu Feet

LIQUID MEASURE

- 1 Milliliter = 0.001 Liters = 0.0338 Fluid Ounces
- 1 Liter = 1,000 Milliliters = 33.82 Fluid Ounces

TEMPERATURE

- $5/9 (^{\circ}\text{F} - 32) = ^{\circ}\text{C}$
- 212° Fahrenheit is equivalent to 100° Celsius
- 90° Fahrenheit is equivalent to 32.2° Celsius
- 32° Fahrenheit is equivalent to 0° Celsius
- $9/5 \text{ C}^{\circ} + 32 = \text{F}^{\circ}$

WEIGHTS

- 1 Gram = 0.001 Kilograms = 1,000 Milligrams = 0.035 Ounces
- 1 Kilogram = 1,000 Grams = 2.2 lb.
- 1 Metric Ton = 1,000 Kilograms = 1 Megagram = 1.1 Short Tons

APPROXIMATE CONVERSION FACTORS

TO CHANGE	TO	MULTIPLY BY
Inches	Centimeters	2.540
Feet	Meters	0.305
Yards	Meters	0.914
Miles	Kilometers	1.609
Square Inches	Square Centimeters	6.451
Square Feet	Square Meters	0.093
Square Yards	Square Meters	0.836
Square Miles	Square Kilometers	2.590
Acres	Square Hectometers	0.405
Cubic Feet	Cubic Meters	0.028
Cubic Yards	Cubic Meters	0.765
Fluid Ounces	Milliliters	29.573
Pints	Liters	0.473
Quarts	Liters	0.946
Gallons	Liters	3.785
Ounces	Grams	28.349
Pounds	Kilograms	0.454
Short Tons	Metric Tons	0.907
Pound-Feet	Newton-Meters	1.356
Pounds Per Square Inch	Kilopascals	6.895
Miles Per Gallon	Kilometers Per Liter	0.425
Miles Per Hour	Kilometers Per Hour	1.609
TO CHANGE	TO	MULTIPLY BY
Centimeters	Inches	0.394
Meters	Feet	3.280
Meters	Yards	1.094
Kilometers	Miles	0.621
Square Centimeters	Square Inches	0.155
Square Meters	Square Feet	10.764
Square Meters	Square Yards	1.196
Square Kilometers	Square Miles	0.386
Square Hectometers	Acres	2.471
Cubic Meters	Cubic Feet	35.315
Cubic Meters	Cubic Yards	1.308
Milliliters	Fluid Ounces	0.034
Liters	Pints	2.113
Liters	Quarts	1.057
Liters	Gallons	0.264
Grams	Ounces	0.035
Kilograms	Pounds	2.205
Metric Tons	Short Tons	1.102
Newton-Meters	Pound-Feet	0.738
Kilopascals	Pounds Per Square Inch	0.145
Kilometers Per Liter	Miles Per Gallon	2.354
Kilometers Per Hour	Miles Per Hour	0.621

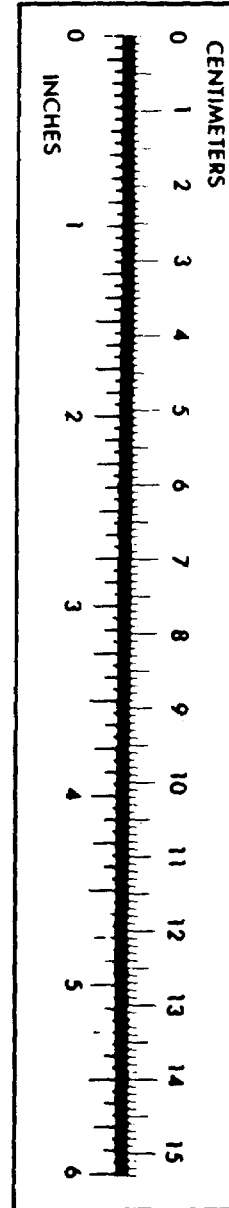

RECOMMENDED CHANGES TO EQUIPMENT TECHNICAL PUBLICATIONS



THEN... JOT DOWN THE DOPE ABOUT IT ON THIS FORM, CAREFULLY TEAR IT OUT, FOLD IT AND DROP IT IN THE MAIL!

SOMETHING WRONG WITH THIS PUBLICATION?

FROM: (PRINT YOUR UNIT'S COMPLETE ADDRESS)

DATE SENT

PUBLICATION NUMBER

TM 11-5825-270-10

PUBLICATION DATE

23 Jul 81

PUBLICATION TITLE

Radio Frequency R-2176/FRN

BE EXACT... PIN-POINT WHERE IT IS

PAGE NO.

PARA-GRAPH

FIGURE NO.

TABLE NO.

IN THIS SPACE TELL WHAT IS WRONG AND WHAT SHOULD BE DONE ABOUT IT:

TEAR ALONG PERFORATED LINE

PRINTED NAME, GRADE OR TITLE, AND TELEPHONE NUMBER

SIGN HERE:

DA FORM 2028-2 JUL 79

PREVIOUS EDITIONS ARE OBSOLETE.

P.S.—IF YOUR OUTFIT WANTS TO KNOW ABOUT YOUR RECOMMENDATION MAKE A CARBON COPY OF THIS AND GIVE IT TO YOUR HEADQUARTERS.

